

---

# User's Guide

---

Agilent 83480A Analyzer,

Agilent 54750A Oscilloscope

Agilent Part No. 83480-90050  
Printed in USA June 2000

Agilent Technologies  
Lightwave Division  
1400 Fountaingrove Parkway  
Santa Rosa, CA  
95403-1799, USA  
(707) 577-1400

HP and Hewlett-Packard are U.S. registered trademarks of Hewlett-Packard Company.

**Notice.** The information contained in this document is subject to change without notice. Agilent Technologies makes no warranty of any kind with regard to this material, including but not limited to, the implied warranties of merchantability and fitness for a particular purpose. Agilent Technologies shall not be liable for errors contained herein or for incidental or consequential damages in connection with the furnishing, performance, or use of this material.

**Restricted Rights Legend.** Use, duplication, or disclosure by the U.S. Government is subject to restrictions as set forth in subparagraph (c) (1) (ii) of the Rights in Technical Data and Computer Software clause at DFARS 252.227-7013 for DOD agencies, and subparagraphs (c) (1) and (c) (2) of the Commercial Computer Software Restricted Rights clause at FAR 52.227-19 for other agencies.

**Regulatory Information.** The front matter of this book contains regulatory information.

©Copyright Agilent Technologies 2000  
All Rights Reserved. Reproduction, adaptation, or translation without prior written permission is prohibited, except as allowed under the copyright laws.

---

## Safety Symbols

The following safety symbols are used throughout this manual. Familiarize yourself with each of the symbols and its meaning before operating this instrument.

---

### CAUTION

---

The *caution* sign denotes a hazard to the instrument. It calls attention to a procedure which, if not correctly performed or adhered to, could result in damage to or destruction of the instrument. Do not proceed beyond a *caution* sign until the indicated conditions are fully understood and met.

---

### WARNING

---

The *warning* sign denotes a life-threatening hazard. It calls attention to a procedure which, if not correctly performed or adhered to, could result in injury or loss of life. Do not proceed beyond a *warning* sign until the indicated conditions are fully understood and met.

---

### Instruction Manual



The **instruction manual** symbol. The product is marked with this symbol when it is necessary for the user to refer to the instructions in the manual.

---

### CE

The **CE** mark is a registered trademark of the European Community [if accompanied by a year, it's when the design was proven].

---

### ISM 1-A

This is a symbol of an Industrial Scientific and Medical Group 1 Class A product.



The CSA mark is a registered trademark of the Canadian Standards Association.



The line power on symbol.



The line power off symbol.

---

---

## General Safety Considerations

---

**WARNING**

*Before this instrument is switched on*, make sure it has been properly grounded through the protective conductor of the ac power cable to a socket outlet provided with protective earth contact.

Any interruption of the protective (grounding) conductor, inside or outside the instrument, or disconnection of the protective earth terminal can result in personal injury.

---

**WARNING**

There are many points in the instrument which can, if contacted, cause personal injury. Be extremely careful.

Any adjustments or service procedures that require operation of the instrument with protective covers removed should be performed only by trained service personnel.

---

**WARNING**

If this instrument is not used as specified, the protection provided by the equipment could be impaired. This instrument must be used in a normal condition (in which all means for protection are intact) only.

---

**WARNING**

For continued protection against fire hazard, replace line fuse only with same type and ratings (type nA/nV). The use of other fuses or materials is prohibited.

---

**WARNING**

The power cord is connected to internal capacitors that may remain live for 5 seconds after disconnecting the plug from its power supply.

---

**CAUTION**

*Before this instrument is switched on*, make sure its primary power circuitry has been adapted to the voltage of the ac power source.

Failure to set the ac power input to the correct voltage could cause damage to the instrument when the ac power cable is plugged in.

---

**CAUTION**

This is a Safety Class 1 Product (provided with a protective earthing ground incorporated in the power cord). The mains plug shall only be inserted in a socket outlet provided with a protective earth contact. Any interruption of the protective conductor inside or outside of the instrument is likely to make the instrument dangerous. Intentional interruption is prohibited.

---

**CAUTION**

---

Always use the three-prong ac power cord supplied with this instrument. Failure to ensure adequate earth grounding by not using this cord may cause instrument damage.

---

**CAUTION**

---

This instrument is designed for use in INSTALLATION CATEGORY II and POLLUTION DEGREE 2 per IEC 1010 and 664 respectively.

---

**CAUTION**

---

Ventilation requirements: When installing the instrument in a cabinet, the convection into and out of the instrument must not be restricted. The ambient temperature (outside the cabinet) must be less than the maximum operating temperature of the instrument by 4°C for every 100 watts dissipated in the cabinet. If the total power dissipated in the cabinet is greater than 800 watts, then forced convection must be used.

---

**CAUTION**

---

The input circuits can be damaged by electrostatic discharge (ESD). Repair of damage due to misuse is *not* covered under warranty. Therefore, avoid applying static discharges to the front-panel input connectors. Before connecting any coaxial cable to the connectors, momentarily short the center and outer conductors of the cable together. Avoid touching the front-panel input connectors without first touching the frame of the instrument. Be sure the instrument is properly earth-grounded to prevent buildup of static charge.

---

The electrical ports of plug-in modules, used with the Agilent 83480A and Agilent 54750A, are very sensitive to electrostatic discharge.

**NOTE**

This instrument has been designed and tested in accordance with IEC Publication 1010.1, and has been supplied in a safe condition. The instruction documentation contains information and warnings which must be followed by the user to ensure safe operation and to maintain the instrument in a safe condition.

**NOTE**

Clean the cabinet using a damp cloth only.

---

## Certification

Agilent Technologies certifies that this product met its published specifications at the time of shipment from the factory. Agilent Technologies further certifies that its calibration measurements are traceable to the United States National Institute of Standards and Technology, to the extent allowed by the Institute's calibration facility, and to the calibration facilities of other International Standards Organization members.

---

# X-Ray Radiation Notice

## X-RAY RADIATION NOTICE

ACHTUNG

Model HP 54750A/83480A

WARNING

Während des Betriebs erzeugt dieses Gerät Röntgenstrahlung. Das Gerät ist so abgeschirmt, daß die Dosisleistung weniger als 36  $\mu\text{A}/\text{kg}$  (0,5 mR/h) in 5cm Abstand von der Oberfläche der Kathodenstrahlröhre beträgt. Somit sind die Sicherheitsbestimmungen verschiedener Länder, u.A. der deutschen Röntgenverordnung eingehalten.

Die Stärke der Röntgenstrahlung hängt im wesentlichen von der Bauart der Kathodenstrahlröhre ab sowie von den Spannungen, welche an dieser anliegen. Um einen sicheren Betrieb zu gewährleisten, dürfen die Einstellungen des Niederspannungs- und Hochspannungsnetzteils nur nach der Anleitung in Kapitel Einstellvorschriften des Service Handbuchs vorgenommen werden.

Die Kathodenstrahlröhre darf nur durch die gleiche Type ersetzt werden. (Siehe Kapitel Ersatzteile für HP-Teilenummern.)

Das Gerät ist in Deutschland zugelassen unter der Nummer: BW/218/86/ROE

When operating, this instrument emits x-rays; however, it is well shielded and meets safety and health requirements of various countries, such as the X-ray Radiation Act of Germany.

Radiation emitted by this instrument is less than 0.5 mR/hr at a distance of five (5) centimeters from the surface of the cathode-ray tube. The x-ray radiation primarily depends on the characteristics of the cathode-ray tube and its associated low-voltage and high-voltage circuitry. To ensure safe operation of the instrument, adjust both the low-voltage and high-voltage power supplies as outlined in the Adjustments Section of the Service Manual.

Replace the cathode-ray tube with an identical CRT only. Refer to the Replacement Parts Section for the proper HP part number.

Number of German License: BW/218/86/ROE

X-RAY

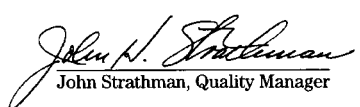

# Declaration of Conformity

<b>DECLARATION OF CONFORMITY</b>	
according to ISO/IEC Guide 22 and EN 45014	
<b>Manufacturer's Name:</b>	Hewlett-Packard Company
<b>Manufacturer's Address:</b>	1900 Garden of the Gods Road Colorado Springs , CO 80907 U.S.A.
<b>Declares, That the product</b>	
<b>Product Name:</b>	HP 83480A Analyzer, HP 54750A Oscilloscope
<b>Model Number(s):</b>	HP 83480A and HP 54750A
<b>Product Options:</b>	All
<b>Conforms to the following Product Specifications:</b>	
<b>Safety:</b>	IEC 1010-1:1990+A1 / EN 61010-1:1993 UL 1301 CSA - C22.2 No. 1010.1:1993
<b>EMC:</b>	CISPR 11:1990 /EN 55011 1991: Group 1 Class A IEC 801-2:1991 /EN 50082-1 1992: 4 kV CD, 8 kV AD IEC 801-3:1984 /EN 50082-1 1992: 3 V/m, {1kHz 80% AM, 27-1000 MHz} IEC 801-4:1988 /EN 50082-1 1992: 0.5 kV Sig Lines, 1 kV Power Lines
<b>Supplementary Information:</b>	
The product herewith complies with the requirements of the Low Voltage Directive 73/23/EEC and the EMC Directive 89/336/EEC.	
Colorado Springs, 9/15/94	 John Strathman, Quality Manager
European Contact: Your local Hewlett-Packard Sales and Service Office or Hewlett-Packard GmbH, Department ZQ / Standards Europe, Herrenberger Strasse 130, 71034 Böblingen Germany (FAX: +49-7031-143143)	

**Additional Information**

The following table lists additional performance information for the EMC product specifications listed in the *Declaration of Conformity*.

<b>EMC Product Specification</b>	<b>Performance Code</b>
IEC 801-2:1991 /EN 50082-1  1992 : 4kV CD, 8kV AD	PASS - Temporary degradation, self-recoverable.
IEC 801-3:1984 /EN 50082-1  1992 ; 3 V/m,  1 kHz 80% AM, 27-1000 MHz	PASS - Temporary degradation, self-recoverable.
IEC 801-4:1988 /EN 50082-1  1992 : 0.5 kV Sig Lines, 1kV Power Lines	PASS - Normal operation, no effect.

---

## Warranty

This Agilent Technologies instrument product is warranted against defects in material and workmanship for a period of one year from date of shipment. During the warranty period, Agilent Technologies will, at its option, either repair or replace products which prove to be defective.

For warranty service or repair, this product must be returned to a service facility designated by Agilent Technologies. Buyer shall prepay shipping charges to Agilent Technologies and Agilent Technologies shall pay shipping charges to return the product to Buyer. However, Buyer shall pay all shipping charges, duties, and taxes for products returned to Agilent Technologies from another country.

Agilent Technologies warrants that its software and firmware designated by Agilent Technologies for use with an instrument will execute its programming instructions when properly installed on that instrument. Agilent Technologies does not warrant that the operation of the instrument, or software, or firmware will be uninterrupted or error-free.

### LIMITATION OF WARRANTY

The foregoing warranty shall not apply to defects resulting from improper or inadequate maintenance by Buyer, Buyer-supplied software or interfacing, unauthorized modification or misuse, operation outside of the environmental specifications for the product, or improper site preparation or maintenance.

NO OTHER WARRANTY IS EXPRESSED OR IMPLIED. AGILENT TECHNOLOGIES SPECIFICALLY DISCLAIMS THE IMPLIED WARRANTIES OF MERCHANTABILITY AND FITNESS FOR A PARTICULAR PURPOSE.

### EXCLUSIVE REMEDIES

THE REMEDIES PROVIDED HEREIN ARE BUYER'S SOLE AND EXCLUSIVE REMEDIES. AGILENT TECHNOLOGIES SHALL NOT BE LIABLE FOR ANY DIRECT, INDIRECT, SPECIAL, INCIDENTAL, OR CONSEQUENTIAL DAMAGES, WHETHER BASED ON CONTRACT, TORT, OR ANY OTHER LEGAL THEORY.

---

## Assistance

*Product maintenance agreements and other customer assistance agreements are available for Agilent Technologies products.*

*For any assistance, contact your nearest Agilent Technologies Sales and Service Office.*

When an instrument is returned to a Agilent Technologies service office for servicing, it must be adequately packaged and have a complete description of the failure symptoms attached.

When describing the failure, please be as specific as possible about the nature of the problem. Include copies of additional failure information (such as instrument failure settings, data related to instrument failure, and error messages) along with the instrument being returned.

Please notify the service office before returning your instrument for service. Any special arrangements for the instrument can be discussed at this time. This will help the Agilent Technologies service office repair and return your instrument as quickly as possible.

The original shipping containers should be used. If the original materials were not retained, identical packaging materials are available through any Agilent Technologies office.

---

### **CAUTION**

Instrument damage can result from using packaging materials other than the original materials. Never use styrene pellets as packaging material. They do not adequately cushion the instrument or prevent it from shifting in the carton. They may also cause instrument damage by generating static electricity.

---

---

## Sales and service offices

Agilent Technologies has sales and service offices located around the world to provide complete support for Agilent Technologies products. To obtain servicing information or to order replacement parts, contact the nearest

Agilent Technologies Sales and Service Office. In any correspondence or telephone conversation, refer to the instrument by its model number, serial number, and option designation.

Before returning an instrument for service, call the Agilent Technologies Instrument Support Center at (800) 403-0801, visit the Test and Measurement Web Sites by Country page at <http://www.tm.agilent.com/tmo/country/English/index.html>, or call one of the numbers listed below.

**Agilent Technologies Service Numbers**

Austria	01/25 125-7171
Belgium	32-2-778.37.71
Brazil	11  7297-8600
China	86 10 6261 3819
Denmark	45 99 12 88
Finland	358-10-855-2360
France	01.69.82.66.66
Germany	0180/524-6330
India	080-34 35788
Italy	+ 39 02 9212 2701
Ireland	01 615 8222
Japan	81 -426-56-7832
Korea	82/2-3770-0419
Mexico	5  258-4826
Netherlands	020-547 6463
Norway	22 73 57 59
Russia	+ 7-095-797-3930
Spain	34/91  631 1213
Sweden	08-5064 8700
Switzerland	01  735 7200
United Kingdom	01 344 366666
United States and Canada	800  403-0801

---

## Electrostatic Discharge Information

Electrostatic discharge (ESD) can damage or destroy electronic components. All work on electronic assemblies should be performed at a static-safe work station. Figure 0-1 shows an example of a static-safe work station using two types of ESD protection:

- Conductive table-mat and wrist-strap combination.
- Conductive floor-mat and heel-strap combination.

Both types, when used together, provide a significant level of ESD protection. Of the two, only the table-mat and wrist-strap combination provides adequate ESD protection when used alone.

To ensure user safety, the static-safe accessories must provide at least  $1\text{ M}\Omega$  of isolation from ground. Refer to Table 0-1 for information on ordering static-safe accessories.

---

**WARNING**

---

These techniques for a static-safe work station should not be used when working on circuitry with a voltage potential greater than 500 volts.

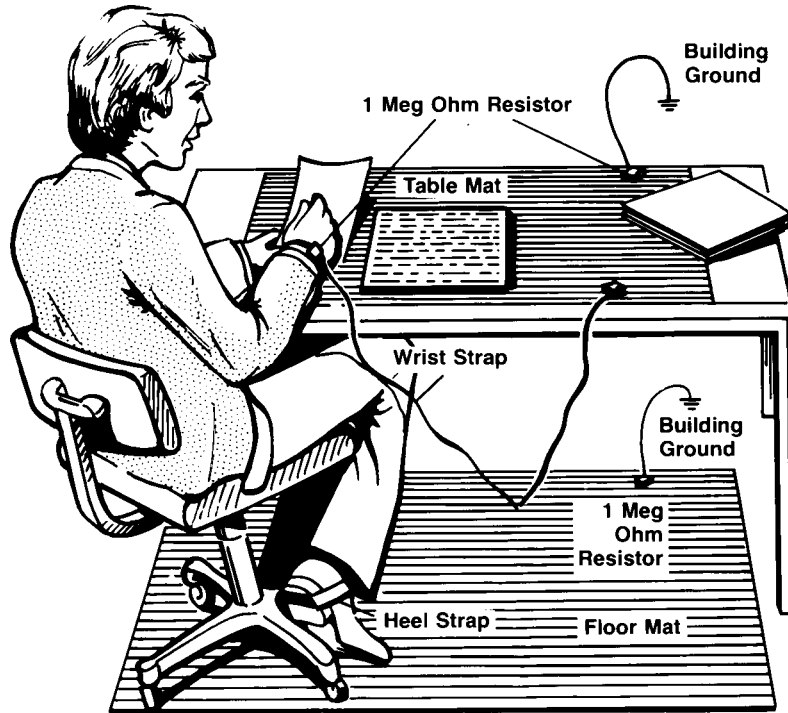

Figure 0-1. Example of a static-safe work station.

**Reducing ESD Damage**

The following suggestions may help reduce ESD damage that occurs during testing and servicing operations.

- Personnel should be grounded with a resistor-isolated wrist strap before removing any assembly from the unit.
- Be sure all instruments are properly earth-grounded to prevent a buildup of static charge.

Table 0-1 lists static-safe accessories that can be obtained from Agilent Technologies using the Agilent part numbers shown.

**Table 0-1. Static-Safe Accessories**

<b>Agilent Part Number</b>	<b>Description</b>
9300-0797	Set includes: 3M static control mat 0.6 m × 1.2 m [2 ft × 4 ft] and 4.6 cm [15 ft] ground wire. [The wrist-strap and wrist-strap cord are not included. They must be ordered separately.]
9300-0980	Wrist-strap cord 1.5 m [5 ft]
9300-1383	Wrist-strap, color black, stainless steel, without cord, has four adjustable links and a 7 mm post-type connection.
9300-1169	ESD heel-strap [reusable 6 to 12 months].



---

# Lightwave Connector Care

---

## CAUTION

---

Improper connector care, cleaning, or use of mismatched cable connectors can invalidate the published specifications and damage connectors. Clean all cables before applying to any connector. Repair of damaged connectors due to improper use is not covered under warranty.

## Introduction

Lightwave cable interfaces can be damaged by improper cleaning and connection procedures. Dirty or damaged lightwave interfaces can result in nonrepeatable or inaccurate measurements. This chapter will suggest some best practices to clean, care for, connect, and inspect lightwave connectors.

**Lightwave connectors** are used to connect two fiber ends together. These connections may be used to join cables between optical ports on devices, laser sources, receivers, patch panels, terminals and many other types of systems or components.

**Fiber optic cables** are used at different wavelengths, in single or multimode, and in different environments. There are a variety of sizes, core/cladding combinations, jackets, and indexes of refraction. In general, different types of cables do not work well together. Cables should match each other and the system.

However, regardless of the cable type, the connectors have only one function: to provide a direct and low-loss optical signal transition from one fiber end to another. When these connectors are used in a measurement system, repeatability becomes an important factor.

**Lightwave connectors differ from electrical or microwave system connectors.** In a fiber optic system, light is transmitted through an extremely small fiber core. Because fiber cores are often 62.5 microns (0.0625 mm) or less in diameter, and dust particles range from tenths of a micron to several microns in diameter, dust and very minute contamination on the end of the fiber core can degrade the performance of the connector interface (where the two cores meet). Therefore, the connector must be precisely aligned and the connector interface free of trapped foreign material.

**Connector (or insertion) loss is one important performance characteristic of a lightwave connector.** Typical values are less than 1 dB of loss, and sometimes as little as 0.1 dB of loss with high performance connectors.

Return loss is another important factor. It is a measure of reflection. The less reflection the better, (the larger the return loss, the smaller the reflection). The best physically contacting connectors have return losses better than 50 dB, although 30 to 40 dB is more common.

Causes of connector loss and reflections include core misalignment, differences in the numerical aperture of two fibers, spacing and air gaps, reflections caused by damaged, worn, or loose fiber ends, and the improper use and removal of index matching compounds.

Achieving the best possible connection, where the fiber end faces are flush (no air gap) and properly aligned, depends on two things:

1. the type of connector
2. using the proper cleaning and connecting techniques. If the connection is lossy or reflective, light will not make a smooth transition. If the transition is not smooth or the connection is not repeatable, measurement data will be less accurate. For this reason, lightwave connections can make a critical difference in optical measurement systems.

## Cleaning and handling

Proper cleaning and handling of lightwave connectors is imperative for achieving accurate and repeatable measurements with your Agilent Technologies lightwave equipment. Lightwave interfaces should be cleaned before each measurement using the techniques described in this handbook. Information on protecting and storing your connectors/cables and tips on how to properly mate connectors are also included in this section.

### Definition of terms

To avoid confusion, the following definitions are used in this handbook.

Connector	Houses the fiber end, most open at the end of a lightwave cable or on the front panel of an instrument or accessory.
Adapter	Does not contain optical fiber. Used to mate two optical connectors.

### Handling

Always handle lightwave connectors and cable ends with great care. Fiber ends should never be allowed to touch anything except other mating surfaces or cleaning solutions and tools.

Always keep connectors and cable ends covered with a protective cap when they are not in use. (See "Storage.")

### Cleaning

Two cleaning processes are provided. The first process describes how to clean non-lensed lightwave connectors. The second process describes how to clean lightwave adapters.

---

## CAUTION

---

Agilent Technologies strongly recommends index matching compounds NOT be applied to their instruments and accessories. Some compounds, such as gels, may be difficult to remove and can contain damaging particulates. If you think the use of such compounds is necessary, refer to the compound manufacturer for information on application and cleaning procedures.

**Cleaning non-lensed  
lightwave connectors**

**Equipment**

The following is a list of the items that should be used to clean non-lensed lightwave connectors.

- Pure isopropyl alcohol .....
- Cotton swabs ..... Agilent part number 8520-0023
- Foam swabs ..... Agilent part number 9300-1223
- Compressed air ..... Agilent part number 8500-5262

---

**CAUTION**

---

Agilent Technologies recommends you do not use any type of foam swab to clean optical fiber cable ends. Foam swabs can leave filmy deposits on fiber ends that can degrade performance. However, foam *is* required to clean inside bulk head connectors.

**Process**

Before cleaning the fiber end, clean the ferrules and other parts of the connector. Use isopropyl alcohol, clean cotton swabs, and clean compressed air. Then use alcohol to clean the fiber end. Some amount of wiping or mild scrubbing of the fiber end can help remove particles when application of alcohol alone will not remove them. This can be done by applying the alcohol to a cotton swab and moving it back and forth across the fiber end several times. This technique can help remove or displace particles smaller than one micron.

Allow the connector to dry (about a minute) or dry it immediately with clean compressed air. Compressed air lessens the chance of deposits remaining on the fiber end after the alcohol evaporates. It should be blown horizontally across the fiber end. Visually inspect the fiber end for stray cotton fibers. As soon as the connector is dry, the connection should be made.

---

**CAUTION**

---

Inverting the compressed air canister while spraying will produce residue on the sprayed surface. Refer to instructions provided on the compressed air canister.

**Cleaning lightwave adapters**

**Equipment**

All of the items listed above for cleaning connectors may be used to clean lightwave adapters. In addition, small foam swabs may be used along with isopropyl alcohol and compressed air to clean the inside of lightwave connector adapters.

**NOTE**

As noted in a previous caution statement, the foam swabs can leave filmy deposits. These deposits are very thin however, and the risk of other contamination buildup on the inside of adapters greatly outweighs the risk of contamination of foam swab deposits left from cleaning the inside of adapters.

**Process**

Clean the adapter by applying isopropyl alcohol to the inside of the connector with a foam swab. Allow the adapter to air dry, or dry it immediately with clean compressed air.

**Storage**

All of Agilent Technologies' lightwave instruments are shipped with either laser shutter caps or dust caps on the lightwave adapters that come with the instrument. Also, all of the cables that are shipped have covers to protect the cable ends from damage or contamination. These dust caps and protective covers should be kept on the equipment except when in use.

**Making connections**

Proper connection technique requires attention to connector compatibility, insertion technique and torque requirements. Connectors must be the same connector type in order to ensure mechanical and optical compatibility. Attempting to connect incompatible connector types may prevent the connection from functioning properly and even cause damage to the fiber surfaces. A visual inspection of the mechanical interfaces may not be enough because some connector types have the same mechanical interface but have different optical fiber interfaces (for example, angled-no-contact, angled-contact or straight-contact fiber interfaces). Refer to the manufacturer's data sheet to confirm connector type compatibility before connecting.

When you insert the ferrule into an adapter, make sure the fiber end does not touch the outside of the mating adapter. This ensures you will not rub the fiber end against any undesirable surface. Many connectors have a keyed slot provided for optimum measurement repeatability that also helps to align and seat the two connectors. After the ferrule is properly seated inside the other connector, use one hand to keep it straight, rotate it to align the key, and tighten it with the other hand.

Most connectors using springs to push fiber ends together exert one to two pounds of force. Over-tightening or under-tightening these connectors can result in misalignment and nonrepeatable measurements. Always finger tighten the connector in a consistent manner. Refer to the manufacturer's data sheet for any torque recommendations.

---

**CAUTION**

---

OPTION 3XX INSTRUMENTS: To avoid damage, handle the pigtail fiber with care. Use only an appropriate fiber cleaver tool for cutting the fiber. Do not pull the bare fiber out of its jacket, crush it, kink it, or bend it past its minimum bend radius.

**Summary**

When making measurements with lightwave instruments or accessories, the following precautions will help to insure good, reliable, repeatable measurements:

- Confirm connector type compatibility.
- Use extreme care in handling all lightwave cables and connectors.
- Be sure the connector interfaces are clean before making any connections.
- Use the cleaning methods described in this handbook.
- Keep connectors and cable ends covered when not in use.

## Inspection

### Visual inspection

Although it is not necessary, visual inspection of fiber ends can be helpful. Contamination and/or imperfections on the cable endface can be detected as well as cracks or chips in the fiber itself.

Several fiber inspection scopes are on the market, but any microscope with an enlargement range of 100X to 200X can be used. It is helpful to devise some method to hold the fiber in place while viewing in this range.

Inspect the entire endface for contamination, raised metal, or dents in the metal, as well as any other imperfections. Inspect the fiber core for cracks and chips.

Visible imperfections not touching the fiber core may not affect the performance of the lightwave connection (unless the imperfections keep the fibers from contacting). Consistent optical measurements are the best assurance that your lightwave connection is performing properly.

---

## WARNING

---

Always remove both ends of fiber-optic cables from any instrument, system, or device before visually inspecting the fiber ends. Disable all optical sources before disconnecting fiber-optic cables. Failure to do so may result in permanent injury to your eyes.

## Optical performance testing

### Introduction

Consistent measurements with your lightwave equipment are a good indication that you have good connections. However, you may wish to know the insertion loss and/or return loss of your lightwave cables or accessories. If you test your cables and accessories for insertion loss and return loss upon receipt, and retain the measured data for comparison, you will be able to tell in the future if any degradation has occurred.

### Insertion loss

Insertion loss can be tested using a number of different test equipment configurations. Some of these are:

- an Agilent 8702B or Agilent 8703A lightwave component analyzer system with a lightwave source and receivers
- an Agilent 83420 lightwave test set with an Agilent 8510 network analyzer

- an Agilent 8153A lightwave multimeter with a source and a power sensor module

Many other possibilities exist. The basic requirements are an appropriate lightwave source and a compatible lightwave receiver. Refer to the manuals provided with your lightwave test equipment for information on how to perform an insertion loss test.

Typical insertion loss for cables is less than 1 dB, and can be as little as 0.1 dB. For actual specifications on your particular cable or accessory, refer to the manufacturer.

#### Return loss

Return loss can be tested using a number of different test equipment configurations. Some of these are:

- an Agilent 8703A lightwave component analyzer
- an Agilent 8702B lightwave component analyzer with the appropriate source, receiver and lightwave coupler
- an Agilent 8504B precision reflectometer
- an Agilent 8153A lightwave multimeter and Agilent 81534A return loss module

Many other possibilities exist. The basic requirements are an appropriate lightwave source, a compatible lightwave receiver, and a compatible lightwave coupler.

Refer to the manuals provided with your lightwave test equipment for information on how to perform a return loss test.

Typical return loss for single mode units is better than 40 dB. For actual specifications on your particular cable or accessory, refer to the manufacturer.



---

## In This Book

This manual provides information about the Agilent 83480A-series digital communications analyzers and the Agilent 54750A-series digitizing oscilloscopes.

<b>Part 1</b> <b>Introduction</b>	Chapter 1	gives you a brief overview of the instrument and describes the menu and key conventions and the front and rear panels of the instrument.
	Chapter 2	describes the front panel keys and functions.
	Chapter 3	lists the specifications and characteristics of the instrument.
	Chapter 4	gives an overview of the calibration options.
<b>Part 2</b> <b>Digital Communications Analyzer Functions</b>	Chapter 5	gives the eye, mask and eyeline measurement tutorials.
	Chapter 6	describes the mask test, measure eye, channel setup, time base and trigger menus.
<b>Part 3</b> <b>Digitizing Oscilloscope Functions</b>	Chapter 7	describes the automatic waveform measurement process.
	Chapter 8	describes how to use the built-in automatic measurements.
	Chapter 9	describes how to increase measurement accuracy and how to make time-interval measurements.
	Chapter 10	describes the acquisition, channel setup, define measure, FFT, histogram, math, time base and trigger menus.
<b>Part 4</b> <b>System Functions</b>	Chapter 11	describes the disk, display, limit test, marker, setup, setup print, utility and waveform menus.
	Chapter 12	provides a list of messages that may appear on the instrument's display.
	Chapter 13	describes basic instrument architecture.



---

# Contents

Sales and service offices . . . . .	xii
<b>1. The Instrument at a Glance</b>	
Ordering Information . . . . .	1-5
Menu and Key Conventions . . . . .	1-7
The Front Panel . . . . .	1-9
Autoscale . . . . .	1-10
Display . . . . .	1-11
Entry devices . . . . .	1-13
Indicator lights . . . . .	1-14
The Rear Panel . . . . .	1-15
<b>2. General Purpose Keys</b>	
The Clear Display Key . . . . .	2-3
The Fine Function . . . . .	2-4
The Help Key . . . . .	2-5
The Local Key . . . . .	2-6
The Run Key . . . . .	2-7
The Stop/Single Key . . . . .	2-8
<b>3. Specifications and Characteristics</b>	
Horizontal System . . . . .	3-3
Trigger Specifications Electrical and Optical Channels . . . . .	3-4
Standard instrument, 2.5 GHz mode . . . . .	3-4
Option 100, 12 GHz mode . . . . .	3-5
Option 100, 12 GHz/Gate mode . . . . .	3-5
General Specifications . . . . .	3-6
<b>4. Calibration Overview</b>	
Factory Calibrations . . . . .	4-4
Mainframe Calibration . . . . .	4-4
O/E Factory Wavelength Calibration . . . . .	4-6
User Calibrations—Optical and Electrical . . . . .	4-8
O/E User-Wavelength Calibration . . . . .	4-10
Plug-in Module Vertical Calibration . . . . .	4-12
Offset Zero Calibration . . . . .	4-13
Dark Calibration . . . . .	4-15

Channel Skew Calibration . . . . .	4-16
Probe Calibration . . . . .	4-17
External Scale . . . . .	4-19
Complete Calibration Summary . . . . .	4-21

**5. Eye, Mask and Eyeline Mode Measurement Tutorials**

Making Eye Diagram Measurements . . . . .	5-3
Setting up the system . . . . .	5-4
Positioning the waveform . . . . .	5-5
Making the measurement . . . . .	5-9
Measuring extinction ratio . . . . .	5-10
Measuring eye height . . . . .	5-13
Measuring crossing % . . . . .	5-14
Measuring eye width . . . . .	5-15
Measuring jitter . . . . .	5-16
Measuring duty cycle distortion . . . . .	5-17
Measuring Q-factor . . . . .	5-19
Measuring rise time . . . . .	5-21
Measuring fall time . . . . .	5-23
Testing to a Mask . . . . .	5-25
Setting up the system . . . . .	5-27
Positioning the waveform . . . . .	5-28
Making the measurement . . . . .	5-31
Standard Mask . . . . .	5-32
Making Eyeline Measurements (Agilent 83480A Option 001 only) . . . . .	5-37
Eyeline traces . . . . .	5-38
Noise reduction . . . . .	5-40
Error trace capture . . . . .	5-42
Equipment configuration/program installation . . . . .	5-43
Error trace capture . . . . .	5-49

**6. The Digital Communications Analysis Menus**

Mask Test Menu . . . . .	6-3
Scale Mask . . . . .	6-19
Mask Align . . . . .	6-21
Align Mode . . . . .	6-22
Run... . . . .	6-23
Fail action... . . . .	6-25

Measure Eye Menu . . . . .	6-30
Extinction ratio... . . . .	6-32
Eye height . . . . .	6-35
Crossing % . . . . .	6-36
Eye width . . . . .	6-38
Jitter . . . . .	6-39
Duty cycle distortion... . . . .	6-40
Q-factor . . . . .	6-41
Channel Setup Menu . . . . .	6-43
Time Base Menu . . . . .	6-44
Units . . . . .	6-45
Bit Rate . . . . .	6-45
Scale . . . . .	6-46
Position . . . . .	6-46
Reference . . . . .	6-47
Time base windowing... . . . .	6-48
Window Position . . . . .	6-49
Trigger Menu . . . . .	6-50
Trigger Basics . . . . .	6-50
Sweep . . . . .	6-51
Source . . . . .	6-51
External Scale . . . . .	6-52
Level . . . . .	6-52
Slope . . . . .	6-52
Hysteresis . . . . .	6-53
Trig Bandwidth . . . . .	6-53

<b>7. Waveform Measurements</b>	
How to Make Waveform Measurements . . . . .	7-3
The Waveform Measurement Process . . . . .	7-4
Data collection . . . . .	7-5
Building a histogram . . . . .	7-6
Calculating min and max from the data record . . . . .	7-7
Calculating top and base . . . . .	7-8
Locating crossing points . . . . .	7-9
Calculating thresholds . . . . .	7-10
Determining rising and falling edges . . . . .	7-11
Standard Waveform Definitions . . . . .	7-14
Voltage and power measurements . . . . .	7-14
Timing definitions . . . . .	7-17
User-defined $\Delta$ time . . . . .	7-19
Some important measurement considerations . . . . .	7-20
<b>8. Making Automatic Measurements</b>	
Period and frequency measurements . . . . .	8-3
Pulse width measurements . . . . .	8-4
Rise time, fall time, preshoot, and overshoot measurements . . . . .	8-4
Front Panel Measure Section . . . . .	8-5
$\Delta$ time . . . . .	8-5
+width . . . . .	8-6
-width . . . . .	8-6
Duty Cycle . . . . .	8-6
Fall Time . . . . .	8-7
Frequency . . . . .	8-7
Overshoot . . . . .	8-7
Period . . . . .	8-8
Preshoot . . . . .	8-8
Rise Time . . . . .	8-8
Vamp . . . . .	8-9
Vbase . . . . .	8-9
Vpp . . . . .	8-9
Vrms . . . . .	8-10

Vtop	8-10
General Meas Menu	8-11
Tmax	8-12
Tmin	8-12
Vavg	8-12
Vlower	8-13
Vmiddle	8-13
Vupper	8-13
Avg Power Menu	8-14
Avg Power	8-14
Freq Domain Menu	8-15
FFT freq	8-15
FFT mag	8-15
FFT Δfreq	8-16
FFT Δmag	8-16
Source	8-17
Peak number	8-17
Pk threshold	8-18
Histogram Menu	8-19
$\mu \pm 1\sigma$	8-19
$\mu \pm 2\sigma$	8-19
$\mu \pm 3\sigma$	8-20
hits	8-20
mean	8-20
median	8-21
peak	8-21
pk-pk	8-21
std dev	8-22

<b>9. Increasing Measurement Accuracy and Time-Interval Measurement</b>	
Increasing Measurement Accuracy . . . . .	9-3
Measuring time intervals . . . . .	9-3
Automatic measurements . . . . .	9-4
Markers . . . . .	9-5
Channel-to-channel measurements . . . . .	9-5
Statistics . . . . .	9-5
Jitter and Averaging . . . . .	9-8
Time-Interval Measurements . . . . .	9-9
dc errors . . . . .	9-9
Vertical quantization . . . . .	9-13
Summary of dc errors . . . . .	9-13
Dynamic response errors . . . . .	9-14
Rise time response . . . . .	9-15
<b>10. General Purpose Oscilloscope Menus</b>	
Acquisition Menu . . . . .	10-3
Averaging . . . . .	10-4
Best . . . . .	10-5
Record length... . . . .	10-6
Channel Setup Menu . . . . .	10-7
Define Measure Menu . . . . .	10-8
Thresholds... . . . .	10-9
Top-base . . . . .	10-11
Standard . . . . .	10-12
User Defined . . . . .	10-13
Define $\Delta$ time . . . . .	10-14
Start Edge or Stop Edge . . . . .	10-14
Edge Number . . . . .	10-15
Edge Threshold . . . . .	10-15
Color grade... . . . .	10-16
Signal type . . . . .	10-16
Eye window 1 and Eye window 2 . . . . .	10-17
Meas Complete . . . . .	10-18



Statistics . . . . .	10-18
Off . . . . .	10-19
mean, stddev . . . . .	10-20
min, max . . . . .	10-21
FFT Menu . . . . .	10-22
Display . . . . .	10-23
Source . . . . .	10-23
Window . . . . .	10-24
FFT Scaling . . . . .	10-25
Magnify . . . . .	10-26
Y-Scale . . . . .	10-27
Y-Offset . . . . .	10-27
Other FFT measurements . . . . .	10-28
FFT basics . . . . .	10-28
Frequency measurements . . . . .	10-31
Frequency accuracy . . . . .	10-31
Amplitude measurements . . . . .	10-32
Computation of dBm . . . . .	10-33
Computation of dBV . . . . .	10-34
dc value . . . . .	10-34
Aliasing . . . . .	10-35
Presetting FFT parameters . . . . .	10-35
Histogram Menu . . . . .	10-36
Histograms in the instrument . . . . .	10-37
Mode . . . . .	10-40
Axis . . . . .	10-40
Histogram Window . . . . .	10-41
Histogram Scale . . . . .	10-43
Run Until . . . . .	10-45
Math Menu . . . . .	10-46
Function . . . . .	10-47
Define Function . . . . .	10-47
Display . . . . .	10-51
Time Base Menu . . . . .	10-53
Units . . . . .	10-54

Bit rate . . . . .	10-54
Scale . . . . .	10-55
Position . . . . .	10-55
Reference . . . . .	10-56
Time base windowing . . . . .	10-57
Main . . . . .	10-57
Window . . . . .	10-57
Window Scale . . . . .	10-57
Window Position . . . . .	10-58
Trigger Menu . . . . .	10-59
Trigger basics . . . . .	10-60
Sweep . . . . .	10-60
Source . . . . .	10-61
External Scale . . . . .	10-62
Level . . . . .	10-62
Slope . . . . .	10-63
Hysteresis . . . . .	10-63
Trig Bandwidth . . . . .	10-63

## 11. The General Function Menus

Disk Menu . . . . .	11-3
directory . . . . .	11-4
load . . . . .	11-6
store . . . . .	11-8
delete . . . . .	11-10
format . . . . .	11-10
Type . . . . .	11-11
Format . . . . .	11-14
Mask Formats . . . . .	11-21
From File , To File , or File Name . . . . .	11-22
To memory . . . . .	11-23
Display Menu . . . . .	11-24

Persistence . . . . .	11-25
Color grade... . . . .	11-27
draw waveform . . . . .	11-27
Graticule . . . . .	11-31
Label . . . . .	11-34
Delete... . . . .	11-37
Color . . . . .	11-38
Limit Test Menu . . . . .	11-42
Test . . . . .	11-44
Measurement . . . . .	11-44
Fail When . . . . .	11-45
Upper Limit . . . . .	11-47
Lower Limit . . . . .	11-47
Run Until . . . . .	11-48
Fail Action . . . . .	11-50
Marker Menu . . . . .	11-56
off . . . . .	11-57
manual . . . . .	11-57
waveform . . . . .	11-59
measurement . . . . .	11-61
histogram . . . . .	11-62
TDR/TDT . . . . .	11-62
Setup Menu . . . . .	11-64
Setup memory . . . . .	11-65
Save . . . . .	11-65
Recall . . . . .	11-66
Default setup . . . . .	11-66
Setup Print Menu . . . . .	11-70
Print format . . . . .	11-72
Destination . . . . .	11-74
Data . . . . .	11-76
TIFF and GIF files on the Apple Macintosh Computer . . . . .	11-77

Utility Menu . . . . .	11-78
HP-IB Setup... . . . .	11-79
System config... . . . .	11-80
Calibrate... . . . .	11-85
Self-test... . . . .	11-88
Firmware support... . . . .	11-89
Service... . . . .	11-90
Waveform Menu . . . . .	11-93
waveform . . . . .	11-94
Pixel . . . . .	11-97

**12. Messages**

Instrument Messages . . . . .	12-2
Messages you may see on your instrument . . . . .	12-2

**13. How the Instrument Works**

Basics of Sequential Sampling . . . . .	13-3
System Architecture . . . . .	13-8
The major plug-in module hardware components . . . . .	13-9
The major mainframe hardware components . . . . .	13-10
Probe selection . . . . .	13-12
System bandwidth . . . . .	13-17
Probe types . . . . .	13-18
Summary . . . . .	13-21
Standard and Enhanced Trigger Modes . . . . .	13-22
DC-2.5 GHz mode . . . . .	13-22
DC-100 MHz mode . . . . .	13-22
2-12 GHz mode ( <i>Option 100 only</i> ) . . . . .	13-23
12 GHz/Gate mode ( <i>Option 100 only</i> ) . . . . .	13-25

**Index**

---

## Figures

0-1. Example of a static-safe work station. . . . .	xv
1-1. The instrument front panel. . . . .	1-9
1-2. The instrument display. . . . .	1-11
1-3. The instrument rear panel. . . . .	1-15
2-1. The Help menu. . . . .	2-5
4-1. Current Frame $\Delta$ Temp condition . . . . .	4-6
4-2. Plug-in calibration menu . . . . .	4-11
4-3. Offset Zero Calibration . . . . .	4-14
4-4. Dark calibration menu . . . . .	4-16
4-5. Electrical Channel Calibrate Menu . . . . .	4-18
4-6. External Scale Menu . . . . .	4-20
5-1. Setting up your measurement system. . . . .	5-4
5-2. Position of data waveform. . . . .	5-5
5-3. Extinction ratio measurement. . . . .	5-11
5-4. Eye height measurement. . . . .	5-13
5-5. Crossing percentage measurement. . . . .	5-14
5-6. Eye width measurement. . . . .	5-15
5-7. Jitter measurement. . . . .	5-16
5-8. Duty cycle distortion measurement. . . . .	5-17
5-9. Q-factor measurement. . . . .	5-20
5-10. Rise time measurement. . . . .	5-21
5-11. Fall time measurement. . . . .	5-23
5-12. Setting up the measurement. . . . .	5-27
5-13. Position of data waveform. . . . .	5-28
5-14. Eye with a mask. . . . .	5-32
5-15. Mask with a 20% margin set. . . . .	5-35
5-16. Conventional eye diagram display. . . . .	5-38
5-17. Similar eye diagram in eyeline mode. . . . .	5-39
5-18. Conventional eye diagram of a low power signal. . . . .	5-40
5-19. Low power signal viewed with eyeline mode using averaging. . . . .	5-41
5-20. Mask violation and the sequence leading to the violation. . . . .	5-42
5-21. Front panel connection for eyeline mode. . . . .	5-43
5-22. Rear panel connection for eyeline mode. . . . .	5-44
5-23. Display after initial mask alignment. . . . .	5-50
5-24. Display after time base position adjustment. . . . .	5-50
5-25. Error trace capture example. . . . .	5-51
6-1. Legal and illegal polygon construction. . . . .	6-12

## Contents

6-2. Defining a polygon. . . . .	6-15
6-3. Rescaling a polygon. . . . .	6-16
6-4. Mask with a 15% margin. . . . .	6-17
6-5. Extinction ratio measurement. . . . .	6-33
6-6. Eye height measurement. . . . .	6-35
6-7. Crossing % measurement. . . . .	6-37
6-8. Eye width measurement. . . . .	6-38
6-9. Jitter measurement. . . . .	6-39
6-10. Duty cycle distortion measurement. . . . .	6-40
6-11. Measuring Q-factor. . . . .	6-42
7-1. Pulse parameters the instrument measures. . . . .	7-3
7-2. The instrument uses this process for waveform measurement. . . . .	7-5
7-3. Some measurements are made from the histogram. . . . .	7-6
7-4. The middle 20 percent of the waveform is ignored. . . . .	7-8
7-5. Calculating the 10, 50, and 90 percent thresholds. . . . .	7-10
7-6. Thresholds are used to determine edges. . . . .	7-11
7-7. The system ignores incomplete transitions when defining edges. . . . .	7-12
7-8. Waveform period is measured at the middle threshold. . . . .	7-13
7-9. Waveform definitions used to make voltage measurements. . . . .	7-15
7-10. You may define $\Delta$ time. . . . .	7-19
9-1. Erroneous rise time measurements due to jitter. . . . .	9-8
9-2. Effect of vertical dc errors on measurement accuracy. . . . .	9-10
9-3. Edges of opposite polarity reinforce dc errors. . . . .	9-11
9-4. Faster transitions decrease effect of dc offset errors. . . . .	9-12
9-5. Measure time intervals at fastest-changing part of transition. . . . .	9-12
9-6. Narrow pulse applied to the instrument. . . . .	9-16
9-7. Errors in pulse height measurement. . . . .	9-17
9-8. Error in pulse width at 10% level is approximately equal to the error in 10%-90% rise time. . . . .	9-18
9-9. Effect of probe capacitance. . . . .	9-19
10-1. Standard measurement thresholds. . . . .	10-8
10-2. Standard deviations of a Gaussian distribution. . . . .	10-20
10-3. Sine wave in the frequency domain. . . . .	10-29
10-4. An FFT display. . . . .	10-30
10-5. An example of the histogram display. . . . .	10-38
11-1. The Directory display. . . . .	11-4
11-2. Dots only. . . . .	11-28
11-3. Connected dots. . . . .	11-29
11-4. Screen in grid mode using one graph. . . . .	11-31
11-5. Screen in frame mode using one graph. . . . .	11-32

11-6. Screen in frame mode using two graphs. . . . .	11-33
11-7. A functional view of the limit test. . . . .	11-43
11-8. Setup Print screen. . . . .	11-71
11-9. The System Configuration display. . . . .	11-80
11-10. A typical Cal Status display. . . . .	11-86
11-11. A typical Firmware support screen. . . . .	11-89
11-12. Storing a waveform. . . . .	11-94
11-13. Saving to pixel memory. . . . .	11-97
13-1. The sampling circuit. . . . .	13-3
13-2. Sequential sampling process. . . . .	13-5
13-3. Acquisition with record length = 64. . . . .	13-6
13-4. Acquisition with record length = 2250. . . . .	13-7
13-5. Hardware block diagram. . . . .	13-8
13-6. The probe is a part of the circuit under test. . . . .	13-12
13-7. Simplified equivalent circuit of DUT and probe. . . . .	13-13
13-8. Reduced amplitude and dc offset caused by probe loading. . . . .	13-14
13-9. Effects of probe capacitance. . . . .	13-15
13-10. Resistive divider probe. . . . .	13-18
13-11. Active probe. . . . .	13-20
13-12. Viewing a 10 Gb/s eye diagram using 12 GHz trigger. . . . .	13-24
13-13. 12 GHz mode jitter with 200 mV p-p sine wave input. . . . .	13-26
13-14. 12 GHz/Gate mode jitter with 300 mV p-p sine wave input. . . . .	13-27
13-15. Gating application. . . . .	13-28
13-16. 2.5 GHz trigger on signal with pulsed 2 GHz RF content. . . . .	13-29
13-17. 12 GHz trigger on signal with pulsed 10 GHz RF content. . . . .	13-29
13-18. 10 Gb/s digital eye diagram without gating. . . . .	13-30
13-19. 10 Gb/s digital eye diagram with a lms gating pulse. . . . .	13-31
13-20. Result of triggering the low speed gating pulse generator from the 10 Gb/s pattern generator. . . . .	13-32

---

## Tables

0-1. Static-Safe Accessories . . . . .	xvi
4-1. Factory Calibration Summary . . . . .	4-4
4-2. Optical and Electrical Channel User Calibration Summary . . . . .	4-9
4-3. Miscellaneous User Calibration Summary . . . . .	4-10
4-4. Complete Calibration Summary . . . . .	4-21
9-1. Rise-Time Measurement Errors . . . . .	9-15
11-1. Partial listing of the Text Verbose Format for a Normal Waveform . . . . .	11-16
11-2. Partial Example of the Text Y Values Format . . . . .	11-20
11-3. Default Setups . . . . .	11-67



**— The Instrument at a  
Glance**

---

## The Instrument at a Glance

### **What you'll find in this chapter**

This chapter provides you with a brief overview of how the instrument functions, descriptions of the front and rear panels, and a description of the key conventions used in this manual. The following topics are discussed:

- options and accessories
- menu and key conventions
- the front panel and rear panel
- the display
- indicator lights
- entry devices
- keys that *do not* display menus on screen

Understanding the information in this chapter will help you operate the instrument. Information on using the front-panel interface is in the *User's Quick Start Guide* supplied with the instrument.

---

The Agilent 83480A-series digital communications analyzer and Agilent 54750A-series digitizing oscilloscopes are powerful and versatile instruments designed for use in research, development, production and evaluation testing in the telecommunication, data communication, RF/microwave and signal integrity areas. Data acquisition and measurement analysis are performed in parallel, enabling the instrument to achieve outstanding measurement throughput. The instrument provides fast, repeatable communications waveform performance analysis with automated pulse and eye diagram statistical measurements. Optical or electrical conformance tests to both user-defined and industry standard eye diagram masks or pulse templates are efficiently executed. The instrument is a modular platform which accepts up to two dual-channel electrical or optical measurement modules.

The instrument provides you with the necessary capabilities to test and measure analog and digital circuits. The instrument provides:

- Optical and electrical measurement channels (*Agilent 83480A only*)
- Optical input wavelength:
  - 750 nm to 860 nm (*Agilent 83480A, with an Agilent 83487A only*)
  - 1000 nm to 1600 nm for (*Agilent 83480A, with an Agilent 83486A*)
  - 1200 to 1600 nm for (*Agilent 83480A, with an Agilent 83485A*)
- Integrated average optical power meter (*Agilent 83480A, with any optical module*)
- Calibrated vertical watts scale (*Agilent 83480A, with any optical module*)
- Up to 50 GHz bandwidth
- TDR/TDT measurements (*Agilent 54750A only, or Agilent 83480A with Agilent 54755A option*)

*This function available with firmware revision A.02.00 and above.*

## The Instrument at a Glance

- Standard masks and templates, (*Agilent 83480A only*) including:

Optical Masks	Electrical Masks
STM0/OC1	STS1 Eye
STM1/OC3	STS1 Pulse
OC12	STS3 Eye
OC24	STS3 Pulse 0
STM16/OC48	STS3 Pulse 1
FC133	DS1
FC266	DS1C
FC531	DS2
FC1063	DS3
FDDI	PDH 2.048 Mb
100BASE-FX	PDH 8.448 Mb
GIGABIT ETHERNET	PDH 34.4 Mb
	PDH 139 Mb 0
	PDH 139 Mb 1

- Automatic mask and template scaling, positioning, and testing
- Statistical waveform analysis
- FFT

---

## Ordering Information

### Supplied accessories

- Power cord for country of destination
- *Agilent 83480A, 54750A Quick Start Guide*
- *Agilent 83480A, 54750A User's Guide*
- *Agilent 83480A, 54750A Programmer's Quick Reference*
- *Agilent 83480A, 54750A Programmer's Guide*
- 9300-1484 ESD kit
- One year warranty

Option 001 *Agilent 83480A only.* Agilent Eyeline Mode software. Loads downloadable eyeline analysis program directly to the internal disk drive. Enables Eyeline Mode operation with an Agilent 71603B, Agilent 71612A (Agilent 70843A) error performance analyzer or Agilent 71604B pattern generator.

Option 100 Provides direct triggering on 12 GHz signals. An external gating signal can be used to further extend the triggering capabilities.

Option 908 Rackmount kit, without handles, Agilent p/n 54710-68704

Option 909 Rackmount kit, for instruments with handles, Agilent p/n 54710-68705

Option 0BW Service guide

Option 0B1 Additional set of user documentation

Option 0B0 Deletes the user documentation

Option UK6 Measured performance data

### Optional accessories

- Agilent 10086A ECL terminator
- Agilent 11898A extender module
- Agilent 54006A 6 GHz divider probe
- Agilent 54008A 22 ns delay line
- Agilent 54118A 500 MHz to 18 GHz trigger
- Agilent 54753A TDR plug-in module
- Agilent 54754A TDR plug-in module
- Agilent 54755A TDR firmware kit (for use with the Agilent 83480A)

**Ordering Information**

Agilent 83480K communications firmware kit (for use with the Agilent 54750A)

Agilent 83482A 40 GHz optical/electrical plug-in module

Agilent 83483A, 54751A electrical plug-in module

Agilent 83484A, 54752A 50 GHz electrical plug-in module

Agilent 83485A optical/electrical plug-in module

Agilent 83485B high speed optical/electrical plug-in module

Agilent 83486A 1300-1500 nm multimode optical/electrical plug-in module

Agilent 83487A 850 nm multimode optical/electrical plug-in module

Blank, one (1) slot filler plug-in, Agilent part number 54700-68702 or

Agilent 54700B

**Connection devices**

SMA (f-f) adapter, Agilent part number 1250-1158

APC 3.5 (f-f) adapter, Agilent part number 1250-1749

---

## Menu and Key Conventions

The keys labeled Trigger, Disk, and Run are all examples of front-panel keys. Pressing some front-panel keys accesses menus of functions that are displayed along the right side of the display screen. These menus are called softkey menus.

Softkey menus list functions other than those accessed directly by the front-panel keys. To activate a function on the softkey menu, press the unlabeled key immediately next to the annotation on the screen. The unlabeled keys next to the annotation on the display are called softkeys.

Additional functions are listed in blue type above and below some of the front-panel keys. These functions are called shifted functions. To activate a shifted function, press the blue front-panel Shift key and the front-panel key next to the desired function.

Throughout this manual front-panel keys are indicated by a box around the key label, for example, **Timebase**. Softkeys are indicated by shading on the key label, for example, **Scale**. The softkeys displayed depend on the front-panel key pressed and which menu is selected. Shifted functions are indicated by the front-panel **Shift** key (blue key) followed by the shaded shifted function, for example the Local function (above the **Stop/Single** front-panel key) will be shown as **Shift**, **Local**.

A softkey with On and Off in its label can be used to turn the softkey's function on or off. To turn the function on, press the softkey so On is highlighted. To turn the function off, press the softkey so Off is highlighted. An On or Off softkey function will be indicated throughout this manual as: **Test On**.

## Menu and Key Conventions

A softkey such as **Sweep Triggered Freerun** offers you a choice of functions. In this case you could choose Triggered by pressing the softkey until Triggered is highlighted, or choose Freerun by pressing the softkey until Freerun is highlighted. A choices softkey will be indicated throughout this manual as: **Sweep Triggered Freerun** Triggered.

When some softkeys, such as **Eye Height**, are pressed the first time, a measurement will be made and the result will be provided. Some softkeys, such as **Offset** require the entry of a numeric value. To enter or change the value, use the general purpose knob located below the front-panel Measure section.



---

# The Front Panel

The front panel of the instrument includes a display area and several functional areas, including:

- Control
- Measure
- Setup
- Storage
- System
- Autoscale

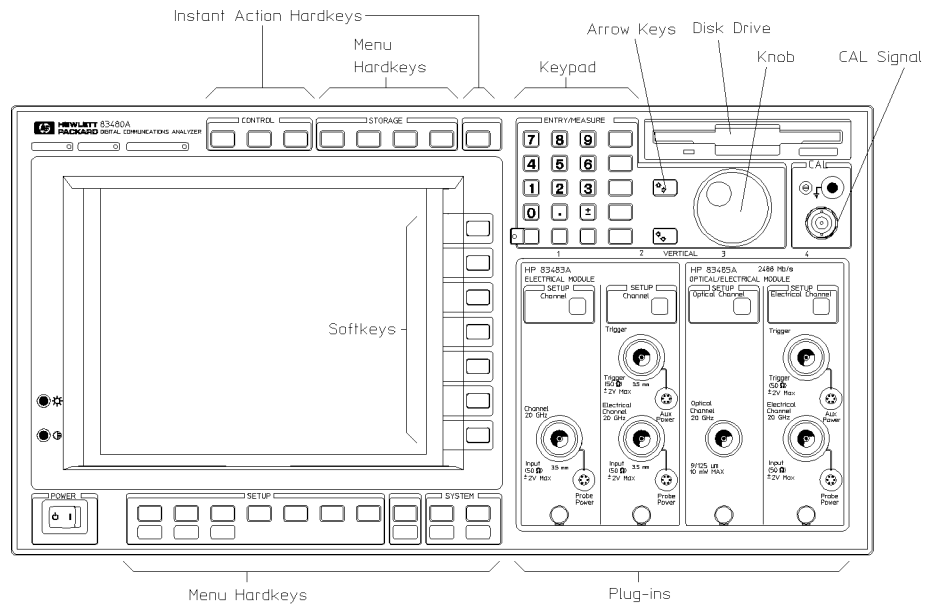

Figure 1-1. The instrument front panel.

54720E02

The display area and Autoscale key are described in this chapter. Information on the other functional areas are included later in this manual.

---

**Autoscale**

The Autoscale key causes the instrument to quickly analyze the signal. Then, it sets up the vertical, horizontal, and trigger to best display that signal. Autoscale can find:

Repetitive signals with:

frequency  $\geq 50$  Hz

duty cycle  $> 1\%$

amplitude  $\geq 10$  mV p-p or  $120 \mu\text{Wp-p}$  (optical signals only on the *Agilent 83480A, 83485A*)

trigger amplitude  $> 20$  mV

Autoscale looks for signals on *all* channels, *even if they are turned off*. It also searches for a trigger signal on the external trigger inputs.

*Agilent 83480A Option 100 only:* If no trigger signal is detected at the external input, and the instrument is in the 2.5 GHz trigger mode, the sweep will stop. If the instrument is in the 12 GHz trigger mode, it will sweep continuously in “freerun” condition.

If the Autoscale key is pressed unintentionally, use the Undo Autoscale function to return the instrument to the settings that existed prior to pressing the Autoscale key. To undo an Autoscale function press:

**Shift**, **Undo Autoscale**

To quickly rescale the vertical axis, *without* altering the timebase, press:

**Channel**

**Channel Autoscale** (only on *Agilent 83480A, 83483A, 83485A*)

## Display

The instrument has a high-resolution, color display. The display is divided into several areas as shown in Figure 1-2.

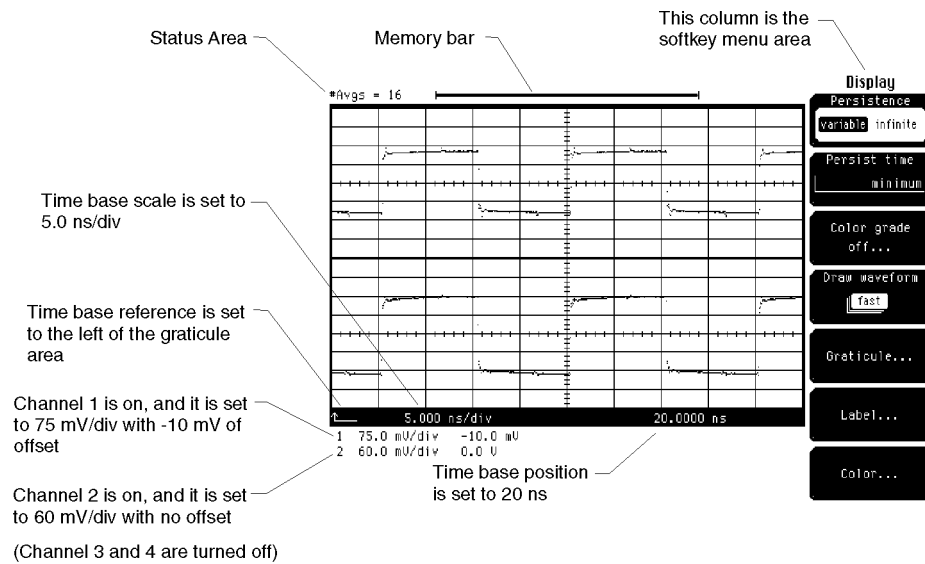

54750s13.cdr

Figure 1-2. The instrument display.

## The Front Panel

- Status area** The Status area displays prompts, messages, error messages, warnings, and the number of averages when averaging is turned on.
- Graticule area** The Graticule area is also referred to as the waveform viewing area. This is where all the waveform data and markers are displayed on the screen.
- Time Base area** The Time Base area lists the time base scale setting, reference location, and position setting. The reference location is indicated by an arrow. In Figure 1-2, the time base settings are:
- Scale ..... 5.0 ns/div
  - Reference location ..... set to the left of the graticule area
  - Position ..... 20 ns
- Channel Settings and Measurement Results area** Channel Settings and Measurement Results share the same area. Channel Settings are displayed only when the measurements are off. When making an automatic measurement, the results are displayed in place of the channel settings.
- To display the Channel Settings, press:
- (Shift) Clr Meas**
- When a channel number is displayed, it indicates the channel is turned on. In Figure 1-2, the channel settings are:
- Channel 1, on
    - Scale ..... 75 mV/div
    - Offset ..... -10 mV
  - Channel 2, on
    - Scale ..... 60 mV/div
    - Offset ..... 0 mV
  - Channels 3 and 4, off
- Marker Results and Statistics Results area** Marker Results and Statistics Results share the same area. Statistics Results are displayed only when the manual and waveform markers are turned off, or when the measurement marker readout is turned off.

<b>Histogram, Limit Test and Mask Test</b>	The entire area below the timebase area is used by the Histogram, Limit Test and Mask Test features while in their respective menus.
<b>Softkey menu area</b>	Softkey menus are displayed in this area. The menu that is displayed depends on which key is pressed. The <i>Agilent 83480A, 54750A Quick Start Guide</i> contains an explanation of how the softkeys operate.
<b>Memory bar</b>	The memory bar represents the entire waveform record. The highlighted part of the memory bar represents the portion of the waveform record currently on the display. When possible, the acquisition hardware is set up so all of the waveform record is displayed on the screen. When the acquisition is stopped and the waveform is magnified with the time base controls, the memory bar indicates which portion of the waveform is viewed.

---

## Entry devices

The entry devices are:

- the knob
- the arrow keys
- the keypad

You can use the entry devices to change the numeric settings of some softkeys, such as trigger level, or to select an item from a list of choices.

When using the entry devices to scroll through a list of choices, you may notice the background color of each item change as you scroll through the list. Occasionally, a particular feature may not be available. In this case, the background color of that feature will *not* change as you scroll through the list.

---

## Indicator lights

There are three indicator lights near the top-left corner of the instrument. These lights give you a quick indication of the acquisition status of the instrument.

### **Armed**

When the armed light is on, it indicates the trigger circuit is armed and waiting for a valid trigger event to occur. A valid trigger event occurs when a signal meets the triggering conditions specified in the trigger menu.

### **Triggered**

When the triggered light is on, it indicates the instrument accepted a trigger event. Every time the instrument accepts a trigger event, one data point is sampled. When enough points have been sampled to fill the record length, a trace is completed.

The triggered light can be used to help determine the trigger thresholds. To do this, simply move the trigger level in either direction. When the triggered light turns off, you know that is one of the trigger thresholds. Move the trigger level in the other direction to determine the other threshold. You now know what the trigger thresholds are and you can set the trigger level as required by your application.

Typically the trigger level is set halfway between the two thresholds.

### **Freerun**

Freerun automatically provides a trigger as soon as the trigger is armed. It is used to view the input signal when no valid triggers are available.

*Agilent 83480A Option 100 only:* When in the 12 GHz mode, the triggered and freerun lights are illuminated at all times to reflect the operation of the 12 GHz trigger.

# The Rear Panel

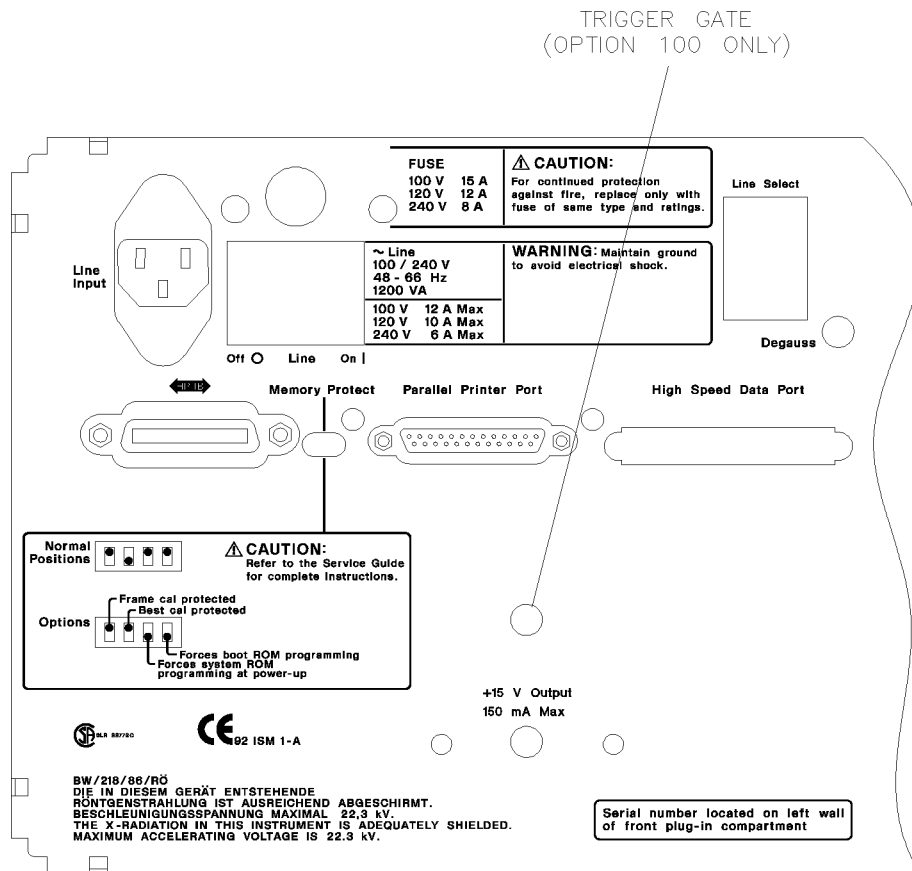

54754e23

Figure 1-3. The instrument rear panel.

**The Rear Panel**

**Line Input** The Line Input is the input for the line power source. Make sure the line-power source outlet has a protective ground contact.

**Line On/Off** The Line switch turns the instrument on and off. After applying power, allow the temperature of the instrument to stabilize for best measurement results.

**NOTE**  
The instrument continues to draw power when it is plugged into the ac power source, even if the line power switch is off.

**Fuse** The power input fuse is located behind a small removable metal plate. Depending on the voltage of the line power, the line-power fuse can be replaced with one of the following values:

- 100V operation: F15A, 250V ..... Agilent part number 2110-0054
- 120V operation: F12A, 250V ..... Agilent part number 2110-0249
- 240V operation: F8A, 250V ..... Agilent part number 2110-0342

**Line Select** The Line Select switch adapts the instrument to the power source. Select either 115 V or 230 V, whichever most closely matches the voltage being supplied to the Line Input. To change Line Select, remove the black plastic insert, rotate clockwise 180°, and reinsert it.

---

**CAUTION** Before switching on this instrument, make sure that the line voltage selector switch is set to the voltage of the power supply and the correct fuse is installed. Assure the supply voltage is in the specified range.

---

**GPIB** The GPIB connector allows an external computer to communicate with the instrument.



<b>Parallel Printer Port</b>	The Parallel Printer Port allows the instrument to communicate with remote printers or plotters.	
<b>High Speed Data Port</b>	Not used.	
<b>Degauss</b>	Activates a CRT screen degaussing.	
<b>+15 V, 150 mA output</b>	The +15 V, 150 mA output provides power for external modules, such as the Agilent 54118A 18 GHz trigger.	
<b>Opt 100 Trigger Gate</b>	This TTL compatible input allows gating of the 12 GHz trigger. Refer to “2-12 GHz mode ( <i>Option 100 only</i> )” in Chapter 13 for additional information.	
<b>Memory Protect</b>	Frame Cal protected	Up position prevents timebase calibration from being overwritten; switch to down position to perform mainframe calibration.
	Best cal protected	Not used.
	Forces system ROM programming at power-up	In down position, the operating system will be loaded from the disk in the disk drive at power-up (approximately 7 minutes).
	Forces boot ROM programming	Leave in up position (factory use only).

**The Instrument at a Glance**



**General Purpose Keys**

---

## General Purpose Keys

**What you'll find in this chapter**

The front panel includes the following functions:

- the Clear Display key
- the Fine function
- the Help key
- the Local key
- the Run key
- the Stop/Single key

This chapter describes each of these functions. They are listed alphabetically.

---

## The Clear Display Key

The Clear Display key erases all channel and function waveform data from the graticule area, and resets all associated measurements and measurement statistics.

- 
- |                                       |   |
|---------------------------------------|---|
| <b>When the instrument is stopped</b> | If the instrument is stopped, the display remains cleared of waveform data until the trigger circuit is rearmed and the instrument is triggered. Then, the new data is displayed and measurements are recalculated. |
| <b>When the instrument is running</b> | If the instrument is running, new waveform data is displayed on the next acquisition and all measurements are recalculated.   |

---

## The **Fine** Function

The Fine function increases the resolution of the knob used to adjust the channel scale, offset, and time base scale. For example, on most plug-ins the knob changes the channel scale in a 1-2-5 sequence, such as 10 mV, 20 mV, and 50 mV.

When the Fine function is selected, the knob changes the channel scale in smaller increments, such as 10.0 mV, 10.1 mV, 10.2 mV.

To put the instrument in the Fine mode, press:

**(Shift) Fine**

Repeat the process to exit the Fine mode.

The screen displays the word **FINE** at the top-right corner of the graticule area when the Fine mode is active.

# The Help Key

The Help key assists you in finding the key sequence used to execute a particular feature. When Help is pressed, a three-column index is displayed on the screen.

The left column lists the features of the instrument.

The middle column lists the hardkeys.

The right column lists the softkeys.

Use either the knob or arrow keys to scroll through the list of features.

Feature	Hardkey	Softkey	Help
Cancel print	SHIFT Setup		
Centronics printer selection	SHIFT Print	Destination	
Channel autoscale	Channel	Autoscale	
Channel BW limit	Channel	Bandwidth	
Channel BW limit	Channel	Optical (83485)	
Channel calibration status	Channel	Calibrate...	
Channel display	Channel	Display	
Channel filter	Channel	Optical (83485)	
Channel optical cal	Channel	Calibrate...	
Channel skew adjustment	Channel	Calibrate...	
Channel vertical cal	Utility	Calibrate...	
Channel vertical position	Channel	Offset	
<b>Channel vertical scale</b>	<b>Channel</b>	<b>Scale</b>	<b>Line</b> <b>Channel</b>
Channel vertical units	Channel	External scale	
Channel view	Channel	Display	
Channel wavelength	Channel	Optical (83485)	
Channel, magnify	Math	Define function	
Clear measurements from screen	SHIFT Clr		
Clear non-volatile memory	Utility	System config	
Clear stored pixel memory	Waveform	Clear memory	
Clear waveforms (from display)	Clear display		
Color grade measurement window	Define meas	Eye window	
Color grade refresh rate	Display	Refresh rate	
Color grade signal type	Define meas	Color grade sig	<b>Exit</b>
Color graded display	Display	Color grade	

Figure 2-1. The Help menu.

For example, to move a signal vertically on the display, look up Channel vertical scale in the Help menu list. The middle column instructs you to press the Channel key, and the right column instructs you to press the Scale key.

Features may be listed under different names. For example, you could have also looked for scale, vertical or vertical scale. Each of these titles give you the same key sequence to follow.

---

## The Local Key

To access the Local function, press:

**Shift** **Local**

The Local function returns control of the instrument to the front panel. This is the only key that is active when the instrument is under remote control. The exception occurs when the controller sends a Local Lockout command. The Local Lockout command disables the Local function key.



---

## The Run Key

The Run key causes the instrument to resume acquiring data. If the instrument is stopped, it starts acquiring data on the next trigger event. If the instrument is already in the Run mode, it continues to acquire data on successive trigger events.

If pressing the Run key does not cause waveform data to display on the screen, try the following:

- Press the Autoscale key.
- Make sure a signal is connected to one of the channels and the display for that channel is turned on.
- Make sure the offset does not have the trace clipped off the display.
- Check the trigger setup conditions to make sure the trigger conditions are valid for the signal.
- Set the Trigger Sweep mode to Freerun. Freerun forces the instrument to trigger, which may allow you to see enough of the signal so that you can set up the front panel properly.

---

## The Stop/Single Key

Pressing the Stop/Single key causes the instrument to stop acquiring data. The status area of the screen displays the message:

**Acquisition is stopped.**

Each subsequent press of the Stop/Single key rearms the trigger circuit. A complete acquisition cycle is performed, any measurements are recalculated, and the status area of the screen displays the message:

**Acquisition is complete.**

If all of the channels are turned off or if a trigger event is not found, the instrument will not acquire any data.

**Specifications and  
Characteristics**

---

## Specifications and Characteristics

### **What you'll find in this chapter**

This chapter lists specifications and characteristics for the Agilent 83480A digital communications analyzer and the Agilent 54750A digitizing oscilloscope. Specifications apply over the temperature range +15°C to +35°C (unless otherwise noted) after the instrument's temperature has been stabilized after 60 minutes of continuous operation.

### **Specifications**

*Specifications* described warranted performance.

### **Characteristics**

*Characteristics* provide useful, nonwarranted information about the functions and performance of the instrument. *Characteristics are printed in italics.*

### **Calibration Cycle**

Agilent Technologies warrants instrument specifications over the recommended calibration interval. To maintain specifications, periodic recalibrations are necessary. We recommend that the Agilent 83480A be calibrated at an Agilent Technologies service facility every 24 months.

Additional specifications and characteristics are included in the user's guides for the individual plug-in modules.

---

## Horizontal System

<b>Scale factor</b>	Full scale is ten divisions. Minimum ..... 10 ps/div Maximum ..... 1 s/div
<b>Delay</b>	Time offset relative to trigger. Minimum ..... 22 ns Maximum ..... 1000 screen diameters or 10 s, whichever is smaller
<b>Time interval accuracy</b>	$\leq 8 \text{ ps} \pm 0.1\%$ of reading (dual marker measurement)
<b>Time interval resolution</b>	(screen diameter)/(record length) or 62.5 fs, whichever is larger
<b>Time display resolution</b>	451 points horizontally

---

## Trigger Specifications Electrical and Optical Channels

---

---

### Standard instrument, 2.5 GHz mode

<b>Trigger bandwidth</b>	dc – 2.5 GHz
<b>Sensitivity</b>	40 mV p-p at 100 MHz, increasing linearly to 200 mV p-p at 2.5 GHz.
<b>Pulse width</b>	200 ps >200 mV
<b>Bandwidth limit</b>	Trigger bandwidth reduced to approximately 100 MHz with bandwidth limit enabled.
<b>Maximum trigger signal</b>	$\pm 2$ Vdc + ac peak (+16 dBm)
<b>Jitter</b>	$\leq 2.5$ ps rms + $5E-5 \times$ delay setting (at 2.5 GHz with 200 mV source).

### Option 100, 12 GHz mode

For more information on Option 100 triggering, refer to Chapter 13.

<b>Trigger bandwidth</b>	2.0 GHz – 12 GHz ( <i>1 GHz to 15 GHz typical</i> )
<b>Sensitivity</b>	200 mV p-p from 2.0 GHz to 12 GHz (sine wave input)
<b>Maximum trigger signal</b>	$\pm 2$ Vdc + ac peak (+16 dBm)
<b>Jitter</b>	< 2 ps rms with time delay less than 100 ns

### Option 100, 12 GHz/Gate mode

For more information on Option 100 triggering, refer to Chapter 13.

<b>Trigger bandwidth</b>	<i>2.0 GHz – 12 GHz (typical)</i>
<b>Sensitivity</b>	<i>300 mV p-p from 2.0 GHz to 12 GHz (sine wave input) (typical)</i>
<b>Trigger gating levels (characteristic)</b>	Standard TTL: Disable ..... <0.8 V Enable ..... >2.0 V Maximum allowable range ..... 0.0 V–5.0 V <1 MHz gating rate input impedance ..... high (~10 k $\Omega$ )

---

## General Specifications

<b>Use</b>	Indoor
<b>Temperature</b>	Operating ..... 15°C to +35°C (59°F to +95°F) Non-operating ..... -40°C to +70°C (-40°F to +158°F)

### Humidity

**NOTE**

This test requires a one hour warm-up period.

Operating ..... up to 95% humidity (non-condensing) at +35 °C (+95 °F)  
Non-operating ..... up to 90% relative humidity at +65 °C (+149 °F)

<b>Altitude</b>	Operating ..... up to 4,600 meters (15,000 ft) Non-operating ..... up to 15,300 meters (50,000 ft)
-----------------	---

<b>Vibration</b>	Operating Random vibration 5–500 Hz, 10 minutes per axis, 0.3 g <sub>rms</sub> Non-operating Random vibration 5–500 Hz, 10 minutes per axis, 2.41 g <sub>rms</sub> ; Resonant search, 5 to 500 Hz swept sine, 1 octave/minute sweep rate, 0.75g, 5 minute resonant dwell at 4 resonances per axis.
------------------	---



## Specifications and Characteristics

<b>Power Requirements</b>	Voltage .....	90 to 132 or 198 to 264 Vac, 48-66 Hz
	Power .....	1200 VA; 650 W
<b>Weight (approximate)</b>	Net .....	24.5 kg (54 lb)
	Shipping .....	31.8 kg (70 lb)
<b>Dimensions</b>	H × W × D	238.2 mm × 433.6 mm × 637.38 mm (9.378 in × 17.071 in × 25.094 in)

## Specifications and Characteristics



**Calibration Overview**

---

## Calibration Overview

This chapter describes the calibration of the mainframe and the plug-in modules. It is intended to give you, or the calibration laboratory personnel, an understanding of the various calibration procedures available, and how they were intended to be used. There is a description of the calibration menu included in the manuals provided with the plug-in modules and probes.

Proper calibration is critical to measurement accuracy and repeatability. The Agilent 54750A/83480A and their associated modules and accessories require that both factory and user calibrations be implemented at the recommended intervals in order to perform measurements at their published specifications.

This chapter is divided into three sections. The first section describes factory calibrations. A factory calibration consists of verifying instrument performance to all specifications. If an instrument fails to meet specifications, adjustment or repair may be necessary. For most users, this will mean shipping the instrument back to an authorized service center. Some users may purchase the required instrumentation and perform the factory timebase calibrations themselves using the optional *Agilent 83480A, 54750A Service Guide*.

The second part of the chapter addresses calibrations that are routinely performed by the end user. Subsections in each of the two main sections discuss the individual calibrations. In addition, there will be summary tables at the end of each of these sections summarizing the main areas addressed. A complete calibration summary table is included at the end of the chapter. Both factory and user calibrations must be performed regularly in order to ensure proper measurement accuracy and repeatability.

---

**CAUTION**

The input circuits can be damaged by electrostatic discharge (ESD). Avoid applying static discharges to the front-panel input connectors. Before connecting a coaxial cable to the connectors, momentarily short the center and outer connectors of the cable together. Avoid touching the front panel input connectors without first touching the frame of the instrument. Be sure that the instrument is properly earth-grounded to prevent buildup of static charge. It is strongly recommended that an antistatic mat and wristband be used when connecting to electrical channel inputs, particularly TDR inputs.

---

<b>Calibration interval</b>	Agilent Technologies recommends that the factory calibration be performed on a periodic basis. Agilent Technologies designs instruments to meet specifications over the recommended calibration interval provided that the instrument is operated within the specified operating environment. To maintain specifications, periodic recalibrations are necessary. We recommend that the plug-in module be calibrated at an Agilent Technologies service facility every 12 months. Users are encouraged to adjust the calibration cycle based on their particular operating environment or measurement accuracy needs.
<b>Required warm-up time</b>	The instrument requires a 1 hour warm-up period before any of the calibrations mentioned in this chapter are performed. It is not enough for the instrument to be in the standby setting. It must be turned on and running for the entire hour.
<b>Remote operation</b>	Remote programming commands for calibrations are included in the Agilent 83480A/Agilent 54750A Programming's Guide. Performing calibrations remotely is slightly different than the operation of front-panel calibrations.
<b>Contents</b>	Factory Calibrations on page 4-4 User Calibrations—Optical and Electrical on page 4-7 Complete Calibration Summary on page 4-20

---

# Factory Calibrations

The following calibrations are performed at the factory:

- Mainframe Calibration
- O/E Factory Wavelength Calibration

**Table 4-1. Factory Calibration Summary**

Calibration	What is calibrated	Measurements Affected	Recommended Interval	Softkey Path
Mainframe Calibration	Accuracy and continuity of the timescale	Channels affected: optical & electrical. All time base measurements such as rise time, fall time, eye width, and jitter.	Annually at Agilent Technologies service center or if operating temp has changed and remains 5°C or more from calibration temperature. See service manual.	<b>Utility</b> <b>Calibrate</b> <b>Calibrate frame</b>
O/E Factory Wavelength Calibration	The photodetector responsivity	Channels affected: optical. Amplitude accuracy of all optical channel measurements. Optical power meter accuracy.	Annual factory re-calibration of standard wavelengths.	Not user accessible. <sup>1</sup>

<sup>1</sup> Refer to "O/E User-Wavelength Calibration" in this chapter.

---

## Mainframe Calibration

Mainframe calibration affects both optical and electrical measurements. Mainframe calibration improves timebase accuracy. All timebase measurements such as rise time, fall time, eye width, jitter, and so forth are affected by the timebase accuracy.

The calibration factors are stored in the nonvolatile RAM of the instrument. There is a switch on the back panel of the instrument that allows the mainframe calibration to be protected or unprotected. Next to the switch there is a drawing that shows each switch's function and protected position. Refer to the optional *Agilent 83480A, 54750A Service Guide* for more details about the mainframe calibration, and the position of the rear-panel memory protect switches.

---

**CAUTION**

---

To prevent access to the mainframe calibration switch, place a sticker over the access hole to this switch.

---

**CAUTION**

---

Do not attempt a Mainframe calibration without consulting the *Agilent 83480A, 54750A Service Guide*.

A mainframe calibration should be performed on a periodic basis, annually, or when the ambient operating has changed by and remains 5°C different than the operating temperature at which the last mainframe calibration was performed. To see how much the operating temperature has changed since the last mainframe calibration and the date of the last mainframe calibration, check the Calibration status by pressing the following key sequence: **Utility**, **Calibrate**, and then **Cal status on**.

The temperature change is displayed at the top of the display as shown in the following figure.

**Factory Calibrations**

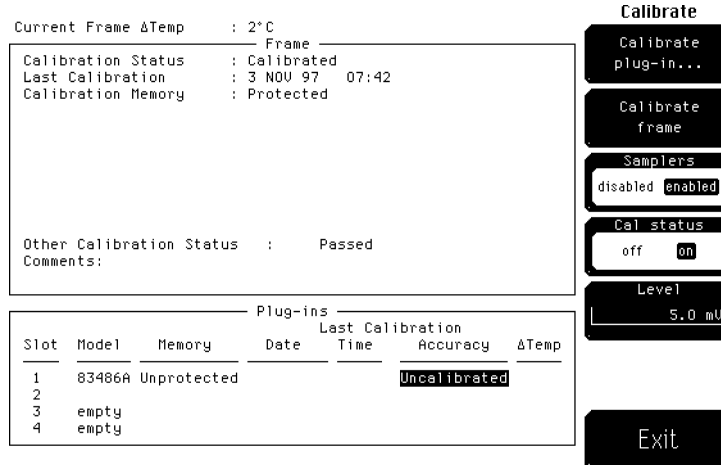

**Figure 4-1. Current Frame ΔTemp condition**

If the **Current Frame ΔTemp** listing is greater than  $\pm 5^{\circ}\text{C}$ , then the mainframe should either be calibrated at the current operating temperature or be placed in an ambient air temperature that is within  $5^{\circ}\text{C}$  of the temperature of the current calibration.

---

## O/E Factory Wavelength Calibration

Optical/electrical (O/E) factory wavelength calibration, compensates for the photodetector responsivity. The accuracy of all optical channel measurements is dependent on proper O/E calibration. O/E calibrations should be performed annually. Most customers return their optical plug-ins to an authorized Agilent Technologies service center for this calibration at the same time they are having their mainframes re-calibrated.

The Agilent 83480-series optical modules have one or two standard wavelengths (850 nm or 1310/1550 nm). The O/E Calibration function allows you to calibrate the instrument for use at one additional user-defined wavelength. This calibration does not affect the factory calibrations. See



the following section on User Calibrations for additional information on this procedure.

---

## User Calibrations—Optical and Electrical

The following calibrations can be performed by the user:

- O/E User Wavelength Calibration
- Plug-in Module Vertical Calibration
- Offset Zero Calibration
- Dark Calibration
- Probe Calibration
- Channel Skew
- External Scale

Electrical channels have calibration procedures for:

- adjusting timebase skew, for matching propagation delay between channels, probes, cables, and so forth
- using external probes

Optical channels have calibration procedures for:

- adjusting timebase skew
- monitoring and adjusting internal offsets
- performing a user-defined O/E responsivity adjustment

---

### CAUTION

The input circuits can be damaged by electrostatic discharge (ESD). Avoid applying static discharges to the front panel input connectors. Before connecting a coaxial cable to the connectors, momentarily short the center and outer connectors of the cable together. Avoid touching the front panel input connectors without first touching the frame of the instrument. Be sure the instrument is properly earth-grounded to prevent buildup of static charge. An antistatic mat and wristband are strongly recommended, particularly when working with TDR modules.

---

**User Calibrations—Optical and Electrical**

**Table 4-2. Optical and Electrical Channel User Calibration Summary**

Calibration	What is calibrated	Measurements Affected	Recommended Interval	Key Path
O/E User Wavelength Calibration	The photodetector responsivity	Channels affected: optical. All optical channel measurements at user wavelengths.	Annual re-calibration of user defined non-factory wavelengths	<b>Optical Channel Setup</b> Calibrate O/E Cal
Plug-in Vertical Calibration	Vertical offset and vertical scale accuracy for both electrical and optical channels.	Channels affected: optical & electrical. Any optical or electrical vertical measurements such as $V_p$ to $p$ , eye height, extinction ratio, and the optical power meter	Perform after any power cycle or once every 10 hours during continuous use or if operating temperature changes by more than 2°C.	<b>Utility</b> Calibrate Calibrate Plug-in
Offset Zero Calibration	Vertical offset is calibrated for the optical channel only. This calibration doesn't include vertical scale accuracy.	Channels affected: optical. Any optical vertical measurements including: $V_p$ to $p$ , eye height, and extinction ratio.	Perform a plug-in vertical calibration in order to meet published specifications. Because the offset zero calibration performs only the offset portion of the plug-in vertical calibration, it should only be used before fast non-critical measurements.	<b>Optical Channel Setup</b> Calibrate Offset 0
Dark Calibration	Dark calibration measures the channel offset signal without any light present and this value is used in the extinction ratio algorithm.	Channels affected: optical & electrical. Extinction ratio.	Before extinction ratio measurements if the vertical scale or offset has changed since the last dark calibration or after a plug-in vertical calibration is performed.	<b>Shift</b> , <b>Meas eye</b> Extinction ratio Dark Cal

**User Calibrations—Optical and Electrical**

**Table 4-3. Miscellaneous User Calibration Summary**

Calibration	What is calibrated	Measurements Affected	Recommended Interval	Key Path
Probe calibration	Probe Attenuation	Channels affected: electrical. Any electrical measurement taken with the probe	Whenever a probe is connected	<b>Electrical Channel Setup</b> Calibrate Calibrate probe
Channel Skew	Calibrates out the small differences in delay between channels. Useful for looking at timing differences between channels	Channels affected: optical & electrical. Multiple channel measurements, such as Differential TDR	Before multiple channel measurements when measuring timing differences between channels.	<b>Channel Setup</b> Calibrate Skew
External Scale	Compensates for gain or loss associated with external devices (calibrates vertical scale to external device)	Channels affected: optical & electrical. Any measurement taken through an external device (component or transducer)	Whenever using external devices (component or transducer)	<b>Channel Setup</b> External Scale

---

## O/E User-Wavelength Calibration

This optional optical/electrical (O/E) calibration is for optical measurements only. It compensates for the photodetector's responsivity. The vertical accuracy of all optical channel user wavelength measurements is dependent on proper O/E user wavelength calibration. O/E user-wavelength calibrations should be performed annually or whenever a new wavelength is being measured. To perform a O/E user-wavelength calibration, a CW optical source with a known optical output power level is required. Refer to the specifications for the plug-in module for the acceptable power level ranges.

**NOTE**

The optical channel calibration accuracy is heavily dependent on the accuracy to which you know the optical source power. For best results, measure the optical source power with an optical power meter such as the Agilent 8153A and use precision optical connectors. In addition, proper connector cleaning procedures are essential to obtaining an accurate calibration.

**To perform an O/E user-wavelength calibration**

1. Press the plug-in module's front-panel optical channel **SETUP** key.
2. Press **Calibrate**, and then **O/E cal**.
3. Input the correct wavelength, and follow the instructions on the screen.

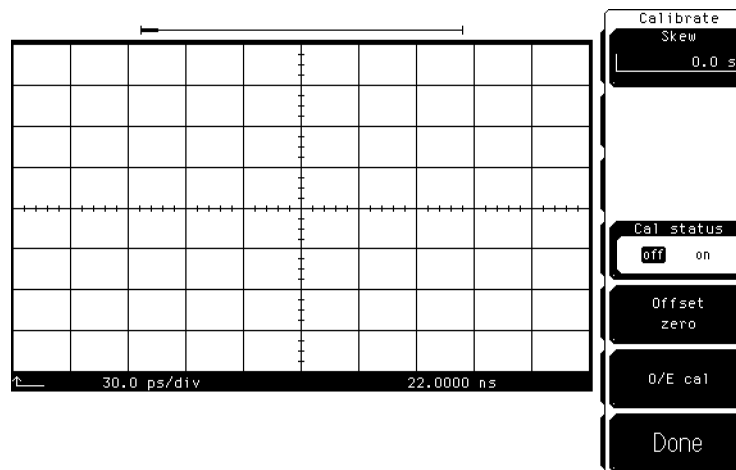

**Figure 4-2. Plug-in calibration menu**

## User Calibrations—Optical and Electrical

### To use an O/E user-wavelength calibration

1. Press the plug-in module's front-panel optical channel **SETUP** key.
2. Press **Bandwidth/wavelength** and then **Wavelength**.
3. Press **Usr** *wavelength* and then **Enter**.

---

## Plug-in Module Vertical Calibration

The plug-in module vertical calibration is for both optical and electrical measurements. It allows the instrument to establish the calibration factors for a specific plug-in when the plug-in is installed in the mainframe. The plug-in calibration factors are valid only for the specific mainframe slot in which it was calibrated. The plug-in vertical calibration establishes vertical accuracy.

A plug-in vertical calibration should be done if:

- The mainframe has cycled power.
- The plug-in has been repaired, reprogrammed, or removed from the mainframe.
- The instrument's operating temperature has changed and remains more than 5°C from the temperature at which the Plug-in calibration was performed.

To obtain the best measurement results, it is recommended that a user vertical calibration be performed after every 10 hours of continuous use or if the temperature has changed by greater than 2°C from the previous vertical calibration.

### To view the temperature change

This procedure displays the temperature change that the instrument has undergone since the last Plug-in Vertical Calibration.

1. Press the front-panel channel **SETUP** key.
2. Press **Calibrate** and then **Cal status** on.

The current plug-in  $\Delta$ Temp value is listed for each installed module.

**To perform a plug-in module vertical calibration**

1. Remove any front-panel connections from electrical channels.
2. Cover the optical inputs for the optical channels.
3. Press **Utility**, **Calibrate . . .**, and then **Calibrate plug-in . . .**.
4. Select the plug-in module to be calibrated, press **1 and 2** or **3 and 4**.
5. Press **Start cal** to start the calibration.
6. Follow the on-screen instructions.

No additional equipment is required to perform a plug-in vertical calibration. Reference signals are both generated and routed internally, for the optical and electrical channels. If you are prompted to connect the calibrator output to the electrical channel during an optical vertical calibration, then the factory O/E calibration has been lost. The module must then be returned to Agilent Technologies for calibration.

---

## Offset Zero Calibration

The offset zero calibration performs a quick offset calibration on the optical channel for optical measurements. Since the primary source of calibration error on the optical channel is offset drift, this function is useful between the plug-in module vertical calibrations if the plug-in module has not been removed or reinstalled and the operating temperature has not changed more than  $\pm 5^{\circ}\text{C}$ . In order to ensure that instrument specifications are met, perform the plug-in vertical calibration.

Performing an offset zero calibration is much faster than performing a complete vertical calibration. For critical measurements where offset measurement uncertainty is important to consider, perform an offset zero calibration between module vertical calibrations. Perform an offset zero calibration if the vertical scale or offset changes.

**User Calibrations—Optical and Electrical**

**To initiate an offset calibration**

1. Disconnect all inputs from the module being calibrated.
2. Cover all optical inputs.
3. Press the plug-in module's front-panel optical channel **SETUP** key.
4. Press **Calibrate** and then **Offset zero**.

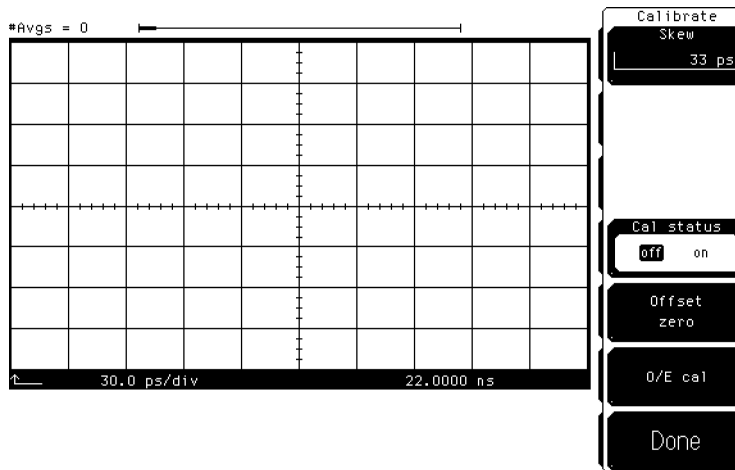

**Figure 4-3. Offset Zero Calibration**



---

## Dark Calibration

The dark calibration is for optical measurements, or electrical measurements if an external O/E is being used. This calibration measures the optical channel offset signal when there isn't any light present and then uses this information in performing extinction ratio measurements. Dark calibrations should be done for the following conditions:

- Before any critical extinction ratio measurements are made
- After a plug-in vertical calibration
- If a module has been removed
- If the mainframe power has been cycled
- If extinction ratio measurements are being made after the vertical scale or the offset has changed.

If the line power has been cycled, the dark calibration invokes either the offset zero calibration or plug-in vertical calibration as needed. This increases the time required for the dark calibration to complete. The **Dark cal** softkey is located within the Extinction ratio menu.

### To initiate a dark calibration

1. Press the **Display** key. Press the **Color grade** softkey, and set its setting to **on**.

Color grade must be enabled to perform an extinction ratio measurement and a dark calibration. In addition, the dark level (amplitude when there is no signal present) must be on the screen to perform a dark calibration.

2. Press the blue shift key, and then the **Meas eye** softkey which is located beneath the display.
3. Press **Extinction ratio ...** and then **Dark cal**.

Disconnect all inputs from the module, including the trigger signal, and block any ambient light from the photodetector with a connector plug. Follow the instructions on the screen.

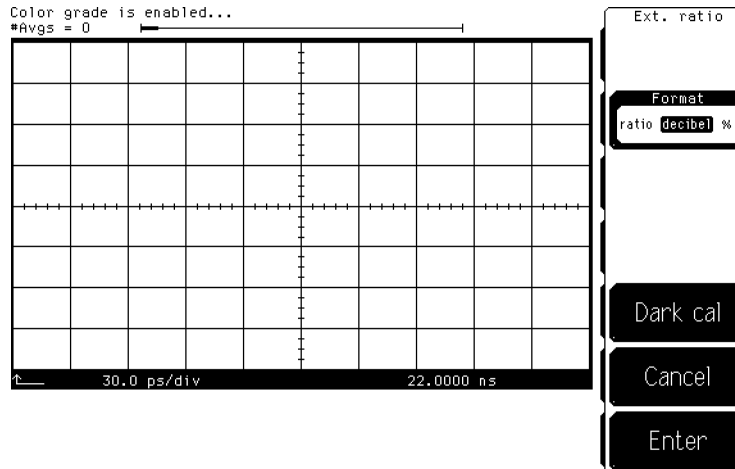
**User Calibrations—Optical and Electrical****Figure 4-4. Dark calibration menu**

---

## Channel Skew Calibration

This calibration affects both optical and electrical measurements. The skew calibration changes the horizontal position of a waveform on the display. The skew calibration has a range of approximately 100  $\mu$ s. You can use skew to compensate for the differences in cable or probe lengths. It also allows you to place the trigger edge at the center of the display when you are using a power splitter connected between the channel and trigger inputs. Another use for skew is when you are comparing two waveforms that have a timing difference. If you are interested in comparing the shapes of two waveforms rather than the actual timing difference, you can use skew to overlay one waveform on top of the other waveform.

- To skew two channels**
1. Turn both channels on and overlay the signals vertically.
  2. Expand the time base so that the rising edges are at about a 45° angle.
  3. Press the plug-in module's front-panel channel **SETUP** key.
  4. Press **Calibrate** and then **Skew**.
  5. Adjust the skew on one of the channels so that the rising edges overlap at the 50% points.

---

## Probe Calibration

Probe calibration applies to electrical measurements only. For active probes such as the Agilent 54701A, which the instrument can identify through the probe power connector, the instrument automatically adjusts the channel vertical scale factors to the probe's nominal attenuation, even if a probe calibration is not performed.

For passive probes or non-identified probes, the instrument adjusts the vertical scale factors only if a probe calibration is performed. Probe calibration allows the instrument to establish the gain and offset of specific probes that are connected to a channel of the instrument, and then apply those factors to the calibration of that channel.

The analyzer calibrates to the tip of the probe by setting the probe attenuation to the actual attenuation ratio of the probe. The CAL signal is internally routed to the probe tip for Agilent Technologies active probes.

The mainframe's CAL signal is a voltage source, therefore you can let the instrument compensate for the actual characteristics of your probe by letting the instrument calibrate to the tip of the probe. The instrument automatically calibrates to the tip of the probe, sets the probe attenuation, and compensates for any probe offset.

If you do not perform a probe calibration but want to use a passive probe, enter the attenuation factor using the following steps:

1. Press the plug-in module's front-panel channel **SETUP** key.

**User Calibrations—Optical and Electrical**

2. Press **External scale** and then **Attenuation**.

You can use the probe calibration to calibrate any network, including probes or cable assemblies. The instrument calibrates the voltage at the tip of the probe or the cable input.

**To calibrate an Agilent identifiable probe**

1. Press the plug-in module's front-panel-channel **SETUP** key.
2. Press **Calibrate** and then **Calibrate Probe**.

**To calibrate a non-identifiable probe**

1. Connect the voltage probe to the plug-in.
2. Attach the probe tip to the CAL hook that is located near the floppy disk drive.
3. Press the plug-in module's front-panel channel **SETUP** key.
4. Press **Calibrate** and then **Calibrate probe**.

If the probe being calibrated has an attenuation factor that allows the instrument to adjust the gain (in hardware) to produce even steps in the vertical scale factors, the instrument will do so. Typically, probes have standard attenuation factors such as divide by 10, divide by 20, or divide by 100.

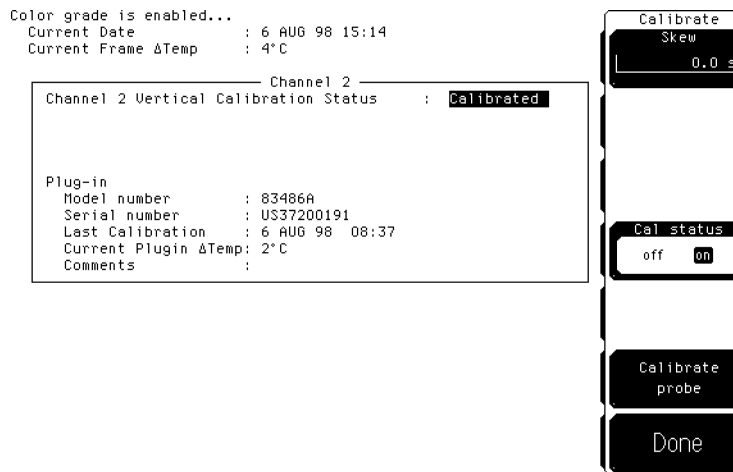

**Figure 4-5. Electrical Channel Calibrate Menu**

**To calibrate other devices**

The information in this section applies to both optical and electrical measurements. Since the mainframe's CAL signal is a voltage source, it cannot be used to calibrate to the probe tip when the units are set to Ampere, Watt, or Unknown. Instead, set the external gain and external offset to compensate for the actual characteristics of the probe or device. If you do not know the actual characteristics, you can refer to the typical specifications that came with the probe or device.

1. Press the plug-in module's front-panel channel **SETUP** key.
2. Press **External scale**.
3. Press **Atten units** Ratio, **Attenuation** 1:1, and then **Units** Ampere (Volt, Watt, or Unknown).
4. Press **Ext gain**, and enter the actual gain characteristics of the probe or device.
5. Press **Ext offset**, and enter the offset introduced by the probe or device.

---

## External Scale

Both optical and electrical channels have an External scale setting which allows the user to enter in an offset value to compensate for gains or losses not associated with the device under test. This feature is useful for adjusting out the effects of devices such as test fixtures and attenuators so that the reading on the display gives the measurement value associated with only the actual device under test.

**To adjust the external scale**

1. Press the plug-in module's front-panel channel **SETUP** key.
2. Press **External scale**, and set the **Atten units** to "decibel".
3. Press **Attenuation**, and enter the appropriate values.

### User Calibrations—Optical and Electrical

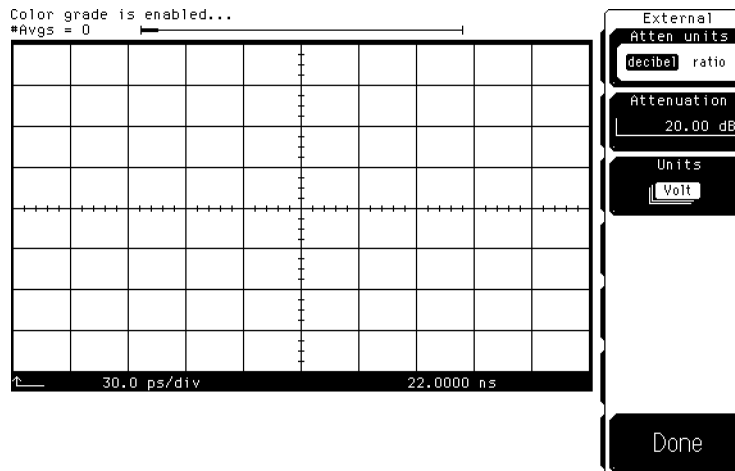

Figure 4-6. External Scale Menu

# Complete Calibration Summary

**Table 4-4. Complete Calibration Summary**

Calibration	What is calibrated	Measurements Affected	Recommended Interval	Key Path
Mainframe Calibration	Accuracy and continuity of the timescale	Channels affected: optical & electrical. All time base measurements such as rise time, fall time, eye width, and jitter.	Annually at Agilent Technologies service center or if operating temp has changed and remains 5°C or more from calibration temperature. See service manual.	<b>Utility</b> <b>Calibrate</b> <b>Calibrate frame</b>
O/E Factory Wavelength Calibration	The photodetector responsivity	Channels affected: optical. Amplitude accuracy of all optical channel measurements. Optical power meter accuracy	Annual factory re-calibration of standard wavelengths.	Not user accessible. <sup>1</sup>
O/E User Wavelength Calibration	The photodetector responsivity	Channels affected: optical. All optical channel measurements at user wavelengths.	Annual re-calibration of user defined non-factory wavelengths	<b>Optical Channel Setup</b> <b>Calibrate</b> <b>O/E Cal</b>
Plug-in Vertical Calibration	Vertical offset and vertical scale accuracy for both electrical and optical channels.	Channels affected: optical & electrical. Any optical or electrical vertical measurements such as $V_p$ to $p$ , eye height, extinction ratio, and the optical power meter	Perform after any power cycle or once every 10 hours during continuous use or if operating temperature changes by more than 2°C.	<b>Utility</b> <b>Calibrate</b> <b>Calibrate Plug-in</b>

<sup>1</sup> Refer to "O/E User-Wavelength Calibration" in this chapter.

**Complete Calibration Summary**

**Table 4-4. Complete Calibration Summary (continued)**

Calibration	What is calibrated	Measurements Affected	Recommended Interval	Key Path
Offset Zero Calibration	Vertical offset is calibrated for the optical channel only. This calibration doesn't include vertical scale accuracy.	Channels affected: optical. Any optical vertical measurements including: $V_p$ to $p$ , eye height, and extinction ratio.	Perform a plug-in vertical calibration in order to meet published specifications. Because the offset zero calibration performs only the offset portion of the plug-in vertical calibration, it should only be used before fast non-critical measurements.	<b>Optical Channel Setup</b> Calibrate Offset 0
Dark Calibration	Dark calibration measures the channel offset signal without any light present and this value is used in the extinction ratio algorithm.	Channels affected: optical & electrical. Extinction ratio.	Before extinction ratio measurements if the vertical scale or offset has changed since the last dark calibration or after a plug-in vertical calibration is performed.	<b>Shift</b> , <b>Meas eye</b> Extinction ratio Dark Cal
Probe calibration	Probe Attenuation	Channels affected: electrical. Any electrical measurement taken with the probe	Whenever a probe is connected	<b>Electrical Channel Setup</b> Calibrate Calibrate probe
Channel Skew	Calibrates out the small differences in delay between channels. Useful for looking at timing differences between channels	Channels affected: optical & electrical. Multiple channel measurements, such as Differential TDR	Before multiple channel measurements when measuring timing differences between channels.	<b>Channel Setup</b> Calibrate Skew
External Scale	Compensates for gain or loss associated with external devices (calibrates vertical scale to external device)	Channels affected: optical & electrical. Any measurement taken through an external device (component or transducer)	Whenever using external devices (component or transducer)	<b>Channel Setup</b> External Scale



**Eye, Mask and Eyeline  
Mode Measurement  
Tutorials**

---

## Eye, Mask and Eyeline Mode Measurement Tutorials

### **What you'll find in this chapter**

This chapter consists of the following three tutorial sections:

Eye Diagram Measurements	These measurements are used to characterize the eye. They are: Extinction ratio, Eye height, Crossing %, Eye width, Jitter, Duty cycle distortion, Q-factor, Rise time, and Fall time.
Mask Measurements	The eye may be measured against a number of standard masks. One example is used in this tutorial. The eye is measured with the mask in place and then a margin measurement is made.
Eyeline Measurements	This section includes a description of the Agilent Eyeline software, and its installation and usage when used with the Agilent 83480-series digital communications analyzer.

For more information on eye or mask measurements, refer to Chapter 6 later in this manual.

---

## Making Eye Diagram Measurements

The instrument has the ability to automatically characterize an NRZ eye pattern or digital data on a digital bus. Measurements are based upon a statistical analysis of the waveform, and require a statistical database. This database is established automatically when the instrument is in color graded display mode (see the **Display** key in the menu section of this manual, for more information). Color grade mode must be activated whenever an eye measurement is made.

After completing this tutorial, you will be able to make the following eye measurements of your transmitter's data waveform.

Extinction ratio

*Agilent 83480A only or Agilent 54750A with optional 83480K upgrade.*

Eye height

Crossing percentage

Eye width

Eye jitter

Duty cycle distortion

Q-factor

*Agilent 83480A only or Agilent 54750A with optional 83480K upgrade.*

Rise time

Fall time

---

## Setting up the system

Set up the measurement system according to Figure 5-1. For this particular set of measurements, we are testing a laser source, using an Agilent 83485A plug-in module with an integrated optical to electrical converter. Measurements are also available when measuring electrical signals.

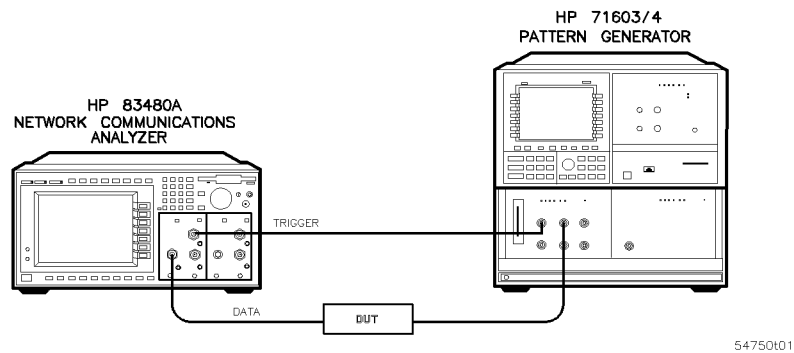

**Figure 5-1. Setting up your measurement system.**

## Positioning the waveform

To make Eye Diagram measurements, the data waveform must be properly positioned on the instrument display. The measurement algorithm needs at least two full crossing points on screen to be able to make the measurements. You should also have about four divisions of vertical scale. Refer to **\*\*\*<xref EYESCRN>: undefined\*\*\***.

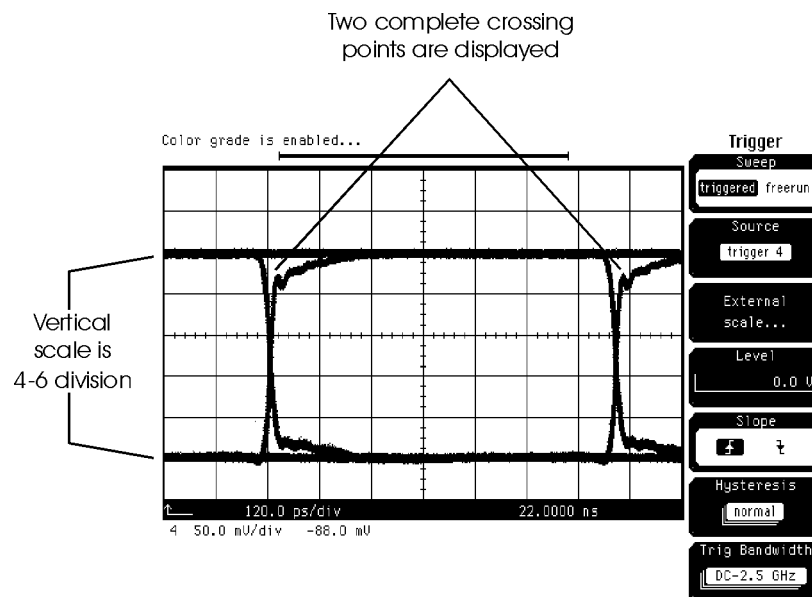

**Figure 5-2. Position of data waveform.**

To accomplish this you need to set the trigger, vertical scale, and the time base.

## Making Eye Diagram Measurements

### Setting the trigger

1. To set the trigger, press:

**Trigger**  
**Source**

Select the plug-in module where you have input the trigger signal.

2. To set the trigger level, press:

**level**

Adjust the knob so the trigger level is in the middle of its range. See the following note.

#### **NOTE**

Typically the trigger level of the instrument is set to a value midway between the high and low levels of the clock or trigger signal connected to the trigger port on the plug-in module. If the trigger signal varies between  $-1$  volts and  $0$  volts, the trigger level would be set to  $-0.5$  V. The trigger can be set to activate on either the rising or falling edge of the trigger signal.

For more information on triggering, refer to the Trigger menu section of Chapter 6 in this manual.

**Adjusting the vertical scale**

3. To adjust the vertical scale, press:  
`Channel` (on the front-panel of the plug-in module)  
`Display on`
4. To perform an optical transmitter compliance measurement, activate the filter to set the channel bandwidth by pressing:

```
Bandwidth/wavelength...  
Filter on  
Done
```

5. To adjust the vertical scale, press:

```
Scale
```

Adjust the scale for a four division data display, by using the arrow keys located next to the knob.

Selecting `Channel autoscale` will generally give you the same results.

**Selecting the time base**

6. To select the time base, press:

```
Time base  
Units bit period (Agilent 83480A only)
```

7. Select the bit rate of your transmitter. For this example, select 2.48832 GHz STM16/OC48.

```
Bit rate (Agilent 83480A only) ..... 2.48832 GHz
```

Use the arrow keys to select the desired rate.

8. Scale the waveform to show two complete crossings (refer to `***<xref EYESCRN>: undefined***`) by pressing:

```
Scale
```

Adjust the display with the arrow keys, the keypad, or the knob.

9. To center the waveform on the instrument display, press:

```
Position
```

Adjust the display with the arrow keys, the keypad, or the knob.

## Making Eye Diagram Measurements

### **NOTE**

*For Agilent 83480A only:*

The instrument has the capability to set its horizontal scale in time units, as is typical with conventional oscilloscopes, or in a scale corresponding to bit periods. By selecting bit period and entering the bit rate, the time base can then be set to show a specific number of bits. For instance, if a transmitter is operating at 2.48832 Gbit/sec, select the STM16/OC48 setting for the bit period. To display two complete eyes of the pattern, the scale is then set to two bits. If the position of the bit pattern needs to be offset by one half bit, the current position value is adjusted by one half bit. This is more intuitive than working directly in a time format.



---

## Making the measurement

Four active eye measurements may be simultaneously displayed at the bottom left side of the instrument display. Previously setup measurements remain active as new measurements are added to the bottom of the list. As these new measurements are made, the list scrolls up. If a fifth measurement is added, the first measurement is deactivated and the measurement is scrolled off the display.

To access the eye measurements described at the beginning of this section, press:

**Shift** **Meas Eye**

A column of softkeys on the right side of the instrument's screen, titled "Measure eye", is displayed.

### **NOTE**

Eye parametric measurements are made from histogram analysis of the instrument's database, rather than directly on the active channel. To make these measurements, the color grade display mode must be turned on. When selecting a measurement from the **Meas Eye** menu, the instrument will automatically turn on the color grade mode, if it is not already activated. When selecting a measurement from the choices above the numeric keypad, the user must turn on color grade *prior* to activating the measurement.

### **NOTE**

Only one channel at a time should be active to make eye measurements and other measurements on the color grade database.

---

## Measuring extinction ratio

*For Agilent 83480A only*

Extinction ratio is the ratio of the most prevalent high logic level to the most prevalent low logic level over one bit interval. As the logic low level approaches 0 volts or watts, the extinction ratio can become very high. Any residual offset signals within the instrument can become significant if their magnitude approaches the logic 0 level. A more accurate measurement of extinction ration would be:

$$\text{Extinction ratio percent} = 100 \left[ \frac{P_{base} - P_{dark}}{P_{top} - P_{dark}} \right]$$

Because of this relationship, part of the procedure for performing an extinction ratio measurement is to do a dark calibration. You are instructed to turn off the laser so that the instrument's internal offset can be measured. After the calibration is performed, data for the database will begin to acquire. Some of the data will be measured points acquired while the laser is still off, therefore, the laser should be turned on, allowed to stabilize, and then the instrument's display should be cleared to have a valid database. The extinction ratio measurement is defined using the measurement database as the mean high level over a windowed portion of the eye. This window is nominally the middle 20% of the eye.

For more information on defining your measurements, refer to the Define Measure menu in Chapter 10 of this manual.

### Marker lines

The marker lines delineate the measurement boundaries. The X markers define the measurement window. Only data taken inside this window is used to determine the measurement results. The Y markers define vertical boundaries of the measurement.

The extinction ratio measurement is made by first determining a window in the center 20% of the eye. All data points in that measurement window are used to determine the logic level 1 and 0.

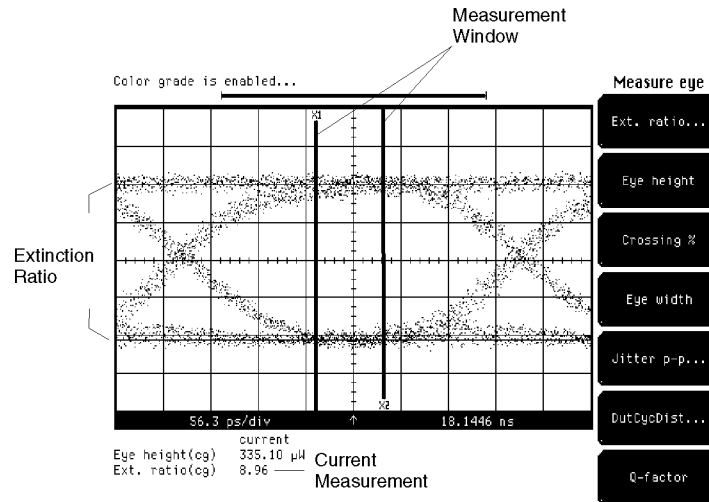

54750s10.cdr

**Figure 5.3. Extinction ratio measurement.**

1. Select **Ext. ratio...** from the softkey menus. Press **Continue** to activate the color grade database, if not currently active.
2. Select **Dark Cal** from the softkey menus, and follow the instructions displayed on the screen.
  - a. Turn off the laser, and select **Continue** from the softkey menu. This establishes a basis for the offset level of the instrument, so that a true extinction ratio measurement may be made.

**NOTE**

The dark calibration requires that the signal level, with the laser off, be on screen.

- b. Turn on the laser, let it stabilize, and select **Clear display** from the CONTROL group on the instrument's front display.

**Making Eye Diagram Measurements**

3. Select the format that you wish your measurement to be displayed by pressing the **format** softkey to cycle among **ratio**, **decibel**, and **%**.
4. Select **Enter** from the softkey menus and your measurement will be displayed on the lower left corner of the instrument display.

## Measuring eye height

Eye height is a measurement of the vertical opening of the eye. The measurement database is analyzed to determine the mean and standard deviation of the high level and low level. Eye height is defined as:

$$\text{Eye height} = (V_{top} - 3\sigma_{top}) - (V_{base} + 3\sigma_{base})$$

These measurements are made over the middle 20% of the eye by default. The measurement window can be changed by use of the **Define meas** menu.

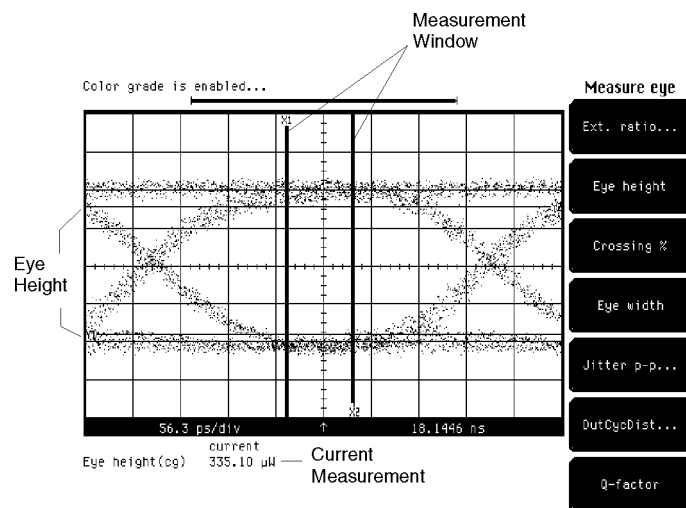

54750s07.cdr

**Figure 5-4. Eye height measurement.**

1. Select **Eye height** from the softkey menu on the instrument display, and the measurement will be displayed in the lower left corner of the instrument display.

## Measuring crossing %

Crossing percentage is a relative measurement of the amplitude of the crossing points of the eye. The mean crossing point is located first on the horizontal axis and then on the vertical axis. This is then used with the mean high and low levels as follows:

$$\text{Crossing percent} = 100 \left[ \frac{V_{cross} - V_{base}}{V_{top} - V_{base}} \right]$$

These measurements are made over the middle 20% of the eye by default. The measurement window can be changed by use of the **Define meas** menu.

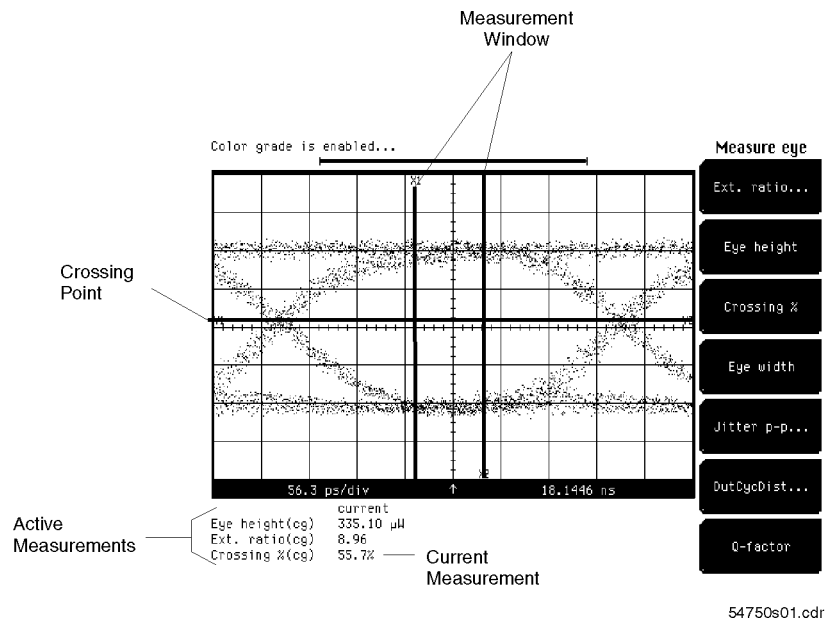

**Figure 5-5. Crossing percentage measurement.**

1. Select **Crossing %** from the softkey menu on the instrument display. The measurement will be displayed in the lower left corner of the instrument display.

## Measuring eye width

Eye width is a measurement of the horizontal opening of the eye. The mean crossing points  $T_{cross1}$ ,  $T_{cross2}$ , and horizontal standard deviation are determined. The Eye width is determined as:

$$Eye\ width = (T_{cross2} - 3\sigma_{cross}) - (T_{cross1} + 3\sigma_{cross})$$

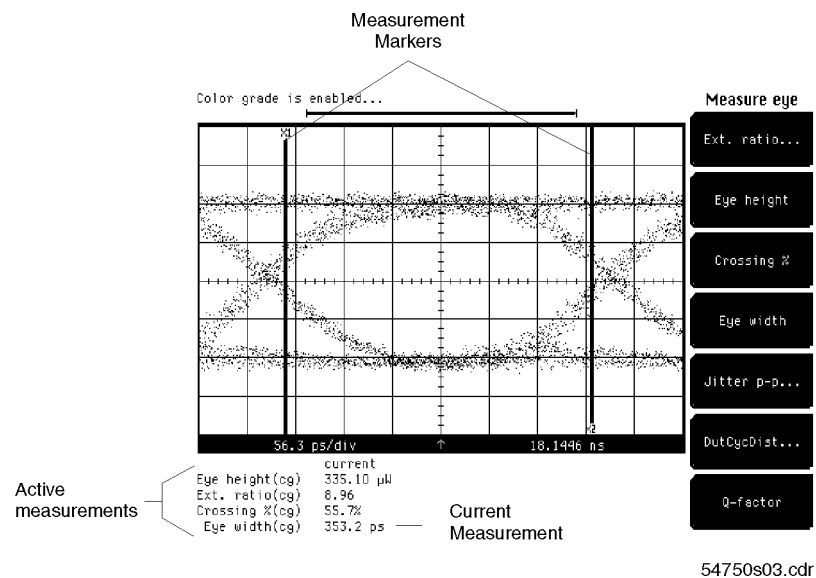

Figure 5-6. Eye width measurement.

1. Select **Eye width** from the softkey menu on the instrument display. The measurement will be displayed in the lower left corner of the instrument display.

## Measuring jitter

Jitter of the eye is determined by computing the standard deviation of the horizontal (time) histogram of the crossing point. RMS jitter is 1 standard deviation, while peak-to-peak jitter is 6 standard deviations ( $\pm 3$  standard deviations).

$$Jitter\ RMS = 1\sigma_{crossing}$$

$$Jitter\ p - p = 6\sigma_{crossing}$$

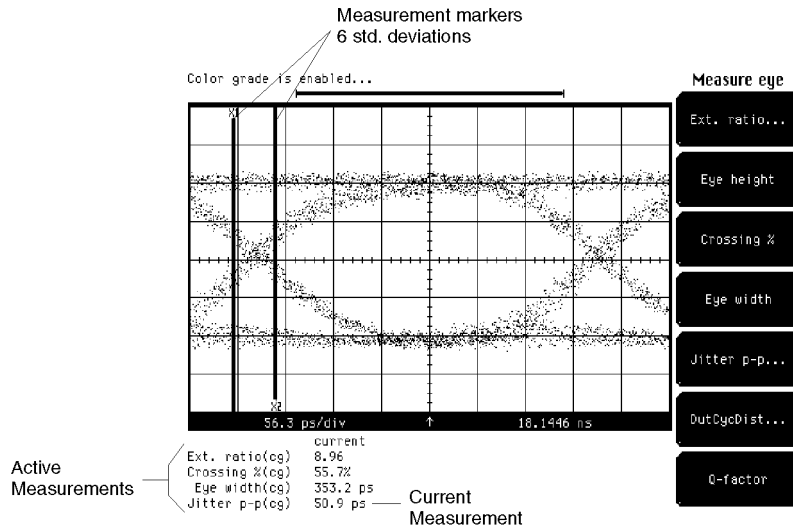

54750s05.cdr

**Figure 5-7. Jitter measurement.**

1. Select **Jitter...** from the softkey menu on the instrument display.
2. Select the format that you wish your measurement to be displayed, by selecting either **Format RMS** or and **Format p-p**.
3. Select **Enter** from the softkey menus, and your measurement will be displayed on the lower left corner of the instrument display.



## Measuring duty cycle distortion

Duty cycle distortion is a measurement of the time separation of the rising and falling edge of the eye at the center threshold level. The default center value is 50%, and can be changed in the **Define meas** menu. Narrow horizontal histograms are computed at the center threshold level to determine the mean location of the rising and falling edge at that level. The time difference between the falling and rising edge can be expressed in absolute time:

$$DCD\ time = |T_{rise\ center} - T_{fall\ center}|$$

The time difference between the falling and rising edge, expressed as a percentage of the bit period:

$$DCD\ percent = \frac{|T_{rise\ center} - T_{fall\ center}|}{bit\ period}$$

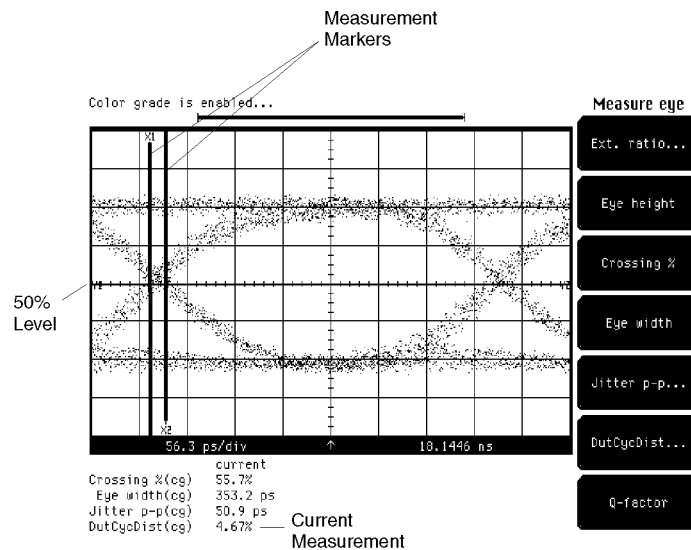

54750s09.odr

**Figure 5-8. Duty cycle distortion measurement.**

### **Making Eye Diagram Measurements**

1. Select **DutCycDist...** from the softkey menu on the instrument display.
2. Select the format that you wish your measurement to be displayed, by selecting either **Format** time or **Format** %.
3. Select **Enter** from the softkey menus. Your measurement will be displayed on the lower left corner of the instrument display.

---

## Measuring Q-factor

*For Agilent 83480A only*

Q-factor provides a figure of merit for an eye, indicating the opening of the eye relative to the noise present on the eye. The measurement data used is similar to that discussed for eye height.

$$Q - factor = (P_{top} - P_{base}) / (\sigma_{top} + \sigma_{base})$$

### **NOTE**

The measured values of  $\sigma_{top}$  and  $\sigma_{base}$  will include the Agilent 83480A channel noise. Channel noise may be larger than the signal noise, resulting in a Q-factor less than the theoretical value. For typical channel noise figures, refer to the documentation for the specific module.

Eye, Mask and Eyeline Mode Measurement Tutorials  
**Making Eye Diagram Measurements**

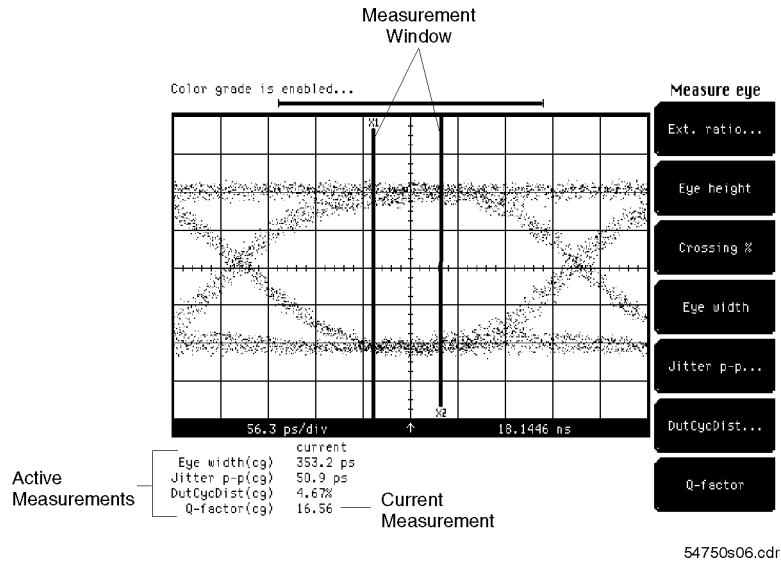

**Figure 5-9. Q-factor measurement.**

1. Select **Q-factor** from the softkey menu on the instrument display. The measurement will be displayed in the lower left corner of the instrument display.

## Measuring rise time

The rising edge of a pulse is defined as a transition that passes through the lower, middle, and upper threshold or logic levels. For an edge to be measured, it must complete the transition through all three threshold levels. Once a rising transition has been determined, the rise time may be determined by the following:

$$(\text{time at the upper threshold crossing}) - (\text{time at the lower threshold crossing}) = \text{Rise time}$$

The instrument has two standard and a user-defined threshold level for which rise time may be measured. The first is the 10% to the 90% point on the transition, and the second is the 20% to the 80% point on the transition. The 20% to 80% transition is recommended for devices with significant pulse distortion. Using the user-defined threshold levels, any point on the transition may be chosen.

The measurement threshold can be changed by use of the **Define meas** menu.

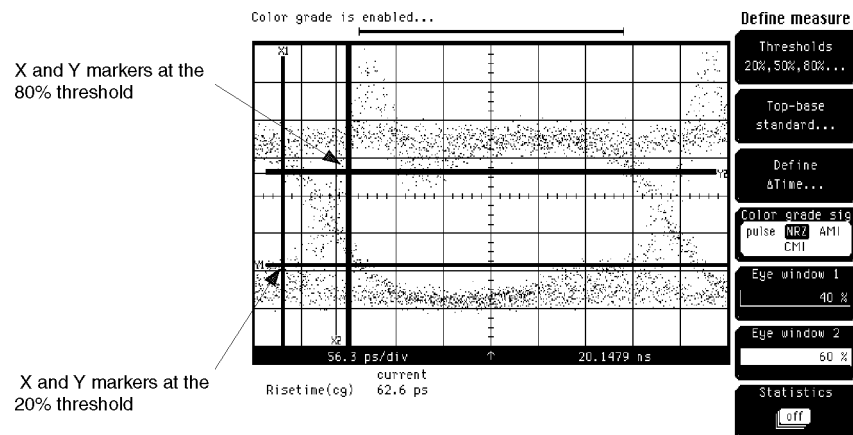

54750s02.cdr

**Figure 5-10. Rise time measurement.**

### Making Eye Diagram Measurements

1. Follow the instructions under “Positioning the waveform” earlier in this section, to position your data waveform.
2. If the optical channel filter is on, it should be turned off to remove its effect from the measurement. Select **(Channel)**, **Bandwidth/wavelength...**, **Filter** off.
3. Make sure that color grade is on. Select **(Display)**, **Color grade... on**.
4. Select the **blue** colored button from the ENTRY/MEASURE group on the instrument's front panel. This activates the **Blue Labeled** measurement functions of the instrument.
5. Select the **(Rise)** button from the ENTRY/MEASURE group on the instrument's front panel.
  - a. Select **color grade** for accurate measurements of risetime for eye waveforms.
  - b. Select **Enter**.

## Measuring fall time

The falling edge of a pulse is defined as a transition that passes through the upper, middle, and lower threshold or logic levels. For an edge to be measured, it must complete the transition through all three threshold levels. Once a falling transition has been determined, the fall time may be determined by the following:

$$(\text{time at the lower threshold crossing}) - (\text{time at the upper threshold crossing}) = \text{Fall time}$$

The instrument has two standard and a user-defined threshold level for which fall time may be measured. The first is the 10% to the 90% point on the transition, and the second is the 20% to the 80% point on the transition. The 20% to 80% transition is recommended for devices with significant pulse distortion. Using the user-defined threshold levels, any point on the transition may be chosen.

The measurement threshold can be changed by using the **Define meas** menu.

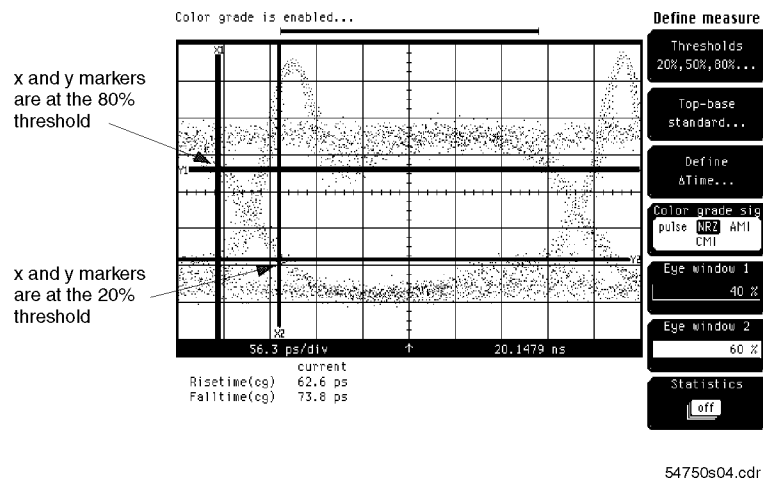

**Figure 5-11. Fall time measurement.**

### **Making Eye Diagram Measurements**

1. Follow the instructions under “Positioning the waveform”, earlier in this section, to position your data waveform.
2. If the optical channel filter is on, it should be turned off to remove its effect from the measurement.
3. Make sure that color grade is on. Select **Display**, **Color grade...** on.
4. Select the **blue** colored button from the ENTRY/MEASURE group on the instrument's front panel. This activates the **Blue Labeled** measurement functions of the instrument.
5. Select the **Fall** button from the ENTRY/MEASURE group on the instrument's front panel.
  - a. Select **color grade** for accurate measurements of falltime for eye waveforms.
  - b. Select **Enter**.



---

## Testing to a Mask

Mask testing is a test process used to verify that waveforms generated by a test device conform to a predefined standard. Typically a mask is a constellation of polygons with shapes used to define relative regions where the waveform may not exist. For NRZ digital data, mask testing is used with eye diagrams to define the required opening or center of the eye, as well as the unacceptable region above the logic 1 level and below the logic 0 level.

Both the Agilent 54750A and Agilent 83480A can test waveforms against user-defined custom masks created and stored using a built-in mask editor (refer to the Mask Menu section, located in Chapter 6). In addition, a variety of industry standard masks are integrated into the Agilent 83480A for both optical and electrical waveform test.

### Testing to a Mask

These standard masks are listed as follows.

Mask	Transmitter Bit Rate
DS1	1.54400 Mb/s
PDH	2.04800 Mb/s (fixed voltage)
DS1C	3.15200 Mb/s
DS2	6.31200 Mb/s
PDH	8.44800 Mb/s (fixed voltage)
PDH	34.3680 Mb/s (fixed voltage)
DS3	44.7360 Mb/s
STM0/OC1	51.8400 Mb/s
FDDI	125.000 Mb/s
100BASE-FX	125.000 Mb/s
FC133	132.813 Mb/s
PDH	139.000 Mb/s (fixed voltage)
DS4	139.264 Mb/s
STM1/OC3	155.520 Mb/s
FC266	265.625 Mb/s
OC9	466.560 Mb/s
FC531	531.250 Mb/s
STM4/OC12	622.080 Mb/s
OC18	933.120 Mb/s
FC1063	1.06250 Gb/s
OC24	1.24416 Gb/s
GIGABIT	1.2500 Gb/s
ETHERNET	
OC36	1.86624 Gb/s
STM16/OC48	2.48832 Gb/s
10 Gbit	9.95328 Gb/s

#### **NOTE**

The four PDH masks listed above are fixed-voltage masks. Industry standards for these masks require the signal be tested to fixed voltage limits. These masks do not scale vertically when the mask is aligned. Refer to information in "Mask Test Menu" in Chapter 6 for how to use fixed-voltage masks.

**NOTE**

The FDDI and 100BASE-FX masks are not traditional eye diagrams. They require a specific bit sequence. Refer to the appropriate standards for additional information.

---

## Setting up the system

Set up your measurement system according to the following diagram. For this particular set of measurements, we are testing a laser source using an Agilent 83485A plug-in module with an integrated optical to electrical converter.

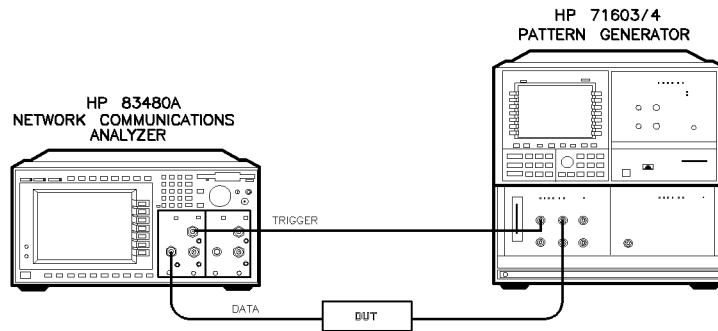

54750t01

**Figure 5-12. Setting up the measurement.**

## Testing to a Mask

---

### Positioning the waveform

*In instruments with firmware revision A.02.00 and above, two mask alignment modes are included.*

The first mode aligns the mask to the displayed waveform. This measurement algorithm needs at least one full eye on screen to perform the alignment. Refer to Figure 5-13.

The second mode optimizes the measurement by automatically adjusting the vertical and horizontal scales. The horizontal scale is set to show slightly over one bit period (as defined by the selected mask) centered on the screen, while the amplitude is set so that the eye covers approximately four vertical divisions. In this mode, it is not necessary that a full eye initially be displayed because the instrument automatically makes the appropriate adjustments.

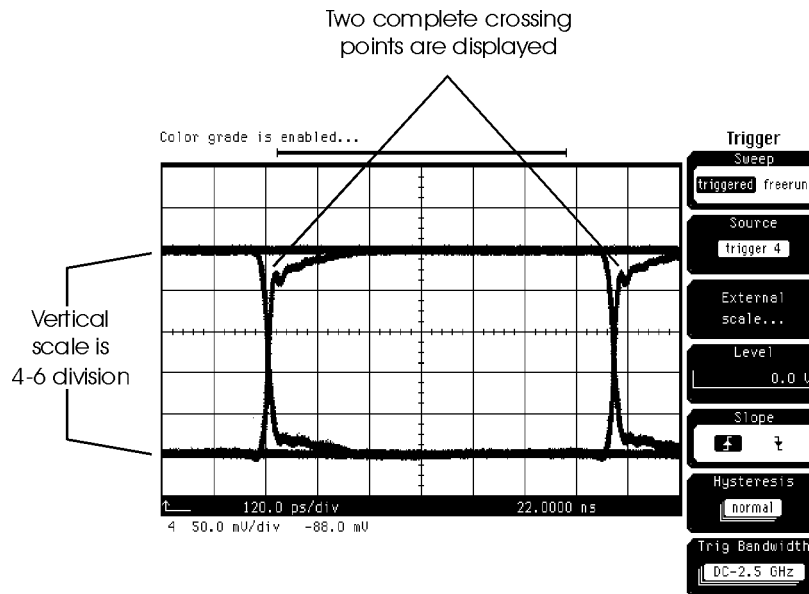

**Figure 5-13. Position of data waveform.**

To make a mask measurement you need to set the trigger, and for the mask-to-waveform mode, the vertical scale and the time base.

**Setting the trigger**

1. Select **Trigger** from the SETUP group on the front panel of the instrument.
2. Select the **Source** softkey, and then select the plug-in module where you have input your trigger signal.
3. Select the **Level** softkey and adjust the trigger level so it is in the middle of its range. See the following note.

Typically the trigger level of the instrument is set to a value that is midway between the high and low levels of the clock or trigger signal connected to the trigger port on the plug-in module. If the trigger signal varies between  $-1$  volts and  $0$  volts, the trigger level would be set to  $-0.5$  V. The trigger can be set to activate on either the rising or falling edge of the trigger signal.

For more information on triggering, see the **Trigger** menu in this manual, located in Chapter 6.

**Setting the vertical scale  
(mask-to-waveform mode only)**

1. Select **Channel** from the SETUP group on the front panel of the plug-in module, where you have input your signal.
2. Turn on the channel by selecting **Display on**. Ensure all other channels are off.
3. If an optical transmitter compliance measurement is to be performed, set the channel bandwidth by activating the filter.
4. Select **Bandwidth/wavelength...** from the softkey menus on the instrument display.
  - a. Select **Filter on**
  - b. Select **Done**.
5. Select **Scale** from the softkey menus on the instrument display.
6. Adjust the scale for a four division data display, by using the arrow keys located next to the knob. Selecting **Channel autoscale** will generally give you the same results.

## Testing to a Mask

### Setting the time base (mask-to-waveform mode only)

1. Select **Time base** from the SETUP group on the instrument's front panel.
2. Select **Units bit period**. (*Agilent 83480A only*)
3. Select the bit rate of your transmitter. For this example, select 2.48832 GHz STM16/OC48 from the **Bit rate** softkey by selecting the softkey. Scroll through the choices by using the arrow keys located next to the knob.
4. Scale your waveform to show two complete crossings (see the previous figure). Select the **Scale** softkey and adjust the display with the arrow keys, keypad, or the knob.
5. Center your waveform on the instrument display. Select the **Position** softkey and adjust the display with the arrow keys, keypad, or the knob.

#### **NOTE**

*Agilent 83480A only*

The instrument has the capability to set its horizontal scale in time units, as is typical with conventional oscilloscopes, or in a scale corresponding to bit periods. By selecting bit period and entering the bit rate, the time base can then be set to show a specific number of bits. For instance, if a transmitter is operating at 2.48832 Gbit/sec, select the STM16/OC48 setting for the bit period. To display two complete eyes of the pattern, the scale is then set to two bits. If the position of the bit pattern needs to be offset by one half bit, the current position value is simply adjusted by one half bit. This is more intuitive than working directly in a time format.

---

## Making the measurement

Mask tests are made relative to all the data that is contained in the database. Therefore, all channels, other than the one of interest, should be turned off. To access the mask tests described at the beginning of this section, use the following procedures.

1. Select the blue colored button from the ENTRY/MEASURE group on the instrument's front panel. This activates the Blue Labeled measurement functions of the instrument.
2. Select the **(Mask test)** button from the SETUP group on the instrument's front panel.

You should see a column of softkeys on the right side of the instrument's display, titled Mask test.

### **NOTE**

The database is an infinite-persistence record of all data since the last time the display was cleared. If the display is set to variable persistence, the database may contain data that is not visible on the screen. For best results, set the display to infinite persistence.

**Testing to a Mask**

---

**Standard Mask**

*Agilent 83480A only*

The following figure shows an eye diagram with the standard STM16/OC48 mask applied.

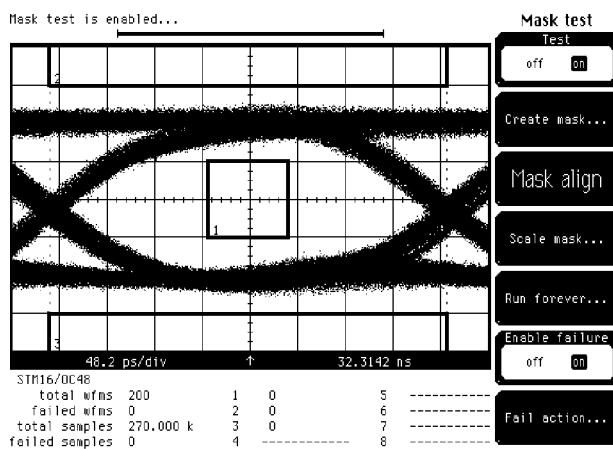

54750s11.cdr

**Figure 5-14. Eye with a mask.**



**Generating the mask**

1. Select **Mask test**.
2. Select **Create mask...** from the Mask Test softkey menu.
3. Select **Standard mask** from the Create Mask softkey menu.
  - a. Choose **Standard optical** and **Standard STM16/OC48** from the Standard softkey menu.
  - b. Press **Enter**.
4. Select **Done** on the Standard Mask menu.
5. Select **Test on** from the Mask Test softkey menu. When mask test is turned on, testing will begin. The database will be cleared and reset whenever **Clear display** is pressed, or when the horizontal or vertical scales are changed.
6. Select **Mask align** on the Mask Test softkey menu. Once the mask is aligned, it will automatically scale with the waveform as the vertical and horizontal scales and offsets are adjusted. Mask testing will be reset and begin testing after the mask has been aligned.

### Testing to a Mask

#### Verifying waveform conformance to the mask

With mask testing activated, the instrument automatically determines the waveform conformance to the mask. The following information is displayed on the bottom of the display.

STM16/OC48	This is the standard mask to which the eye is being tested.
total wfms	This is the number of waveforms taken (total samples/record length).
failed wfms	This is the number of waveforms that have violated the mask.
total samples	The number of data points compared to the mask.
failed samples	The number of data points which violate the mask.
1	This represents the number of failed samples that have violated the center (number 1) region of the mask.
2	This represents the number of failed samples that have violated the upper (number 2) region of the mask.
3	This represents the number of failed samples that have violated the lower (number 3) region of the mask.

#### Using mask margins

When a test device passes a mask test without any violations, it is often useful to determine the margin of compliance. Mask margins are used for this purpose. First a mask measurement is made, then the mask is linearly increased in size by a particular percentage. For instance, if you want to verify that the test device can comply to a standard mask with a 20% margin, the margin value is set to 20%. If a test device fails to comply to a standard mask you may set a negative margin, and determine where the device starts to fail.

#### Testing to a fixed margin

To establish a mask margin, use the following procedure:

1. Make a mask measurement as outlined in the previous procedure.
2. Select **Create mask...** on the Mask Test softkey menu.
3. Select **Mask margins on** from the Create Mask menu.
4. Set the margin percentage by selecting the **Margin %** softkey and using the knob.

You should have results similar to the following illustration. The margins will be displayed in addition to the mask. The following results will also be displayed at the bottom of the screen.

**mask margin 20%** This is the size of the margin. For this example, the margin is 20% larger than the mask.

**total hits** This is the total number of failures.

**margin hits** This is the number of failures due to the margin.

All data acquired since mask testing was enabled will be compared to the margin. Sampled points acquired before the margin was activated, that fall into the margin region, will also show up as mask hits.

**mask hits** This is the number of failures violating the mask.

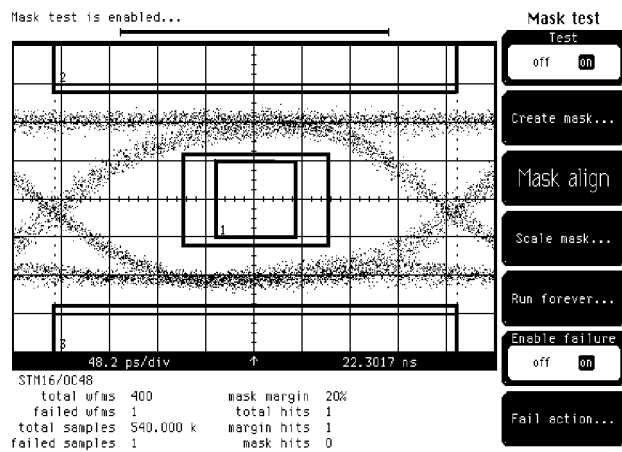

54750s12.cdr

**Figure 5-15. Mask with a 20% margin set.**

### Testing to a Mask

**Determining the margin at failure** To determine the specific margin value where a mask violation occurs:

1. With a mask selected, scaled and aligned, turn the mask test on.
2. Acquire the desired number of samples and/or waveforms that result in an accurate representation of the test device performance.
3. Stop the instrument from acquiring data. Press **(Stop/Single)**.
4. Increase the mask margin value until the monitored test data indicates mask violations.
5. The largest margin value, where no mask violations occur, yields the device margin.

---

## Making Eyeline Measurements (Agilent 83480A Option 001 only)

This section includes a description of the Agilent Eyeline software, and its installation and usage when used with the Agilent 83480-series digital communications analyzer. The benefits achieved by using Agilent Eyeline software are:

- continuous traces to show individual waveforms that make up an eye diagram, referred to as “eyeline” traces.
- noise reduction in eye diagrams through trace averaging.
- analysis of specific data patterns that lead to mask violations, referred to as “error trace capture”.

## Making Eyeline Measurements

(Agilent 83480A Option 001 only)

---

### Eyeline traces

A digital sampling oscilloscope normally displays an eye diagram as a configuration of sampled data points. While these data points accurately represent a digital data signal, there is essentially no way to view the individual waveforms or bit sequences that make up an eye pattern.

Through sequential sampling, point by point, through a repetitive data pattern, individual traces can be displayed.

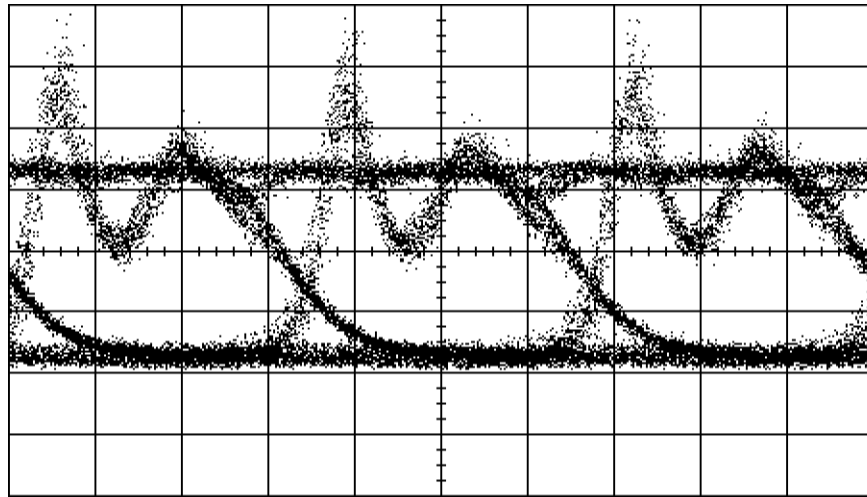
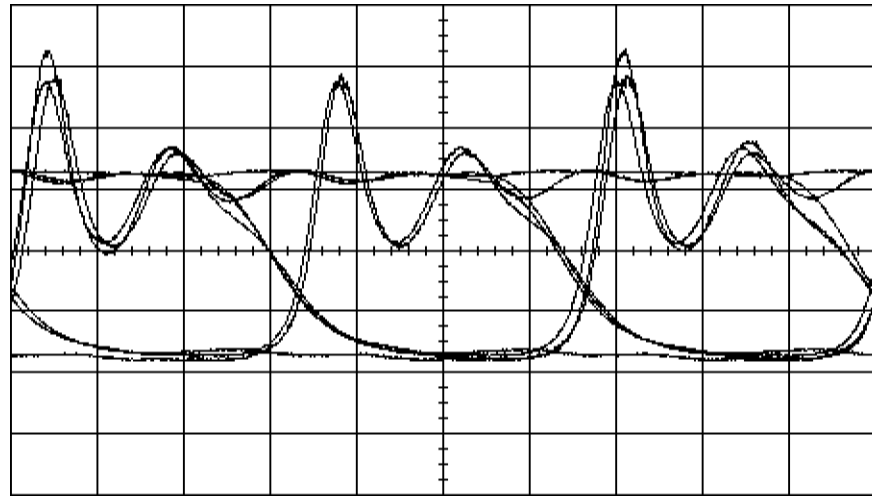

Figure 5-16. Conventional eye diagram display.



**Figure 5-17. Similar eye diagram in eyeline mode.**

When eyeline mode is active, the Agilent 83480-series digital communications analyzer controls the triggering from the pattern generator (Agilent 71603B, 71604B, 70841B, 71612A, or 70843A). One data point is taken for each valid trigger. The entire data pattern is transmitted from the pattern generator before the next trigger. Through control of the position of the trigger, relative to the data pattern, a continuous or “eyeline” trace can be produced. However, because only one data point is measured for each repetition of a data pattern, a waveform takes longer to be measured than a normal “dot” eye diagram, triggering on a true clock signal.

## Making Eycline Measurements

(Agilent 83480A Option 001 only)

---

### Noise reduction

As the power level in a signal is reduced, noise can make analysis difficult. In many measurement applications, random noise can be effectively reduced through trace averaging. Trace averaging is not a viable noise reduction technique for multi-valued waveforms, such as an eye diagram, because the result is the average between the two logic levels, which results in a collapsed eye.

Because eycline mode produces continuous traces, trace averaging can be used for noise reduction. When averaging is implemented, each eycline trace is measured  $N$  times ( $N = \#$  averages) and the average of the  $N$  traces is displayed.

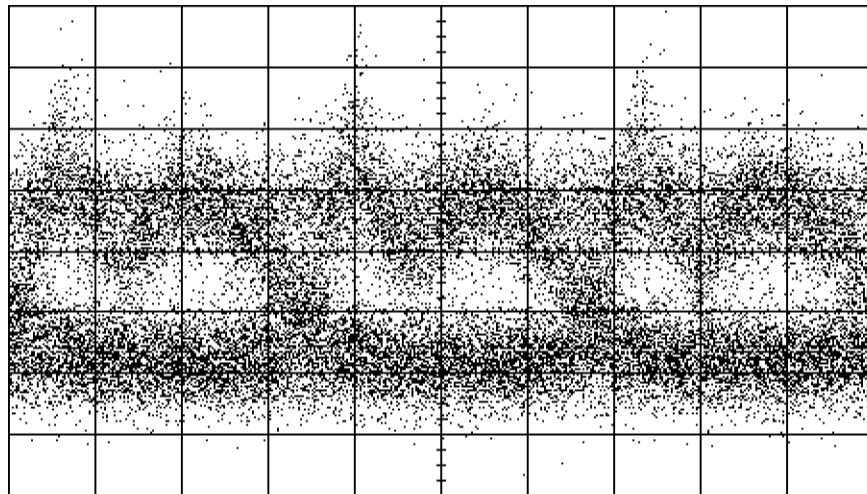

Figure 5-18. Conventional eye diagram of a low power signal.



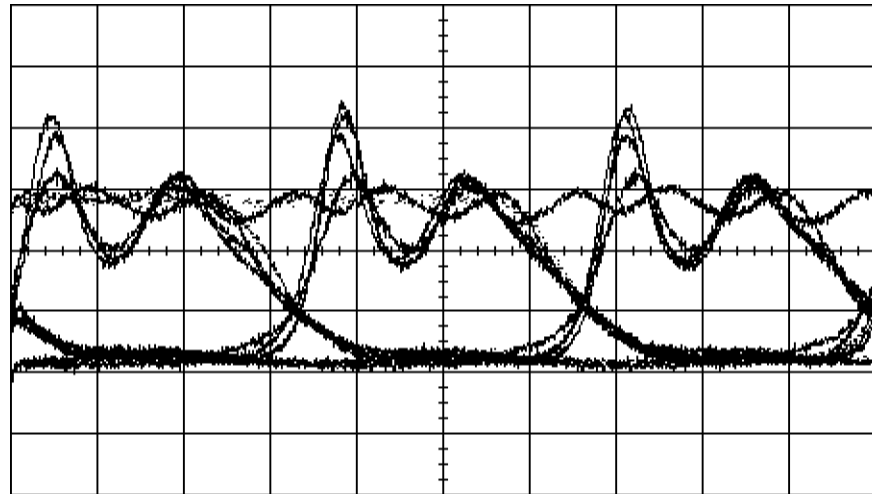

Figure 5-19. Low power signal viewed with eyeline mode using averaging.

## Making Eyeline Measurements

(Agilent 83480A Option 001 only)

---

### Error trace capture

Mask testing is a standard feature of the Agilent 83480-series digital communications analyzer. In addition to determining when mask violations occur, the eyeline application allows determination of the bit sequence that led to a mask violation.

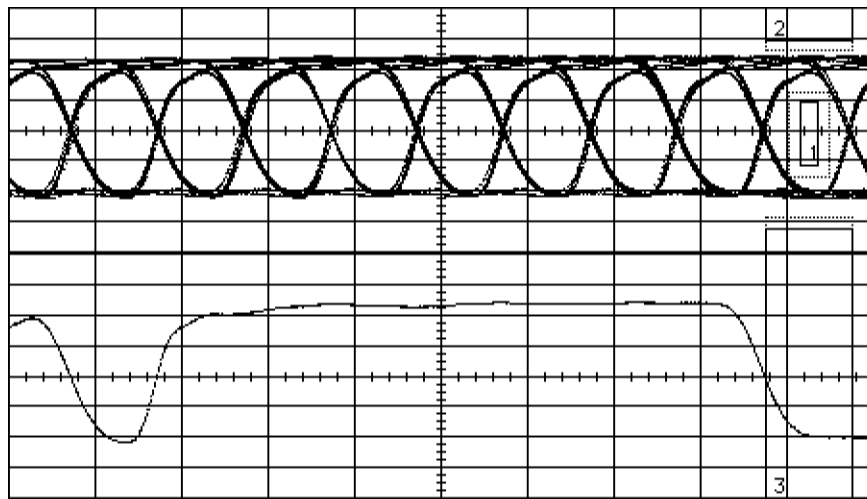

Figure 5-20. Mask violation and the sequence leading to the violation.

---

## Equipment configuration/program installation

The eyeline application will only work with the following pattern generators:

- Agilent 71603B
- Agilent 71604B
- Agilent 70841B
- Agilent 71612A
- Agilent 70843A

In the application, the trigger output (not the clock output) of the pattern generator is controlled via GPIB by the instrument. The trigger output (not the clock output) from the pattern generator must be connected to the trigger input on the instrument. Avoid excessive signal levels. On the Agilent 83480A, select **DC-2.5 GHz** triggering bandwidth when using eyeline mode. Eyeline mode is *not* compatible with **2-12 GHz** or **2-12 GHz Gate** triggering.

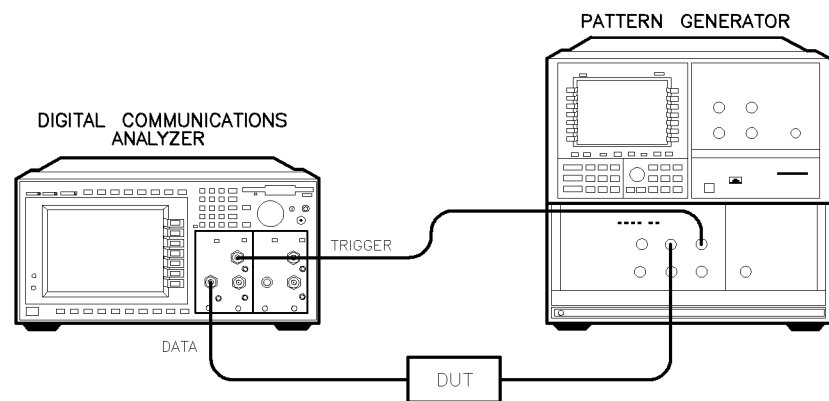

fpayem

**Figure 5-21. Front panel connection for eyeline mode.**

The GPIB cable should be connected from the analyzer to the BERT. When using the 3 Gb BERT, configured with the pattern generator as a master, the GPIB cable should be connected to the MMS mainframe containing the pattern

### Making Eycline Measurements

(Agilent 83480A Option 001 only)

generator. If the pattern generator is slaved to an error detector, the GPIB cable should be connected to the mainframe containing the error detector.

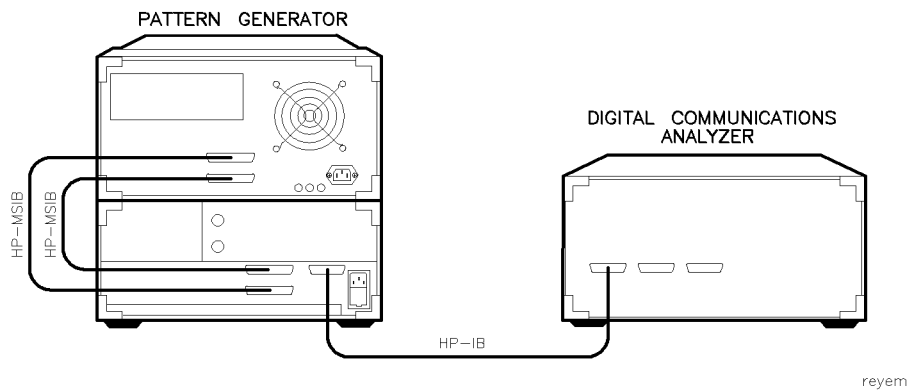

**Figure 5-22. Rear panel connection for eyeline mode.**

If the pattern generator is not set to the default GPIB address (18), go into the CONFIG menu and correct the address. The program starts when the pattern generator address is set properly.

#### **NOTE**

To display an eye diagram, increase the persistence from the minimum setting.

## Making Eyeline Measurements

(Agilent 83480A Option 001 only)

### NOTE

When the eyeline program is running, almost all front panel access is retained even though the instrument is in remote. Front-panel keystrokes are detected over GPIB and passed back to the instrument over GPIB. This slows down the front panel interface (especially the knob), so you have to be more deliberate in pressing keys to make sure a keypress is not missed. In many cases, the knob may not be useful.

### NOTE

It is usually easiest to configure the Agilent 83480-series digital communications analyzer in terms of time base, color-graded display, mask test, and so forth, *before* executing the eyeline application.

Instrument setups can be changed while eyeline is running, but observe the following:

- Ignore the message "**keypress ignored, the instrument is in remote**" that shows up when you press a key. The instrument is in remote, but it is still interpreting keystrokes. This is an instrument firmware limitation.
- When the program is running, you can halt the program by pressing:

**STOP**

The pattern generator returns to local so you can now change pattern length, bit rate, and so forth.

When you have finished making these adjustments, resume operation of the eyeline program by pressing:

**RUN**

- To exit the program completely, without unloading it from memory, press:

## Making Eycline Measurements

(Agilent 83480A Option 001 only)

**Shift** **Local**

You can now use the knob and front-panel keys at normal speed.

Note that when using **Local**, you don't actually exit the program. The program goes into an infinite loop where the only thing it does is look to see if you pressed **RESUME EYELINE**. The only way to exit the program completely is to cycle instrument power.

To return to the eyeline program from this state, press:

**Application**  
**RESUME EYELINE**

To determine if the eyeline program is loaded in memory, press:

**UTILITY**  
**SYSTEM CONFIG**

If the status menu shows **Eycline** under the application listing, the program is loaded and running in memory.

- When performing a mask alignment on an eyeline display, you must wait until enough traces have been obtained to allow accurate determination of the one level, zero level and crossing point. If you try to align the mask before sufficient data has been obtained, the mask will not align properly. In many instances, it is preferable to switch to the "eye" display mode to perform mask alignment.
- On some instrument firmware versions, if you try to activate an eye parameter measurement, such as extinction ratio, without first turning on color grading, the instrument asks if you want to turn color grading on. A menu with two keys, **CONTINUE** and **CANCEL**, is displayed. When you are running the eyeline program, these functions are not active. To get out of this state, without cycling power, press:

**Shift** **Local**  
**CONTINUE** or **CANCEL**

The program then continues normally. If you run into other situations where the program appears to stall, try this same solution.

To install the eyeline software, do the following:

1. Insert the eyeline disk into the disk drive and press:

Application

**INSTALL APPLICATION**

The software takes a couple of minutes to load.

2. Adjust the trigger, if necessary, to obtain a display on the screen.
3. To begin the program, press:

Application

#### **NOTE**

When the eyeline software first boots up, the program instructs you to adjust for a valid trigger. Once you proceed past this point in the program, you must *not* adjust the trigger level outside the valid range. If you do, the instrument will lock up. To resume operation:

- cycle power off and on, or
- readjust the trigger level to within the range established earlier

Eyeline mode is *not* compatible with **2-12 GHz** or **2-12 GHz Gate** triggering bandwidth.

The software provides two modes.

1. The eye mode displays a standard eye diagram and gives the user complete control of the pattern generator.
2. The eyeline mode puts the pattern generator in remote and executes the line mode operation.

## Making Eycline Measurements

(Agilent 83480A Option 001 only)

### NOTE

Measurement rate is strongly influenced by data pattern type and length.

Instrument throughput in eycline mode is dominated by the rate at which valid triggers are generated by the pattern generator. This is a function of the data rate, pattern length, and pattern type. The highest throughput is achieved with a zero substitution  $2^7$  or mark density  $2^7$  pattern. Longer pattern lengths are acceptable, but will reduce throughput because only one data point is measured per an entire pattern. Long PRBS patterns are not recommended because they result in the lowest throughput.

Pattern generator settings can be adjusted prior to running the eycline program or by halting remote control of the pattern generator by pressing:

**STOP**

To continue measurements, press:

**RUN**

Eycline traces are often improved through averaging. To activate averaging, press:

**Acquisition**

**Averaging on**

Whatever the number of averages is set to, this number of waveforms (complete record lengths) will be measured before a single averaged eycline trace is displayed. A tradeoff exists between throughput and noise reduction.



---

## Error trace capture

Error trace capture allows you to isolate the waveform that caused a mask violation. Before starting error trace capture, the following should be considered in setting up the measurement to ensure that the desired number of bits is displayed in the sequence leading to a mask violation.

Set the time base position to several bits, or time increment, above the lowest allowable value to ensure the full sequence is seen. For example, the minimum setting at 622 Mbit/sec is 13.7 bits. To view 10 bits, set the position to greater than 24 bits. Similarly, at 2,488 Mbit/sec, the minimum setting is 54.7 bits, so set it to >65 bits.

Set up and align the mask. You may need to wait several seconds to generate enough waveforms to create an eye diagram suitable for mask alignment. Note that the mask is aligned to the full eye closest to the left screen edge. To see the sequence leading to a mask violation, the mask must be adjusted to the right edge of the screen. This is done by simply reducing the time base position setting. Unless the mask is intentionally aligned again, it will maintain its position in time.

An appropriate formula for adjusting the mask to the right screen edge is to adjust the time base position as follows:

$$\text{new position} = \text{old position} - (\text{timebase scale in bits} - 2 \text{ bits})$$

**Making Eyeline Measurements**

(Agilent 83480A Option 001 only)

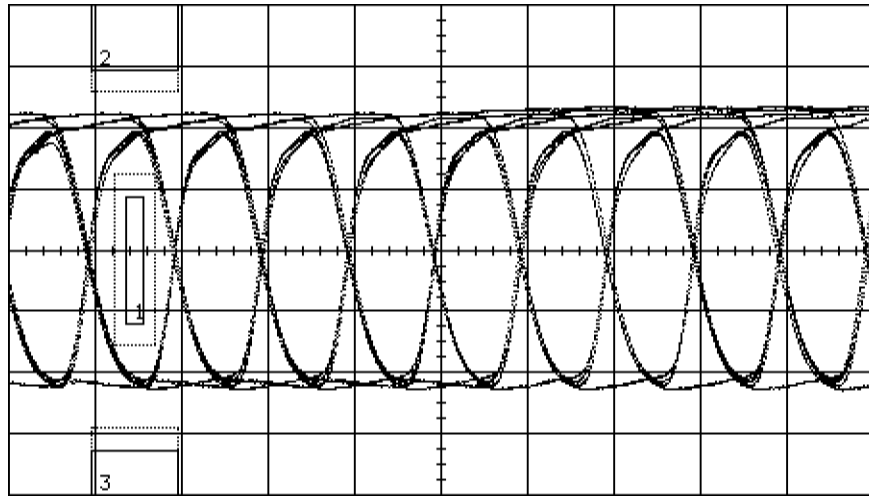

Figure 5-23. Display after initial mask alignment.

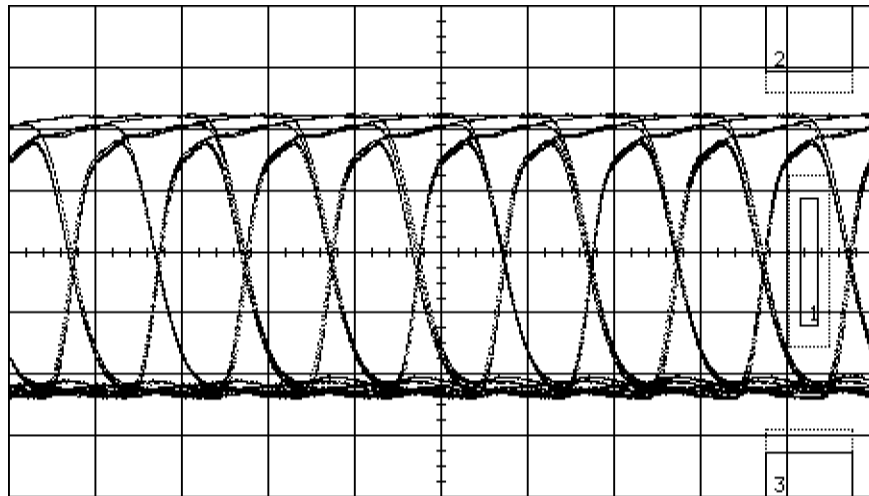

Figure 5-24. Display after time base position adjustment.

To return to the eyeline menu, press:

**Application**

Initiate error trace capture mode by pressing:

**START/CLEAR ERROR TRACE CAPTURE**

In this mode, the eye shows on the upper screen and any waveform violations show up on the bottom screen. The mask extends vertically across the entire screen, but this does not cause a problem.

The analyzer continues to measure waveforms until a mask violation occurs.

Standard masks, custom masks, or mask margins can generate violations.

When a violation occurs, the trace leading to the violation is displayed.

This trace will be updated when subsequent violations occur. To stop the measurement at this point, set the appropriate “run until” condition in the mask test menu.

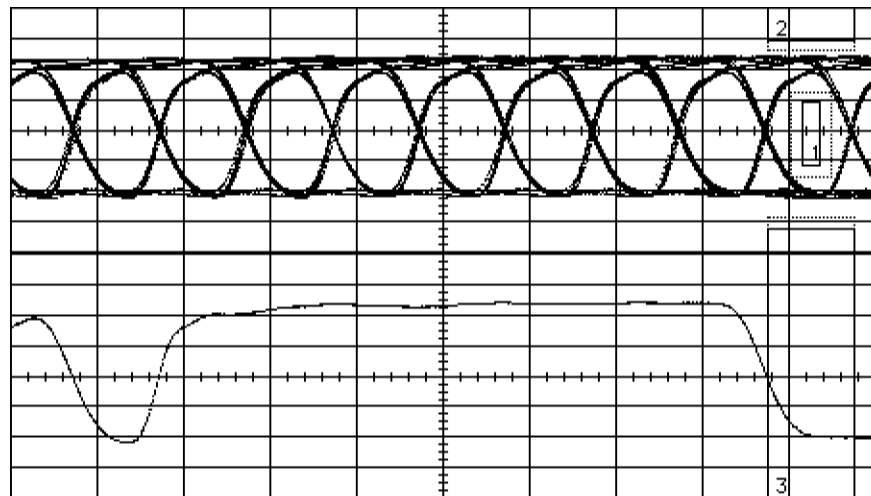

**Figure 5-25. Error trace capture example.**

The operation of error trace capture depends on the display state when you started error trace capture. If the display was set to INFINITE persistence when **START/CLEAR ERROR TRACE CAPTURE** was pressed, then the error trace display is set to infinite persistence. If it was set to VARIABLE persistence, then the display shows only the most recent error trace.

## Eye, Mask and Eyeline Mode Measurement Tutorials

To restart an Error Trace Capture display press:

**START/CLEAR ERROR TRACE CAPTURE**

Do *not* use **CLEAR DISPLAY** because it does not clear the waveform memory.

To return the instrument to a single display with no error trace displayed, press:

**CANCEL ERROR TRACE CAPTURE**

### **NOTE**

Do not change the persistence state while in Error Trace Capture mode or **CANCEL ERROR TRACE CAPTURE** may not work properly.

**The Digital  
Communications  
Analysis Menu**

---

# The Digital Communications Analysis Menus

**What you'll find in this chapter**

This chapter describes the Mask Test menu, the Measure Eye menu, the Channel Setup menu, the Time Base menu and the Trigger menu.

---

## Mask Test Menu

This instrument has been designed to perform communication industry mask tests to a variety of test standards. Mask tests may be performed by following a simple procedure. This procedure loads one of several standard mask templates, automatically aligns the mask to the present waveform, and then determines the waveform's compliance to the mask. The size of the mask, or portions of the mask, can be increased or decreased in a linear fashion to determine the waveform's margin of compliance. Both the user-defined and standard (factory-installed) masks can be stored to disk for rapid switching between instrument setups.

*In firmware revision A.02.00 and above, five mask memories are available internal to the instrument to permit custom masks to be stored without the need for a floppy drive.*

Mask testing can also activate a variety of actions upon determining a test failure. These include the storing and/or printing of:

- test results
- waveforms
- screen information

**Standard masks**

The factory-installed industry-standard masks include the following:

Optical Masks	Electrical Masks
STM0/OC1	STS1 Eye
STM1/OC3	STS1 Pulse
OC12	STS3 Eye
OC24	STS3 Pulse 0
STM16/OC48	STS3 Pulse 1
FC133	DS1
FC266	DS1C
FC531	DS2
FC1063	DS3
FDDI	PDH 2.048 Mb
100BASE-FX	PDH 8.448 Mb
GIGABIT ETHERNET	PDH 34.4 Mb
	PDH 139 Mb 0
	PDH 139 Mb 1

Any of these masks may be recalled from memory and used to test a waveform to a specific industry standard listed above.

**Fixed-voltage masks**

Industry standards for PDH data rates at 2.048 Mb/s, 8.448 Mb/s, 34.368 Mb/s, and 139.000 Mb/s require fixed-voltage masks. This means the test signal 1 and 0 voltages must fall within certain absolute limits and the mask is not permitted to scale vertically to fit the waveform.

*In firmware A.02.00 and above, the Agilent 83480A automatically performs fixed-voltage mask tests on these rates.*

There are two considerations in mask testing at these rates: the mask is specified for a 75 ohm test impedance, and the required signal swings exceed the Agilent 83480A's specified input voltage range. To convert the Agilent 83480A's input impedance to 75 ohms, use a minimum loss pad such as the Agilent 11852B. To reduce the signal level to within the input range of the Agilent 83480A, add an appropriate 50 ohm fixed attenuator between the minimum loss pad and the channel input. The Agilent 11852B has an insertion loss of 5.7 dB, and suggested additional attenuation values are listed in the table below.



**NOTE**

For proper operation, the channel external scale must be set to the total attenuation in the path. For example, when using the Agilent 11852B in conjunction with a 10 dB attenuator, set the channel external scale to 15.7 dB. To set external scale, select Channel, External Scale, and enter the appropriate attenuation value.

Data Rate	Zero Level Voltage	One Level Voltage	Recommended Pad Value <sup>1</sup>
2.048 Mb/s	0 V	2.37 V	10 dB
8.448 Mb/s	0 V	2.37 V	10 dB
34.368 Mb/s	0 V	1.00 V	6 dB
139.000 Mb/s	-0.5 V	+0.5 V	6 dB

<sup>1</sup> In addition to 5.7 dB loss due to 75-50 ohm minimum loss pad

**User-defined masks**

The Mask Test menu also contains a mask editing feature that allows you to create your own masks. These masks may be created using one of two methods: by using the Edit Mask menu to create a new or modify an existing mask, or by using the Auto Mask menu to create a mask from a waveform.

The first method involves constructing polygons, while the second method involves the use of a reference waveform.

Using the first method, polygons are created to mask off failure regions of the graticule. Up to eight polygons can be positioned in the graticule area. Each polygon can have from 3 to 512 sides. Very complex masks can be constructed by placing polygons within polygons. Similar to margin testing discussed above, this method allows testing of waveform failure rates to varying tolerances, because failures are listed individually for each polygon.

Using the reference waveform method, masks are constructed by adding a  $\Delta X$  and  $\Delta Y$  tolerance around a reference waveform. This method is simple to use, though not as flexible as the polygon method.

**NOTE**

Refer to Chapter 5 to understand the basic ideas and procedures involved in performing a mask test.

**Understanding mask testing**

Mask testing begins by defining portions of the graticule area as failure regions. If any portion of an acquired waveform enters one or more of these failure regions, the mask test considers that waveform as failing the test.

The instrument has three mask-test features:

- histograms
- mask testing
- color graded display

These features operate on a common database within the instrument's memory. This database operates independently of the waveform record for each channel. When any one of these three features are activated, the instrument begins to build the database.

The database is the size of the graticule area (256 pixels high by 451 pixels wide). Behind each pixel is a 16-bit counter. When color graded display, mask testing, or histograms are activated, a database is built by incrementing the 16-bit counters each time a pixel is hit by data from a channel or function.

The maximum count (saturation level) for each counter is 65,535. You can check to see if any of the counters are close to saturation by going to the Display menu and activating the color graded display feature. The Color Graded Display menu uses colors to represent the number of hits on various areas of the display.

The database continues to build until the instrument stops acquiring data or all three functions (color graded display, mask testing, and histograms) are deactivated. The instrument stops acquiring data when:

- the power is cycled.
- the **Stop/Single** hardkey is pressed
- the **Run until...** softkey in the Mask Limit Test or Histograms menus is set to stop acquiring data after a specified number of waveforms or samples are acquired.

Even if the display is set to show only the most recent acquisition (minimum persistence), the database keeps track of all pixel hits while the database is building.

You can clear the database by pressing:

- **Clear display**

#### **Test**

When the Test function is on, the database begins building, if color grade and histograms are not already active, and the data is compared to the current mask. When the Test function is off, the data is not compared to the mask.

#### **Key Path**

**Shift** **Mask test** **Test** on or off

#### **Create mask...**

The Create Mask function activates menus that allow the use of industry standard masks, user-defined masks, or masks defined by a reference waveform.

#### **Key Path**

**Shift** **Mask test** **Create mask...**

#### **Automask...**

The Automask function creates a mask from a reference waveform. This function is useful when you have a known good waveform. A tolerance can be defined around the waveform and other waveforms can be tested to the mask.

#### **Key Path**

**Shift** **Mask test** **Create mask** **Automask...**

### Mask Test Menu

#### Source

The Source function selects the channel, function, or memory that the mask is scaled to. For example, if  $\Delta X$  is set to 500 ns and  $\Delta Y$  is set to 100 mV, the distance between the mask limits depends on the vertical scaling of the source. If the source is set to 100 mV/div, the markers will be one division apart. If the source is set to 20 mV/div, the markers will be five divisions apart.

The source selection also defines the waveform used to create an automask.

#### Key Path

**Shift** **Mask test** Create mask... Automask... Source

#### Units

The Units function allows you to define  $\Delta X$  and  $\Delta Y$  in divisions or current source settings. Current is typically in volts and seconds or other appropriate units for the source.

#### Key Path

**Shift** **Mask test** Create mask... Automask... Units

#### $\Delta X$

The  $\Delta X$  function defines the horizontal tolerance around the edges of the reference waveform. The  $\Delta X$  value defines the tolerance around edges.

#### Key Path

**Shift** **Mask test** Create mask... Automask...  $\Delta X$

#### $\Delta Y$

The  $\Delta Y$  function defines the vertical tolerance above and below the reference waveform.

#### Key Path

**Shift** **Mask test** Create mask... Automask...  $\Delta Y$

#### Create

Creates the defined mask.

#### Key Path

**Shift** **Mask test** Create mask... Automask... Create

**Standard Mask**

The Standard Mask menu allows you to select from a variety of standard telecommunications masks. Choose **Standard** optical or electrical to access a menu of masks used for optical or electrical waveforms. Selecting the second **Standard** key accesses a list of available masks. Available masks include:

Optical Masks	Electrical Masks
STM0/OC1	STS1 Eye
STM1/OC3	STS1 Pulse
OC12	STS3 Eye
OC24	STS3 Pulse 0
STM16/OC48	STS3 Pulse 1
FC133	DS1
FC266	DS1C
FC531	DS2
FC1063	DS3
FDDI	PDH 2.048 Mb
100BASE-FX	PDH 8.448 Mb
GIGABIT ETHERNET	PDH 34.4 Mb
	PDH 139 Mb 0
	PDH 139 Mb 1

Use the RPG knob or the arrow keys to highlight the desired mask and press **Enter** to select the mask.

**Key Path**

**(Shift)** **(Mask test)** **Create mask...** **Standard mask...** **Standard** masks

The standard mask will be applied when the Done key is pressed in the Standard Mask menu.

**NOTE**

The mask will not be activated or displayed until **Mask test** **Test** on is selected.

**Edit Mask...**

The Edit Mask function gives you access to a second-level menu that allows you to construct or edit a mask using the polygon method.

**Key Path**

**Shift** **Mask test** **Create mask...** **Edit Mask...**

**NOTE**

To include mask margins with an edited mask, you must turn **Mask margins** on *before* entering the Edit Mask menu. This allows you to edit the definitions of the positive and negative 100% margin masks, as well as the standard mask definition. (The value of the margin specified in the Margin % key is unimportant because in the Edit Mask menu you are always editing the definitions of positive and negative 100% margins.)

If you do not select **Mask margins** on and create definitions for margin masks, the **Mask margins** feature will not operate correctly with the edited mask.

**Procedure to  
define a mask**

The Procedure To Define a Mask function brings up a set of brief instructions on how to construct a mask.

**Key Path**

**Shift** **Mask test** **Create mask...** **Edit Mask...**  
**Procedure to define a mask**

**polygon #**

The Polygon # function allows you to select one of the eight polygons that you want to edit or create. If the mask does not have a polygon with the selected number, you can create that polygon using the Edit Polygon menu. If a polygon is scaled off of the screen, the number of that polygon is still displayed on the screen. However, it is possible that a polygon number can obscure another polygon number. Also, if a polygon is scaled completely off the screen, that polygon is not used in the mask test.

When editing a mask with **Mask margins** set to **on**, there are three selections for each polygon: the standard mask (labeled "STD"), the 100%

negative polygon (labeled “MIN”), and the 100% positive polygon (labeled “MAX”). Each of these polygons must be edited independently to define completely both the standard and margin masks.

**NOTE**

Each point defined in the standard mask must have a corresponding point in the definition of the positive and negative margin masks, even if some of the points have identical values. This is necessary to define properly the trajectory of each point for intermediate values of mask margins.

**Key Path**

(Shift) (Mask test) Create mask... Edit Mask... polygon #

**Edit polygon...**

The Edit Polygon function gives you access to a second level menu that allows you to either edit or construct a polygon. Before entering this menu, make sure that you have the correct polygon number selected with the Polygon # softkey.

**Key Path**

(Shift) (Mask test) Create mask... Edit Mask... Edit polygon...

**Point**

The Point function selects the point on the polygon you want to edit. You can use the knob to scroll through the points on the polygon, or you can use the keypad to jump to a point on the polygon. The point selector traverses points that are previously defined.

The scope draws a dotted line from the first point to the last point. This dotted line turns to a solid line when you exit the menu. Also, you cannot cross lines as this turns one polygon into multiple polygons. For example, in Figure 6-1, A requires two polygons, while B is not a legal construction because B requires lines to cross.

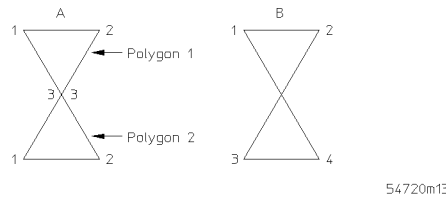

**Figure 6-1. Legal and illegal polygon construction.**

**Key Path**

**Shift** **Mask test** Create mask... Edit Mask... Edit polygon...  
**Point**

**X**

The X function moves the cursor horizontally across the display allowing you to define a point.

**Key Path**

**Shift** **Mask test** Create mask... Edit Mask... Edit polygon... **X**

**Y**

The Y function moves the cursor vertically on the display allowing you to define a point.

**Key Path**

**Shift** **Mask test** Create mask... Edit Mask... Edit polygon... **Y**



**Insert** The Insert function inserts a point at the location defined by the X and Y softkeys. The point is inserted after the point number that the Point softkey is set to, and all succeeding points are renumbered.

**Key Path** **Shift** **Mask test** Create mask... Edit Mask... Edit polygon...  
Insert

**Delete** The Delete function deletes the point selected by the Point softkey.

**Key Path** **Shift** **Mask test** Create mask... Edit Mask... Edit polygon...  
Delete

**Move** The Move function moves the selected point to the location defined by the X and Y softkeys.

**Key Path** **Shift** **Mask test** Create mask... Edit Mask... Edit polygon...  
Move

**Delete polygon** The Delete Polygon function deletes the selected polygon.

**Key Path** **Shift** **Mask test** Create mask... Edit Mask... Delete polygon

**Delete mask** The Delete Mask function deletes the selected mask.

**Key Path** **Shift** **Mask test** Create mask... Edit Mask... Delete mask

**Move polygon** The Move Polygon function moves the selected polygon by the  $\Delta X$  and  $\Delta Y$  softkeys.

**Key Path** **Shift** **Mask test** Create mask... Edit Mask... Move polygon

**To create a polygon**

1. Select the desired coordinate system from the Scale menu.
2. Select a new polygon number and then position the cursor by pressing:

```
(Shift) (Mask test)
Create mask...
Edit Mask...
polygon #
Edit polygon...
X and Y
```

3. Position the cursor at the location on the screen where you want to place the first point and then press:

```
Insert
```

The first point is displayed on the screen. The selected polygon number appears on the display next to the first point.

4. Repeat the procedure to place the second point.

The scope draws a line from the first point to the second point, and the **Point** softkey increments to the number 2.

5. Continue adding points up to a maximum of 512 points.
6. Use the **Delete** softkey to remove a point or use the **Move** softkey to change a point's location.

You may notice that after you define point number three, the scope draws a dotted line between point number one and point number three. The dotted line shows the last side of the polygon. As you add more points to the polygon, the dotted line always connects to the last point you insert. When you press the **Done** softkey to exit the Edit Mask menu, the dotted line turns into a solid line.

Moving an X or Y value off of the graticule area (value is either minimum or maximum), fixes that point to the edge of the screen. Changing the scaling will not shrink that point into the screen. For example, the top line of the polygon in Figure 6-2 looks like both points are off the screen. However, rescaling the polygon by changing the **Y2 Position** value from 1 mW to 500  $\mu$ W shrinks the polygon in Figure 6-3. You may notice that the top-left point stayed fixed to the top of the screen, while the top-right point moved into the graticule area. To keep a point fixed to a side of the graticule area, set the point's value to either minimum or maximum.

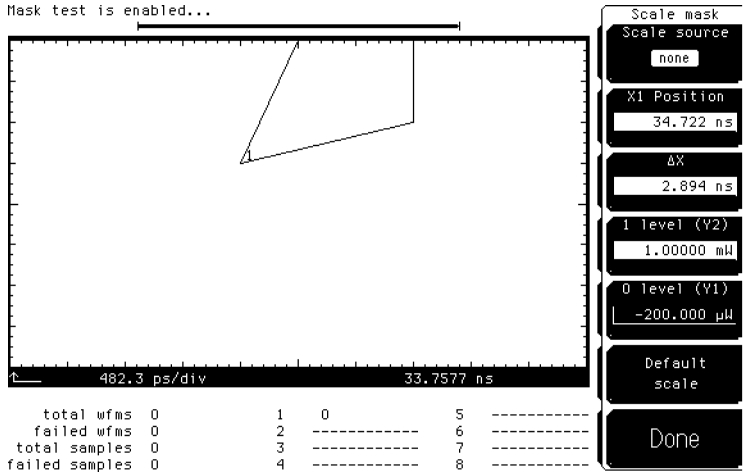
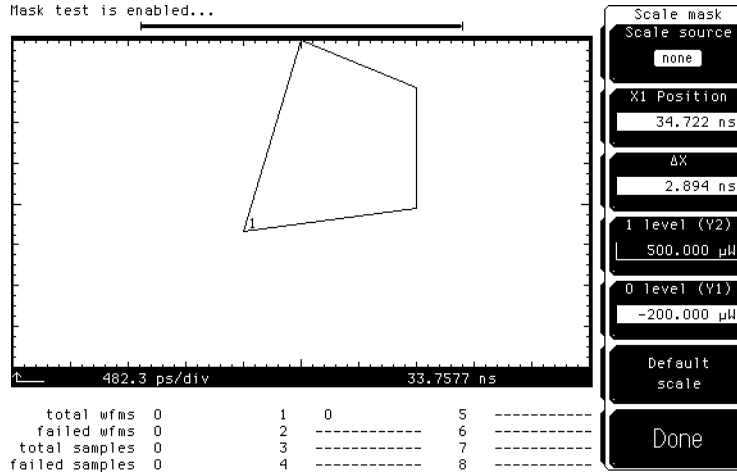

Figure 6-2. Defining a polygon.



**Figure 6-3. Rescaling a polygon.**

**To edit a polygon**

1. Select the desired coordinate system from the Scale menu.
2. Select a new polygon number and then select the point to be edited by pressing:

```

[Shift] [Mask test]
Create mask...
Edit Mask...
polygon #
Edit polygon...
Point
  
```

Use the knob or keypad to select the point on the polygon you wish to edit. The analyzer will not select an undefined point.

3. To delete the selected point, press:

```
Delete
```

- To insert a point or move a point, use the **X** and **Y** softkeys to move the cursor to the desired location and then press:

**Insert** or **Move**

**Save/recall...**

This function allows you to save or recall a previously created mask to the internal non-volatile memory of the mainframe. Up to five masks can be saved.

**Key Path**

**(Shift)** **(Mask test)** **Create mask...** **Save/recall...**

**Mask margins**

Once a mask has been selected or created, a margin can be added to the masks for tolerance testing. A mask's margin is a linear expansion of all the polygons that make up a mask in terms of the 0% margin mask and the 100% margin mask. The 100% margin mask is usually defined as a mask with a full bit width as the horizontal dimension and the full eye height as the vertical dimension. Figure 6-4 shows a mask with a 15% margin and how the 15% margin is constructed.

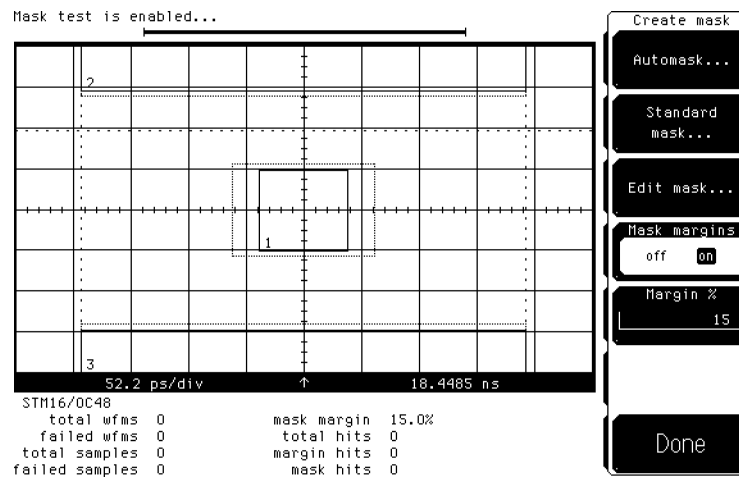

**Figure 6-4. Mask with a 15% margin.**

### Mask Test Menu

The mask margin is set by pressing **margin %** softkey and entering the desired margin as a percentage increase of the existing mask.

When **Mask test** on is selected, “hits” or violations of the margin mask, as well as the original mask, are recorded. When the mask is activated, all acquired data in the current database will be tested against the mask margin. This provides a quick and convenient method to determine waveform margin. The mask margin can be turned on with an initial value of 0. Using the RPG or arrow keys, the margin value can be increased while monitoring the margin hits. When the number of hits increases from 0 to some specific level, the margin is determined. Range is -100 to 100 percent.

#### Key Path

**Shift** **Mask test** **Create mask...** **Mask margins**

#### Margin %

The Margin % function sets the mask margin as a percentage increase of the existing mask.

#### Key Path

**Shift** **Mask test** **Create mask...** **margin %**

---

## Scale Mask

The Scale Mask function gives you access to a second level menu that allows you to set the scale of the mask when constructing custom masks. Basically, you are defining the coordinate system for the mask, where the X, Y pairs 0,0 and 1,1 are located.

**Key Path**      **Shift** **Mask test** **Scale mask**

### Scale source

The Scale Source function selects the channel, or function, that the Y1 and Y2 markers are scaled to. For example, if **Y1 Position** is set to  $-50$  mV and **Y2 Position** is set to  $+50$  mV, the distance between the markers depends on the vertical scaling of the source. If the source is set to 100 mV/div, the markers will be four divisions apart. If the source is set to 50 mV/div, the markers will be about two divisions apart.

With a channel as the source, the scaling of the X1 and  $\Delta X$  markers is set by the time/div setting in the Time Base menu. With a function or memory as the source, the scaling can be independent of the time base.

Also, the 0 level, 1 level, X1 position, and  $\Delta X$  lines show upon the display as a solid line in the Scale Mask menu, and as a dotted line in the other mask menus.

**Key Path**      **Shift** **Mask test** **Scale mask** **Scale source**

### X1 Position

The X1 Position function defines the vertical line where  $X=0$ . The X1 marker tracks the X1 Position softkey in this menu. Because the X2 marker value is assigned a delta value that is referenced to the X1 marker, you may notice that the X2 marker moves in conjunction with the X1 marker. Moving the X1 marker moves all the mask points.

**Key Path**      **Shift** **Mask test** **Scale mask** **X1 Position**

**Mask Test Menu**

**$\Delta X$**

The  $\Delta X$  function moves the X2 marker. The value is given as a delta value from the X1 marker to correspond with telecommunication applications. Moving the X2 marker moves all mask points that do not have an X value of 0. The  $\Delta X$  value usually represents a pulse width or bit period. For example, to change a mask from a 1.44-Gbit pattern to a 2.88-Gbit pattern, simply change the  $\Delta X$  value.

**Key Path**

**Shift** **Mask test** **Scale mask**  **$\Delta X$**

**1 level (Y2)**

The 1 level (Y2) function moves the Y2 marker that defines the horizontal line, or 1 level, where Y=1. Moving the Y1 marker moves all mask points that do not have a Y value of 0. The Y2 marker tracks the Y2 Position softkey.

**Key Path**

**Shift** **Mask test** **Scale mask** **1 level (Y2)**

**0 level (Y1)**

The Y1 Position function defines the horizontal line where Y=0. The Y1 marker tracks the Y1 Position softkey. This control is typically set to the value that corresponds to a logical 0.

To change between ECL to TTL when viewing the mask, simply change the 0 level and 1 level settings.

**Key Path**

**Shift** **Mask test** **Scale mask** **0 level (Y1)**

**Default scale**

When you press the **Default scale** softkey, the analyzer sets the scaling of the mask to be one division in from the edges of the graticule borders.

**Key Path**

**Shift** **Mask test** **Scale mask...** **Default scale**



---

## Mask Align

*Mask align is only enabled with Mask Test on.*

After a mask is selected, or created, it is aligned to the waveform. For example, an eye-diagram for a laser transmitter will typically require the mask to be placed in the center of the eye. In this case, the center of the eye is measured relative to the eye crossing points and the most prevalent one and zero levels.

Mask alignment is automatically performed. However, the algorithm used to determine where the mask is placed acts on all the data currently in the database. If the display is set to variable persistence, the alignment of the mask can be affected by data that is in the database, but not displayed.

### **NOTE**

To ensure *all* of the data in the database is displayed, mask testing should be performed in Infinite Persistence mode.

To ensure proper mask alignment:

- set the time base to display 2.3 bit periods
- set the vertical scaling so the complete magnitude of the waveform is displayed

Once a mask alignment is performed, the database is cleared and data acquisition begins again. Mask hits are only measured from the most recently acquired data.

### **Key Path**

**Shift** **Mask test** **Mask align**

---

## Align Mode

*In instruments with firmware revision A.02.00 and above, two mask alignment modes are available.*

The Align Mode function provides access to the Mask to Wfrm function and the Fill Display function.

### Key Path

**Shift** **Mask test** **Align mode**

### Mask to wfrm

*Available with firmware A.02.00 and higher*

The Mask to Wfrm function aligns the mask to the displayed waveform. This measurement algorithm needs at least one full eye on screen to perform the alignment.

### Key Path

**Shift** **Mask test** **Align mode** **Mask to wfrm**

### Fill Display

*Available with firmware A.02.00 and higher*

The Fill Display function optimizes the measurement by automatically adjusting the vertical and horizontal scales. The horizontal scale is set to show slightly over one bit period (as defined by the selected mask) centered on the screen, while the amplitude is set so that the eye covers approximately four vertical divisions. In this mode, it is not necessary that a full eye initially be displayed because the instrument automatically makes the appropriate adjustments.

### Key Path

**Shift** **Mask test** **Align Mode** **Fill display**

---

## Run . . .

The Run function brings up a second-level softkey menu on the display. The Run menu allows you to specify when the instrument should stop running the mask test.

**Key Path**      **Shift** **Mask test** **Run . . .**

### Mode

The Mode function allows you to configure when the mask test should stop. The five choices are run the test forever, run until a set number of failed waveforms occurs, run until a set number of failed samples occurs, run until a set number of waveforms occurs, or run until a set number of samples occurs.

**Key Path**      **Shift** **Mask test** **Run . . .**

### Forever

The Forever function runs the mask test until you turn the test off. Use the Forever mode when you want the mask test to run continually and not to stop after a fixed number of failures or acquisitions. For example, you may want the mask test to run overnight and not be limited by a number of failures or acquisitions.

**Key Path**      **Shift** **Mask test** **Run . . . forever**

### Failed wfms

The Failed Waveforms function runs the mask test until a set number of failed waveforms are acquired. When failed waveforms is selected, another softkey is displayed that allows you to set the number of failures.

**Key Path**      **Shift** **Mask test** **Run . . . failed wfms**

### Failed Samples

The Failed Samples function runs the mask test until a set number of failed samples are acquired. When failed samples is selected, another softkey is displayed that allows you to set the number of failed samples.

**Key Path**      **Shift** **Mask test** **Run . . . failed samples**

**Mask Test Menu**

**Waveforms**

The Waveforms function runs the mask test until a set number of waveforms are acquired. When waveforms is selected, another softkey is displayed that allows you to set the number of waveforms.

**Key Path**

**Shift** **Mask test** **Run . . .** **waveforms**

**Samples**

The Samples function runs the mask test until a set number of samples are acquired. When samples is selected, another softkey is displayed that allows you to set the number of samples.

**Key Path**

**Shift** **Mask test** **Run . . .** **samples**

---

## Fail action...

The Fail Action function brings up a second level softkey menu on the display. The Fail Action menu allows you to specify what the instrument does with the test data after each failure of the mask test, or after the mask test is complete.

**Key Path**      **Shift** **Mask test** **Fail action...**

**Enable Failure**      This function enables or disables all store functions for the Fail Action function. When on is selected, each store control stores the information to the selected device. When off is selected, all stores are disabled.

**Key Path**      **Shift** **Mask test** **Fail action...** **Enable failure**

**Store summary...**      The summary is a log of the mask test data from failed test results. There are two parts to the summary. The first part is a header that is a running total of the number of failures. The second part is the log of the results on each failure.

When a failure does not occur during a set of measurements, the header information is updated to show that the measurements passed, but the results are not logged to the summary file unless a failure occurred. When the screen or a waveform is logged to a disk, a line is added to the summary file that indicates the filename.

There is usually one summary file for the mask test.

The following events reset all the mask test results, which starts a new summary file.

- Changing any of the thresholds in the Define Measure menu.
- Changing one of the polygons, mask scaling, or mask source.
- Changing the trigger definition.
- Changing the filter bandwidth, if measuring filtered data.
- Changing the record length.
- Clearing the display.

**Key Path**

**Shift** **Mask test** **Fail action...** **Store summary...**

**Destination**

The Destination function brings up another menu to identify where to store the summary data.

**Key Path**

**Shift** **Mask test** **Fail action...** **Store summary...** **Destination**

The Off function deactivates printing or storing of the summary data.

The Printer function sends the summary to the destination determined by the Print selections. The destination can be one of several printers. The printer selection gives you a hardcopy of the summary information.

**NOTE**

See the Setup Print menu for a description of the selections.

The Disk function stores the summary information to a disk. The Store Summary menu allows you to specify the first four characters of the file name. The last four characters are reserved for consecutively numbering any subsequent summary files stored to the disk. If you select SUMM as the first four characters of the file name, the file name of the summary file stored to the disk is MSUM0000.SUM. The file name of the second summary file stored to the disk is MSUM0001.SUM. Each subsequent time the instrument stores a summary file to the disk, it checks which files are already on the disk, then increments the last four digits of the file name by one. If you change disks, the file number starts over again at MSUM0000.SUM.

Theoretically you can have up to 9,999 summary files. However, there are two limits that keep you from obtaining that many files. The first limit is with MS-DOS® itself. MS-DOS limits the root directory to 224 entries (an entry is either a file name or subdirectory). Because the instrument can only access files in the root directory, that limits the maximum number of files the instrument can store to a disk to 224.

The second limit is the potential size of a summary file. The size of the summary file depends on how many tests are made and the setup of the Run Until softkey.

Usually you will not have 224 summary files. However, if you are also storing screen and waveform information to the disk, there is the potential to fill up the disk. If the instrument cannot store additional files to the disk, the header portion of the summary is still updated, but additional logs are not appended to the summary file.

Messages like **Channel 1 could NOT be saved to the disk** are caused by the following conditions:

- The disk is write-protected.
- An MS-DOS disk is not in the drive.
- The disk is full.
- The maximum number of 224 files are already stored on the disk.

#### Store Screen

The Store Screen function determines what the instrument does to the data on the screen on a failure. The screen data is a pixel dump of the entire screen area. The choices are off, pixel memory, printer, disk. The screen image allows you to see what the display looked like at the time of the failure, but you cannot rescale it later like you can with waveform memories or functions. If the Help menu is displayed on the screen at the time of the failure, then the Help menu is the screen image that is stored.

#### Key Path

**Shift** **Mask test** **Fail action...** **Store screen...**

The Destination key determines where the information is stored. Choices include off, pixel memory, printer and disk.

#### Key Path

**Shift** **Mask test** **Fail action** **Store screen** **Destination**

The Off function deactivates storing, printing, or retaining of an image copy of the entire screen area.

The Pixel Memory function stores an image copy of the entire screen area to the pixel memory. (The same pixel memory that is accessed by the Waveform menu.) Additional failures are added to the composite data stored in the pixel memory. The only way to clear the pixel memory is from the Waveform menu.

**Mask Test Menu**

The value of the pixel memory selection is that you can save the waveform area from multiple failures to the pixel memory and have a composite view of the failures.

**NOTE**

See the Waveform menu for additional information on the pixel memory.

The Printer function sends the image copy of the waveform area to the destination determined by the Store Screen menu. The destination can be one of several printers. The printer selection gives you a hardcopy of what the screen looked like at the time of the failure.

The Disk function stores a image copy of the waveform area to a disk. The description for “disk” under “Store summary” in this chapter applies except that the file extension depends on the selected print format. For example, the ThinkJet selection has a .PCL extension and the TIFF selection has a .TIF extension.

**Store wforms...** The Store Wforms function sends a copy of a channel, function, or memory to the selected destination of off, memory, or disk. Waveform is not an image copy of the waveform area. A stored waveform contains the vertical and horizontal scaling factors which allows you to bring the waveform back into the instrument for measurement or rescaling.

Waveforms are stored on a source-by-source basis. For example, you can store channel 1 to a file and channel 2 to a memory.

**Key Path**

**(Shift)** **(Mask test)** **Fail action...** **Store wforms...**



**Turn Off All  
Store Wforms**

This function sets the waveform destination for all signals to off. This is a convenient way to turn off all saved waveforms if it is unknown which are being saved.

**Key Path**

**Shift Mask test Fail action... Store wforms...  
Turn off all store wforms**

**Off**

The Off function deactivates the storing, printing, or retaining of waveform data.

**Key Path**

**Shift Mask test Fail action Store wforms off**

**Memory**

The Memory function stores a copy of what the Source softkey is set to, to one of the four waveform memories; the same waveform memories that are accessed by the Waveform menu.

Because a waveform memory can contain only one waveform at a time, a waveform memory is best used when you are looking for one failure. You can send either the waveform that failed or another waveform to the waveform memory.

**Key Path**

**Shift Mask test Fail action Store wforms memory**

**Disk**

The Disk function stores a copy of the waveform to a disk. The description for “disk” under “Store summary” in this chapter applies.

**Key Path**

**Shift Mask test Fail action Store wforms disk**

---

## Measure Eye Menu

This section is intended to describe the eye measurements in detail, including the basic algorithms and measurement considerations. These measurements include:

- Extinction ratio  
*This function is only available with the Agilent 83480A, or if the Agilent 83480K option is installed in an Agilent 54750A.*
- Eye height
- Crossing percentage
- Eye width
- Jitter
- Duty cycle distortion
- Q-factor  
*This function is only available with the Agilent 83480A, or if the Agilent 83480K option is installed in an Agilent 54750A.*

### **NOTE**

If this is the first time you are using the instrument to make any or all of the eye measurements, refer to the tutorials in Chapter 5. The tutorial includes all the procedures required to perform the measurements, measurement examples, and a basic discussion on measurement results and how they are achieved.

Eye measurements are made in a fashion similar to many of the automatic measurements built into the instrument such as:

- rise and fall time
- $V_{p-p}$
- frequency

Data is acquired, histograms are built, absolute maximum and minimum voltage/power levels, as well as relative maximum (top) and minimum (base) voltage/power levels, are determined. Crossing points of the eye are located, the threshold levels are calculated, and then, depending on the specific measurement(s) activated, the requested parametric measurements are calculated (See “How to Make Waveform Measurements” in Chapter 7).

Up to four parametric measurements can be active any time a valid database exists. These measurements can include any of the eye measurements described in this section or those described in Chapter 8.

Eye measurements are performed only on a color graded database. When one of the seven measurements located in the Measure Eye menu is selected, the color graded database will be activated automatically if it has not already been enabled.

**NOTE**

The accuracy of eye measurements depends on the amount of data in the color graded database. For the first few seconds after pushing Clear Display, the amount of data may be insufficient to obtain statistically significant results, and displayed measurements may show large variability.

*In firmware revision A.02.00 and above, it is possible to set a threshold in the Define Measure menu so that measurement values are not displayed until they are stable. Refer to the description of Measure Complete in Chapter 10 for more information.*

---

## Extinction ratio...

*This function is only available with the Agilent 83480A, or if the Agilent 83480K option is installed in an Agilent 54750A.*

Extinction ratio for an eye diagram is simply the ratio of the logic “high” level ( $V_{top}$  or  $P_{top}$ ) to the logic “low” level ( $V_{base}$  or  $P_{base}$ ). A very high extinction ratio typically implies that the logic low level is very small. In the case of an optical transmitter, the logic low level would approach a condition where the laser is nearly turned off. The accuracy of the extinction ratio can be dominated by the accuracy with which the low level was measured. This in turn can be significantly affected by any noise generated by the measurement system such as O/E converter, DC offsets, or electrical offsets in the instrument electronics. Thus the extinction ratio measurement is defined as:

$$\frac{V_{top} - V_{dark}}{V_{base} - V_{dark}}$$

$V_{top}$  (or  $P_{top}$ ) and  $V_{base}$  (or  $P_{base}$ ) are determined from vertical histograms of the eye window. The eye window is the center of the eye and is defined in the Define Measure menu. The default window boundaries are 40% and 60%. Thus, the middle 20% of the eye is analyzed to determine  $V_{top}$  and  $V_{base}$ . The window can be adjusted to analyze any portion of the eye (100% window) by adjusting the window boundaries accordingly.

The vertical histogram of the eye window is used to determine the most prevalent high level and the most prevalent low value of the eye. The histogram is typically bi-modal, and  $V_{top}$  and  $V_{base}$  correspond to the means of the histogram about the most prevalent high and low values.

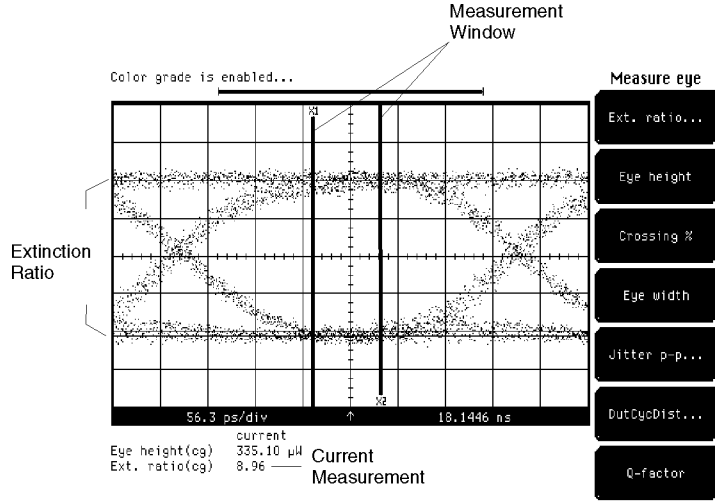

54750s10.cdr

**Figure 6-5. Extinction ratio measurement.**

**Key Path**      (Shift) (Meas\_eye) Extinction ratio...

**Dark Cal**       $V_{dark}$  is determined as part of the extinction ratio calibration routine. In this routine you are instructed to turn off the transmitter. The instrument can then characterize any internal noise signals present and remove them during the extinction ratio calculations.

**NOTE**

The dark cal routine varies slightly depending on the calibration status of the instrument. Whenever the channel offset calibration is invalid, the dark cal routine automatically invokes the offset cal routine (for optical channels only). As long as the offset cal routine remains valid, the dark cal routine performs a much faster offset correction.

**NOTE**

The dark cal routine requires that the dark signal level be on screen. If this level (for example, the signal level when a laser is turned off) is not seen on the screen, the dark cal will fail.

**Key Path**

**(Shift) (Meas eye) Extinction ratio... Dark cal**

Extinction ratio can be displayed in one of three formats:

dB  
%  
ratio

The desired format is selected in the Extinction Ratio menu.

**Key Path**

**(Shift) (Meas eye) Extinction ratio... Format ratio, decibel, or %**

The ratio format calculates extinction ratio as:

$$ratio = \frac{V_{top} - V_{dark}}{V_{base} - V_{dark}}$$

$$Extinction\ ratio\ percent = 100 \left[ \frac{V_{base} - V_{dark}}{V_{top} - V_{dark}} \right]$$

$$Extinction\ ratio\ dB = 10 \log \left[ \frac{V_{top} - V_{dark}}{V_{base} - V_{dark}} \right]$$

# Eye height

Eye height is a measurement of the vertical opening of an eye diagram. Similar to the extinction ratio measurement, a vertical histogram is calculated for data falling within the defined window (determined in the Define Measure menu).  $V_{TOP}$  and the high-levels distribution are determined. Similar patterns are determined for the low levels. The eye height is determined as:

$$Eye\ height = (V_{top} - 3\sigma_{top}) - (V_{base} + 3\sigma_{base})$$

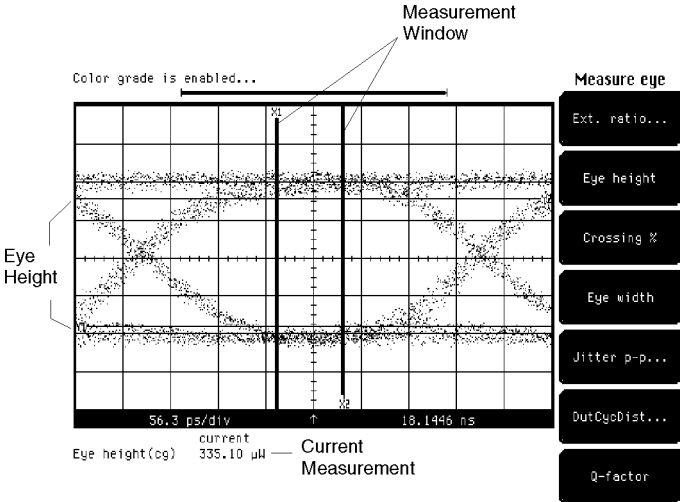

Figure 6-6. Eye height measurement.

Key Path (Shift) (Meas eye) Eye height

---

## Crossing %

Crossing percentage is a measure of the location of the eye crossing points relative to the separation between  $V_{top}$  and  $V_{base}$ . Typically, it is desirable to have the crossing points located midway between  $V_{top}$  and  $V_{base}$ . In this case the crossing percentage would be 50% according to the following formula:

$$Crossing\ percent = 100 \left[ \frac{V_{cross} - V_{base}}{V_{top} - V_{base}} \right]$$

$V_{top}$  and  $V_{base}$  are calculated from a histogram using data within the eye window as defined in the Define Measure menu.

$V_{cross}$  is the most prevalent vertical location or amplitude of the crossing points. A horizontal histogram over the entire display is used to determine the time location of the crossing points. Narrow vertical histograms are then used to determine the vertical location of  $V_{cross}$ .

### Key Path

**Shift** **Meas eye** **Crossing %**



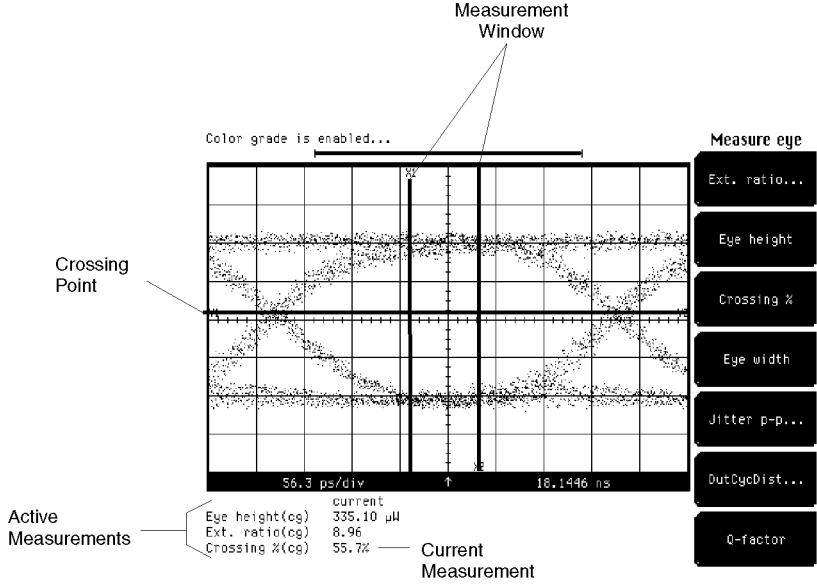

54750s01.cdr

**Figure 6-7. Crossing % measurement.**

## Eye width

Eye width is a measure of the horizontal opening of an eye diagram. A horizontal time histogram is constructed from the color grade database to determine the mean location of the crossing points, as well as the statistical distribution of the crossing points. As would be expected, noise and jitter will cause a large variance in the location of the crossing points and result in the closure of the eye.

$$Eye\ width = (T_{cross2} - 3\sigma_{cross2}) - (T_{cross1} + 3\sigma_{cross1})$$

**Key Path**

**Shift Meas eye Eye width**

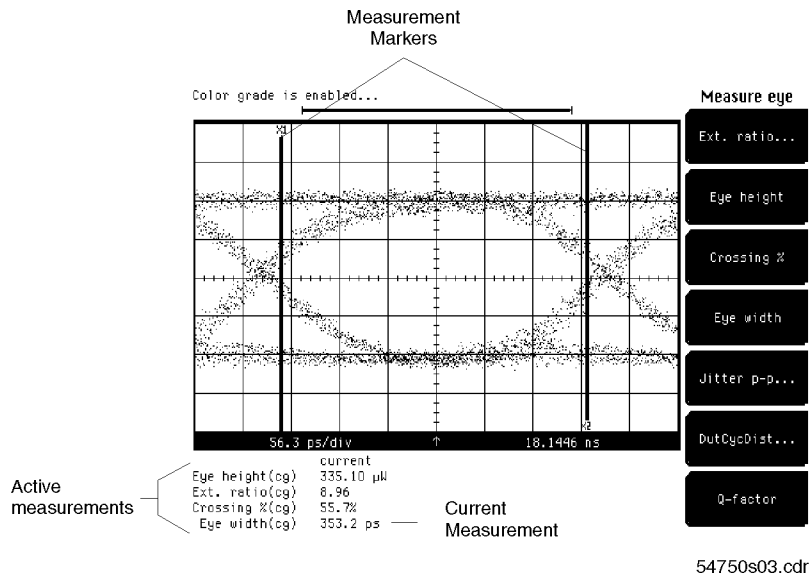

**Figure 6.8. Eye width measurement.**

# Jitter

Jitter is a measurement of the variance in time locations of the crossing points. Horizontal time histograms are constructed to determine the location of the crossing points. An iterative process is used to narrow the histogram window to precisely determine the crossing points and the variance. Jitter can be displayed in one of two formats: peak-to-peak or RMS. Both values are based on the standard deviation of the crossing point position.

*Jitter RMS = 1 σ crossing*

*Jitter p-p = 6 σ crossing*

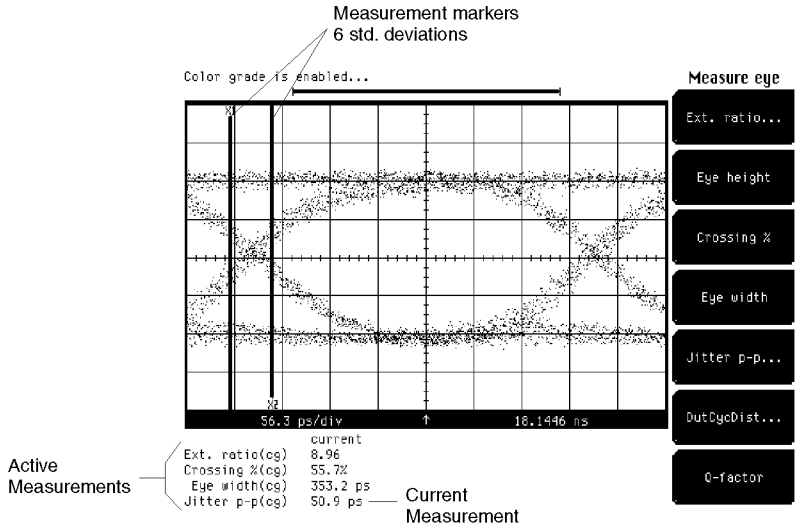

54750s05.cdr

Figure 6-9. Jitter measurement.

**Key Path**    **Shift** **Meas eye** **Jitter** **RMS** or **p-p**

## Duty cycle distortion...

Duty Cycle Distortion is a measure of the time between the falling edge and the rising edge of the eye pattern at the middle threshold. If the falling edge and the rising edge intersect precisely at the middle threshold, there is no duty cycle distortion. The middle threshold is set in the Define Measure menu. The default level is 50%. Duty cycle distortion is measured by histogram analysis at the crossing points and middle threshold.

Duty cycle distortion can be displayed in two formats: time or percent. In the time format, the actual time between the median falling edge and the median rising edge at the middle threshold is determined. In the percentage format, the time difference is determined as a percentage of the full bit width.

$$DCD\ time = |T_{rise\ 50\ percent} - T_{fall\ 50\ percent}|$$

$$DCD\ percent = \frac{|T_{rise\ 50\ percent} - T_{fall\ 50\ percent}|}{bit\ period}$$

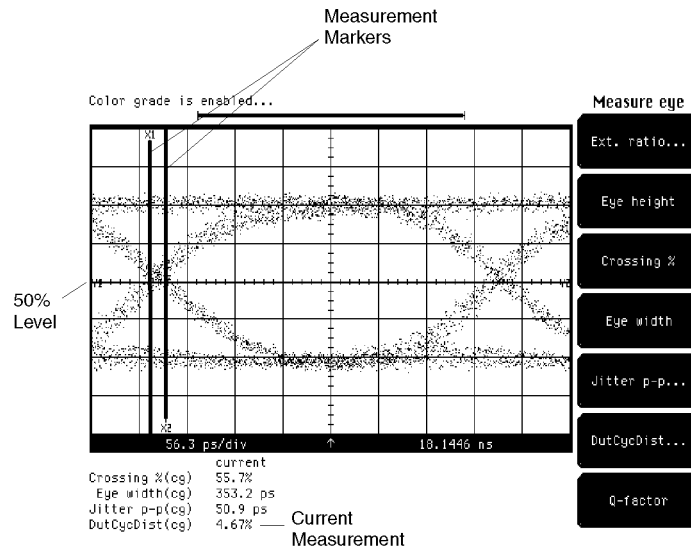

54750s09.cdr

Figure 6-10. Duty cycle distortion measurement.

**Key Path**

**Shift** **Meas eye** Duty cycle distortion... **Format** time or user|%|

---

## Q-factor

*This function is only available with the Agilent 83480A, or if the Agilent 83480K option is installed in an Agilent 54750A.*

Q-factor is a figure of merit for an eye diagram indicating the vertical eye opening relative to the noise at both the high and low logic levels. The color grade database is used to construct a vertical histogram similar to the extinction ratio and eye height measurements. The most prevalent  $P_{top}$  and  $P_{base}$ , as well as the data distribution (indicative of noise present) is calculated from the histogram. Data is collected over the eye window, defined in the Define Measure menu.

$$Q - factor = (P_{top} - P_{base}) / (\sigma_{top} + \sigma_{base})$$

### NOTE

The measured values of  $\sigma_{top}$  and  $\sigma_{base}$  will include the Agilent 83480A channel noise. Channel noise may be larger than the signal noise, resulting in a Q-factor less than the theoretical value. For typical channel noise figures, refer to the documentation for the specific module.

### Key Path

(Shift) (Meas eye) Q-factor

The Digital Communications  
 Analysis Menus  
**Measure Eye Menu**

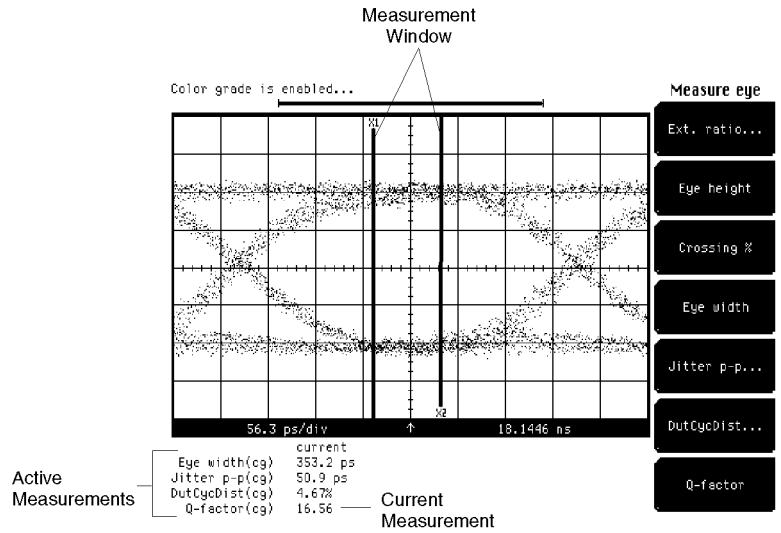

54750s06.cdr

**Figure 6-11. Measuring Q-factor.**

---

## Channel Setup Menu

This section describes the Channel Setup menu. A description of the available functions is included in the plug-in module's user's guide.

---

### **CAUTION**

The input circuits can be damaged by electrostatic discharge (ESD). Therefore, avoid applying static discharges to the front-panel input connectors. Before connecting any coaxial cable to the connectors, momentarily short the center and outer conductors of the cable together. Avoid touching the front-panel input connectors without first touching the frame of the instrument. Be sure that the instrument is properly earth-grounded to prevent buildup of static charge.

---

The Channel Setup menu is accessed from the front-panel Channel key of the appropriate plug-in module. There is a separate key for each channel. Modules with two channels have two keys, modules with one channel have one key. Most menu functions only operate on the selected channel. Some softkeys, such as Cal Status, access functions that apply to the entire module. These functions can be accessed from either Channel key.

The functions available depend on the specific plug-in module. Refer to the user's guide of the plug-in module for a complete description of the channel setup features.

The Channel Setup menu can include the following features:

- Display on/off
- Vertical scale
- Vertical offset
- Channel bandwidth
- Bessel-Thompson filter on/off
- Channel autoscale
- External attenuation factors
- Probe calibration
- Channel skew
- Module calibration status

---

## Time Base Menu

This section contains a description of the Time Base menu and how it controls the horizontal portion of the display. The topics covered are horizontal scale, position, reference, and windowing.



---

## Units

*This function is only available with the Agilent 83480A, or if the Agilent 83480K option is installed in an Agilent 54750A.*

The Units function lets you set the instrument timebase to basic time units or to bit period units. Bit period units provide an easy and intuitive way to display digital communication signals. Instead of having to compute the time interval required to display two bits or eyes, you can simply set the scale to two bits. Refer to the Scale softkey, later in this chapter.

### Key Path

**(Time Base)** **Units** time or bit period

---

## Bit Rate

*This function is only available with the Agilent 83480A, or if the Agilent 83480K option is installed in an Agilent 54750A.*

Bit rate allows the time base to be configured for a variety of standard optical and electrical telecommunications rates.

In the Bit Rate mode, the knob and arrow keys scroll between standard rates for digital communications signals. To select a non-standard rate, enter the rate from the numeric keypad. To enter values in Mb/s, enter the number followed by **(Eex)** **(6)**. To enter values in Gb/s, enter the number followed by **(Eex)** **(9)**.

### Key Path

**(Time Base)** **Bit rate**

## Scale

The Scale function changes the sweep speed from 10 ps/div to 1 s/div. If bit period has been selected for the time base units, scale is measured in bits. You can change the sweep speed with the knob, keypad, or arrow keys. The knob and arrow keys operate in two modes. One mode is a 1-2-5 step sequence, while the other mode is a fine mode that allows smaller incremental changes. The keypad allows you to enter more precise values than are possible with either the knob or arrow keys.

When the instrument is stopped, and you expand the scale, the instrument redisplay the signal at the new scale setting. This feature allows you to zoom in or to zoom out on the signal. If you watch the memory bar at the top of the display, you can see what portion of memory you are zooming on.

### Key Path

Time Base Scale

---

## Position

The Position function moves the sweep horizontally.

When the instrument is stopped, position allows you to pan across a signal. The memory bar at the top of the display indicates the portion of memory you are panning across.

The minimum position level is 22 ns, or the equivalent number of bits, depending on the bit rate selected.

### Key Path

Time Base Position

---

---

## Reference

The Reference function places the reference point to the left side or the center of the display. The Reference function defines the point at which the position is referenced. For example, if the reference is Left, then the position refers to the left of the display, whereas Center references the position to the center of the display. The reference also defines the expansion point for the time base scale control.

When Center is selected the data is acquired evenly on both sides of the reference point. The data in the waveform record is centered around the reference point, and changing the scale expands or contracts the signal about the center of the display.

When Left is selected the data is acquired starting at the Position value, and changing the scale expands or contracts the signal about the left edge of the display.

### Key Path

(Time base) Reference Center or Left

---

## Time base windowing...

The Time Base Windowing function is similar to the delayed sweep on analog oscilloscopes because it turns on an expanded time base. This expanded time base allows you to pinpoint and to horizontally expand a portion of the signal for a more detailed or high resolution analysis. It can also help you to make custom automatic measurements. Automatic measurements are made on the first occurrence of the event on the display. The windowing feature allows you to isolate individual events on the display for the automatic measurement.

**Key Path**      Time base Time base windowing... enable

**View**      View lets you select main or window.

The Main function displays the signal according to the scale and position settings, and a window marker is placed on the signal. The window marker defines the portion of the signal you plan to expand. However, the color highlight is not available when mask testing is turned on. The default color of the window marker is red, but you can change the window marker color in the Display menu.

The Window function expands and displays the portion of the signal that is outlined by the window marker. The amount of expansion depends on the window scale and window position settings.

**Key Path**      Time base Time base windowing... enable View main or window

**Time Base**      The Window Scale function controls the length of the window marker, and the maximum window scale setting is 100% of full screen. The window marker determines how much of the signal is expanded in the window mode. Increasing the window scale decreases the amount of expansion.

**Key Path**      Time base Time base windowing... enable Window scale

**Window Position**. The Window Position function moves the intensified marker horizontally across the main sweep. It allows you to pick the segment of the main sweep you wish to expand for further analysis.

**Key Path**

**Time base** Time base windowing... on **Window position**

---

## Trigger Menu

This section describes the Trigger menu, and explains how you can use its controls to trigger the instrument. The trigger circuit performs two functions. It locates the waveform of interest, and it synchronizes the instrument measurement and display to the waveform.

---

## Trigger Basics

A trigger event is defined as an edge of a selected slope (either positive or negative) that transitions through a selected voltage (trigger level).

The trigger circuit and sampler circuit operate in parallel. The sampler samples the input signal at a specific rate. The trigger circuit operates independently of the sampler circuit, and a trigger event does not have to occur at the same time as a sample point. Because the instrument knows when the trigger event happened in relation to the sampled data, the instrument knows where to place the sampled data on the display.

There are three green LEDs at the top left corner of the mainframe.

When a LED is lit, it indicates the trigger status of the instrument.

Armed	The instrument is waiting for a trigger event to occur.
Triggered	The instrument triggered on a valid trigger event.
Freerun	The instrument is automatically triggered as soon as it is armed. This is useful for seeing a waveform untriggered or for looking at a baseline.

*Agilent 83480A Option 100 only:* When in the 12 GHz mode, the triggered and freerun lights are illuminated at all times to reflect the operation of the 12 GHz trigger.

Refer to the User's Reference for the plug-in you are using for details on the trigger specifications.

---

## Sweep

The Sweep function lets you select between the Triggered and Free Run modes.

In Triggered mode, the instrument displays data only after all of the trigger conditions are met. The Triggered mode keeps the instrument from triggering and displaying data on the screen before a specific trigger event occurs. Each time the instrument triggers, it lights the Triggered LED. Then, the trigger circuit is rearmed for the next trigger event.

In Free Run mode the instrument is forced to trigger when armed, giving you glimpses of the signal, which then allows you to set up channel vertical scales to display signals.

**Key Path**      **Trigger** Sweep triggered or free run

---

## Source

The Source function displays a list of the available trigger sources. The list of available trigger sources depends on the combination of plug-ins you are using.

Changing trigger sources while the instrument is running causes newly acquired data to overwrite existing waveforms that are on the display. However, if the instrument is stopped, changing trigger sources does not change the display until the instrument starts running again.

**Key Path**      **Trigger** Source

---

## External Scale

The External Scale function can be used when the trigger signal level changes due to the use of an attenuator or a probe. The attenuator factor can be entered either as a decibel value or a ratio.

**Key Path**      **Trigger** External scale Attenunits decibel or ratio

---

## Level

*This function is not available for the 2-12 GHz bandwidth.*

Level specifies the voltage threshold that a signal must cross in order for the instrument to trigger on that signal. You can use the knob, arrow keys, or keypad to change the trigger level. You can adjust the trigger level from within any of the trigger submenus.

**Key Path**      **Trigger** Level

---

## Slope

*This function is not available for the 2-12 GHz bandwidth*

Slope specifies whether the instrument triggers on either the positive or negative edge on a signal. A positive slope is an edge that transitions through and above the trigger level. A negative slope transitions through and below the trigger level.

**Key Path**      **Trigger** Slope



---

## Hysteresis

The Hysteresis function defines the amount of hysteresis around the trigger point. Selections include normal and high sensitivity.

**Key Path**      (Trigger) Hysteresis

---

## Trig Bandwidth

The Trig Bandwidth function brings up a second-level softkey menu on the display. The Trig Bandwidth menu allows you to select the trigger mode. For more information regarding trigger bandwidth, refer to Chapter 13.

**Key Path**      (Trigger) Trig Bandwidth

**DC-2.5 GHz**      The DC-2.5 GHz function provides direct triggering on 2.5 GHz signals.

**Key Path**      (Trigger) Trig Bandwidth DC-2.5 GHz

**DC-100 MHz**      The DC-100 MHz function limits the trigger bandwidth by applying a low pass filter.

**Key Path**      (Trigger) Trig Bandwidth DC-100 MHz

**2-12 GHz**      The 2-12 GHz function allows direct triggering on 12 GHz signals. This trigger bandwidth mode can *not* be used when the Agilent 83480A is performing eyeline measurements. Use the **DC-2.5 GHz** mode instead. *This function is available on the Agilent 83480A Option 100 only.* Refer to “2-12 GHz mode (Option 100 only)” in Chapter 13 for additional information.

## The Digital Communications Analysis Menus

### Key Path

Trigger Trig Bandwidth 2-12 GHz

### 2-12 GHz Gate

The 2-12 GHz Gate function allows use of an external gating signal to extend triggering capability. This trigger bandwidth mode can *not* be used when the Agilent 83480A is performing eyeline measurements. Use the DC-2.5 GHz mode instead. *This function is available on the Agilent 83480A Option 100 only.* Refer to “2-12 GHz mode (Option 100 only)” in Chapter 13 for additional information.

### Key Path

Trigger Trig Bandwidth 2-12 GHz Gate

---

## Waveform Measurements



---

# Waveform Measurements

**What you'll find in this chapter**

This chapter describes the process the instrument uses to make general waveform measurements. It also describes the parameters that are measured and how to set up measurements for the best solution. Chapter 6 discusses how the instrument characterizes a variety of eye diagram parameters.

---

## How to Make Waveform Measurements

The waveform in Figure 7-1 shows the pulse parameters the instrument measures. Agilent Technologies has been using these IEEE parameters in its measurements for over ten years. This chapter defines these parameters and discusses how they are measured.

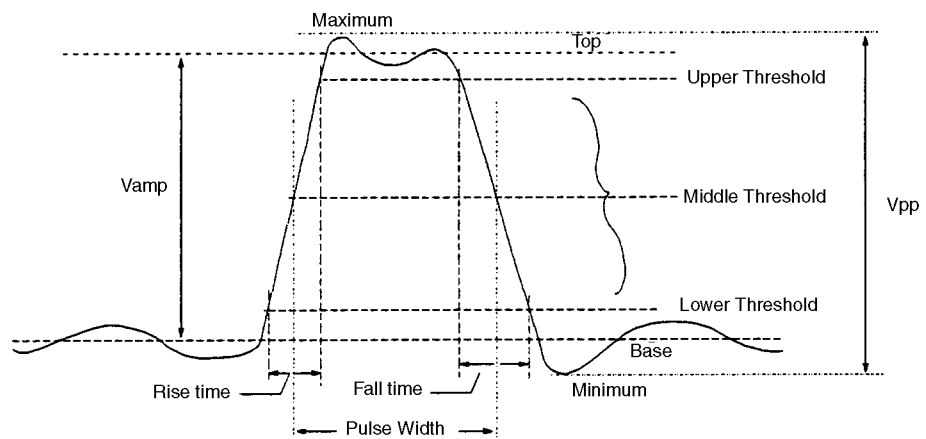

54720s12.cdr

Figure 7-1. Pulse parameters the instrument measures.

---

## The Waveform Measurement Process

Figure 7-2 shows the basic process used by the instrument when making automatic parametric measurements such as rise time,  $V_{p-p}$ , or frequency. These measurements can be made on input signals, stored waveforms, or functions.

In order to start the measurement process, the instrument captures a data record. From this data record, the instrument builds a histogram, recording how many times each  $q$  level is present in the data record. (A  $q$  level is an internal voltage representation.) From the histogram, and from the data record, the absolute maximum and minimum power or voltage levels, as well as relative maximum (top) and minimum (base) power or voltage levels, are determined. A horizontal time histogram is constructed to determine crossing points for eye diagrams. Using the top and base levels, threshold levels are calculated. The data record is again analyzed using the thresholds to determine signal edges. Finally, with all this information, the requested parametric measurements are calculated as shown in Figure 7-2.

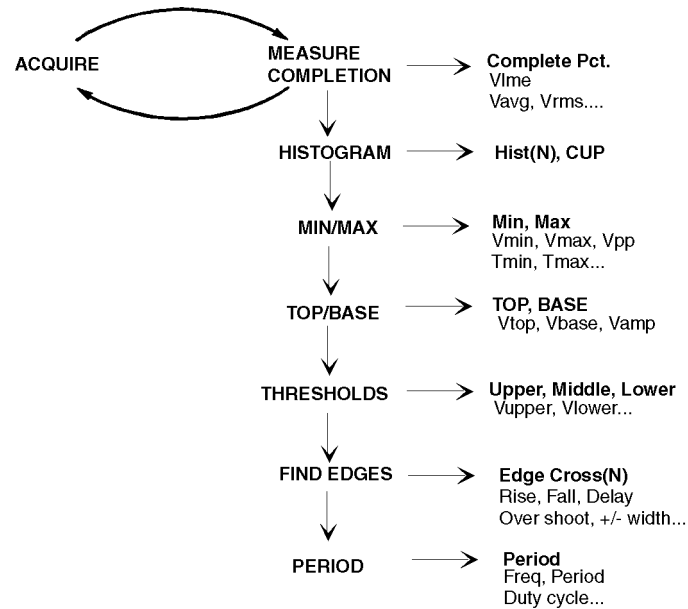
**The Waveform Measurement Process**

54720s02.cdr

Figure 7-2. The instrument uses this process for waveform measurement.

---

## Data collection

In order to make measurements on a signal, the instrument must first collect data about that signal. In the case of a live signal being measured from the front panel, the measurement process begins as soon as any data is available.

The data record used for making measurements on waveform memories is the stored data. Measurements being made on functions require that the function be calculated before the measurement process is started.

---

## Building a histogram

Once a data record is available, the measurement process builds a histogram of the distribution of the internal voltage levels as shown in Figure 7-3. The histogram does not represent the full resolution of the data, however, as this would result in a very large histogram array. The instrument uses the histogram to determine the statistical maximum (top) and minimum (base) of the data record.

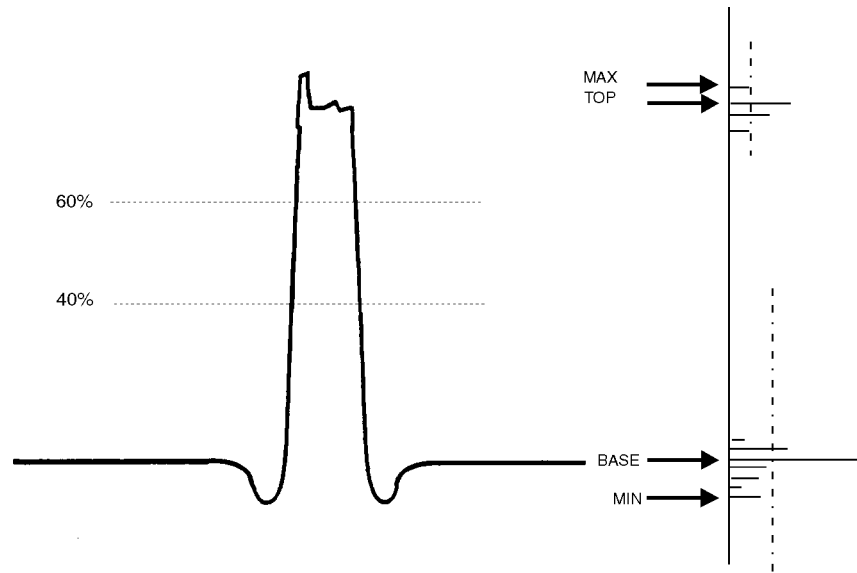

54720s04.odr

**Figure 7-3. Some measurements are made from the histogram.**



**NOTE**

When histogram or color graded database is turned on, the acquisition data is stored first in the internal database. Measurements are made on the data in the database for both histogram and color graded database.

---

## Calculating min and max from the data record

As it represents the full resolution of the signal, the absolute maximum and minimum voltage levels are determined from the data record. If the waveform is clipped, this information is also recorded. After the minimum and maximum measurements are complete, the  $V_{min}$ ,  $V_{max}$ ,  $V_{p-p}$ ,  $T_{min}$ ,  $T_{max}$ , and  $T_{volt}$  measurements can be made. The remaining primitives of the measurement process (calculate thresholds, find edge, and period) are executed only if other measurements, such as fall time, frequency, or delta time, are requested.

---

## Calculating top and base

The next measurements made are the top and base of the waveform. These measurements come directly from the histogram. The top 40 percent is scanned for the top, and the bottom 40 percent of the histogram is scanned for the base. The center portion of the histogram is not searched to prevent a baseline value from being chosen as the top or base as shown in Figure 7-4.

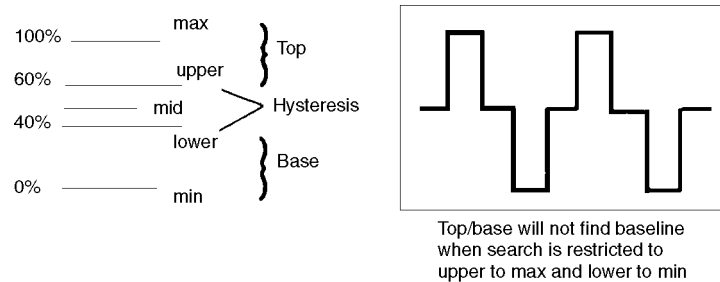

**Figure 7-4. The middle 20 percent of the waveform is ignored.**

The greatest number of data occurrences in the top half of the histogram corresponds to the top. If the occurrence count is less than a predetermined statistically significant value, the top defaults to the value of the absolute maximum. Likewise, the base represents the level with the greatest number of occurrences in the bottom portion of the histogram. If the occurrence count is less than a statistically significant value, the base defaults to the value of the absolute minimum. This may be the case for very irregular waveforms or those in which the voltage rises or falls slowly over time.

This selection technique prevents the top and base from jumping around on waves with even histogram distributions, such as triangle waves. It also allows the detection of the top and base for low duty cycle signals. The instrument also allows you to define the top and base directly in the Define Measure menu.

Measurements of eye diagrams use a color graded database. Top and base values are determined from the peak regions of the color graded database. If the measurement algorithm cannot locate these peak regions, top and base default to the absolute maximum and minimum.

Once the top and base measurements are complete,  $V_{top}$ ,  $V_{base}$ , and  $V_{amp}$  measurements can be made.

---

### Locating crossing points

When eye diagrams are measured, the crossing points are determined. Data within the top and base levels are used to construct histograms from which approximate crossing points can be determined. An iterative process is used to precisely locate the crossing point.

## Calculating thresholds

Once the top and base are defined and crossing points located (for eye diagrams), threshold levels used for timing measurements are calculated. These thresholds may be the IEEE values of 10, 50, and 90 percent, 20, 50 and 80 percent, or values in percentages or watts or volts that you set. These thresholds are called upper, middle, and lower thresholds in the Measurement menu.

These thresholds are used by all timing measurements as they are needed to determine the presence of a rising or falling edge. In addition, the thresholds are used by various measurements. For example, rise time is measured from the lower threshold to the upper threshold of a rising edge. Period and frequency measurements use the middle threshold as shown in Figure 7-5. Refer to Chapter 10 for information on manually setting the thresholds.

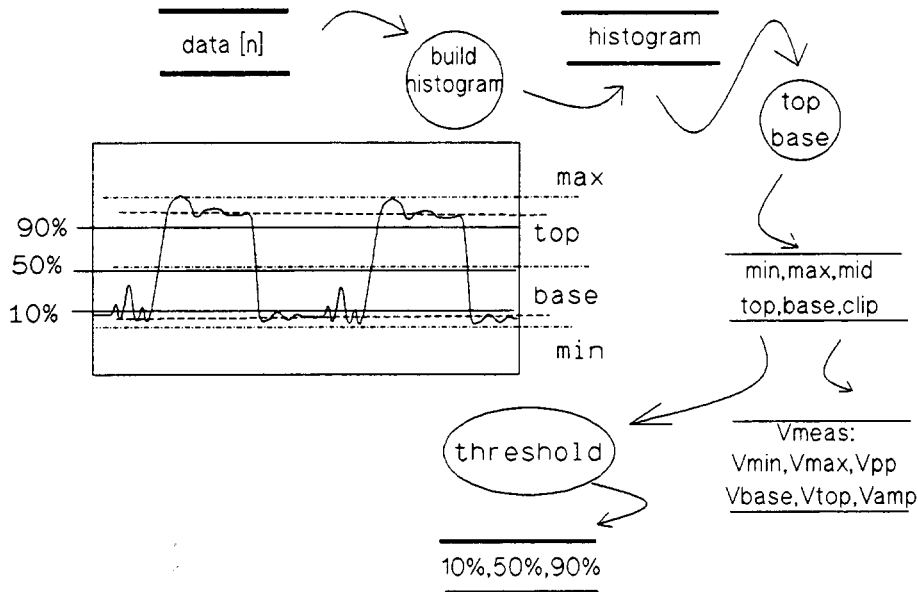

54720s06

Figure 7-5. Calculating the 10, 50, and 90 percent thresholds.

## Determining rising and falling edges

The final analysis needed to make timing measurements is to define the transition points of the waveform through the threshold levels and to define the rising and falling edges. A rising edge is defined as a transition that passes through the lower, middle, and upper threshold levels. A falling edge is defined as a transition that passes through the upper, middle, and lower threshold levels. For an edge to be present and defined, it must complete the transition through all three threshold levels.

Once the transition points and edges are identified, the instrument next calculates timing measurements (rise time, fall time, and frequency). Finally, it calculates voltage measurements that need timing information ( $V_{rms}$  cycle and  $V_{avg}$  cycle) as shown in Figure 7-6.

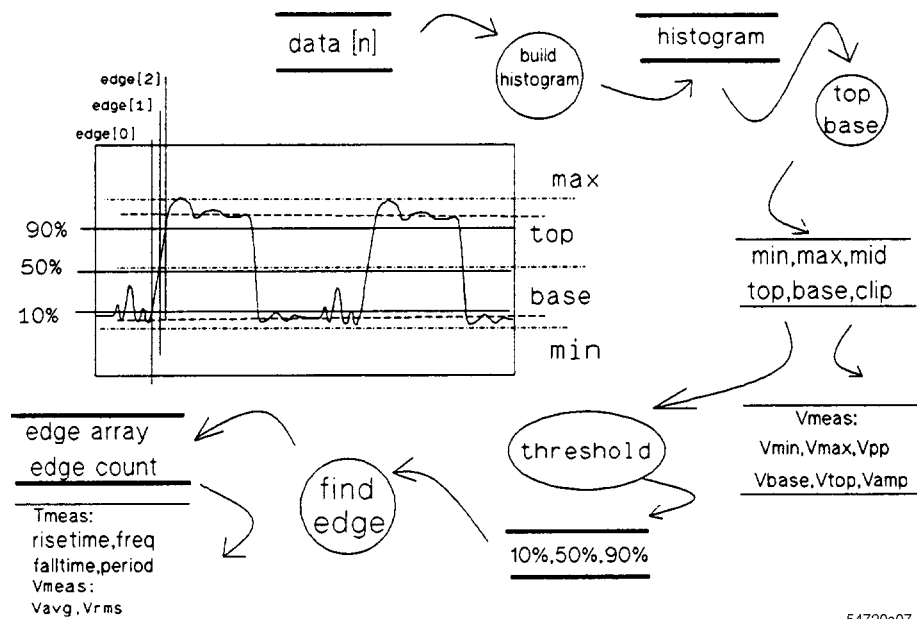

54720s07

Figure 7-6. Thresholds are used to determine edges.

**The Waveform Measurement Process**

If there are not enough points on an edge, the measurement is either not made or is flagged as questionable.

The instrument scans the waveform data and records the transitions through the three thresholds. If a waveform data point does not exactly correspond to the threshold level value, the system interpolates between the two points about the threshold. Then the location of the transition point is recorded in an edge array. The system ignores incomplete transitions and glitches as shown in Figure 7-7.

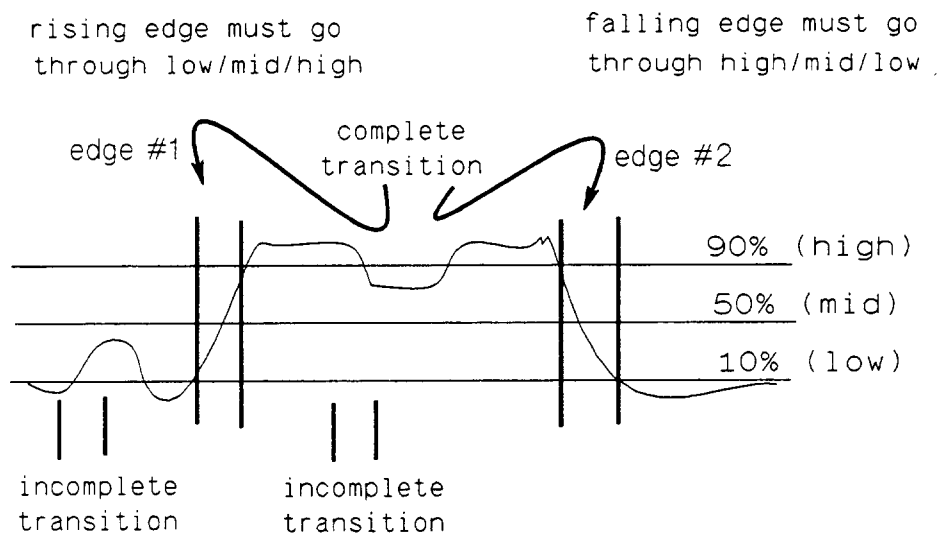

54720s08

**Figure 7-7. The system ignores incomplete transitions when defining edges.**

The instrument defines the points on a rising edge as the last point before crossing the lower threshold to the first point crossing the upper threshold. The points on a falling edge include the last point before crossing the upper threshold to the first point crossing the lower threshold. This will measure the fastest rise and fall times.

As shown in Figure 7-8, it is clear that measuring the rise time from the first point crossing the lower threshold to the last point through the upper threshold gives a different answer than the shaded line that uses the edge definition given in the previous paragraph.

The points in a period are defined to be the midpoint between the first point before crossing the middle threshold to the last point after crossing the middle threshold.

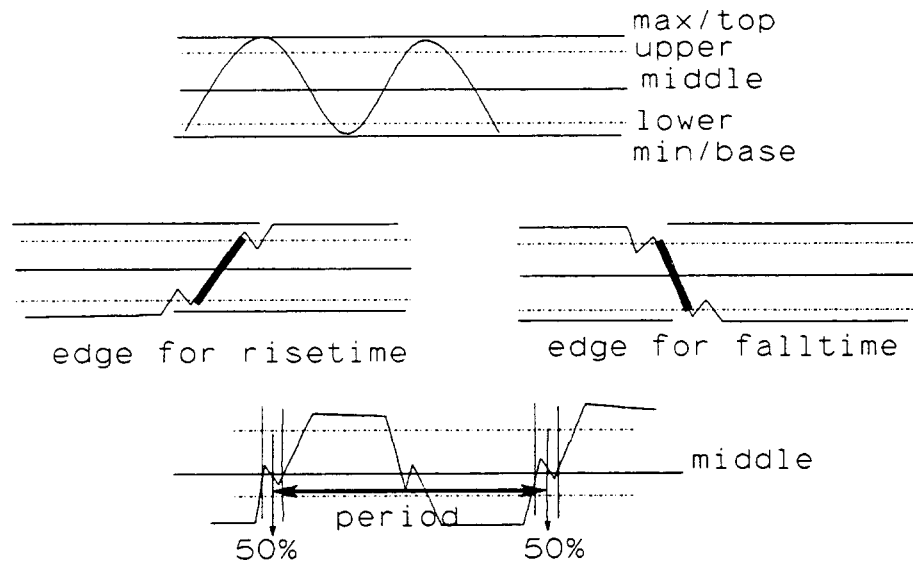

54720s09

**Figure 7-8. Waveform period is measured at the middle threshold.**

---

## Standard Waveform Definitions

The following definitions of voltage and timing measurements will help you understand just what each measurement consists of. This information might be important in helping you interpret measurement results.

---

### Voltage and power measurements

Once the top and base calculations are completed, most of the voltage or optical power measurements can be made.

<b>Vmin</b>	<i>Vmin = voltage or power of the absolute minimum level</i>
<b>Vmax</b>	<i>Vmax = voltage or power of the absolute maximum level</i>
<b>Vp-p</b>	<i>Vp-p = Vmax - Vmin or Pmax - Pmin</i>
<b>Vbase</b>	<i>Vbase = voltage or power of the statistical minimum level</i>
<b>Vtop</b>	<i>Vtop = voltage or power of the statistical maximum level</i>



**Vamp**

$$V_{amp} = V_{top} - V_{base} \text{ or } P_{top} - P_{base}$$

The base value may be equal to the min value and the top value may be equal to the max value for many waveforms, such as triangle waveforms. Figure 7-9 shows where these waveform definitions occur.

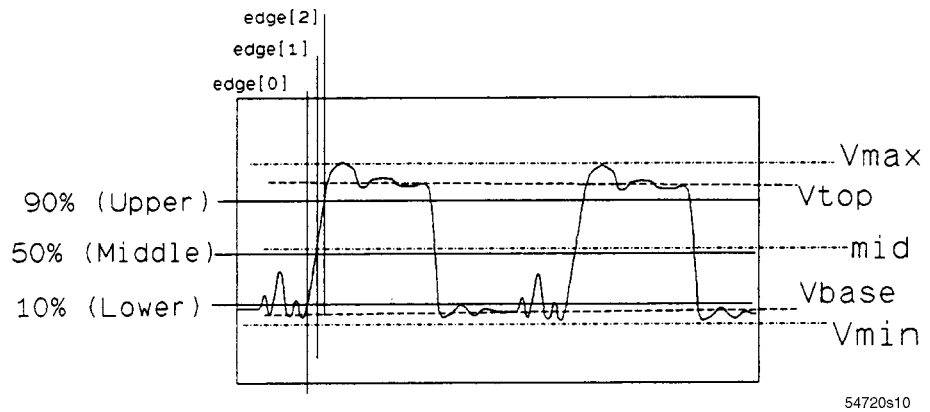

**Figure 7-9. Waveform definitions used to make voltage measurements.**

Several of the voltage measurements require threshold and edge information before they can be made.

**Vavg cycle**

*Vavg cycle = average voltage of the first cycle of the signal*

**Vavg**

*Vavg = average voltage of all data on the display*

**dc Vrms**

$$dc V_{rms} = \sqrt{\frac{v^2(t)}{n}}$$

**ac Vrms**

$$ac V_{rms} = \sqrt{(v(t) - V_{avg})(v(td) - V_{avg})/n}$$

**Standard Waveform Definitions**

**Overshoot**

Overshoot is a distortion which follows a major transition.

If first edge is rising,

$$\text{overshoot} = \text{local max} - \text{top}$$

Else,

$$\text{overshoot} = \text{base} - \text{local min}$$

**Preshoot**

Preshoot is a distortion which precedes a major transition.

If first edge is falling,

$$\text{preshoot} = \text{base} - \text{local min}$$

Else,

$$\text{preshoot} = \text{local max} - \text{top}$$

The instrument computes a local minimum and maximum when computing preshoot and overshoot. The local minimum or maximum occurs before the first transition in the case of preshoot or in the first 50 percent of the time defined along the threshold in the case of overshoot. This makes windowing less critical for these measurements.

**NOTE**

Preshoot, dc Vrms, and ac Vrms measurements are not available for a color graded histogram display.

---

## Timing definitions

Once the edges and transition points have been defined, timing measurements are made. Timing measurements are made on the first rising or falling edge on the display.

**Rise time**      *Rise time = time at the upper threshold – time at the lower threshold on the first rising edge*

**Fall time**      *Fall time = time at the lower threshold – time at the upper threshold on the first falling edge*

**Period**      If the first edge is rising,  
*period = mid-threshold crossing of second rising edge – mid-threshold crossing of first rising edge*

Else,

*period = mid-threshold crossing of second falling edge – mid-threshold crossing of first falling edge*

For an eye measurement period,

*period = time of second eye crossing – time of first eye crossing*

**Frequency**      *Frequency = 1/period*

**Standard Waveform Definitions**

**+Width**

If first edge is rising

*+Width = mid-threshold crossing of first falling edge – mid-threshold crossing of first rising edge*

Else,

*+Width = mid-threshold crossing of second falling edge – mid-threshold crossing of first rising edge*

**–Width**

If first edge is rising,

*–Width = mid-threshold crossing of second rising edge – mid-threshold crossing of first falling edge*

Else,

*–Width = mid-threshold crossing of first rising edge – mid-threshold crossing of first falling edge*

**Duty cycle**

*Duty Cycle = (+Width/period)(100)*

---

## User-defined $\Delta$ time

On the instrument, you may select the threshold level (lower/middle/upper), polarity of edge (either rise or fall), and the edge number. The measurement is then calculated as the time from the first source's edge to the second source's edge.

This gives flexibility in defining  $\Delta$ time measurements between channels or on a single channel between edges. To avoid confusing the delay measurement with time base delay and trigger delay, the delay measurement has been called  $\Delta$ time as shown in Figure 7-10. Refer to Chapter 10 for information on delay measurements.

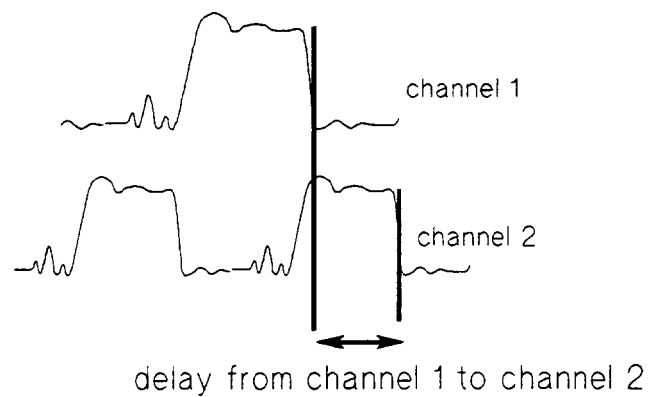

54720s11

**Figure 7-10. You may define  $\Delta$ time.**

---

### Some important measurement considerations

You may set the markers on the display to track the measurement results. This helps you verify the instrument is measuring the correct phenomena and aids in windowing the signal for measurement.

Statistics are available on the instrument, so you may display the mean, standard deviation, min, and max for each measurement result.

In the User Defined mode, you may also define some of the measurements you want to make. You may specify your own thresholds rather than using the standard 10, 50, and 90 percent or 20, 50, and 80 percent levels, specify the IEEE standard definitions of thresholds and measurements, or set thresholds in either voltage or percent. You may rely on the instrument to set top and base, or define those levels yourself in voltage. The  $\Delta$ time measurement is also under your control.

---

## Making Automatic Measurements



---

## Making Automatic Measurements

**What you'll find in this chapter**

This chapter describes the front panel Measure section, General Measure menu, Freq Domain menu, and Histogram menu.

The General Measure, Frequency Domain and Histogram functions are located in the Define Measure section of the front panel. To access these functions, press the blue **Shift** key and the desired function.



---

The instrument makes its measurements using the data showing on the display. It is, therefore, important that you correctly window the display to get accurate measurements. Windowing allows you to pick one pulse out of a series of pulses to make measurements on.

If more than one waveform, edge, or pulse is displayed, automatic measurements are made on the first (leftmost) portion of the displayed waveform that can be used.

When making measurements on non-symmetrical waveforms, expand the signal as necessary and move the baseline out of the window. This will avoid having the baseline selected as the top of the signal.

If the signal is clipped, the instrument cannot make some automatic measurements. You will get a warning or error message if this occurs.

---

## Period and frequency measurements

At least one full cycle of the waveform, with at least two like edges, must be displayed for period and frequency measurements.

Additionally, you can increase the accuracy of frequency measurements by windowing on multiple pulses. Automatic waveform measurements use a single pulse and may have significant errors introduced by interpolation and trigger inaccuracies. By placing marker 1 on edge 1 and marker 2 on edge 20, for example, you can get an average that negates errors that may be introduced in automatic measurements. This becomes even more important when using the deep memory feature of the instrument.

Set the markers to accomplish average frequency measurements from the front panel by using the  $\Delta$ time measurement in the Define Measure menu.

## Pulse width measurements

A complete positive pulse must be displayed to make a +Width measurement.

A complete negative pulse must be displayed to make a –Width measurement.

Remember, an edge must pass through *all three thresholds* to be recognized as an edge. Therefore, it is important the pulse be positioned so all three thresholds are displayed on the screen.

---

## Rise time, fall time, preshoot, and overshoot measurements

The leading (rising) edge of the waveform must be displayed for rise time and rising edge preshoot and overshoot measurements.

The trailing (falling) edge of the waveform must be displayed for fall time and falling edge preshoot and overshoot measurements.

Remember that an edge must pass through *all three thresholds* to be recognized as an edge. Therefore, it is important that the pulse be positioned so that all three thresholds are displayed on the screen.

Rise time, fall time, preshoot, and overshoot measurements will be more accurate if you expand the edge of the waveform by selecting a faster sweep speed. Expanding the waveform will provide more data points on the edge and thus a more accurate measurement.

For eye measurements, rise time and fall time should be measured in Color Grade mode.

---

## Front Panel Measure Section

The Agilent 83480A and Agilent 54750A can perform several common oscilloscope-type measurements, such as rise time, peak-to-peak voltage, and overshoot. In addition to making these measurements on simple repetitive pulse waveforms, the instrument can also make the measurement on more complex signals, such as an eye diagram. In many cases, the measurement algorithm for a two-level measurement, such as an eye diagram, is different than the algorithm used when measuring a pulse waveform. In most cases, the measurement is made on a color graded database. A basic discussion of the process of measurement is found in Chapter 7.

Before making signal measurements, it is important the instrument is correctly configured in terms of measurement definitions versus the signal type to be measured. This is typically achieved by using the Define Measure menu.

The following information lists the various utilities that are “single key” measurements. That is, the measurement has a dedicated key, typically a shifted function. Several other similar measurements also exist as submenus to the More Meas key. Measurement considerations and key paths are provided. In cases involving amplitude measurements, such as Vpp, the optical channels can display the equivalent power measurement, Ppp.

---

### $\Delta$ time

Used to measure the time between two user-defined points. Use Define Measure to define the edges and thresholds.

#### Key Path

(Shift)  $\Delta$ time

---

### **+width**

The time between the rising edge at the middle threshold and the falling edge at the middle threshold.

**Key Path**

**(Shift) +width**

---

### **-width**

The time between the falling edge at the middle threshold and the rising edge at the middle threshold.

**Key Path**

**(Shift) -width**

---

### **Duty Cycle**

The ratio of the +width to the period. When crossing points of an eye diagram are above the 50% threshold, duty cycle can exceed 100%.

**Key Path**

**(Shift) Duty cycle**

---

## Fall Time

Threshold levels (20% to 80%, 10% to 90%, or user-defined) are set in the Define Measure menu. The 20% to 80% thresholds are recommended for eye diagram analysis. Eye diagrams should be measured from the color graded database: **Display**, **Color grade**, on.

**Key Path**      **Shift** fall

---

## Frequency

Frequency is 1/period of the first detected edge to the next detected edge.

**Key Path**      **Shift** Frequency

---

## Overshoot

A histogram is used to characterize signal levels above Vtop. The 95% upper point of the histogram defines the overshoot level.

**Key Path**      **Shift** Overshoot

---

## Period

For a pulse, this is the measurement of the first detected edge to the next detected edge. Edges can be defined as rising or falling, through a defined threshold (middle). For an eye diagram measured with the color graded database, the period is the time between crossing points.

**Key Path**

**(Shift)** period

---

## Preshoot

The deviation from the Vbase signal prior to a rising edge.

**Key Path**

**(Shift)** Preshoot

---

## Rise Time

Threshold levels (20% to 80%, 10% to 90%, or user-defined) are set in the Define Measure menu. The 20% to 80% thresholds are recommended for eye diagram analysis. Eye diagrams should be measured from the color graded database: **(Display)**, **Color grade**, on.

**Key Path**

**(Shift)** rise

---

## Vamp

Measures the difference between Vtop and Vbase.

**Key Path**

**Shift** Vamp

---

## Vbase

Measures the most prevalent value of the lower portion of a pulse or eye diagram, for example, the mean value of the logical 0 in an eye diagram.

**Key Path**

**Shift** Vbase

---

## Vpp

Measures the separation between the maximum and minimum measured signals.

**Key Path**

**Shift** Vpp

---

## Vrms

Measures the rms of a waveform. It is only valid for a continuous repetition signal and not eye diagrams. It is not available with color graded database.

**Key Path**

(Shift) Vrms

---

## Vtop

Measures the most prevalent value of the upper portion of a pulse or eye diagram, for example, the mean value of the logical 1 of an eye diagram.

**Key Path**

(Shift) Vtop

---



---

## General Meas Menu

To access the General Meas menu press:

**Shift** **More Meas**  
**General Meas**

The measurements available include:

Tmax  
Tmin  
Vavg  
Vupper  
Vmiddle  
Vlower

**General Meas Menu**

---

## Tmax

The time at which the first Vmax sample occurs. For a histogram, it returns the peak value of the histogram.

**Key Path**

(Shift) (More Meas) General Meas Tmax

---

## Tmin

The time at which the first Vmin sample occurs. For a histogram, the minimum extreme of the histogram is returned.

**Key Path**

(Shift) (More Meas) General Meas Tmin

---

## Vavg

The average of the entire displayed waveform or a single period (selectable).

**Key Path**

(Shift) (More Meas) General Meas Vavg

---

---

## Vlower

Marks the level of the lower threshold as defined in Define Measure.

**Key Path**

**(Shift)** **(More Meas)** General Meas Vlower

---

## Vmiddle

Marks the level of the middle threshold as defined in Define Measure.

**Key Path**

**(Shift)** **(More Meas)** General Meas Vupper

---

## Vupper

Marks the level of the upper threshold as defined in Define Measure.

**Key Path**

**(Shift)** **(More Meas)** General Meas Vupper

---

## Avg Power Menu

To access the Avg Power menu, press:

(Shift) (More Meas)  
Avg Power

---

## Avg Power

Yields the average power of an optical signal measured on an optical channel derived directly from the dc component of the photocurrent.

### Key Path

(Shift) (More Meas) Avg Power

---

## Freq Domain Menu

To access the automatic FFT measurements, press:

**Shift** **More Meas**  
**Freq Domain**

The available FFT measurements are:

frequency  
magnitude  
delta frequency  
delta magnitude

---

### FFT freq

Returns the frequency value of a peak in the FFT spectrum as defined by peak number and peak threshold.

**Key Path**

**Shift** **More Meas** **Freq Domain** **FFT freq**

---

### FFT mag

Returns the magnitude value of a peak in the FFT spectrum as defined by peak number and peak threshold.

**Key Path**

**Shift** **More Meas** **Freq Domain** **FFT mag**

---

## FFT $\Delta$ freq

Returns the frequency difference between two peaks in the FFT spectrum as defined by peak numbers.

**Key Path**

(Shift) (More Meas) Freq Domain FFT  $\Delta$ freq

---

## FFT $\Delta$ mag

Returns the magnitude difference between two peaks in the FFT spectrum as defined by peak numbers.

**Key Path**

(Shift) (More Meas) Freq Domain FFT  $\Delta$ mag

After an FFT measurement is selected, a second level menu allows you to customize the measurement. The delta measurement menus allow you to select two peak numbers for the measurement.

---

## Source

Source selects the source for the measurement. The available sources are:

- channels
- functions
- memories
- FFT

### Key Path

**(Shift)** **(More Meas)** Freq Domain FFT Freq (or FFT Magnitude or  
FFT ΔFreq or FFT ΔMagnitude) Source

---

## Peak number

The Peak Number function selects which peak the instrument uses for the measurement. For example, a peak number of 2 indicates the measurement is made on the second peak from the left side of the screen.

The delta frequency and delta magnitude measurements have two peak selections. The delta magnitude measurement is performed by determining the magnitude of each of the two peaks and then subtracting the magnitude of the first peak from the magnitude of the second peak. The delta frequency measurement is performed by subtracting the frequency of the first peak from the frequency of the second peak.

### Key Path

**(Shift)** **(More Meas)** Freq Domain FFT Freq (or FFT Magnitude or  
FFT ΔFreq or FFT ΔMagnitude) Peak number

---

## Pk threshold

The Peak Threshold function sets the threshold level for peak searches. In order to be considered a peak, a local max in the FFT spectrum must be above the threshold level and must go up and down at least one-eighth of full scale (one division).

### Key Path

(Shift) (More Meas) Freq Domain FFT Freq (or FFT Magnitude or FFT ΔFreq or FFT ΔMagnitude) Pk threshold



---

## Histogram Menu

To access the Histogram menu, press:

**Shift** **More Meas**  
Histogram

### NOTE

Histogram measurements, under the More Meas key, require the Histogram function to be active in the Histogram menu.

---

$\mu \pm 1\sigma$

Returns the percentage of the total hits falling within  $\mu \pm 1\sigma$ .

**Key Path**

**Shift** **More Meas** Histogram  $\mu \pm 1\sigma$

---

$\mu \pm 2\sigma$

Returns the percentage of the total hits falling within  $\mu \pm 2\sigma$ .

**Key Path**

**Shift** **More Meas** Histogram  $\mu \pm 2\sigma$

## Histogram Menu

---

`$\mu \pm 3\sigma$`

Returns the percentage of the total hits falling within  $\mu \pm 3\sigma$ .

**Key Path**

`(Shift) (More Meas) Histogram  $\mu \pm 3\sigma$`

---

`hits`

Returns the number of samples that fall within the displayed histogram window.

**Key Path**

`(Shift) (More Meas) Histogram hits`

---

`mean`

Returns the most prevalent value of the histogram.

**Key Path**

`(Shift) (More Meas) Histogram mean`

---

## median

Returns the central value of the histogram.

**Key Path**

(Shift) (More Meas) Histogram median

---

## peak

Returns the number of hits occurring at the most prevalent value of the histogram.

**Key Path**

(Shift) (More Meas) Histogram peak

---

## pk-pk

Returns the peak to peak range of the histogram.

**Key Path**

(Shift) (More Meas) Histogram pk-pk

---

## Making Automatic Measurements

---

`std dev`

Returns the standard deviation of the histogram.

### Key Path

`(Shift) (More Meas) Histogram std dev`

Increasing Measurement  
Accuracy  
and Time-Interval  
Measurement

---

## Increasing Measurement Accuracy and Time-Interval Measurement

### **What you'll find in this chapter**

This chapter tells you how to obtain the highest accuracy available from the instrument. Though the examples refer to the Agilent 83480A and Agilent 54750A, most of the principles apply to any instrument.

The discussion is divided into four sections. The first section describes various methods for making time-interval measurements and the pros and cons of each. The second section introduces the concept of statistical analysis of time intervals. The third section explores errors in time-interval measurements that are not related to the time base accuracy, including the response of the instrument's vertical channels and the effect of probes.

This chapter also examines the distortions introduced by the vertical channels, the probes, and connecting cables, and it shows how these distortions affect the accuracy of time-interval measurements.

---

## Increasing Measurement Accuracy

---

---

### Measuring time intervals

In this section, we discuss measuring a pulse width to show the principles of time-interval measurement. The time interval you want to measure might be a setup time, a propagation delay, or a rise time. However, all time-interval measurements made with instruments are similar.

In all cases you measure the time between two events, where an event is defined as a voltage transition of a specified polarity through a specified level. When measuring the width of a pulse, these two events are the leading edge and the trailing edge. The concepts developed here can be applied to any other time-interval measurement. For two-channel measurements, you must take care to deskew the two channels. Refer to “Channel-to-channel measurements”, later in this chapter, for more information.

## Automatic measurements

Except in special cases, the simplest and most accurate way to measure the width of a pulse is to use the instrument's automatic measurement.

For the instrument to measure the pulse width automatically, the time/division control must be set so that the entire pulse, including the leading and trailing edges, is on the screen. Thus, the resolution of the measurement is limited by the time base resolution. In digitizing scopes, the time base resolution is primarily limited by memory depth and by the intrinsic hardware resolution of the fine interpolator in the time base.

It is important to select the optimum time/division scale to achieve the best resolution and accuracy. Both edges of the pulse must be on the screen, and at the same time, there must be sufficient baseline (or top for a negative pulse) for the top and base algorithm to reliably determine the voltage level of the base (or top). Refer to the discussion in "Calculating top and base" in Chapter 7, describing the algorithm the instrument uses to determine the top and base levels.

If the baseline is distorted prior to the initial transition of the pulse, enough of the "true" steady-state baseline must be present on the screen so that it will be identified clearly in a voltage histogram as the most prevalent value. The minimum time/division setting that achieves this will give the most accurate measurement. In other words, spread the pulse out to occupy as much of the screen as possible while allowing the base (or top for a negative pulse) to occupy at least 10 percent of the display (1 division).

The instrument allows you to select time/division settings other than the standard 1-2-5 sequence. For example, consider a pulse that is  $5.8 \mu\text{s}$  wide. At  $1 \mu\text{s}/\text{division}$ , the pulse will be 5.8 divisions wide, or 58 percent of the screen width. However, at  $500 \text{ ns}/\text{div}$ , the leading and trailing edges will not be on the screen simultaneously. Here, you could set the time base to  $650 \text{ ns}/\text{division}$ , and the pulse will occupy 90 percent of the screen.

The instrument has automatic measurements for all common pulse parameters. You can configure the Delay automatic measurement to measure any arbitrary time interval. Use the Define Measure menu to specify which interval the Delay automatic measurement will measure. You can store several custom delay measurement configurations using the Setup menu.



---

## Markers

You can measure a time interval manually using the markers in the instrument. One advantage of using markers is that you can expand the time base around the start and stop events of the time interval to be measured, thus achieving more time resolution than with automatic measurements (you are not limited by the memory depth). To see the difference, set up a pulse generator for a pulse width of 100 ns and a rise time of 1 ns (or as small as the pulse generator will allow). Then, measure the width both by using the instrument's automatic measurement and by using the markers.

---

## Channel-to-channel measurements

To make channel-to-channel measurements, such as propagation delay, setup time, or hold time, you must remove any systematic differences in the delays between the two acquisition channels and any associated probes or cables. This is accomplished with the Calibrate and Skew keys (refer to Chapter 4 in this manual).

---

## Statistics

To confidently predict the reliability of a digital system, you must know the statistics of its behavior. Singular measurements of setup time, hold time, propagation delay and skew do not allow you to adequately predict the probability of errors due to timing violations. However, a design based on worst-case measurements can be too conservative. A worst-case measurement does not show how frequently, or under what conditions, the worst case will occur.

### **Increasing Measurement Accuracy**

Measurement statistics in the instrument give valuable insight. To view statistics, select the Define Measure menu. The Statistics softkey allows you to display either the minimum and maximum or the mean and standard deviation of all selected measurements. The most recent value is always displayed.

You need to know how much the instrument's time-interval measurement varies statistically because this affects measurements of the statistical behavior of your system. Jitter introduced by the instrument has two components: a fixed part and a variable part. The fixed component of jitter is the same at all points on the time base, including the trigger point. The variable component increases as the delay from the trigger point increases.

To view the fixed part of the jitter, set the Position control in the Time Base menu to its minimum value. Set the Reference control in the Time Base menu to Center. Set up the instrument to view a fast-rising edge from a pulse generator, such as an Agilent 8131A. The triggered edge should be at the center of the screen. Press the Trigger menu key. You will see the trigger level marker displayed on the screen.

Ideally there would be no jitter (no horizontal spreading of the trace) where the waveform intersects the trigger level. Any spreading is the fixed part of the jitter.

To view the variable part of the jitter, you must have a synthesized, crystal-controlled signal source because the source must have less jitter than the instrument's time base. You can use these Agilent Technologies signal sources to characterize time base jitter:

- Agilent 8656B (see following paragraph)
- Agilent 8657A (see following paragraph)
- Agilent 3335A synthesized function generator
- Agilent 80000 pulse/pattern generator

The faster the slew rate of the source, the easier it is to evaluate jitter. One way to get fast-slewing edges is to trigger a pulse generator, such as an Agilent 8130A or Agilent 8131A, with a stable sine-wave source, like an Agilent 8656B or Agilent 8657A.

To see the variable jitter, set Position in the Time Base menu to a large number relative to the Scale setting. As you increase the value of Position, you will see the jitter increase. The instrument's variable jitter is on the order of 10 to 20 ppm, so you must use a large value of Position and a fast setting of Time Base Scale to see it. You can use the automatic measurements in the instrument to measure the jitter and observe its statistics. To calculate the slope of the variable jitter, subtract the fixed jitter from the observed jitter and divide by the Position setting.

The jitter in the instrument has approximately normal distribution. For measuring jitter that also has a normal distribution, the standard deviations add in quadrature as shown in equation 1.

**Equation 1**

$$(\textit{Measured jitter})^2 = (\textit{Signal jitter})^2 + (\textit{Scope jitter})^2$$

If the standard deviation of the instrument's jitter is 1/3 of the standard deviation of the actual jitter, the error in the measured standard deviation will be about 5 percent.

---

## Jitter and Averaging

Vertical averaging removes the apparent jitter on the display, but may give misleading information about the true behavior of the signal. For example, consider measuring rise time. Figure 9-1 shows a rise time measurement on a jittering signal with averaging turned on.

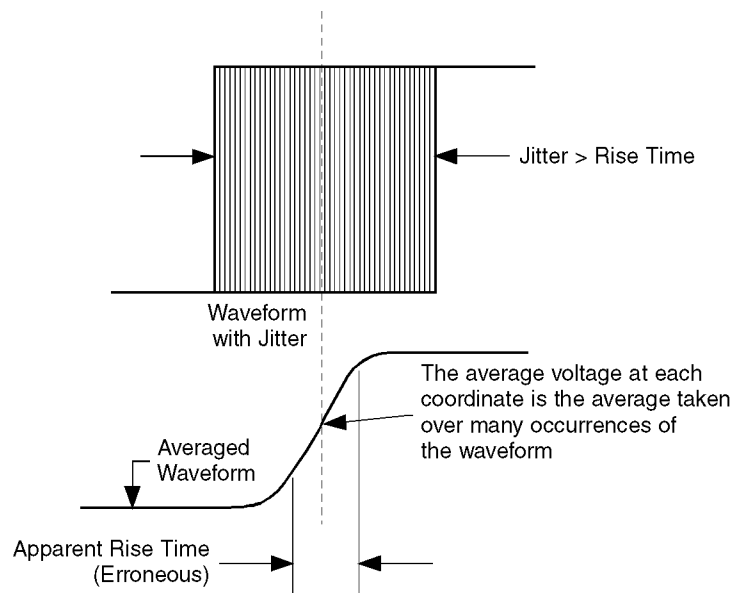

54720w10.CDR

**Figure 9-1. Erroneous rise time measurements due to jitter.**

---

## Time-Interval Measurements

Measuring time intervals with an instrument can be compared to measuring the length of a board with a ruler. However, the signal, unlike the board, is not directly accessible to the senses. Using an instrument is like taking a photograph of the board, then determining the board's dimensions by measuring the photograph. The instrument captures a record of the input signal, which is called the waveform. This waveform is not a perfect replica of the input signal, just as the photograph is not an undistorted replica of the board.

Errors introduced by the vertical channels of the instrument and by the probe can be divided into the following categories:

- dc errors. These include offset level error, gain error, vertical non-linearity, and vertical resolution limits.
- Dynamic response errors.

In general, the errors from the transient response of the vertical channels and probes are more significant than those from dc level errors in the vertical channels, especially for fast-slewing edges.

---

### dc errors

Time-interval measurements are referenced to the waveform crossing some voltage threshold. Therefore, any dc level errors cause errors in locating the times of features on the signal.

- Error term cancels if using relative (%) thresholds.
- Gain errors in the magnitude of the average slope of the transfer function.
- Linearity error variations in the slope of the transfer function.
- Random errors that can't be repeated from measurement to measurement.

**Time-Interval Measurements**

Figure 9-2 shows how vertical dc errors affect time-interval accuracy. The linearity of the instrument is typically better than 1/2 LSB, so the error is dominated by the offset and gain errors.

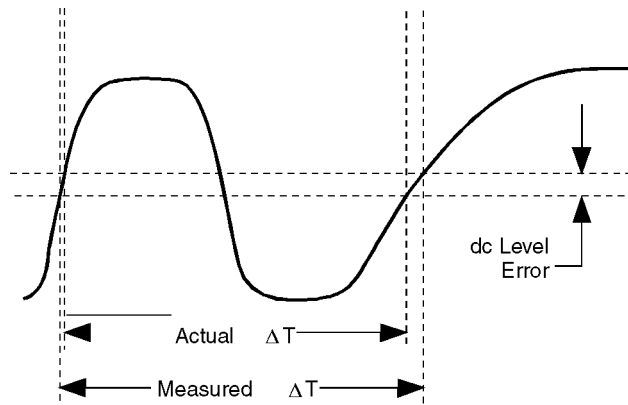

54720w11.CDR

**Figure 9-2. Effect of vertical dc errors on measurement accuracy.**

Time-interval errors due to voltage errors cancel when you measure the time between two edges having the same polarity, amplitude, offset, and slew rate at the same dc level on the same channel. Note that this rule applies only to single-channel measurements. For channel-to-channel measurements, the dc errors on each channel could be different, so the errors may not cancel.

If the slew rates of the edges are different as in Figure 9-2, there may still be a time error introduced by the dc level error, though both times are referenced to the same dc level and both edges have the same amplitude and polarity.

For time-interval measurements between edges of opposite polarity, the errors caused by dc level errors add rather than cancel as shown in Figure 9-3. The time errors in locating the leading edge and trailing edge of the pulse reinforce rather than cancel.

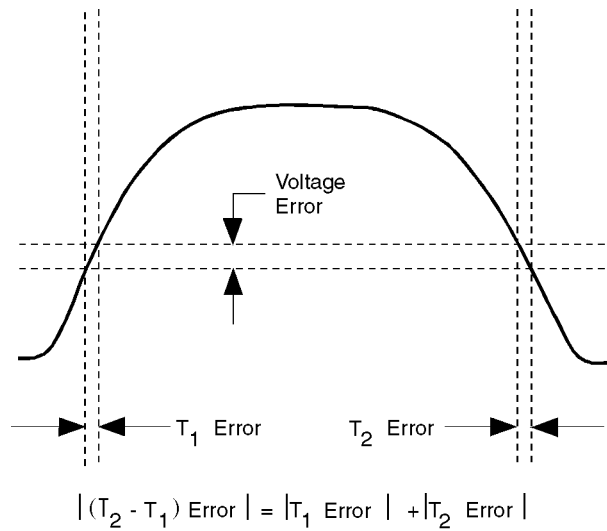

54720w12.CDR

**Figure 9-3. Edges of opposite polarity reinforce dc errors.**

**Time-Interval Measurements**

The faster the transition, the smaller the time error introduced by dc level errors. This is true both for edges of the same polarity and for edges of opposite polarity, as well as for channel-to-channel measurements, as illustrated by Figure 9-4. If the edges have a non-uniform slew rate with fast and slow regions, try to reference the time-interval measurement to the fastest-changing region as shown in Figure 9-5.

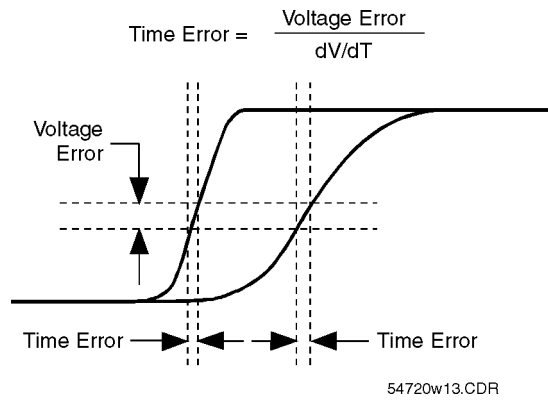

**Figure 9-4. Faster transitions decrease effect of dc offset errors.**

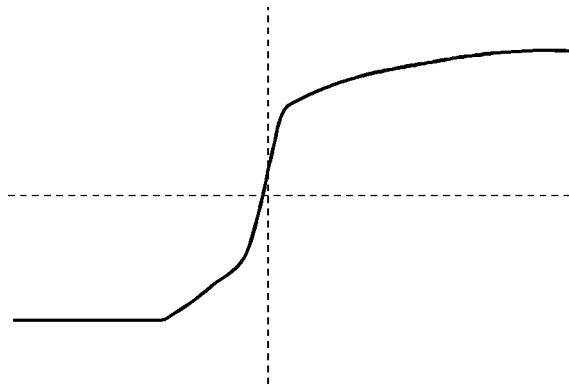

**Figure 9-5. Measure time intervals at fastest-changing part of transition.**



---

## Vertical quantization

The A/D converter in the instrument quantizes the waveform into discrete levels. The resolution of a time measurement cannot be any finer than the time it takes the input signal to pass through one quantization level (one LSB). This time will depend on the vertical resolution and the input slew rate.

With a resolution of 8 bits, a vertical scale factor is set to 100 mV/div, and an input slew rate of 1 V/s, the best timing resolution is 3.13 ns.

---

## Summary of dc errors

You can minimize the effects of dc errors on time-interval measurements by observing these guidelines when feasible:

- Measure between identical edges—same slew rate, amplitude, and offset.
- Use the same dc level to reference each endpoint of the interval.
- Reference the measurement to the fastest-slewing portion of each edge.
- Operate the instrument in a mode that gives the best vertical resolution.

Signal edges having faster slew rates minimize the effects of dc errors on the time interval measurement.

## Dynamic response errors

Whenever the input voltage of an instrument changes with respect to time, there is some transient error in the instrument's reproduction of the input signal.

The probe also has some non-ideal transient response that contributes to the overall system error. Additionally, the probe and the circuit under test form a circuit that behaves differently from the circuit without the probe; the signal at the probe tip is not the same as the signal that is present when the probe is removed. Probe loading often has a more significant effect on the measurement than the transient response of the instrument, and must be included in the analysis of time-interval measurement errors. See "Probe capacitive loading", later in this chapter, for more information.

At the very high bandwidth of the instrument, the transient response of  $50\Omega$  coaxial cables can be significant. You must use good quality cables and keep them as short as possible for best accuracy.

---

## Rise time response

If a step with a Gaussian shape is applied to the input of the instrument, the measured 10 percent to 90 percent rise time is approximately equal to the quadrature sum of the rise time of the step and the rise time of the instrument. The rise time of the instrument depends on which plug-in is used.

Consider measuring the rise time of a signal that has an actual rise time of 1 ns. If you use an instrument and probe that have a combined rise time of 1 ns, the error will be approximately 40 percent:

$$\text{Measured rise time} = \sqrt{(1 \text{ ns})^2 + (1 \text{ ns})^2} = 1.41 \text{ ns}$$

If instead you measure the same signal with an instrument and probe with a combined rise time of 330 ps, the error will be reduced to approximately 5 percent:

$$\text{Measured rise time} = \sqrt{(1 \text{ ns})^2 + (330 \text{ ps})^2} = 1.05 \text{ ns}$$

Table 9-1 shows the error for other ratios of instrument rise time to signal rise time.

**Table 9-1. Rise-Time Measurement Errors**

Signal Rise Time/ Instrument Rise Time	Measurement Error %
1	40
2	12
3	5
4	3
5	2
6	1.4
7	1

You can apply the concepts of rise time measurement to measuring the interval between two identical edges at different levels. The error in

### Time-Interval Measurements

measuring the interval from the 10 percent level on one edge to the 90 percent level on some later edge is the same as the error in measuring rise time.

**Narrow pulse response** If you apply a narrow pulse to the input of the instrument, the waveform is affected in three ways:

1. the height is incorrect
2. the 50 percent width is incorrect
3. the peak is shifted relative to the pulse as shown in Figure 9-6.

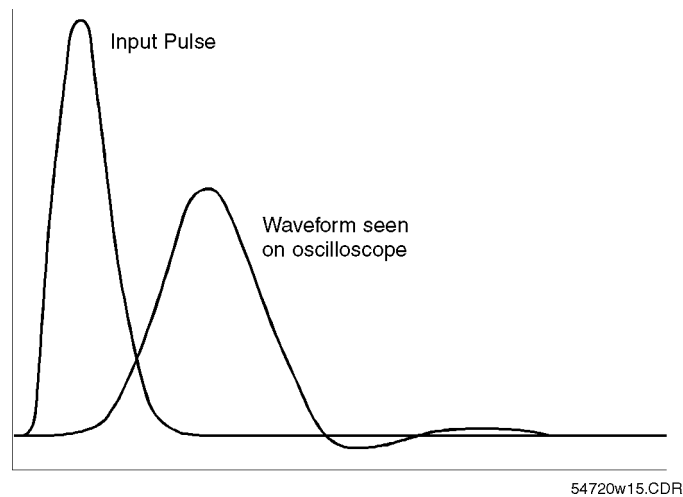

**Figure 9-6. Narrow pulse applied to the instrument.**

If this pulse is a glitch and you need to know whether it violates the logic threshold, the peak height error might make you believe that it does not. Figure 9-7 shows pulse height error as a function of instrument rise time and input pulse width.

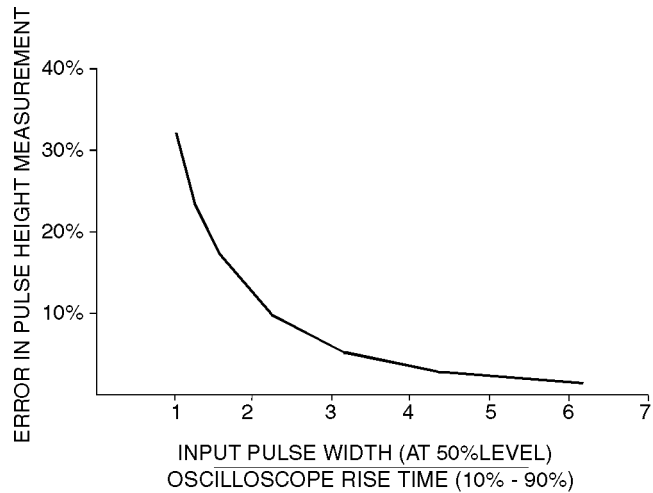

54720w16.CDR

**Figure 9-7. Errors in pulse height measurement.**

You can approximate the error in pulse width measurements by substituting “pulse width” for “rise time.” If a pulse has Gaussian shape and its width is greater than three times the instrument’s rise time, the error in the measured pulse width will be less than five percent, and the error in peak height measurements will also be less than five percent.

### Time-Interval Measurements

You can extend this concept to channel-to-channel time-interval measurements between edges of opposite polarity. Measuring the time interval between two closely spaced edges of opposite polarity on two channels is equivalent to measuring the width of a narrow pulse as shown in Figure 9-8.

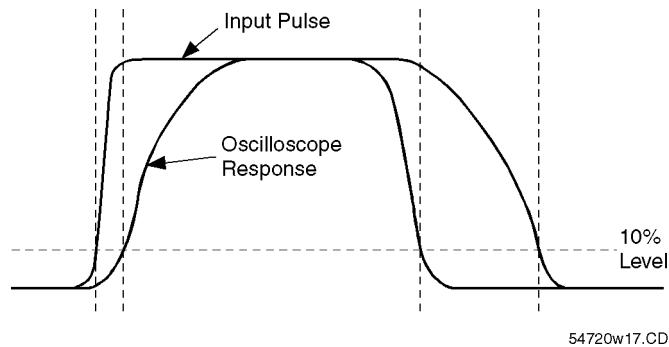

**Figure 9-8.**

**Error in pulse width at 10% level is approximately equal to the error in 10%–90% rise time.**

### Probe capacitive loading

The capacitance of the probe tip to ground forms an RC circuit with the output resistance of the circuit under test. The time constant of this RC circuit will slow the rise time of any transitions, increase the slew rate, and introduce delay in the actual time of transitions. The approximate rise time of a simple RC circuit is  $2.2RC$ . Thus, for an output resistance of 100  $\Omega$  and a probe tip capacitance of 8 pF, the real rise time at the node under test cannot be faster than approximately 1.8 ns. Without the probe, the rise time might be faster.

If the output of the circuit under test is current-limited, the slew rate is determined by equation 2. An example of this slew rate limit caused by the effect of probe capacitance is shown in Figure 9-9.

**Equation 2**

$$dV/dt = I/C$$

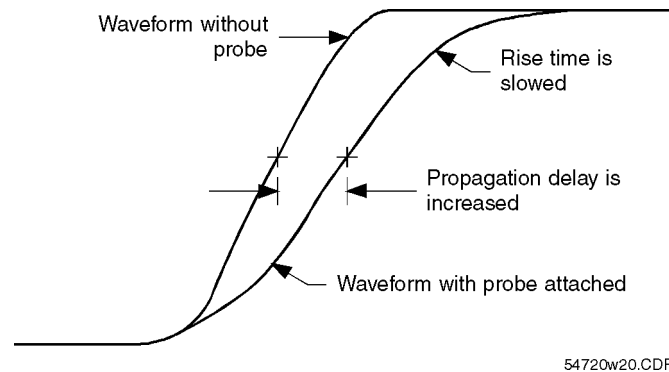

**Figure 9-9. Effect of probe capacitance.**

Perhaps you have connected an instrument to a circuit for troubleshooting, only to have the circuit operate correctly after connecting the probes. The capacitive loading of the probes can attenuate a glitch, remove ringing or overshoot, or slow an edge just enough that a setup or hold time violation no longer occurs.

**Summary**

Minimize the effects of transient response on time-interval measurements by following these guidelines.

- Choose an instrument and probe with a combined rise time of less than 1/3 the fastest rise time or pulse width to be measured.
- Consider probe loading effects, particularly capacitive loading. The RC time constant of the output impedance of the circuit under test and the capacitance of the probe should be very small compared to the signal rise time.

**Increasing Measurement Accuracy  
and Time-Interval Measurement**

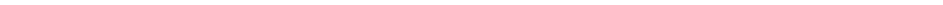



**General Purpose  
Oscilloscope Menus**

---

# General Purpose Oscilloscope Menus

**What you'll find in this chapter**

The front panel keys includes the following functions:

- Acquisition
- Channel Setup
- Define Measure
- FFT
- Histogram
- Math
- Time Base
- Trigger

This chapter describes each of these functions. They are listed alphabetically.

---

## Acquisition Menu

The Acquisition menu allows you to modify the way the instrument acquires the data by selecting the number of averages and record length.

---

## Averaging

With averaging active, the instrument averages the newly acquired data with the existing data before updating the display or measurements. The higher the number of averages, the less impact each new waveform will have on the composite averaged waveform.

To adjust the number of averages, press:

```
Acquisition  
Averaging on  
# of averages
```

Adjust the number of averages from 1 to 4096 using the knob, arrow keys, or keypad.

Averaging significantly reduces noise on the displayed waveform, improves resolution of the displayed waveform, and increases measurement repeatability, all due to a more stable, displayed waveform. However, averaging slows down the throughput of the instrument. Also, the waveform is less responsive to changes, especially when you select a high number of averages.

The vertical resolution can be improved to greater than 12 bits by using averaging.

The instrument uses this formula to calculate how to include new data with existing data.

$$\left[ \left( \frac{1}{n} \right) (new\ value) \right] + \left[ \left( \frac{n-1}{n} \right) (existing\ value) \right]$$

The Clear Display key resets the averaging process.

*In instruments with firmware revision A.02.00 and above, when averaging is on, acquired data is placed in the database used by the color grade, mask test and histogram features only after the specified number of averages is reached.*

Note that averaging is particularly useful for single-valued waveforms, such as pulses. Multi-valued waveforms, such as eye diagrams, are not improved with averaging because the eye “collapses” to the average value between a logic level one and logic level zero. Averaging can be used in conjunction with optional Eyeline software (available with the Agilent 83480A) to view eye diagrams for noise reduction and to view individual traces clearly.

**Key Path****Acquisition** Averaging

---

**Best**

*This function is only available in an Agilent 54750A, or an Agilent 83480A with the Agilent 54755A option installed.*

The samplers used in the Agilent 54750A and Agilent 83480A systems have a certain amount of passive feedthrough. This feedthrough is corrected by a compensation circuit. A small amount of feedthrough does remain after compensation and this causes slight non-flatness in a step response.

Since averaging implies single-valued waveforms, the Best function takes advantage of this to further improve flatness. This is done by taking a sample with the samplers turned on and then with the samplers turned off. The two results are then subtracted, thereby removing the residual non-flatness.

**Key Path****Acquisition** Averaging on Best

**Acquisition Menu**

---

## Record length...

Record length sets the memory depth for the waveform record. The choices for record length are automatic or manual.

**Key Path**

**Acquisition** Record length...

Automatic lets the instrument select the record length for you. The instrument picks a record length that optimizes the amount of data acquired and the display update rate. When the instrument is in the color graded display, waveform histogram, or mask testing modes, an optimum number of points for the database is selected. It is recommended that the auto record length be used for the above three modes. The number of points in a complete record length is displayed with the Record Length key.

**Key Path**

**Acquisition** Record length... **Mode** Automatic

Manual lets you pick a record length from 16 to 4096 points. Use the knob, arrow keys, or keypad to select a record length.

Because more data points need to be acquired, a waveform with a long record length takes longer to construct than one with a short record length. However, a long record length produces a waveform with higher horizontal resolution, therefore a tradeoff exists between throughput and resolution. The automatic setting attempts to maximize both throughput and resolution.

**Key Path**

**Acquisition** Record length... **Mode** Manual

---

## Channel Setup Menu

This section describes the Channel Setup menu.

---

### CAUTION

The input circuits can be damaged by electrostatic discharge (ESD). Therefore, avoid applying static discharges to the front-panel input connectors. Before connecting any coaxial cable to the connectors, momentarily short the center and outer conductors of the cable together. Avoid touching the front-panel input connectors without first touching the frame of the instrument. Be sure the instrument is properly earth-grounded to prevent buildup of static charge. For more information regarding ESD, refer to the front of this manual.

---

The Channel Setup menu is accessed from the front-panel Channel key of the appropriate plug-in module. There is a separate key for each channel. Modules with two channels have two keys, modules with one channel have one key. Most menu functions only operate on the selected channel. Some softkeys, such as Cal Status, access functions that apply to the entire module. These functions can be accessed from either Channel key.

The functions available depend on the specific plug-in module. Refer to the user's guide of the plug-in module for a complete description of the channel setup features.

The Channel Setup menu can include the following features:

- Display on/off
- Vertical scale
- Vertical offset
- Channel bandwidth
- Bessel-Thompson filter on/off
- Channel autoscale
- External attenuation factors
- Probe calibration
- Channel skew
- Module calibration status

---

## Define Measure Menu

The Define Measure menu sets the measurement points (thresholds) where the automatic measurements are made. The menu influences the measurement algorithm by allowing you to use the standard IEEE measurement points, or by allowing you to customize the measurements with the user-defined selections.

Figure 10-1 is a waveform drawing that shows some of the standard measurement thresholds.

Refer to Chapter 7 for details about the algorithms used to calculate the thresholds for the automatic measurement features.

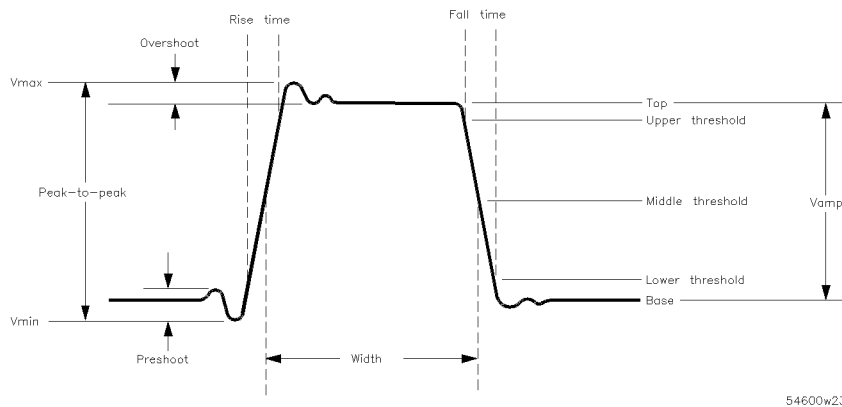

**Figure 10-1. Standard measurement thresholds.**



---

## Thresholds...

The Thresholds menu sets the measurement points that the automatic measurements use for calculating the timing measurement results. The threshold points are lower, middle, and upper. For example, rise time is measured from the lower threshold to the upper threshold, while a width measurement is made between two middle thresholds. The three threshold choices are the standard IEEE measurement points 10%, 50%, 90%, or 20%, 50%, 80%, or user defined. The Upper, Middle, and Lower softkeys are displayed when user defined is selected.

**Key Path**

**Define meas** Thresholds ...

10%, 50%, 90%

20%, 50%, 80%

These are the two standard pulse measurement thresholds for all measurements. These standard thresholds are calculated as a percentage of the top-base values, and the top-base values are calculated from the waveform that is on the display. Make sure that the waveform is expanded vertically and horizontally so that the instrument can accurately determine the top and base values of the waveform. However, if too much of the top and base of the waveform is on the display, it may reduce the number of sample points on the edge of interest, which may reduce the repeatability of your measurements. A good rule of thumb is to have two divisions of top and two divisions of base.

When the instrument cannot make the requested measurement, an error message is displayed instead of a measurement result. Usually, this is because there are not enough sample points, an edge is not on the display, or the specified channel is turned off.

When the measurement result is followed by a question mark, this indicates that the waveform is clipped high or low, two points were not available for linear interpolation, or the amplitude of the waveform is too small.

**Key Path**

**Define meas** Thresholds... 10% 50% 90%

**Define meas** Thresholds... 20% 50% 80%

## Define Measure Menu

### user defined

You can set the unit of measure for the upper, middle, and lower thresholds to either % (percent) or Volts. Percent is calculated from the top-base values, and you can set the percent values from  $-25$  percent to  $+125$  percent in  $0.1$  percent increments. Volts lets you set the thresholds to particular voltage values regardless of the top-base values. You can set the voltage values from  $-1.00$  GV to  $+1.00$  GV in increments determined by the voltage range you are in. For example, if the upper threshold is set to  $110 \mu\text{V}$ , you can change the threshold in  $1 \mu\text{V}$  increments. However, if the threshold is set to  $110$  MV, you can change the threshold in  $1$  MV increments.

The upper threshold value is always greater than the value of the middle threshold, and the middle threshold value is always greater than the value of the lower threshold. The instrument will not allow a threshold to cross over the adjacent threshold.

If the threshold you are using for the measurement is not positioned on the waveform, then a **Thresholds?** error message is displayed in place of the automatic measurement result.

When Units is set to Volts, user defined simplifies the threshold detection algorithm. The result is that the measurement throughput of the instrument is increased, because the instrument does not have to calculate the voltage thresholds.

### Key Path

Define meas Thresholds... user defined

**Using markers to show the threshold setting**

1. To use the markers to show the threshold setting, press:

```

(Shift), (More Meas)
General Meas
Vupper
Enter

```

2. Select the channel, function, or memory you are measuring by pressing:

```

channel, function, or memory
Enter

```

3. Define the upper threshold level by pressing:

```

(Define meas)
Thresholds
user defined
Upper

```

Adjust the upper value. The marker gives you a visual indication of where the upper value is positioned on the waveform.

4. Use the same procedure to adjust the middle and lower threshold values.

If the marker value is much greater than the threshold value, the marker may be clipped off the screen.

---

## Top-base

The Top-base function sets the vertical reference thresholds for amplitude measurements. It also sets the values from which the upper, middle and lower thresholds are calculated. The Top and Base softkeys are displayed when the User Defined function is selected.

**Key Path**

```

(Define meas) Top-base

```

**Define Measure Menu**

---

## Standard

The Standard function has the instrument calculate the top-base using the IEEE standards with a voltage histogram of the waveform that is on the display. The instrument finds the most prevalent top and base voltage values.

Make sure there is enough of the signal displayed on the screen so that the instrument can accurately determine the top and base values of the waveform. However, if too much of the top and base of the waveform are on the display, it may reduce the number of sample points on the edge of interest which may reduce the repeatability of your measurements. A good rule of thumb is to have two divisions of top and two divisions of base.

**Key Path**

Define meas Top-base standard

---

## User Defined

User defined lets you set the top and base to a specific voltage value. The upper, middle, and lower thresholds are then calculated from the voltage values you select.

User defined simplifies the threshold detection algorithm. The result is that the measurement throughput of the instrument is increased, because the instrument does not have to calculate the top-base values.

### Key Path

**Define meas** Top-base user defined

### Using markers to show top-base settings

The markers can be used to give you a visual indication of where you are manually setting the top-base values on a waveform.

1. To use the markers to show the top-base settings, press:

**Markers**  
measurement  
Enter  
**Shift** **V amptd**  
Enter

2. Select the channel you are using.
3. Adjust the Top and Base levels by pressing:

**Define meas**  
Top-base  
user defined

Adjust the values of Top and Base. The markers give you a visual indication of where you are positioning them on the waveform.

If the marker values are much greater than the top-base values, the markers may be clipped off the screen.

## Define Measure Menu

---

### Define $\Delta$ time

The Define  $\Delta$ time function sets up the parameters for all automatic  $\Delta$ time measurements. The sources for the  $\Delta$ time measurement are not selected in this menu.

#### Key Path

**Define meas** **Define  $\Delta$ time**

#### Selecting automatic $\Delta$ time measurements

To select automatic  $\Delta$ time measurements, press:

**Shift**,  **$\Delta$ time**

---

### Start Edge or Stop Edge

You can set the start edge or the stop edge to rising, falling, or either. The selection effects all  $\Delta$ time measurements.

#### Key Path

**Define meas** **Define  $\Delta$ time** **Start edge**

---

## Edge Number

You can set the Start Edge number or Stop Edge number from 1 to 65,534. The selection affects all  $\Delta$ time measurements.

The automatic measurements are made on waveforms that are on the display. If you select an edge that is not on the display, the message **Edge?** is displayed instead of the measurement results. To get a  $\Delta$ time measurement, you must either select an edge that is already on the display or reduce the time base scale setting so the selected edge is on the display.

### Key Path

**Define meas** **Define  $\Delta$ time** **Edge number**

---

## Edge Threshold

You select both a Start Edge threshold and a Stop Edge threshold. The Edge threshold choices are upper, middle, or lower. You set the threshold values in the Thresholds menu described earlier in this chapter. The selection affects all  $\Delta$ time measurements.

### Key Path

**Define meas** **Define  $\Delta$ time** **Edge threshold**

**Define Measure Menu**

---

## Color grade...

*This function available with firmware revision A.02.00 and above.*

The Color Grade function accesses a sub-menu that allows you to define various parameters used in measuring color-graded signals. These include signal type, eye window, and measurement completion functions.

**Key Path**

**Define meas** Color grade...

---

## Signal type

*This function available with firmware revision A.02.00 and above.*

The Signal Type function defines the waveform types to be measured by the instrument. Measurement algorithms vary depending on the type of signal being measured. For example, the algorithm used to determine rise time for an NRZ eye diagram is different from the algorithm used to measure the rise time on a single-valued pulse waveform.

You can select:

pulse                    for general pulse measurements

NRZ                      for non-return to zero data

AMI                      for alternate mark inversion

CMI                      for coded mark inversion

The default waveform type is NRZ.

**Key Path**

**Define meas** Color grade... Signal type



**NOTE**

When selecting a standard mask from the Standard Mask menu of the Agilent 83480A, the correct color grade signal type is automatically selected.

---

## Eye window 1 and Eye window 2

The Eye Window function is used to define the portion of a bit over which an eye diagram will be characterized using automatic eye measurements. Refer to Chapter 6 for additional information on making automatic eye measurements.

Eye window 1 defines one boundary of the eye and Eye window 2 defines the second boundary. Values are entered as a percentage of bit width. For example, if extinction ratio is to be characterized over a complete bit interval, one window boundary should be set to 0%, and the other window boundary is set to 100%. If the middle 20% of the eye is to be characterized, one window boundary should be set to 40%, and the other window boundary is set to 60%.

For certain eye measurements, when markers are set to measurement, Marker X1 is set to Eye window 1 and Marker X2 is set to Eye window 2.

Regardless of the values of Eye window 1 and Eye window 2, the window is the area between them.

**Key Path**

**Define meas** Color grade... Eye window 1

**Define meas** Color grade... Eye window 2

**Define Measure Menu**

---

## Meas Complete

*This function available with firmware revision A.02.00 and above.*

This function is used to define the amount of data that must be in the color grade display database for a color grade measurement to complete. Active measurements will not report values until this amount of data has been acquired. The value specified is the peak number of hits the database must contain. The current peak number of hits may be determined by looking at the Color grade menu under Display. A range of numbers is shown next to each color. The peak number of hits is the largest value listed at the top.

**Key Path**

Define meas Color grade... Meas complete

---

## Statistics

The Statistics function calculates the mean and standard deviation and the minimum and maximum of the automatic measurement results. The statistics results are displayed below the lower right portion of the graticule area. This is the same area where the marker results are displayed. If the marker results are displayed instead of the statistics results, either turn off the manual and waveform markers or turn off the readout for the measurement markers.

When you turn statistics on, the mean, standard deviation, minimum, and maximum values start to accumulate at the same time. All results are continuously updated, even though only one pair of results is currently displayed. For example, if you select minimum and maximum, the minimum and maximum values are displayed on the screen and they are updated as the results change. The mean and standard deviation results are also calculated and continuously updated, even though they are not displayed on the screen. As the statistics accumulate, you can switch between displaying the minimum and maximum values, or the mean and standard deviation values.

**Key Path**

Define meas Statistics

**Statistics results reset conditions.**

The statistics results are reset or restarted under the following conditions:

- Selecting the measurement.
- Turning on the display of the signal under measurement.
- Changing any of the thresholds in the Define Measure menu.
- Changing the time base window, scale, position, reference, or resolution (number of points).
- Changing the channel state, scale, or offset.
- Changing the trigger definition.
- Redefining the waveform math function, if the measurement is calculated on a function.
- Switching the filter in or out on an optical channel.
- Storing to memory, if the measurement is calculated on a memory.
- Clearing the display.

---

**Off**

The Off function stops the statistics measurements, resets the results, and erases the statistics measurement results from the display.

**Key Path**

**Define meas** **Statistics** off

**Define Measure Menu**

---

**mean, stddev**

Mean and stddev (standard deviation) calculates the mean and standard deviation of the automatic measurement results. Mean is the statistical average of all results for a particular measurement. Standard deviation measures the dispersion of those measurement results.

Figure 10-2 shows the mean and standard deviation more graphically. Standard deviation is represented by the Greek letter sigma ( $\sigma$ ). For a Gaussian distribution, two sigma ( $\pm 1 \sigma$  from the mean) is where 67 percent of the data points reside, and six sigma ( $\pm 3 \sigma$  from the mean) is where 99.7 percent of the data points reside.

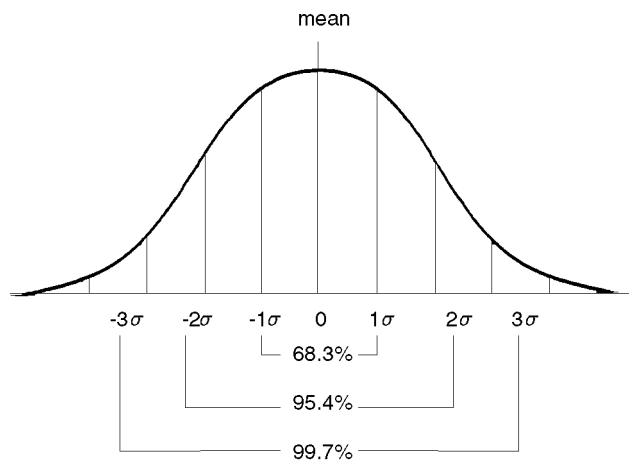

54700b11.cdr

**Figure 10-2. Standard deviations of a Gaussian distribution.**

**Key Path**

**Define meas** **Statistics** mean, stddev

The mean is calculated as:

$$\mu_n = \frac{\sum x}{n}; (1 \leq n \leq 65, 534)$$

$$\mu_n = \frac{\mu_{n-1}(n-1) + x}{n}; n = 65, 535$$

Where:

$\mu$  = mean

$n$  = count since last statistics reset

$x$  = measurement result

Standard deviation is calculated as:

$$\sigma = \left[ \frac{n \sum x^2 - (\sum x)^2}{n(n-1)} \right]^{\frac{1}{2}}; (2 \leq n \leq 65, 534)$$

$$\mu_n^2 = \frac{\mu_{n-1}^2(n-1) + x^2}{n}; n = 65, 535$$

$$\sigma = \left[ \frac{n[\mu_n^2 - (\mu_n)^2]}{n-1} \right]^{\frac{1}{2}}; n = 65, 535$$

Where:

$\sigma$  = standard deviation

$n$  = count since last statistics reset

$x$  = measurement result

## **min, max**

Min (minimum) and max (maximum) are the absolute extremes of the automatic measurement.

### **Key Path**

**Define meas** **Statistics** min, max

---

## FFT Menu

The Agilent 83480A and Agilent 54750A display signals in the time domain. When an FFT, or fast Fourier transform is added to an instrument, signals can also be displayed in the frequency domain. The frequency domain allows you to see the frequency content of a signal. FFT functionality added to an instrument allows you to analyze a signal from two different but complimentary points of view: the frequency domain and the time domain.

---

## Display

The Display function turns the FFT function on and off. When on, the FFT Scaling softkey is displayed and a new waveform is displayed on the screen corresponding to the FFT function. This FFT waveform is displayed in the same color used to represent waveforms on slot 3. The default color is purple.

**Key Path****FFT** Display

---

## Source

The Source function determines which signal the instrument uses to generate the FFT function. As the source of the FFT function, you can select:

- channels
- functions
- memories
- constant

**Key Path****FFT** Source

---

## Window

The three FFT windows you can select from are:

- rectangular
- Hanning
- flattop

The FFT operation assumes the time record repeats infinitely. Unless there is an integral number of cycles of the sampled waveform in the record, a discontinuity is created at the end of the record. This is referred to as leakage. In order to minimize spectral leakage, windows that approach zero smoothly at the beginning and end of the record are employed as filters to the FFT.

Windows work by weighting points in the middle of the waveform record higher than those at the ends of the record. For example, a Hanning window looks like the first half of a sine wave. The Hanning window multiplies the points in the center of the record by 1 and multiplies the points at the start and the end of the record by zero.

The rectangular window is essentially no window. All points in the record are multiplied by 1. The rectangular window is useful for transient signals and signals where there are an integral number of cycles in the time record.

The Hanning window is useful for frequency resolution and general-purpose use. It is good for resolving two frequencies that are close together or for making frequency measurements.

The flattop window is the best window for making accurate amplitude measurements of frequency peaks.

### Key Path

**(FFT)** Window



---

## FFT Scaling

The FFT Scaling softkey is displayed when the FFT Display is turned on. Pressing the FFT Scaling softkey brings up either the Magnify, Y-Scale or Y-Offset menu.

### Key Path

**FFT** **Display** **On** **FFT Scaling**

---

## Magnify

The Magnify function allows you to zoom in on a portion of the FFT record. Use off to view the entire FFT spectrum, and use on to view a portion of the spectrum.

The Magnify softkey affects which two keys are displayed below it. When magnify is off, the Span and Resolution softkeys are displayed. When Magnify is on, the Magnify Span and Center Freq softkeys are displayed. The Magnify Span and Center Freq softkeys use software expansion to rescale the FFT.

**Key Path**      **FFT** **Display** **On** **FFT Scaling** **Magnify** **On**

**Magnify Span**      The Magnify Span softkey is displayed when Magnify is set to on. The Magnify Span softkey uses software expansion to zoom in on the FFT record. The span is entered in steps of 1, 2, and 5. You can also enter any magnification spans from the keypad.

**Key Path**      **FFT** **Display** **On** **FFT Scaling** **Magnify** **On** **Magnify span**

**Center Freq**      The Center Freq softkey is displayed when Magnify is set to on. The Center Freq softkey uses software expansion to center the frequency record to the desired frequency.

**Key Path**      **FFT** **Display** **On** **FFT Scaling** **Magnify** **On** **Center freq**

---

## Y-Scale

The Y-Scale function uses software expansion to set the vertical scaling of the FFT function. It does not affect the hardware settings in the plug-ins. The scaling units are in dB per division. For example, if the scale is set to 10 dB/div, and a peak is two divisions high, you know that the amplitude of the frequency peak is 20 dB.

### Key Path

**FFT** Display On FFT Scaling Y-Scale

---

## Y-Offset

The Y-Offset function uses software expansion to move the FFT function vertically on the screen. Offset is the value at the center of the graticule area. If you adjust the offset so that a peak is at the vertical center of the graticule area, then you know that the peak magnitude is the offset value. For example, if the peak of the spike is at the vertical center of the graticule area and the offset reading is  $-16.2$  dBm, then you know that the peak magnitude is  $-16.2$  dBm.

### Key Path

**FFT** Display On FFT Scaling Y-Offset

---

## Other FFT measurements

There are a number of time domain measurements that you can make on FFT waveforms:

- Tmin
- Tmax
- Vp-p
- Vmin
- Vmax

The Tmax measurement is particularly useful because it returns the frequency of the highest peak on the display.

---

## FFT basics

The Fourier series states that any waveform that repeats in time can be represented by a dc term plus a series of cosine and sine waves. The Fourier series was developed in 1807 by the French mathematician, Jean Baptiste Fourier, to solve thermodynamics problems. A more general form of the Fourier series, called the Fourier transform, was developed later. It allows any time domain signal, whether it is periodic or single shot, to be transformed into the frequency domain. The fast Fourier transform (FFT) was developed as a special algorithm that speeds up the discrete Fourier transform (DFT) by reducing the large number of calculations that are required by DFTs. Because an FFT runs 10 to 100 times faster than the traditional DFT, Fourier transform calculations typically use FFTs in place of DFTs.

Oscilloscopes operate in the time domain and display waveforms with the vertical axis representing amplitude and the horizontal axis representing time. Because FFTs are frequency domain functions, the horizontal axis on the display changes to represent frequency when you select FFTs.

Figure 10-3 illustrates what an FFT does. An FFT transforms a time record of N samples into a frequency record of N points from 0 Hz to Fs, where Fs is

the sample frequency. The resolution or the spacing between the points in the frequency record is  $F_s/N$ .

The frequency  $F_s/2$  is a unique frequency referred to as the Nyquist frequency. At the Nyquist frequency there are exactly two samples on every cycle of the input signal. Signals above the Nyquist frequency become aliased which means that they appear as signals of a lower frequency. The reason is that there are not enough sample points on each cycle of the signal to determine the correct frequency.

It turns out that the points above  $F_s/2$  are a mirror image of the points below  $F_s/2$ . The points above  $F_s/2$  are not displayed because they do not provide any additional information. Therefore,  $N$  time samples results in  $N/2$  displayed frequency points.

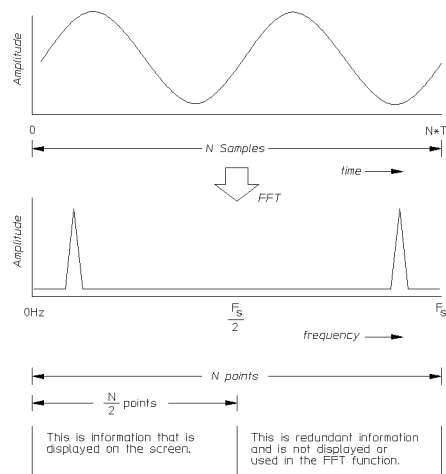

54720w02

**Figure 10-3. Sine wave in the frequency domain.**

Figure 10-4 shows an example. The upper graticule shows a 1 GHz waveform in the time domain, and the lower graticule shows the same signal in the frequency domain. By looking at the Magnify Span and Center Freq softkeys, you can determine the display setup and see there is strong signal content at 1 GHz, as well as odd frequency multiples (3 GHz, 5 GHz, and so on).

**FFT Menu**

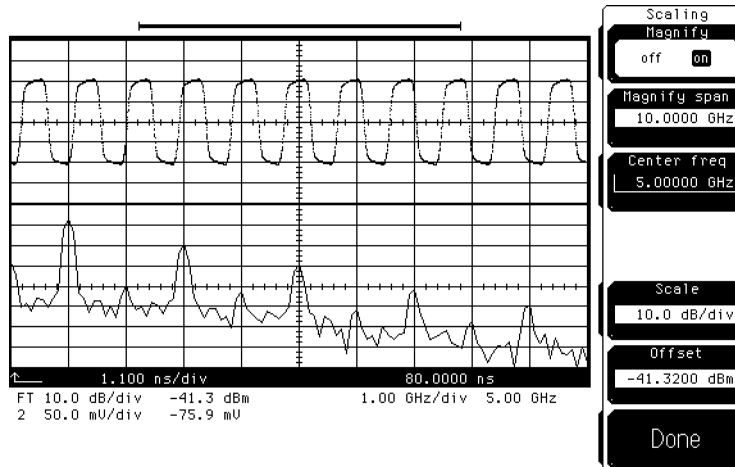

**Figure 10-4. An FFT display.**

You may also notice that there are three horizontal lines of numbers below the graticule area. The first line lists the horizontal scale and position settings of the time domain. The second line lists the vertical and horizontal settings of the FFT. It is labeled “FT” for Fourier transform. The third line lists the vertical scale and offset settings of channel 2.

Because the frequency domain may be new to you, let’s look at the second line of numbers. The first number is the vertical scale in dB/div. The second number is the offset in dBm at the center of the lower graticule area. The third number is the horizontal scale in frequency/div. The fourth number is the center frequency value.

To maximize the use of the display area, some of the instrument’s features share the lower area of the display. The vertical settings and automatic measurement results share the same area of the display; the marker results, statistics results, and the horizontal settings of the frequency domain share the same area of the display.

---

## Frequency measurements

**For best frequency accuracy on peaks**

1. In the Channel menu, set the Scaling for almost full scale deflection.
2. Set the Span so that the signal of interest is near the horizontal center of the screen (not down at dc), but high enough to avoid aliasing. The left edge of the screen is 0 Hz, or dc.
3. Select the Hanning window

A higher number of points results in more accurate measurements, but also takes more computation time. Depending on your application, you can balance between the need for accuracy and computation speed of the FFT.

---

## Frequency accuracy

The frequency accuracy is the sum of two terms. The first term is supplied because there are a limited number of frequency bins, and the measurement is accurate to plus or minus half a bin. The second term is related to the accuracy of the internal oscillator which generates the sample clock.

$$accuracy = \pm \left( \frac{frequency\ resolution}{2} + 0.007\% \times signal\ frequency \right)$$

---

## Amplitude measurements

**For best amplitude accuracy on peaks**

1. In the Channel menu, make sure the source impedance and probe attenuation are set correctly for your application.
2. In the Channel menu, set the Scaling for almost full scale deflection.
3. In the FFT menu, use the flattop window
4. Press **Shift** **More meas** on the keypad, then make an FFT magnitude measurement.



---

## Computation of dBm

The vertical units of the FFT functions are dBm, and 0 dBm is defined as a 1 mW signal. The formula for converting a signal of power P into dBm is:

$$dBm = 10 \log \left( \frac{P}{1 \text{ mW}} \right)$$

A handier formula, and the one that is used in the instrument, is for calculating dBm from the peak voltage.

$$dBm = 20 \log \left( \frac{V_p}{0.316228 \text{ V}} \right)$$

The bottom term, 0.316228 volts, is the peak voltage of a 1 mW signal into a 50Ω resistor. The calculation is:

$$V_p = \frac{V_{rms}}{0.707107} = \frac{\sqrt{P \times R}}{0.707107} = \frac{\sqrt{1 \text{ mW} \times 50\Omega}}{0.707107} = 0.316228 \text{ V}$$

If you are measuring the power of a signal, then terminate the source into 50Ω in order to get the correct dBm reading. However, if you are measuring voltage, then you do not need to terminate source impedance into 50Ω. The equation above for dBm as a function of peak voltage still applies.

---

## Computation of dBV

Another common unit of amplitude is dBV. A 0 dBV signal is defined as a 1 Vrms signal. You can convert a dBm reading to a dBV reading by subtracting 13 dB.

$$dBV = 20 \log \left( \frac{0.707107 \times V_p}{1 V} \right)$$

Which gives us:

$$dBV = 20 \log \left( \frac{V_p}{0.316228 V} \right) + 20 \log \left( \frac{0.707107 \times 0.316228 V}{1V} \right)$$

Therefore:

$$dBV = dBm \text{ value} - 13.01 \text{ dB}$$

---

## dc value

For efficiency reasons, the FFT computation produces a dc value that is incorrect.

---

## Aliasing

When using FFTs, it is important to avoid aliasing. Aliasing occurs when there are insufficient samples on each cycle of the input signal to recognize the signal. Aliasing occurs whenever the frequency of the input signal is greater than or equal to the Nyquist frequency (effective sample frequency divided by 2).

When a signal is aliased, it shows up in the FFT spectrum as a signal of a lower frequency. Because the frequency span goes from 0 to the Nyquist frequency, the best way to prevent aliasing is to make sure that the frequency span is greater than the frequencies present in the input signal. Keep in mind that most periodic signals that are not sine waves have frequency components that are much higher than the frequency of the signal.

---

## Presetting FFT parameters

The FFT vertical parameters, Magnify, Magnify span, and Center frequency are set to the default values whenever the operand (or operator, if the FFT magnitude operator is selected from the Math menu) is changed.

---

## Histogram Menu

A histogram is a probability distribution that shows the distribution of acquired data within a user-definable, histogram window. You can display the histogram either vertically for voltage measurements or horizontally for timing measurements.

The two most common uses for histograms are measuring and characterizing noise or jitter on displayed waveforms. Noise is measured by sizing the histogram window to a narrow portion of time and observing a vertical histogram that measures the noise on an edge. Jitter is measured by sizing the histogram window to a narrow portion of voltage and observing a horizontal histogram that measures the jitter on an edge. Several histogram based measurement routines have been automated and consolidated as part of the Measure Eye menu. To display the Histogram menu, press **Histogram**. Refer to “Measure Eye Menu” in Chapter 6 for more information.

---

## Histograms in the instrument

The instrument has three features that use a specific database. This data base uses a different memory area than the waveform record for each channel. The three features that use the database are histograms, mask testing, and color graded display. When any one of these three features are turned on, the instrument starts building the database. The database is the size of the graticule area, which is 256 pixels high by 451 pixels wide. Behind each pixel is a 16-bit counter. When color graded display, mask testing, or histograms are turned on, a database is built by incrementing the 16-bit counters each time a pixel is hit by data from a channel or function. The maximum count (saturation) for each counter is 65,535. You can check to see if any of the counters are close to saturation by going to the Display menu and turning on the Color Graded Display feature. The Color Graded Display menu uses colors to represent the number of hits on various areas of the display.

The database continues to build until the instrument stops acquiring data or all three functions (color graded display, mask testing, and histograms) are turned off. The instrument stops acquiring data when:

- the power is cycled.
- the Stop/Single key is pressed.
- the Run Until Mode softkey in the mask, limit test, or histograms menus is set to stop acquiring data after a specified number of waveforms or samples are acquired.

You can clear the database by pressing the Clear Display key, cycling the power, or turning off all three features that use the database. The database does not differentiate waveforms from different channels or functions. If three channels are turned on and the waveform from each channel happens to light the same pixel at the same time, the counter is incremented by three. However, it is not possible to tell how many hits came from each waveform. You can separate waveforms by setting the display to two graphs or by positioning the waveforms vertically with the channel offset. By separating the waveforms you can avoid overlapping data in the database caused by multiple waveforms. Even if the display is set to show only the most recent acquisition, the database keeps track of all pixel hits while the database is building.

Color graded display, mask testing, and histograms all use the same data base, and turning on any one of them starts building the data base. Suppose

## Histogram Menu

that the database is building because color graded display is turned on. When mask testing or histograms are turned on, they take advantage of the information already established in the database as if they had been turned on the entire time. Figure 10-5 shows an example histogram.

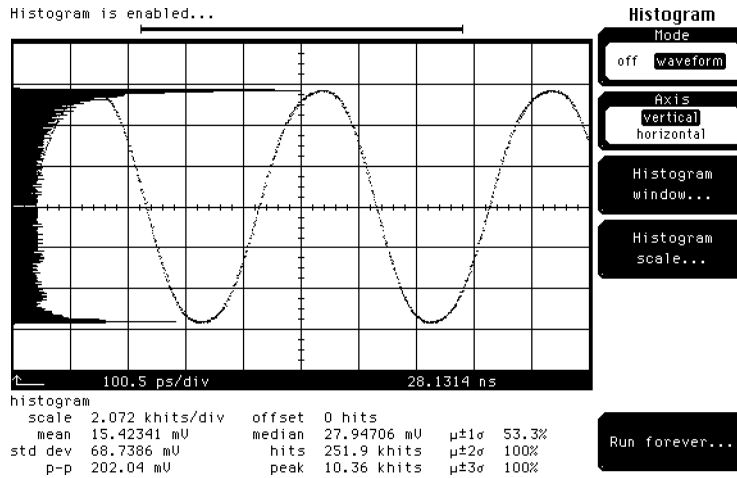

Figure 10-5. An example of the histogram display.

You may notice the following histogram statistics listed below the graticule area.

Scale	Scale lists the display scale in hits per division or dB per division.
Offset	Offset lists the offset in hits or dB. Offset is the number of hits or dB at the bottom of the display, as opposed to the center of the display.
Mean	Mean is the average value of all the points in the histogram.
Median	50% of the histogram samples are above the median and 50% are below the median.
Std dev	The Standard deviation ( $\sigma$ ) value of the histogram.
Hits	The total number of samples included in the histogram.
P-P	The width of the histogram. For horizontal histograms, width is the difference time between the first and last pixel columns that contains data. For vertical histograms, width is the difference in time between the first and last pixel rows that contain data.
Peak	The number of hits in the histogram's greatest peak.
$\mu \pm 1\sigma$	The percentage of points that are within $\pm 1\sigma$ of the mean value.
$\mu \pm 2\sigma$	The percentage of points that are within $\pm 2\sigma$ of the mean value.
$\mu \pm 3\sigma$	The percentage of points that are within $\pm 3\sigma$ of the mean value.

## Histogram Menu

---

### Mode

The Mode function turns the display of the histogram off and on.

The Off selection turns off the display of the histogram, while the Waveform selection turns on the display of the histogram. If the database for the histogram is not already built (mask testing and color graded display turned off), Waveform starts building the database and the histogram. If the database is already built, the Waveform function displays a histogram of the data in the database that is windowed by the histogram markers. The database can be reset by pressing the Clear Display key.

#### Key Path

**Histogram** Mode

#### Waveform

The Waveform function displays a histogram of the data in the database that is windowed by the histogram markers.

#### Key Path

**Histogram** Mode waveform

---

### Axis

The Axis function orients the histogram vertically or horizontally. Vertical places the histogram at the left side of the graticule, which allows for voltage measurements. Horizontal places the histogram at the bottom of the graticule area, which allows for timing measurements.

#### Key Path

**Histogram** Mode waveform Axis



---

## Histogram Window

The Histogram Window softkey gives you access to a second-level menu that allows you to select a region of the database to include in the histogram.

### Key Path

**Histogram** Mode waveform Hist window

### Scale Source

The Scale Source softkey selects the channel or function that the window scale is derived from. For example, if Y1 position is set to 100  $\mu$ W and Y2 position is set to 0  $\mu$ W, the distance between the histogram markers depends on the vertical scaling of the source. If the source is set to 50  $\mu$ W/div, the markers will be two divisions apart. If the source is set to 500  $\mu$ W/div, the markers will be about a minor division apart.

### Key Path

**Histogram** Mode waveform Hist window Scale source

## Histogram Menu

### X and Y Position

The Position softkeys allow you to use the histogram markers to select a region of the database. X1 and X2 position move the vertical histogram markers vertically across the display, while Y1 and Y2 position move the horizontal histogram markers horizontally across the display. Because the database that the histogram is derived from is limited to the size of the graticule area, placing the histogram markers beyond the graticule area results in a histogram of only the graticule area.

For manual jitter measurements, you would position the Y1 and Y2 histogram markers so that the histogram is built from a very narrow horizontal slice of the graticule area. For noise measurements, you would position the X1 and X2 histogram markers so that the histogram is built from a very narrow vertical slice of the graticule area.

### Key Path

<b>Histogram</b>	Mode	waveform	Hist window	X1 Position	or
<b>Histogram</b>	Mode	waveform	Hist window	Y1 Position	or
<b>Histogram</b>	Mode	waveform	Hist window	X2 Position	or
<b>Histogram</b>	Mode	waveform	Hist window	Y2 Position	

---

## Histogram Scale

The Histogram Scale softkey gives you access to a second-level menu that allows you to set the scale of the histogram.

### Key Path

**Histogram** Mode waveform **Hist scale**

### Scale Type

Linear sets the display of the histogram results to the number of hits per division, while logarithmic sets the display of the histogram results to dB.

#### Linear scale

For linear scale type, the scale is in the percentage of the peak per division. For example, on a horizontal histogram, 20% places one-fifth of the histogram in each of eight divisions with the top of the peak (100%) at the middle of the display.

#### Log scale

For log scale type, the scale is in decibels per division. The histogram is plotted according to the following formula.

$$dB = 20 \log \left( \frac{X}{peak} \right),$$

where:

*X* is the number of hits in a histogram row for vertical histograms, or the number of hits in a histogram column for horizontal histograms.

*Peak* is the number of hits in the largest histogram column or row.

*dB* is the log value that gets plotted.

## Histogram Menu

### Linear offset

For linear scale type, the offset is the percentage of the peak at the left edge or lower edge of the display. For example, on a horizontal histogram, an offset of 20% places 20% of the peak at the lower edge of the display. Therefore, 20% of the histogram will be below the display, and the other 80% of the histogram will be above the lower edge of the display (displayed on the screen).

### Log offset

For log scale type, the offset is in decibels at the left edge or lower edge of the display. The histogram is plotted according to the following formula.

$$dB = 20 \log \left( \frac{X}{peak} \right),$$

where:

*X* is the number of hits per column for horizontal histograms, or the number of hits per row for vertical histograms.

*Peak* is the number of hits in the peak.

*dB* is the log value that gets plotted.

This means 0 dB is at the peak of the histogram and the offset can only contain negative values. For example, with a horizontal histogram, an offset of -20 dB places 10% or  $10^{(-20/20)}$  of the peak at the lower edge of the display.

### Key Path

**Histogram** Mode waveform Hist scale linear or

**Histogram** Mode waveform Hist scale logarithmic

**Scale Mode**

The Scale Mode softkey determines how much of the histogram is displayed on the screen. If the Axis softkey is set to horizontal, auto sets the base of the histogram to the bottom of the graticule area and displays the histogram using half of the graticule height.

If the Axis softkey is set to vertical, auto sets the base of the histogram to the left edge of the graticule area and displays the histogram using half of the graticule width.

Manual lets you window in on the histogram by allowing you to change the scale and offset settings. Depending on the setting of the Scale Type softkey, the scale value is in either percent of peak per division or dB. By changing the scale, you can zoom in or out on the histogram. Offset allows you to pan across the histogram by moving the base of the histogram. Depending on the setting of the Scale Type softkey, the offset value is also in either percent of peak or dB per division.

**Key Path**

**Histogram** Mode waveform Hist scale Scale mode

---

**Run Until**

The Run Until softkey allows you to determine when the acquisition of data stops. If forever is selected, you must press the Stop/Single key to stop the acquisition of data. If either waveforms or samples is selected, after the number of waveforms or samples are met the acquisition is stopped.

**Key Path**

**Histogram** Mode waveform Run until

---

## Math Menu

The Math menu allows you to define either one or two functions. Each function consists of a math operator and either one or two operands. A function is calculated on data adjusted by the calibration factors, and a new waveform (called a function) is generated by the computation. You can place markers on functions, make measurements on functions, or store functions to waveform memories.

---

## Function

Allows you to select either function one (f1) or function two (f2). You can display both functions on the screen at the same time. Even though a channel display is set to off, you can still use that channel as part of a function and see the results of the function on the display.

**Key Path**      **(Math)** Function

---

## Define Function

You can select a math operator for the function, and the waveform source for the operand or operands.

**Key Path**      **(Math)** Define Function

**Operator**      You can select any of the math functions as the math operator to act on the operand or operands. To see the resultant waveform, simply turn the Function display on.

**Key Path**      **(Math)** Define Function Operator

**magnify**      Magnifies the waveform on operand 1. This allows different vertical and horizontal scales to be shown similar to the time base windowing feature.

*Function scaling replaces scale and offset when this key is selected.*

**Key Path**      **(Math)** Define Function Operator magnify

**Math Menu**

**invert**

Inverts the waveform on operand 1.

**Key Path**

**Math** Define Function Operator invert

**add**

Adds, point by point, operand 1 and operand 2.

**Key Path**

**Math** Define Function Operator add

**subtract**

Subtracts, point by point, operand 2 from operand 1. Use subtract to make a differential measurement.

**Key Path**

**Math** Define Function Operator subtract

**multiply**

Multiplies, point by point, operand 1 and operand 2. Use multiply to make electrical power measurements.

**Key Path**

**Math** Define Function Operator multiply

**divide**

Divides, point by point, operand 1 by operand 2.

**Key Path**

**Math** Define Function Operator divide

**versus**

Draws a volts versus volts display of the two selected operands. The bandwidth of both the X and Y axis is the full bandwidth of the instrument's vertical input.

*Function scaling replaces scale and offset when this key is selected.*

**Key Path**

**Math** Define Function Operator versus



**integrate** Calculates the integral of operand 1. Use integrate to calculate the energy of a pulse in volt-seconds.

**Key Path** **(Math)** Define Function Operator **integrate**

**differentiate** Calculates the discrete derivative of operand 1.

**Key Path** **(Math)** Define Function Operator **differentiate**

**min** Minimum stores the minimum value acquired in each time bucket on operand 1.

**Key Path** **(Math)** Define Function Operator **min**

**max** Maximum stores the maximum value acquired in each time bucket on operand 1.

The results for minimum and maximum are recalculated when any of the following occurs:

- Time base scale, position, or reference is changed.
- Channel state, scale, or offset is changed.
- Trigger definition is changed.
- Record length is changed.
- Additional data is stored to a waveform memory that is used as part of a function.
- The instrument is turned off and on.
- The Clear Display key is pressed.

**Key Path** **(Math)** Define Function Operator **max**

## Math Menu

### FFT Magnitude

Generates a new waveform by using a fast Fourier transform (FFT). Refer to the FFT Menu, earlier in this chapter, for a detailed description of the FFT features and functions.

*Function scaling replaces scale and offset when this key is selected.*

### Key Path

**Math** Define Function Operator FFT magnitude

### bw limit

The variable bandwidth limit filter is a fourth order low pass Bessel filter.

### Key Path

**Math** Define Function Operator bw limit

### Operand

The math operator is performed either on operand 1, or on operand 1 and operand 2. The number of operands used depends on the math operator you select. For example, add requires two operands while invert requires only one operand.

Operand lets you select from channels, functions, waveform memories, or a constant.

- If the operand waveforms have different record lengths, the function uses the shortest record.
- If two operands have the same time base scale, the resulting function has the same time scale which results in the proper time scale for the function.
- Constant operands have the same time scale as the associated waveform operand.
- A waveform function operand is acquired even if its display is turned off.
- Function 1 is allowed as an operand for function 2. This allows you to construct equations with up to two operators and three operands.

### Key Path

**Math** Define Function Operand 1

---

## Display

When you set the display to on, the softkey menu displayed depends on which math operator you select. When magnify, versus, or FFT magnitude is the operator, the Function Scaling softkey replaces the Vertical softkey. You can then manually manipulate the scale and offset settings used to display the new waveform.

The Display softkey turns on the display of the function, and it allows you to adjust the size and position of the newly generated waveform (function) for easily viewing the waveform and for easily making measurements. You can use the knob, arrow keys, or keypad to size and position the function. Software expansion is used to resize the function when you change the display controls. It does not change the way the hardware acquires the data.

When display is set to on, the function is calculated and displayed. Turning the display to off ends function computation and erases the function from the display.

Function 1 is displayed in the same color that is used to display signals from slot 1, and function 2 is displayed in the same color that is used to display signals from slot 2.

**Key Path****(Math)** Display**Scale***This function is only available when FFT magnitude is selected.*

Scale changes the vertical size of the function, so that it is not clipped or too small on the display.

**Key Path****(Math)** Display On Function scaling Scale**Offset***This function is only available when FFT magnitude is selected.*

Offset positions the function vertically on the display.

**Key Path****(Math)** Display On Function scaling Offset

**Math Menu**

**Function scaling**

*This function is only available when Magnify, Versus or FFT Magnitude is selected.*

When Magnify, Versus or FFT Magnitude is the selected, the Function Scaling softkey replaces the Vertical softkey. When you select Function Scaling, a second level softkey menu allows you to change the vertical and horizontal scaling of the function.

Refer to the FFT Menu, earlier in this chapter, for a description of the FFT scaling functions.

**Key Path**

**Math** **Display On Function scaling**

**Vertical**

*This function is only available when Magnify or Versus is selected.*

Vertical allows you to select either track source or manual. Track source makes the function use the same vertical scale and offset of the function's waveform source. Manual allows you to set the vertical scale and offset independently of the waveform source. Increased resolution in scale and offset can be achieved.

**Key Path**

**Math** **Display On Function scaling Vertical**

**Horizontal**

*This function is only available when Magnify or Versus is selected.*

Horizontal allows you to select either track source or manual. Track source allows the function to use the same horizontal scale and position as the waveform source. Manual allows you to set the horizontal scale and position of the function independently of the settings for the waveform source.

**Key Path**

**Math** **Display On Function scaling Horizontal**

---

## Time Base Menu

This section contains a description of the Time Base menu and how it controls the horizontal portion of the display. The topics covered are horizontal scale, position, reference, and windowing.

**Time Base Menu**

---

## Units

*This function is only available with the Agilent 83480A, or if the Agilent 83480K option is installed in an Agilent 54750A.*

The Units function lets you set the instrument timebase to basic time units or to bit period units. Bit period units provide an easy and intuitive way to display digital communication signals. Instead of having to compute the time interval required to display two bits or eyes, you can simply set the scale to two bits. Refer to the Scale softkey, earlier in this chapter.

**Key Path**

Time Base Units

---

## Bit rate

*This function is only available with the Agilent 83480A, or if the Agilent 83480K option is installed in an Agilent 54750A.*

Bit rate allows the time base to be configured for a variety of standard optical and electrical telecommunications rates. If you are measuring a signal with one of these standard rates, the scale and position functions will coincide with this rate.

**Key Path**

Time Base Units Bit rate

---

## Scale

The Scale function changes the sweep speed from 10 ps/div to 1 s/div. If bit period has been selected for the time base units, scale is measured in bits. You can change the sweep speed with the knob, keypad, or arrow keys. The knob and arrow keys operate in two modes. One mode is a 1-2-5 step sequence, while the other mode is a fine mode that allows smaller incremental changes. The keypad allows you to enter more precise values than are possible with either the knob or arrow keys.

In the bit period mode, the knob and arrow keys scroll between standard rates for digital communications signals. To select a non-standard rate, enter the rate from the numeric keypad. To enter values in Mb/s, enter the number followed by **(Eex)** **(6)**. To enter values in Gb/s, enter the number followed by **(Eex)** **(9)**.

When the instrument is stopped, and you expand the scale, the instrument redisplay the signal at the new scale setting. This feature allows you to zoom in or to zoom out on the signal. If you watch the memory bar at the top of the display, you can see what portion of memory you are zooming on.

### Key Path

**(Time Base)** **Scale**

---

## Position

The Position function moves the sweep horizontally.

When the instrument is stopped, position allows you to pan across a signal. The memory bar at the top of the display indicates the portion of memory you are panning across.

The minimum position level is 22 ns, or the equivalent number of bits, depending on the bit rate selected.

### Key Path

**(Time Base)** **Position**

---

## Reference

The Reference function places the reference point to the left side or the center of the display. The Reference function defines the point at which the position is referenced. For example, if the reference is Left, then the position refers to the left of the display, whereas Center references the position to the center of the display. The reference also defines the expansion point for the time base scale control.

### Center reference

The data is acquired evenly on both sides of the reference point. The data in the waveform record is centered around the reference point, and changing the scale expands or contracts the signal about the center of the display.

### Left reference

The data is acquired starting at the Position value, and changing the scale expands or contracts the signal about the left edge of the display.

### Key Path

**Time Base** Reference



---

## Time base windowing

The Time Base Windowing function is similar to the delayed sweep on analog oscilloscopes because it turns on an expanded time base. This expanded time base allows you to pinpoint and to horizontally expand a portion of the signal for a more detailed or high resolution analysis. It can also help you to make custom automatic measurements. Automatic measurements are made on the first occurrence of the event on the display. The windowing feature allows you to isolate individual events on the display for the automatic measurement.

### View

View lets you select main or window.

**Main**. The Main function displays the signal according to the scale and position settings, and a window marker is placed on the signal. The window marker defines the portion of the signal you plan to expand. However, the color highlight is not available when mask testing is turned on. The default color of the window marker is red, but you can change the window marker color in the Display menu.

**Window**. The Window function expands and displays the portion of the signal that is outlined by the window marker. The amount of expansion depends on the window scale and window position settings.

### Time base

**Window Scale**. The Window Scale function controls the length of the window marker, and the maximum window scale setting is 100% of full screen. The window marker determines how much of the signal is expanded in the window mode. Increasing the window scale decreases the amount of expansion.

### Key Path

**(Time Base)** Time base windowing **Enable** Window Scale

**Time Base Menu**

**Window Position**. The Window Position function moves the intensified marker horizontally across the main sweep. It allows you to precisely pick the segment of the main sweep you wish to expand for further analysis.

**Key Path**

**Time Base** Time base windowing Enable Window Position

---

## Trigger Menu

This section describes the Trigger menu, and explains how you can use its controls to trigger the instrument. The trigger circuit performs two functions. It locates the waveform of interest, and it synchronizes the instrument measurement and display to the waveform.

## Trigger Menu

---

### Trigger basics

A trigger event is defined as an edge of a selected slope (either positive or negative) that transitions through a selected voltage (trigger level).

The trigger circuit and sampler circuit operate in parallel. The sampler samples the input signal at a specific rate. The trigger circuit operates independently of the sampler circuit, and a trigger event does not have to occur at the same time as a sample point. Because the instrument knows when the trigger event happened in relation to the sampled data, the instrument knows where to place the sampled data on the display.

There are three green LEDs at the top left corner of the mainframe.

When a LED is lit, it indicates the trigger status of the instrument.

Armed	The instrument is waiting for a trigger event to occur.
Triggered	The instrument triggered on a valid trigger event.
Freerun	The instrument is automatically triggered as soon as it is armed. This is useful for seeing a waveform untriggered or for looking at a baseline.

*Agilent 83480A Option 100 only:* When in the 12 GHz mode, the triggered and freerun lights are illuminated at all times to reflect the operation of the 12 GHz trigger.

Refer to the user's guide for the plug-in you are using for details on the trigger specifications.

---

### Sweep

The Sweep function lets you select between the Triggered and Free Run modes.

#### Key Path

Trigger Sweep

**Triggered**

The instrument displays data only after all of the trigger conditions are met. The Triggered mode keeps the instrument from triggering and displaying data on the screen before a specific trigger event occurs. Each time the instrument triggers, it lights the Triggered LED. Then, the trigger circuit is rearmed for the next trigger event.

**Key Path**

**Trigger** Sweep triggered

**Free Run**

This mode forces the instrument to trigger when armed, giving you glimpses of the signal, which then allows you to set up channel vertical scales to display signals.

**Key Path**

**Trigger** Sweep freerun

---

**Source**

The Source function displays a list of the available trigger sources. The list of available trigger sources depends on the combination of plug-ins you are using.

Changing trigger sources while the instrument is running causes newly acquired data to overwrite existing waveforms that are on the display. However, if the instrument is stopped, changing trigger sources does not change the display until the instrument starts running again.

**Key Path**

**Trigger** Source

**Trigger Menu**

---

## External Scale

The External Scale function can be used when the trigger signal level changes due to the use of an attenuator or a probe. The attenuator factor can be entered either as a decibel value or a ratio.

**Key Path**

**Trigger** External Scale

---

## Level

Level specifies the voltage threshold that a signal must cross in order for the instrument to trigger on that signal. You can use the knob, arrow keys, or keypad to change the trigger level. You can adjust the trigger level from within any of the trigger submenus.

The trigger level setting also determines what the instrument uses as a reference to determine a high or low. A high is a voltage above the trigger level, and a low is a voltage below the trigger level.

**Key Path**

**Trigger** level

---

## Slope

Slope specifies whether the instrument triggers on either the positive or negative edge on a signal. A positive slope is an edge that transitions through and above the trigger level. A negative slope transitions through and below the trigger level.

**Key Path**

**Trigger** Slope

---

## Hysteresis

The Hysteresis function defines the amount of hysteresis around the trigger point. Selections include normal and high sensitivity.

**Key Path**

**Trigger** Hysteresis

---

## Trig Bandwidth

The Trig Bandwidth function brings up a second-level softkey menu on the display. The Trig Bandwidth menu allows you to select the trigger mode. For more information regarding trigger bandwidth, refer to Chapter 13.

**Key Path**

**Trigger** Trig Bandwidth

## General Purpose Oscilloscope Menus

### 2-12 GHz

The 2-12 GHz function allows direct triggering on 12 GHz signals. This trigger bandwidth mode can *not* be used when the Agilent 83480A is performing eyeline measurements. Use the **DC-2.5 GHz** mode instead. *This function is available on the Agilent 83480A Option 100 only.*

#### Key Path

**Trigger** Trig Bandwidth 2-12 GHz

### 2-12 GHz Gate

The 2-12 GHz Gate function allows use of an external gating signal to extend triggering capability. This trigger bandwidth mode can *not* be used when the Agilent 83480A is performing eyeline measurements. Use the **DC-2.5 GHz** mode instead. *This function is available on the Agilent 83480A Option 100 only.*

#### Key Path

**Trigger** Trig Bandwidth 2-12 GHz Gate

### DC-2.5 GHz

The DC-2.5 GHz function provides direct triggering on 2.5 GHz signals.

#### Key Path

**Trigger** Trig Bandwidth DC-2.5 GHz

### DC-100 MHz

The DC-100 MHz function limits the trigger bandwidth by applying a low pass filter.

#### Key Path

**Trigger** Trig Bandwidth DC-100 MHz



**— The General Function  
Menus**

---

## The General Function Menus

**What you'll find in this chapter**

This chapter describes the following menus:

- Disk
- Display
- Limit Test
- Marker
- Setup
- Setup Print
- Utility
- Waveform

---

## Disk Menu

The instrument has a high density, 3-1/2 inch, MS-DOS<sup>®</sup> compatible disk drive. In the Disk menu you can save and recall waveforms, save and recall front-panel setups, delete files from a disk, format a disk, or obtain a directory listing of a disk.

In other menus you can use the disk drive to load applications, load new system firmware, or save a copy of the display information in a TIFF, GIF, PCX, or printer specific format.

You can choose from five different disk operations: directory, load, store, delete, and format.

**Disk Menu**

---

## directory

When you select directory from the list of disk operations, a screen similar to Figure 11-1 is displayed.

Directory gives you a listing of the files on a disk, including file name, type, size, date, time, and the available space left on the disk.

When you press the **(Disk)** key to enter the Disk menu, the instrument checks to see if a disk is in the drive. If there is a disk in the drive, you will see a directory listing of all the files on the disk. If there is no disk in the drive, the screen displays the message "There is no disk in the drive." Then, the Disk softkey menu is displayed.

**Key Path**

**(Disk)** Operation **directory**

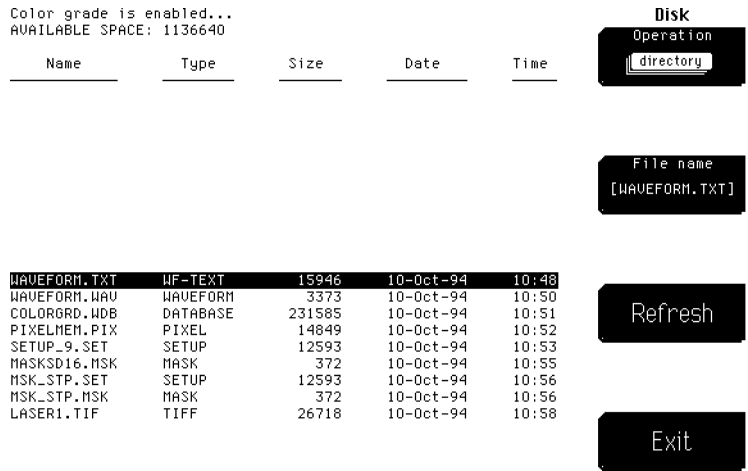

Figure 11-1. The Directory display.

To update the directory listing or get a new directory listing, press:

**Disk**  
**Operation**  
**directory**  
**Enter**  
**Refresh**

Use the Refresh function when:

- You just pressed the Disk key without a disk in the drive. However, now there is a disk in the drive and you want to see a listing of the files on the disk.
- You just put a new disk in the drive, and you need to see a listing of the files on the new disk.

If the type of file is not recognized by the instrument, the type field is left blank. Also, the instrument lists only those files that are in the root directory of the disk. All other directories on the disk are listed like files, except that a file extension is not appended to the filename and the file size is listed as 0 bytes. Any files that are not in the root directory are not included in the directory listing. There is no way to change to a subdirectory or access files in a subdirectory.

**NOTE**

Refer to "Type", later in this chapter, for more information on file types.

**Disk Menu**

---

**load**

The Load function allows you to select from six file types: waveform, color graded database, pixel memory, setup, mask, or program. You can bring only these six file types back into the instrument from the disk drive.

When you select a file type, only those files the instrument recognizes as that file type are listed on the screen. Files are loaded from the root directory only.

Use the knob, arrow keys, or keypad to scroll through the directory listing of the disk; or press the From File softkey to enter a file name. Pressing the From File softkey displays another softkey menu that allows you to enter a file name. A file extension is not needed because the file extension is determined by the type of file and format you selected.

Waveform and waveform text files are loaded into one of the four waveform memories by overwriting any data previously stored in that waveform memory. Color grade files are read directly into the instrument by overwriting the previous color grade. Pixel files are loaded in the pixel memory by overwriting any data previously stored in the pixel memory. Setup files are immediately activated as the new front-panel setup by overwriting the previous front-panel setup. A Mask file is loaded into the instrument by overwriting the previous mask.

**Key Path**

**Disk** **Operation** **load**

**NOTE**

To avoid overwriting the database being loaded into the instrument from the disk, make sure the instrument is in the stopped mode. Otherwise, the instrument will continue to acquire data and will add information to the database.

**TDR/TDT cals***Agilent 54750A only*

The Agilent 54750A mainframe has an additional menu selection, TDR/TDT cals, which allows previously stored normalization and reference plane calibration factors to be loaded for the Agilent 54653A, 54754 TDR plug-in modules. These calibration factors depend on the following TDR plug-in module conditions:

- The TDR plug-in module must be in the same mainframe slot it was when used to establish the stored normalization and reference plane calibration factors.
- The TDR plug-in module must be the same one used to establish the stored normalization and reference plane calibration factors.
- The time base values must be set to the same values used when the stored normalization and reference plane calibration factors were established.

Because the normalization and reference plane calibration factors depend on the timebase settings, the mainframe setup should be saved at the same time the TDR/TDT calibration factors are saved.

**NOTE**

Refer to "Type", later in this chapter, for more information on file types. Refer to "Setup Print Menu", later in this chapter, for more information on the TIFF, GIF, and PCX file formats.

---

## store

Store allows you to store waveforms, the color graded database, the pixel memory, front-panel setups, or a mask to the disk. Files are stored to the root directory only, and the appropriate extension is automatically appended to the file name. The file extensions are listed below.

- .WAV for internal waveforms.
- .WDB for databases.
- .TXT for text waveforms.
- .PIX for pixel memories.
- .SET for front-panel setups.
- .MSK for masks.

The .PCL, .TIF, .GIF, and .PCX file extensions are used by the Setup Print menu.

Use the knob, arrow keys, or keypad to scroll through the directory listing of the disk; or press the To File softkey to enter a file name. Pressing the To File softkey displays another softkey menu that allows you to enter a file name. When you execute the Store function, the instrument stores the information to whichever file name is listed under the To File softkey. If the file already exists on the disk, you are prompted to press the Continue key before the file on the disk is overwritten. You can either press the Continue key to overwrite the file, or you can press the To File softkey and enter a new file name. After the file is written to the disk, the file listing on the display is updated.

When you set the type as waveform, an additional softkey is available that allows you to select among the internal, text verbose, or text Y values formats. The text format makes it easy to transfer files to personal computer applications. The internal format maximizes the use of disk space, and allows for a higher waveform transfer rate to and from the disk.

Setup files are about 10 Kbytes in size and pixel files are about 15 Kbytes in size. However, the size of waveform files depends on the type of format, the setup of the instrument, and the waveform source. A blank high-density disk



has about 1.44 Mbytes of available space, so you could store about 140 setup files, or about 96 pixel files to a blank disk.

If the disk is full when the Store function is executed, the message “**The disk is full**” is displayed on the status line, which is near the upper-left corner of the display.

If there is a file on the disk with the same name and of the same file type, the instrument prompts you with the message “**File already exists, press Continue to overwrite the file.**” Press the Continue softkey to overwrite the file. Press the Cancel softkey to prevent the instrument from overwriting the file.

**Key Path**

**(Disk)** **Operation** **store**

**TDR/TDT cals**

*Agilent 54750A only*

The Agilent 54750A mainframe has an additional menu selection, TDR/TDT cals, which allows previously stored normalization and reference plane calibration factors to be loaded for the Agilent 54653A, 54754 TDR plug-in modules. Before the calibration factors can be stored an establish normalization and reference plane procedure must be performed. Refer to the *Agilent 54753A, 54754A TDR Plug-in Modules User's Guide* for instructions on performing this procedure.

Because the normalization and reference plane calibration factors depend on the timebase settings, the mainframe setup should be saved at the same time the TDR/TDT calibration factors are saved.

**NOTE**

Refer to “**Type**”, later in this chapter, for more information on file types. Refer to “Setup Print Menu”, later in this chapter, for more information on the TIFF, GIF, and PCX file formats.

**Disk Menu**

---

## delete

Delete allows you to delete a selected file from the disk. Simply use the knob, arrow keys, or keypad to scroll through the directory listing of the disk. Press the File Name softkey to enter a file name. Pressing the File Name softkey displays another softkey menu that allows you to enter a file name.

As a safeguard, the instrument prompts you to press the Continue key before deleting the selected file from the disk. This is to make sure you are not deleting a file from the disk by accident. If you select Continue, then the selected file is deleted from the disk. After the file is deleted, the directory listing on the display is updated.

**Key Path**

**(Disk)** Operation delete

---

## format

The Format function allows you to format 3-1/2 inch, high-density disks in the instrument. The formatted disks are MS-DOS® compatible, and can be used in other MS-DOS® compatible disk drives. You may notice there is a faster disk access time when you use disks in the instrument that were formatted by the instrument. This is because some computers and disk drives format disks with a different disk interleave factor than that used by the instrument. The interleave factor used when the instrument formats a disk maximizes the data transfer rate to and from the internal disk drive.

As a safeguard, the instrument prompts you to press Continue before formatting the disk. This is to make sure you are not accidentally formatting a disk. When you press Continue, the instrument will format the disk.

The instrument does not support the LIF format.

**Key Path**

**(Disk)** Operation format

---

## Type

Type determines the type of file that you store to a disk or load from a disk. The five file types are waveform, color graded database, pixel memory, setup, and mask. During a store operation, the file type also determines the file extension that is automatically appended to the file.

During a load operation, only those files that match the correct file type are listed on the display. The file type is determined from the file extension. The file extensions that the instrument uses to recognize file types are listed below.

- .WDB for databases
- .WAV for internal waveforms
- .TXT for text waveforms
- .PIX for pixel memories
- .SET for front-panel setups
- .MSK for masks
- .TDR for TDR/TDT calibrations *Agilent 54750A, firmware Rev. A.02.00 and higher, only.*

The .PCL, .TIF, .GIF, and .PCX file extensions are used by the Setup Print menu.

**Key Path**

**(Disk)** Operation load Enter Type

**Waveform**

The waveform file type is for storing waveforms to a disk or loading waveforms from a disk. The three file formats for storing waveforms to a disk are internal, text verbose, and text Y values. The format you select determines the file extension that is automatically appended to the file name during the store operation

- .WAV for internal waveforms.
- .TXT for text waveforms.

**Key Path**

**(Disk)** Operation load Enter Type Waveform Enter

## Disk Menu

### NOTE

Refer to "**Format**", later in this chapter, for more information on file formats.

### Color grade

The color grade file type is for storing the database to a disk or for loading a database file from a disk. A database file is stored in the internal format only, and database files have a .WDB file extension.

### Key Path

**(Disk)** Operation load Enter Type Color grade Enter

### pixel memory

A pixel memory file has a .PIX file extension. A pixel file is a copy of the pixel memory. It is a bitmap file, so it does not contain any vertical or horizontal scaling information. You can use pixel files as a template to compare other waveforms against, or you can make timing diagrams for signal analysis. When you load a pixel file into the instrument, it is loaded into the pixel memory by overwriting all data that was previously stored in the pixel memory.

### Key Path

**(Disk)** Operation load Enter Type pixel memory

### Setup

A setup file is a copy of the front-panel setups and it has a .SET file extension. Saving setups to a disk allows you to save more front-panel setups than the ten available in the instrument. Ten front-panel setups may not be adequate for a group of workers using the same instrument, or you may want to make sure that your front-panel setups are not accidentally modified by a coworker.

### Key Path

**(Disk)** Operation load Enter Type Setup

**mask**

The mask type is for storing a mask to a disk or for loading a mask file from a disk. A mask file is stored in an ASCII format only, and mask files have a .MSK file extension.

**Key Path**

**(Disk)** Operation load Enter Type mask

**Disk Menu**

---

## Format

The file Format softkey determines the format that is used to store waveforms to a disk. The three waveform file formats are internal, text verbose, and text Y values. The two mask file formats are mask only, and mask and setup.

When a text file is loaded into the instrument, it is placed into one of the four waveform memories by overwriting any data that was previously stored in that waveform memory.

**Key Path**

**[Disk]** Operation load Enter Type waveform Enter Format

**Internal**

The internal format is a binary file format, which if you try to read it in a word processing program, it will give you meaningless information. However, this is the preferred waveform-storage method because the files take up one-third as much disk space as text files. You can always convert them to text files at a later date. Internal format files have a .WAV file extension.

Waveform files stored using the internal format contain the vertical and horizontal scaling parameters of the original waveform. Therefore, you can go into the Waveform menu and turn on the display for the waveform memory that the file was loaded into. Then, you can perform measurements on the waveform, compare it to other waveforms, rescale it vertically and horizontally, or use it as a function operand.

**Key Path**

**[Disk]** Operation load Enter Type waveform Enter Format  
internal

**text verbose**

The text verbose format is an ASCII file format that uses alphanumeric characters to represent the waveform. You can load text files into a word processing program.

Text verbose waveforms have the file extension .TXT. You may notice that text files use about three times more disk space than files stored to a disk using the internal format. Table 11-1 shows an example of the text verbose format.

**Key Path**

```
(Disk) Operation load Enter Type waveform Enter Format
text verbose
```

**Header information**

When a text waveform is read back into the instrument, the header information can be in any order. On a versus waveform (refer to the Math menu), make sure the X data is listed before the Y data in the waveform text file. Because the instrument converts all characters to uppercase, the header information can be a mix of uppercase and lowercase characters. There must be at least one space between a header and its corresponding data. For example, there must be at least one space between "Type:" and "raw."

**Error Messages**

If you have modified the header information and a header field is omitted, the instrument sets that field to the default value. The default values are listed with the descriptions of each header field. If the header information is incorrect, you will get one of the following error messages.

**Waveform data is not valid**

An error was detected in the waveform data. This error occurs if one of the data points is not a valid floating point number.

**Header information is not valid**

An error was detected in the header information. This error occurs if one of the header fields or the header data is incorrect.

If the results are not what you expected after reading an ASCII waveform back into the instrument, the cause is that the instrument is interpreting your data differently than you expected. Try restoring the ASCII waveform from the waveform memory back to the disk. By comparing the restored data to what you had entered into the instrument, you may find your error.

**Disk Menu**

**Table 11-1.**  
**Partial listing of the Text Verbose Format for a Normal Waveform**

Type:	raw	6.866E-04
Points:	1350	1.211E-04
Count:	1	1.504E-04
XInc:	5.95556E-13	6.992E-04
XOrg:	3.2150200000E-08	7.890E-04
XRef:	0	1.274E-04
YData range:	1.77071E-03	1.399E-04
YData center:	4.37500E-04	7.140E-04
Coupling:	dc 50 Ohms	1.242E-04
XRange:	8.04000E-10	4.50E-05
XOffset:	3.2150200000E-08	7.776E-04
YRange:	1.60000E-03	1.158E-04
YOffset:	4.37500E-04	6.562E-04
Date:	10 OCT 1994	7.510E-04
Time:	17:47:09:09	8.778E-04
Frame:	83480A:sn ?	7.357E-04
Module:	83485A:sn ?	1.326E-04
Acq mode:	sequential	7.235E-04
Completion:	100	1.095E-04
X Units:	second	1.294E-04
Y Units:	Watt	1.598E-04
Max bandwidth:	12400000000	7.684E-04
Min bandwidth:	0	5.43E-05
Data:		9.80E-05
	6.646E-04	1.116E-04
	1.431E-04	7.285E-04
	1.169E-04	6.583E-04
	7.367E-04	8.382E-04
	1.441E-04	6.771E-04
	1.640E-04	1.085E-04
	6.898E-04	8.85E-05
	7.725E-04	7.490E-04
	6.961E-04	4.19E-05
	8.162E-04	7.480E-04
	5.01E-05	7.034E-04
	1.316E-04	6.260E-04
	7.024E-04	9.70E-05
	6.46E-05	7.755E-04
	6.667E-04	6.971E-04
	7.653E-04	6.46E-05
	1.148E-04	1.179E-04



<b>Text Verbose definitions</b>	Type	
	Type	Type describes how the waveform was acquired: raw, average, or versus. When this field is read back into the instrument, all the modes, except versus, are converted to raw. The default value is raw.
	Points	Points indicates the number of data points contained in the waveform record. The number of points is set by the Record Length softkey in the Acquisition menu. The default value is calculated.
	Count	Count represents the minimum number of hits at each time bucket in the waveform record when the waveform was created using an ensemble acquisition mode, like averaging. For example, when averaging, a count of four would mean every waveform data point in the waveform record has been averaged at least four times. Count is ignored when it is read back into the instrument. The default value is 1.
	XInc	X increment is the time duration between data points on the X-axis. X increment is equal to the YData range value for versus waveforms. The default value is calculated.
	XOrg	X origin is the x-value of the first data point in the data record. X origin is equal to the YData center value for versus waveforms. The default value is 22E-9.
	XRef	X reference is always set to zero when it is read back into the instrument. The default value is 0.
	YData range	Y data range is the full voltage range covered by the A/D converter. If this field is omitted, it is calculated when read back into the instrument. The default value is calculated.
	YData center	YData center is voltage level at the center of the YData range. If this field is omitted, it is calculated when read back into the instrument. The default value is 0, but value is calculated.
	Coupling	Coupling is ignored when it is read back into the instrument. The default value is dc 50 $\Omega$ .
	XRange	XRange is the time duration across 10 horizontal divisions of the display. The default value is 1.00000E-001.
	XOffset	XOffset is the time at the left edge of the display. The default value is 22E-9.

**Disk Menu**

YRange	YRange is the voltage across eight vertical divisions of the display. The default value is calculated.
YOffset	YOffset is the voltage at the center of the display. The default value is calculated.
Date	Date is the date when the waveform was acquired. The default value is 10 AUG 1992.
Time	Time is the time when the waveform was acquired. The default value is 01:00:00.
Frame	Frame is the model and serial number of the mainframe which acquired the waveform. The default value is 83450:314A00000 or 54750A:314A00000.
Module	Module is the model and serial number of the plug-in used in the mainframe to acquire the waveform. The default value is empty :314A00000.
Acq mode	Acquisition mode is the sampling mode used to acquire the waveform, which is always sequential. The default value is sequential.
Completion	Completion represents the percent of the time buckets in the waveform record that contain data. The number of time buckets is equal to the number of points in the waveform record. Completion is ignored when it is read back into the instrument. The default value is 100.
X Units	X units is the horizontal scaling units set in the Channel menu: unknown, Volt, Watt, second, constant, or Ampere. The default value is unknown.
Y Units	Y units is the vertical scaling units set in the Channel menu: unknown, Volt, Watt, second, constant, or Ampere. The default value is unknown.
Max bandwidth	Maximum bandwidth is an estimation of the maximum bandwidth limit of the source signal. The default value is 0.
Min bandwidth	Minimum bandwidth is an estimation of the minimum bandwidth limit of the source signal. The default value is 0.

**text Y values**

Text Y values files are identical to the text verbose files, except that the header information is deleted from the front of the file. Table 11-2 shows a partial example of the text Y values format. Text Y values files also have a .TXT file extension.

**Key Path**

**(Disk)** Operation load Enter Type waveform Enter Format  
text y values

**Disk Menu**

**Table 11-2. Partial Example of the Text Y Values Format**

5.841E-04	1.064E-04	8.54E-05
7.285E-04	7.203E-04	1.033E-04
1.347E-04	1.011E-04	3.88E-05
6.687E-04	1.305E-04	6.961E-04
6.77E-05	6.406E-04	7.530E-04
1.514E-04	7.003E-04	7.306E-04
8.413E-04	1.462E-04	1.095E-04
1.284E-04	1.148E-04	7.839E-04
6.479E-04	1.137E-04	5.33E-05
1.619E-04	1.263E-04	8.12E-05
1.274E-04	7.964E-04	8.23E-05
1.535E-04	1.085E-04	6.396E-04
1.085E-04	7.014E-04	8.12E-05
7.119E-04	6.573E-04	3.67E-05
7.520E-04	7.828E-04	7.684E-04
7.428E-04	7.182E-04	8.75E-05
1.525E-04	6.856E-04	7.357E-04
7.182E-04	1.399E-04	7.108E-04
1.724E-04	1.221E-04	1.033E-04
7.80E-05	7.571E-04	1.169E-04
6.971E-04	7.932E-04	6.793E-04
5.22E-05	9.48E-05	7.172E-04
7.398E-04	6.490E-04	7.295E-04
6.908E-04	7.398E-04	7.602E-04
7.014E-04	4.50E-05	8.319E-04
1.200E-04	9.80E-05	8.96E-05
8.100E-04	8.96E-05	8.246E-04
7.623E-04	7.510E-04	7.828E-04
6.98E-05	1.116E-04	6.604E-04
1.316E-04	1.106E-04	7.439E-04
6.982E-04	1.001E-04	8.75E-05
7.561E-04	7.932E-04	7.673E-04
7.922E-04	6.291E-04	
7.571E-04	7.337E-04	

---

## Mask Formats

You can select the Mask Only format or the Mask and Setup format. The Mask Only format loads the selected mask into the instrument. Loading the Mask and Setup format provides a convenient method for making sure the scaling of the mask is correct. You would use the Mask Only selection in cases where you do not want to change the present setup of the instrument. You must make sure the waveform time and amplitude scale is appropriate for the selected mask. An example of the Mask Only format is shown below.

**Key Path**

**[Disk]** **Operation** **store** **Enter** **Type** **mask** **Enter** **Format**

```
"STM16/0C48"
    /* polygon number */ 1
    /* number of vertices */ 4
0.400 , 0.250
0.600 , 0.250
0.600 , 0.750
0.400 , 0.750
    /* polygon number */ 2
    /* number of vertices */ 4
0.0 , MAX
0.0 , 1.250
1.000 , 1.250
1.000 , MAX
    /* polygon number */ 3
    /* number of vertices */ 4
0.0 , MIN
0.0 , -0.250
1.000 , -0.250
1.000 , MIN
```

---

## From File, To File, or File Name

The From File, To File, or File Name function (file field) is used to select a file name for a disk operation. Use the knob, arrow keys, or keypad to scroll through the directory listing. The file name in the file field matches the highlighted file name in the directory listing.

Another way to select a file is to select the File Field function. The File Name menu allows you to spell out the name of the file you want. The knob positions the cursor over a letter or number in the character list. Press **Enter** to enter that character into the file name field. You can also use the keypad to enter numbers into the filename. The arrow keys move the cursor forward and backward through the file name. The Backspace softkey backspaces over characters in the file name. The Delete softkey deletes characters from the file name. Press **Clr** on the keypad to erase the file name from the menu.

Do not add a file extension in this menu. The instrument automatically assigns a file extension depending on the type of file you selected. The file extensions are:

- .WAV for internal waveforms
- .WDB for databases
- .TXT for text waveforms
- .PIX for pixel memories
- .SET for front-panel setups
- .MSK for masks
- .TDR for TDR/TDT calibrations *Agilent 54750A, firmware Rev. A.02.00 and higher, only.*

The .PCL, .TIF, .GIF, and .PCX file extensions are used by the Setup Print menu.

---

## To memory

The To Memory function selects one of four waveform memories into which you can load a waveform. This function is available when the waveform type is selected. The instrument overwrites any data that was previously stored in the waveform memory.

### Key Path

**(Disk)** Operation load Type waveform To memory

---

## Display Menu

The Display menu controls most of the features that determine how the acquired data is displayed on the screen. You can select the graticule settings, and you can change the color of most of the items that are displayed on the screen. You can also annotate waveforms by using the Label menus to add text to the waveform viewing area.



---

## Persistence

The Persistence function determines how long a data point is kept on the display before the instrument erases it from the display.

You can have averaging and persistence on at the same time because when averaging is on, the averaging is done before the data is sent to the display. Averaging is controlled by the Acquisition menu.

### Key Path

**Display Persistence**

### variable

By selecting variable persistence, you can vary the persistence time from minimum to 40 s. When the persistence is set to minimum, all the displayed data points are kept on the display for one acquisition sweep. With the next acquisition sweep, all the previous data points are erased from the display, and new data points are written to the display. As you increase the persistence time, the previous data points are kept on the display depending on the persistence time you have selected. Therefore, the longer the persistence time, the longer each data point is left on the display before it is erased from the display. You can change the persistence time with the knob, arrow keys, or keypad.

The variable persistence mode has a feature called gray scaling. On older digitizing oscilloscopes, pixels were either turned on to full brightness or turned off. This gave you no feeling for how frequently events happened. In contrast, the relative brightness of a trace on analog analyzers told you the frequency of occurrence of events, but you usually used a viewing hood to see the extremely dim trace.

With gray scaling, the brightness of the pixel fades through up to eight levels of intensity, and the brightness of a pixel only depends on how often it is illuminated by acquired data points.

Gray scaling lets you see how frequently an event is happening. The most frequently occurring events tend to be brighter than less frequently occurring events. Gray scaling is more visible with a low persistence time, about 100 ms to 800 ms, and with dynamic signals. You can use gray scaling on PRBS signals (pseudo random bit sequence) or frequency modulated signals.

## Display Menu

A minimum persistence setting is used when the input signal is changing and you need immediate feedback. For example, if you are rapidly probing from point to point, or you are setting the amplitude or frequency of a signal source, you may find that more persistence is useful for observing long-term changes in a signal or observing signals with low repetition rates.

Because all of the data points acquired from a specific trigger event are displayed at the same intensity, the gray scaling feature provides the following benefits:

- Various points on the display can be associated to determine which points make up individual waveforms.
- The relative ages of waveforms can be determined.
- The direction in which a waveform is changing can be determined.
- The value of a waveform inside a waveform envelope can be determined.

### Key Path

**Display Persistence variable**

### infinite

You can use infinite persistence for worst-case characterization of signal noise, jitter, drift, and timing. When you select infinite persistence, all the data points are kept on the display until:

- **Clear display** is pressed
- **Autoscale** is pressed
- the vertical or horizontal settings are changed
- the trigger settings are changed
- the instrument is turned off

### Key Path

**Display Persistence infinite**

---

## Color grade...

The Color Grade function uses the same database as mask testing and histograms. The database is the size of the graticule area, which is 256 pixels high by 451 pixels wide. Behind each pixel is a 16-bit counter. Each time a pixel is hit by data, the counter for that pixel is incremented. The maximum count for each counter is 65,535.

The Color Grade function uses seven colors to show the number of hits per pixel over the graticule area. Each color represents a range of counts, and the range depends on the total number of hits. As the total count increases, the range of hits represented by each color also increases.

Color Grade is automatically implemented when performing automatic eye measurements. In this case, the displayed data corresponds directly to the database used to perform the eye measurements.

### Key Path

**(Display)** Color grade... on or off

---

## draw waveform

The Draw Waveform function determines how the data is displayed. There are three choices for drawing waveforms:

- fast
- connected dots
- high resolution

### Key Path

**(Display)** draw waveform

## Display Menu

### fast

Fast plots the data points on the display as fast as possible, which gives this mode the fastest throughput. If acquisition speed is what you need, use the fast mode.

When the waveform record length is less than 1000 points, the throughput of the instrument is fast enough that you can use the other display modes without noticing much decrease in throughput.

### Key Path

**Display** draw waveform fast

### connected dots

The Connected Dots function draws a straight line through the data points on the display. On waveforms where there are only a few dots representing the acquired data points, such as when the record length is small, you may find it easier to have a sense of what the waveform looks like. Figure 11-2 shows a waveform with only dots, and Figure 11-3 shows a waveform using connected dots.

Connected dots works on channels, functions, masks and waveform memories.

### Key Path

**Display** draw waveform connected dots

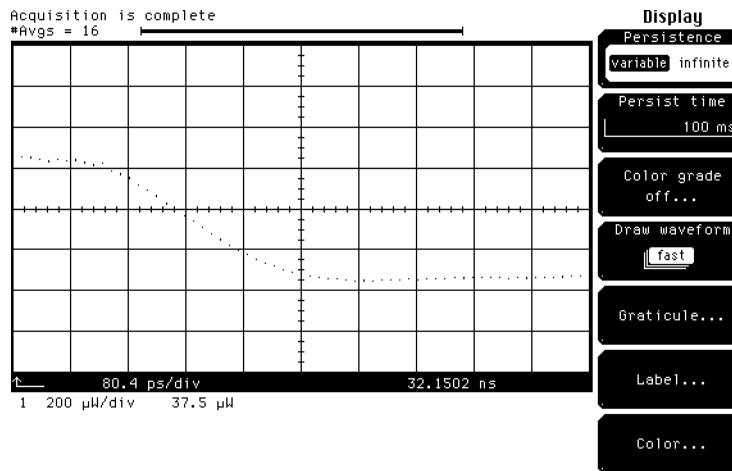
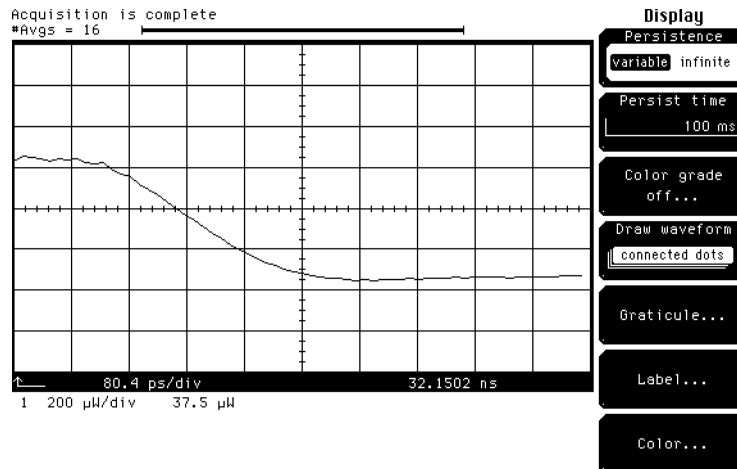

Figure 11-2. Dots only.



**Figure 11-3. Connected dots.**

## Display Menu

**high resolution** The high resolution function uses the full resolution of the waveform data to give the best possible representation of the waveform on the display. The high-resolution mode also makes the displayed waveforms look more analog. The waveform data in memory typically has a greater vertical resolution than the display. The high-resolution mode then uses a display technique that gives the display the appearance of more vertical resolution than the display actually has.

When the data point lies between adjacent pixels, the instrument lights up both pixels, but varies the brightness of each pixel. The brightness of each pixel is proportional to how close it is to the data point. Your eye is then drawn to a point between the two pixels to the data point. However, this increased vertical resolution does take microprocessor time, which slows down the display update rate of the instrument.

The high-resolution mode is not available when the mask test is running. The display update rate would be reduced without improving the appearance of the waveform on the display.

### Key Path

**Display** draw waveform high resolution

---

## Graticule

The Graticule menu is shown in Figure 11-4.

### Key Path

(Display) Graticule

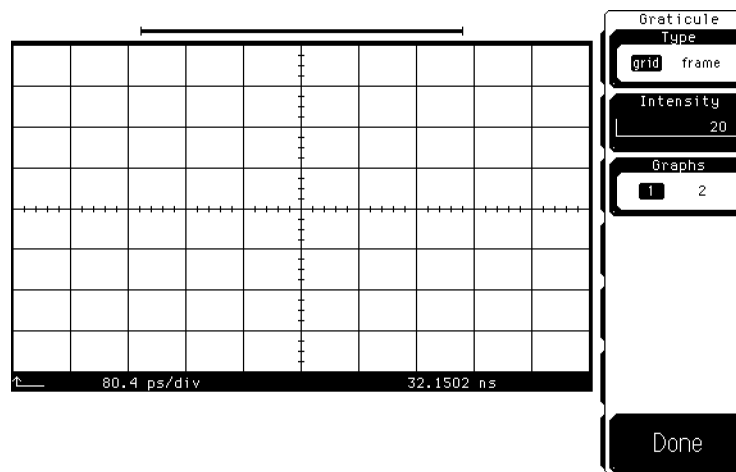

**Figure 11-4. Screen in grid mode using one graph.**

### Type

Type allows you to select either the grid or frame screen modes.

### Key Path

(Display) Graticule Type

### grid

Grid overlays a graticule on the waveform-display area that has ten major horizontal divisions and eight major vertical divisions. There are also tick marks on the axis to indicate minor divisions. Vertically, one minor division is one-quarter of a major division; and horizontally, one minor division is one-fifth of a major division. Figure 11-4 shows the screen in the grid mode.

### Key Path

(Display) Graticule Type grid

## Display Menu

### frame

Frame displays a border around the waveform-display area with ten major horizontal and eight vertical major divisions marked on the border. Figure 11-5 shows the screen in the frame mode.

Use the frame mode when printing to a monochrome printer, so that the graticule lines do not obscure the waveform data.

### Key Path

**Display** Graticule Type frame

### Intensity

Intensity controls the brightness of the horizontal and vertical graticule markings. You can vary the brightness from 0 (off) to 100 (very bright). Use the knob, arrow keys, or keypad to set the intensity level of the graticule. You can also change the color of the graticule in the Color menu.

### Key Path

**Display** Graticule Intensity

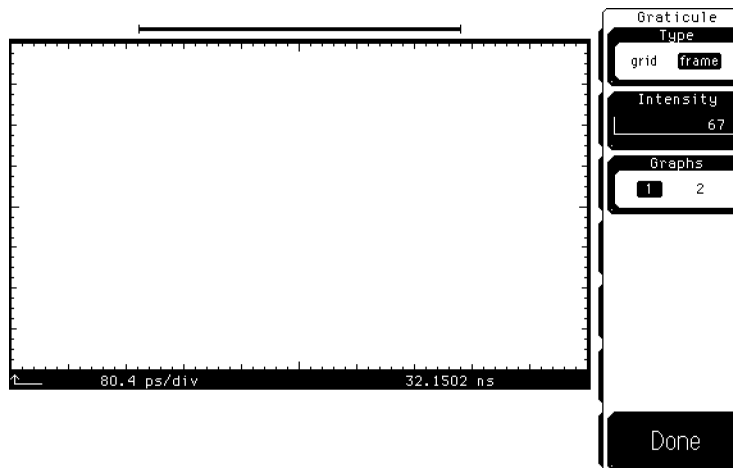

Figure 11-5. Screen in frame mode using one graph.



**Graphs**

With one graph, all displayed waveforms are in a single waveform viewing area. With two graphs, the waveform viewing area is divided in half. You can use the Waveform and Location functions to position any displayed waveforms in either of the two graphs. Figure 11-6 shows the screen divided into two graphs. The upper graph is channel 1 while the lower graph is waveform memory 1.

**Key Path**

**Display** Graticule **Graphs**

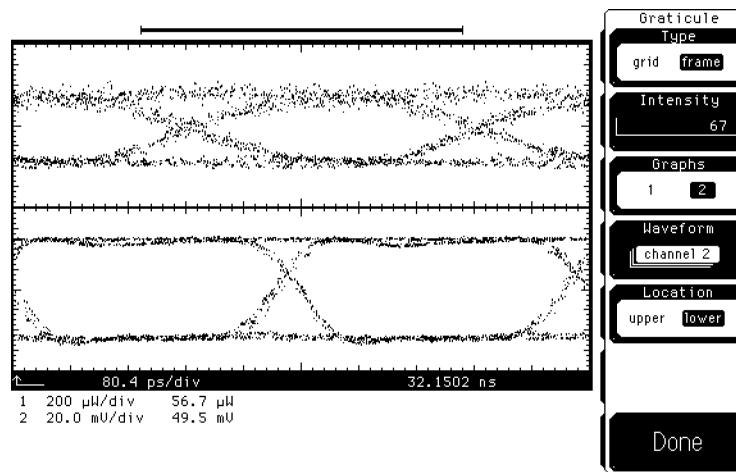

**Figure 11-6. Screen in frame mode using two graphs.**

**Waveform**

Waveform lets you select from channels, functions, or memories. Whatever is selected with the Waveform function is placed into the graph chosen by the Location function.

**Key Path**

**Display** Graticule **Graphs** 2 **Waveform**

**Location**

Location lets you select either the upper or lower graph. When you select upper or lower, whatever you selected with the Waveform softkey is displayed in the graph.

**Key Path**

**Display** Graticule **Graphs** 2 **Location**

## Display Menu

---

### Label

The Label function allows you to annotate waveforms with text. You can place up to 16 labels on the display, and each label can contain up to 64 characters. You can then print the display with the labels to a printer.

Remember, labels are not a part of the waveform. If you save the waveform to a waveform memory or to a disk, the screen labels are not saved with the waveform. However, labels are saved when you save front-panel setups with the Setup menu to a setup memory or to a disk.

For positioning the first character of the label, the waveform viewing area is divided into 19 vertical rows (0-18) and 64 horizontal columns (0-63). Label position 0,0 is the upper left hand corner and position 18,63 is the lower right hand corner.

#### Key Path

**Display** Label

#### Display

The Display function allows you to turn the labels off and on.

#### Key Path

**Display** Label **Display**

#### Define New Label

The Define New Label function allows you to add a new label to the waveform viewing area. When you press the Define New Label softkey, a second-level softkey menu comes up on the display. This second-level menu allows you to position the label and enter the text for the new label.

#### Key Path

**Display** Label **Define new label**

**Row**

The Row function allows you to select one of the 19 vertical rows for the placement of the label.

**Key Path**

**Display** Label Define new label Row

**Column**

The Column function allows you to select one of the 64 horizontal columns where the label is placed.

**Key Path**

**Display** Label Define new label Column

## Display Menu

### Label Text

The Label Text function brings up a third-level menu. This menu allows you to create a label, up to 64 characters long, with the letters and numbers from the character list shown at the left.

Spaces are allowed in a label. The space selection is located in the character list between the { } symbols.

- To move the cursor through the character list, use the knob.
- To select a character from the character list, use the **Enter** key on the keypad.
- To enter numbers into the file name, use the keypad or select numbers from the character list.
- To move the cursor through the file name, use the arrow keys.
- To erase the entire file name, press **Clr**.
- To move the cursor one character to the left in the file name and to also delete that character, use the Backspace softkey.
- To delete a character from the file name, use the arrow key to position the cursor over that character, then press Delete.

If labels overlap on the display, only the last label defined is displayed. The previous label is not erased, it is hidden by the last label defined. Either use the Modify Label function to reposition one of the labels, or use the Delete Label function to erase one of the labels from the display.

After you position the label, enter the text for the label, and turn the display on, the label does not appear on the screen until you press **Done** and exit back to the first-level Label menu.

### Key Path

**Display** Label Define new label Label text

### Modify Label

The Modify Label function allows you to either reposition or change the text of an already defined label.

### Key Path

**Display** Label Modify label

**Select  
Next Label**

The Select Next Label function allows you to select which label you want to modify. When you enter the menu, the first label you defined is highlighted. Each subsequent press of the softkey rotates through the remaining defined labels until you end up on the first label again.

You must select a label (highlighted) before you can change its position or modify its text.

**Key Path**

**Display** Label Modify label Select next label

**Row**

The Row function allows you to select one of the 19 vertical rows where you want to relocate the label.

**Key Path**

**Display** Label Modify label Row

**Column**

The Column softkey allows you to select one of the 64 horizontal columns where you want the label to relocate the label.

**Key Path**

**Display** Label Modify label Column

**Label text**

The description of the Label Text softkey is the same as the description under "Define new label", except that this softkey is used to modify the text of an existing label.

**Key Path**

**Display** Label Modify label Label text

**Delete...**

The Delete softkey allows you to delete a label from the display.

**Key Path**

**Display** Label Delete...

## Display Menu

Select  
next label

The Select Next Label function allows you to select the label you want to delete. When you enter the menu, the first label you defined is highlighted. Each subsequent press of the softkey rotates through the remaining defined labels until you end up on the first label again.

### Key Path

(Display) Label Delete... Select next label

Delete

The Delete softkey erases the selected label from the display. You must select a label (highlight) before you can delete it.

### Key Path

(Display) Label Delete... Delete

---

## Color

The Color menu allows you to modify the color of most items that are displayed on the screen.

### Key Path

(Display) Color

Color

The Color softkey allows you to choose from the list items. You can use either the knob or arrow keys to scroll through the list. As you scroll through the list, the name of each item and its current color is displayed next to the top softkey. Then, you vary the hue, saturation, and luminosity to modify the color of a selected item.

### Key Path

(Display) Color Color

You can change the color of the following items. They are listed in the order in which they appear in the Color menu.

Plug-in 1	The color of waveforms from the Channel1 installed in slot 1/2, and also the color of function 1 when it is turned on.
Plug-in 2	The color of waveforms from the Channel2 installed in slot 1/2, and also the color of function 2 when it is turned on.
Plug-in 3	The color of waveforms from the Channel3 installed in slot 3/4, and the color of the FFT waveform when it is turned on.
Plug-in 4	The color of waveforms from the Channel4 installed in slot 3/4.
Saved waveforms	The color of saved waveform memories and the pixel memory when they are displayed on the screen.
Trace overlap	The resultant color when two or more traces of a different color overlap.
Window marker	The color of the time base window marker.
Marker	The color of the waveform markers.
Graticule	Color of the graticule grid lines and tick marks.
Trace background	The color the waveform viewing area (graticule background).
Error	The color of error messages.
Advisory	The color of advisory messages and prompts. Examples of advisory messages are “Storing” and “Setup saved”.
Status	The color of status messages. Examples of status messages are “Acquisition stopped” and “Acquisition complete.”
Knob control	The color of the active entry field on the softkeys where you are entering values with the knob, arrow keys, or keypad; or you are selecting from a list of choices.
Menu foreground	The color of the softkey’s foreground and scale readouts in the graticule border.
Menu background	The color of the softkey’s background and scale readout background in the graticule border.
Menu outline	The color of the screen’s background.

## Display Menu

Menu highlight	The color of the outline around the softkeys that have an entry field.
Menu shadow	The color of the outline around the softkeys that have an entry field, which also gives the softkey a 3-dimensional effect.
Memory bar background	The color of the entire memory bar frame that represents the entire waveform record.
Memory bar foreground	The color of the memory bar part that represents what portion of the waveform record is currently displayed on the screen.
Display labels	The foreground color of the screen labels can be added to the waveform viewing area by using the Label softkey in the Display menu.
Color graded display	If the color graded display is turned on, you may also change the colors used for the color graded display. These colors are labeled “Db level 1” (least hits), “Db level 2”, . . . “Db level 7” (most hits). The color graded display must be on to change these colors.

### Hue

Hue is the gradation of color. You can use the knob, arrow keys, or keypad to vary the hue from 0 to 100. Red is at both 0 and 100, green is at 33, and blue is at 67.

### Key Path

**Display** **Color** **Hue**

### Saturation

Saturation is the percentage of color that is mixed with white. You can use the knob, arrow keys, or keypad to vary the percentage from 0 to 100. The 0 setting is white, regardless of the hue selection, and the 100 setting is the pure color as determined by the hue selection.

### Key Path

**Display** **Color** **Saturation**



**Luminosity**

Luminosity is the relative brightness of the color. You can use the knob, arrow keys, or keypad to vary the percentage from 0 to 100. The 0 setting is black, and the 100 setting is maximum brightness.

**Key Path**

**Display** **Color** **Luminosity**

**Default Colors**

The Default Colors softkey sets the instrument to the default colors. The default display colors were selected to:

- Improve the appearance of the display.
- Help you discern which waveform is on which channel by making each channel a separate easy-to-identify color.
- Bring error messages to your attention by displaying them in red.

However, you may prefer to change the color scheme to fit your personal tastes. Your color choices are saved with the front-panel settings when you save the settings to a setup memory or to a disk.

**Key Path**

**Display** **Color** **Default colors**

---

## Limit Test Menu

Limit test allows you to automatically compare measurement results with pass or fail limits, without having to use an external controller. Limit test independently tracks up to four measurements, and you can determine the fail action the instrument takes.

To select the Limit Test menu, press **Limit test**.

Figure 11-7 is a functional view of the limit test. Notice the test summary, screen dumps, and waveforms can each be sent to different destinations.

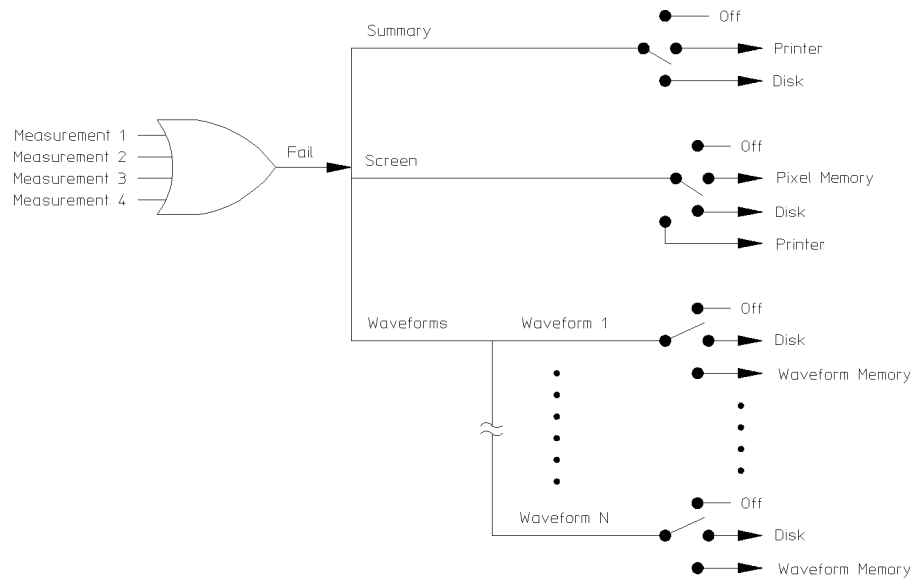

54720m12

**Figure 11-7. A functional view of the limit test.**

## Limit Test Menu

---

### Test

The Test softkey starts the limit test. Off keeps the limit test from running which allows you to set up test parameters before starting the limit test. On starts the limit test running. When the limit test is on, the total number of failed waveforms, the total number of waveforms measured, and the test status are displayed next to the measurement results.

While the test is running, you can toggle the Test softkey to off, which stops the tests and resets the total number of failures found to zero. Restarting the test from this point restarts the test from the beginning.

After the test has reached completion, the instrument stops the test and stops acquiring data. If you set the Test softkey to off after completion of the test, the test results are removed from the screen.

#### Key Path

**Limit test** Test

---

### Measurement

The limit test runs on all active measurements. There can be up to four active measurements. The Measurement softkey allows you to select each of the measurements and configure the Fail When, Upper Limit, and Lower Limit softkeys for that measurement. This allows you to individualize the test for each measurement that the instrument is running. The Run Until and Fail Action softkeys are global for all of the limit test measurements.

If automatic measurements are not running, the Measurement softkey displays None as the only choice. If None is displayed, select one or more measurements from the keypad for the instrument to run. Then, set up the limit test on those measurements.

#### Key Path

**Limit test** Measurement

---

## Fail When

The Fail When softkey brings up a second level softkey menu on the display. The Fail When function allows you to select when the instrument decides that a test has failed, and what to do with invalid measurements.

The four choices are fail inside the limits, outside the limits, always fail, or never fail.

### Key Path

**Limit test** Fail when

**Fail Inside** Fail Inside causes the instrument to fail on a test when the measurement results are within the parameters set by the Lower Limit and Upper Limit softkeys.

**Fail Outside** Fail Outside causes the instrument to fail on a test when the measurement results is greater than the upper limit or is less than the lower limit.

**Fail Always** Fail Always causes the instrument to fail on a test every time the measurement is executed, and the parameters set by the Lower Limit and Upper Limit softkeys are ignored. Use the Fail Always mode when you want to log the action each time the measurement is executed.

Fail always allows you to monitor trends in measurements. For example, you may want to track a measurement during an environmental test while the instrument is running a measurement for a long time as the temperature or humidity is changed. Each time the measurement is executed, the results are logged as determined by the Fail Action softkey.

**Fail Never** Fail Never sets the instrument so a measurement never fails on a test. Use the fail never mode when you want to observe one measurement but determine a failure from a different measurement.

The fail never mode allows you to monitor a measurement without having to set up any fail criteria.

### Key Path

**Limit test** Fail when Fail inside or outside or always or never

## Limit Test Menu

### Measurement Not Found

The Meas Not Found softkey allows you to determine what action the limit test takes when the instrument cannot perform a measurement. For example, if the instrument cannot find an edge on a rise time measurement, what action should the limit test take?

If the instrument is stopped, you can cycle through the selections to see the limit test results in more detail.

### Fail

Fail is used in cases where the instrument cannot make a measurement. For example, when an edge is expected to be present but is not found. The fail mode is used for most applications.

The total number of waveforms is incremented, and the total number of failures is incremented.

### Pass

You might use the pass parameter when triggering on one event and measuring another event that may not occur on every trigger. For example, in a communications system, you may want to trigger on the clock and test the rise times of edges in the data stream. However, there may be no way to guarantee that a rising edge is present to measure in the data stream at every clock edge. By using the pass parameter, the limit test will not log a failure if an edge is not found in the data stream.

If the measurement cannot be made, then the total number of waveforms measured is incremented, but the total number of failures is not incremented.

### Ignore

Ignore is similar to Pass, except that the totals for the number of waveforms and failures are not incremented. Therefore, the total indicates the number of tests when the measurement was available.

### Key Path

**Limit test** Fail when Meas not found fail or pass or ignore

---

## Upper Limit

The Upper Limit softkey sets the upper failure threshold. The units depend on which measurement is selected with the Measurement softkey.

**Key Path**

(Limit test) Upper limit

---

## Lower Limit

The Lower Limit softkey sets the lower failure threshold. The units depend on which measurement is selected with the Measurement softkey.

**Key Path**

(Limit test) Lower limit

## Limit Test Menu

---

### Run Until

The Run Until softkey brings up a second level softkey menu on the display. The Run Until menu allows you to specify when the instrument should stop running the limit test. The Run Until selections are global for all measurements.

#### Key Path

**Limit test** **Run until**

#### Mode

Mode allows you to determine when the limit test should stop. The three choices are run the test forever, run until a set number of failures occurs, or run until a set number of waveforms occurs.

#### Forever

Forever runs the limit test until you turn the test off.

Use the forever mode when you want a measurement to run continually and to not stop after a fixed number of failures. For example, you may want the limit test to run overnight and not be limited by a number of failures.

#### Failures

Failures runs the limit test until a set number of failures occurs.

When failures is selected, another softkey is displayed that allows you to set the number of failures.

Use the failures mode when you want the limit test to reach completion after a set number of failures. The total number of failures is additive for all of the measurements. For example, if you select 10 failures, the total of 10 failures can come from several measurements. The 10 failures can be the sum of four rise time failures, four + width failures, and two Overshoot failures.



**Waveforms**

Waveforms runs the limit test until a set number of waveforms are acquired. When waveforms is selected, another softkey is displayed that allows you to set the number of waveforms from 1 to 1 billion.

Use the waveforms mode when you want the limit test to reach completion after a set number of waveforms are acquired. The test terminates with the measurement that first reaches the specified number of waveforms.

**Key Path**

**Limit test** Run Until Mode forever or failures or waveforms

---

## Fail Action

The Fail Action softkey brings up a second level softkey menu on the display. The Fail Action menu allows you to specify what the instrument does with the test data after each test fails, or after the limit test is complete.

### Key Path

**Limit test** Fail action

### Store Summary

The summary is a log of the limit test data from failed test results. There are two parts to the summary. The first part is a header that is a running total of the number of tests that have failed. For example, if you have selected 10 failures, after five failures the summary might have two rise time measurements failed high, one rise time measurement failed low, and two + width measurements failed high. After each additional failure, the header information is updated to include the most recent number of failures.

The second part is the log of the test results. After each failure, all of the measurement parameters at the time of the failure are logged to the summary. After the limit test is complete, the summary contains a log of all the measurement results at each failure. When a failure does not occur during a set of measurements, the header information is updated to show that the measurements passed, but measurement results are not logged to the summary file unless a failure occurred. When the screen or a waveform is logged to a disk, a line is added to the summary file that indicates the file name.

The Format softkey allows you to determine if the summary file is brief or if it contains statistics. Brief is a one line log of the failure. Statistics includes the measurement statistics plus the one line log. Either format also documents files saved as a result of the failure.

When the destination is the printer, both the header portion and the log portion of the summary are printed after each failure and at the end of the test.

There is usually one summary file for the limit test.

The following events reset all the limit test results, which starts a new summary file.

- Changing any of the thresholds in the Define Measure menu.
- Changing the time base window, scale, position, reference, or resolution (number of points).
- Changing the trigger definition.
- Changing the sampling mode between real time and equivalent time.
- Changing the filter bandwidth, if measuring filtered data.
- Clearing the display.

The following events reset individual limit test results. If one of the following events also happens to reset all of the individual limit test results, then a new summary file is also started.

- Selecting a measurement.
- Turning on the display of the signal under measurement.
- Changing the channel state, scale, or offset for the measurement on that channel.
- Redefining a waveform math function, if the measurement is calculated on that function.
- Storing to memory, for the measurements calculated on that memory.
- Change the upper or lower limits.
- Change the fail when mode.

The store summary choices are off, printer, or disk.

**Off**

Off means that the summary data is not printed or stored.

**Printer**

Printer sends the summary to the destination determined by the Print selections. The destination can be one of several printers. The printer selection gives you a hardcopy of the summary information.

Refer to Setup Print menu for a description of the selections.

## Limit Test Menu

### Disk

Disk stores the summary information to a disk. The Store Summary menu allows you to specify the first four characters of the file name. The last four characters are reserved for consecutively numbering any subsequent summary files stored to the disk. If you select SUMM as the first four characters of the file name, the file name of the summary file stored to the disk is SUMM0000.SUM. The file name of the second summary file stored to the disk is SUMM0001.SUM. Each subsequent time the instrument stores a summary file to the disk, it checks which files are already on the disk, then increments the last four digits of the file name by one. If you change disks, the file number starts over again at SUMM0000.SUM.

Theoretically you can have up to 9,999 summary files. However, there are two limits that keep you from obtaining that many files. The first limit is with MS-DOS itself. MS-DOS limits the root directory to 224 entries (an entry is either a file name or subdirectory). Because the instrument can only access files in the root directory, that limits the maximum number of files the instrument can store to a disk to 224.

The second limit is the potential size of a summary file. The size of the summary file depends on how many measurements are made and the setup of the Run Until softkey.

Usually you will not have 224 summary files. However, if you are also storing screen and waveform information to the disk, there is the potential to fill up the disk. If the instrument cannot store additional files to the disk, the header portion of the summary is still updated, but additional logs are not appended to the summary file.

Messages like:

**Channel 1 could NOT be saved to the disk**

are caused by the following conditions:

The disk is write protected.

An MS-DOS disk is not in the drive.

The disk is full.

The maximum number of 224 files are already stored on the disk.

**Key Path**

**Limit test** Store summary Destination off or printer or disk

## Limit Test Menu

### Store Screen

The Store Screen function determines what the instrument does to the data on the screen on a failure. The screen data is a pixel dump of the entire screen area. The choices are off, pixel memory, printer, disk. The screen image allows you to see what the display looked like at the time of the failure, but you cannot rescale it later like you can with waveform memories or functions. If the Help menu is displayed on the screen at the time of the failure, then the Help menu is the screen image that is stored.

**Off** Off means that the an image copy of the entire screen area is not stored, printed, or retained.

**Pixel memory** Pixel memory stores an image copy of the entire screen area to the pixel memory; the same pixel memory that is accessed by the Waveform menu. Additional failures are added to the composite data stored in the pixel memory. The only way to clear the pixel memory is from the Waveform menu.

The value of the pixel memory selection is that you can save the waveform area from multiple failures to the pixel memory and have a composite view of the failures.

Refer to “Waveform Menu” for additional information on the pixel memory.

**Printer** Printer sends the image copy of the waveform area to the destination determined by the Store Screen menu. The destination can be one of several printers. The printer selection gives you a hardcopy of what the screen looked like at the time of the failure.

**Disk** Disk stores an image copy of the waveform area to a disk. The description for “Disk” under “Disk Menu” applies except the file extension depends on the selected print format. For example, the ThinkJet selection has a .PCL extension and the TIFF selection has a .TIF extension.

### Key Path

**(Limit test)** Store screen Destination off or pixel memory or printer or disk

**Store Waveforms** Store waveforms sends a copy of a channel, function, or memory to the selected destination of off, memory, or disk. Waveform is not an image copy of the waveform area. A stored waveform contains the vertical and horizontal scaling factors which allows you to bring the waveform back into the instrument for measurement or rescaling.

Waveforms are stored on a source-by-source basis. For example, you can store channel 1 to a file and channel 2 to a memory.

**Off** Off means that the waveform data is not stored, printed, or retained.

**Memory** Memory stores a copy of what the Source softkey is set to, to one of the four waveform memories; the same waveform memories that are accessed by the Waveform menu.

Because a waveform memory can contain only one waveform at a time, a waveform memory is best used when you are looking for one failure. You can send either the waveform that failed or another waveform to the waveform memory.

**Disk** Disk stores a copy of the waveform to a disk. The description for "Disk" under "**Fail Action**" applies.

Refer to "Waveform Menu" for additional details on waveform memories.

**Key Path**

**Limit test** **Store wforms** **Destination** **off** or **memory** or **disk**

---

## Marker Menu

This section describes the Marker menu and its functions. There are several marker modes:

- off
- manual
- waveform
- measurement
- histogram
- TDR/TDT

The Marker menu allows you to turn on and position colored markers on the display. The default marker color is orange. However, it can be changed to a different color in the Display menu. You can use the markers to make custom measurements, to use as visual reference points on the display, or to show you where the last automatic measurement was made on the signal.



---

## off

Turns off all of the marker functions, and removes the markers and marker values from the display.

The statistics measurement results share the same area of the screen as the marker values. In cases where you turn on statistics, the measurement marker positions hide the statistics measurement results. To see the statistics results, set the markers to off.

### Key Path

(Marker) Mode off

---

## manual

There are two sets of manual markers placed in the graticule area of the display. The X1 and X2 markers are two vertical lines you can move side to side, and the Y1 and Y2 markers are two horizontal lines you can move up or down.

You can position the manual markers anywhere on the display, which allows you to make custom measurements. The manual markers track the time and voltage values as the timebase and vertical scale are changed, which allows you to make accurate delay measurements without having both markers on the display. The markers are not tied to the waveform data; they are just positions in voltage or time and may not be on the display. The position readout is based on the scale factors of the source waveform. Marker resolution is limited to the pixel resolution of the display.

### Key Path

(Marker) Mode manual

**Marker Menu**

**X1, Y1 Source** and **X2, Y2 Source** You can set the marker sources as channels, functions, or memories. For example, you could set X1, Y1 Source to a waveform memory, and X2, Y2 Source to a function. The scale used to position each marker on the display is based on the scale of the waveform source to which the marker is tied. You can select a marker source that is turned off, which will prevent the markers from displaying on the screen. If you cannot see a marker on the screen, check to see if the marker source is turned off. When you are placing markers on a waveform, make sure the source is set to that waveform.

**Key Path**      **Marker** **Mode** **manual** **Enter** **X1, Y1 Source**

**Marker** **Mode** **manual** **Enter** **X2, Y2 Source**

**X1 Position** and **X2 Position** The X1 Position function moves the X1 marker horizontally, and the X2 Position function moves the X2 marker horizontally. The position of each marker is displayed, in the same color as the markers, near the bottom of the display. Use the knob, arrow keys, or keypad to change the marker position.

You can make timing measurements using the X markers on the signal. The difference between the marker's positions is the timing measurement or  $\Delta X$ .

$$\Delta X = X2 - X1$$

If X1 is more positive than X2,  $\Delta X$  will be a negative number, which can result in negative time interval measurements. Also notice the  $1/\Delta X$  value. If you are measuring the period of a signal with the X markers, then  $1/\Delta X$  is the frequency of the signal.

You can also make a channel-to-channel skew measurement by placing the X1 Marker on one channel and the X2 Marker on another channel.

**Key Path**      **Marker** **Mode** **manual** **Enter** **X1 Position**

**Marker** **Mode** **Manual** **Enter** **X2 Position**

**Y1 Position and  
Y2 Position**

The Y1 Position function moves the Y1 marker vertically, and the Y2 Position function moves the Y2 marker vertically. The position of each marker is displayed, in the same color as the markers, near the bottom of the display. Use the knob, arrow keys, or keypad to change the marker position.

You can make voltage measurements on the signal with the Y markers. The difference between the markers is the voltage measurement.

$$\Delta Y = Y2 - Y1$$

If Y1 is more positive than Y2,  $\Delta Y$  will be a negative number.

**Key Path**

**(Marker)** Mode manual Y1 Position

**(Marker)** Mode manual Y2 Position

**waveform**

There are two waveform markers: + and X. The waveform markers track the waveform data in memory rather than on the displayed waveform. Because the waveform data in memory has a much greater resolution than the display, the measurements you make with the waveform markers are much more precise than measurements made with the manual markers.

The waveform markers track the timebase changes of the source signal. This allows you to make accurate delay measurements without having both markers on the display. Vertical amplitude is not available unless the waveform markers are on the display.

**Key Path**

**(Marker)** Mode waveform

## Marker Menu

### +Source and X Source

You can set the marker sources as channels, functions, histograms, or memories. For example, you can set the +Source function to a waveform memory and the X Source function to a channel. The scale used to position each marker on the display is based on the scale of the waveform source that the marker is tied to. You can select a marker source that is turned off, which prevents the markers from displaying on the screen. If you cannot see a marker on the screen, check to see if the marker source is turned off. Also, when you are placing markers on a waveform, make sure that the source is set to that waveform.

### Key Path

(Marker) Mode waveform Enter +Source

(Marker) Mode waveform Enter X Source

### +Position and X Position

The + marker is controlled by the +Position function and the X marker is controlled by the X Position function. Use the knob, arrow keys, or keypad to position the markers on the signal.

The marker position readouts are displayed near the bottom of the display. Each waveform marker has a Y position and an X position. Vertical measurements are made with the Y positions, and  $\Delta Y$  is the difference between the Y positions. Timing measurements are made with the X positions, and  $\Delta X$  is the difference between the X positions. Also, notice  $1/\Delta X$ . If you are using the markers to measure the period of a signal, then  $1/\Delta X$  is the frequency of that signal.

### Key Path

(Marker) Mode waveform Enter +Position

(Marker) Mode waveform Enter X Position

#### NOTE

Refer to "Making Accurate Time Interval Measurements," in Chapter 9, for more information on placing markers off the display.

---

## measurement

The Measurement markers show you where on the signal the last automatic measurement was made. If you make an automatic measurement and the result is already displayed on the screen, then the instrument automatically places the markers when you select them. The markers will stay on the display until either you select a different marker mode, or you press the **(Clr meas)** key on the keypad. The measurement markers are not displayed if you do not have an automatic measurement active. The markers follow the last measurement, and the last measurement is displayed in the same color as the markers.

### Key Path

**(Marker)** Mode measurement

### Readout

The Readout function determines whether or not the measurement marker positions are shown at the bottom of the display. In cases where you turn on statistics, the measurement marker positions hide the statistics measurement results. To see the statistics results, set the Readout function to Off.

### Key Path

**(Marker)** Mode measurement **Enter** Readout

**Marker Menu**

---

## histogram

Histogram displays the Histogram markers, which are visual aids to help you locate the histogram markers on the display. The histogram markers are only displayed in the Histogram menu or when histogram is selected in the Marker menu. You can only reposition the Histogram markers from the Histogram menu.

**Key Path**

**Marker** Mode histogram

---

## TDR/TDT

*This function is only available in an Agilent 54750A, or an Agilent 83480A with the Agilent 54755A option installed.*

There are two waveform markers: + and X. The waveform markers track the waveform data in memory rather than on the displayed waveform. Because the waveform data in memory has a much greater resolution than the display, the measurements you make with the waveform markers are much more precise than measurements made with the manual markers.

The waveform markers track the timebase changes of the source signal. This allows you to make accurate delay measurements without having both markers on the display. Vertical amplitude is not available unless the waveform markers are on the display.

**Key Path**

**Marker** Mode TDR/TDT

**Marker hints**

You can select a marker source that is not displayed, for example, a memory that is turned off. Because the source is not displayed, the marker is not displayed either. However, you can still adjust the position of that marker even though it is not displayed, and this would affect any marker measurements you are making. Therefore, make sure you pay attention to where the marker sources are set when you are making marker measurements.

You may find yourself in a situation when the markers are turned on, but they are positioned off the display. You may notice that it can take a long time to bring the markers back onto the display with the knob. If you set the marker position to the time base position value, this will snap the marker to the same location as the time base reference. The time base position value is displayed on the screen below the waveform viewing area and to the right of the time base reference arrow. The time base reference location is the left or center of the display. For example, if the time base reference is set to center and you set the marker position to the time base position value, the marker will snap to the center of the display. Once the marker is located on the display, you can reposition it with the knob, arrow keys, or keypad.

---

## Setup Menu

The Setup menu allows you to save and recall up to ten front-panel setups in nonvolatile memories. You can use the setup memories for rapidly recalling setups for production test environments, or when you are comparing waveforms by using more than one setup. You can also set the instrument to its default settings. These settings set the instrument to a known operating condition.



---

## Setup memory

Setup memory selects which of the ten nonvolatile memory locations you want to store the front-panel setup to, or recall the front-panel setup from. The setup memories are numbered 0 through 9.

Setup memories allow you to easily recall a previous setup for viewing a waveform for further waveform comparison or analysis. You can also use the setup memories to save a front-panel setup in case someone else changes the setup when they are using it.

In situations where you need more than ten front-panel setups, or in work groups where you want to make sure that someone does not accidentally overwrite your saved setups, you can save setups to a disk. Refer to the Disk menu, earlier in this chapter, for information on saving to a disk.

### Key Path

**Setup** Setup memory

---

## Save

Save stores the present front-panel setup to a selected setup memory. Any previous setup saved to that setup memory is overwritten. The message “**Setup saved**” is displayed at the top-left corner of the screen indicating the setup was saved.

### Key Path

**Setup** Save

## Setup Menu

---

### Recall

Recall sets up the front panel by recalling a front-panel setup from a selected setup memory. The message “**Setup recalled**” is displayed at the top-left corner of the screen indicating the setup was recalled.

If a setup is recalled and you changed plug-ins, the instrument matches the recalled channel settings as close as possible to capabilities of the new plug-in.

#### Key Path

**Setup** Recall

---

### Default setup

The Default Setup function returns the instrument to its default settings. The default settings place the instrument in a known operating condition. This known operating condition is used as a starting point in the service procedures. You may find it helpful to use this known operating condition as a starting point when setting up the instrument to view signals.

#### Key Path

**Setup** Default setup

**Table 11-3. Default Setups**

<b>Global</b>			
Run/Stop	Run		
<b>Time Base</b>			
Units	Time		
Scale	1 ns/div	Windowing	Disabled
Position	22 ns	Windowing scale	500 ps/div
Reference	Left	Window position	22 ns
<b>Trigger</b>			
Source	Trigger 2 [Trigger 4 if no plug-in in slot 2]		
Level	0 V		
Sweep	Triggered		
Hysteresis	Normal		
Attenuation units	Ratio		
Attenuation	1.0:1		
Slope	Positive		
Trigger BW	2.5 GHz		
<b>Acquisition</b>			
Record length	Automatic		
Averaging	Off		
# of averages	16		
<b>Display</b>			
Persistence	Variable	Intensity	20
Persistence time	Minimum	Graphs	1
Draw waveforms	Fast	Labels	Off
Graticule	Grid	Colors	Default
<b>Color grade</b>			
Color grade	Off	Refresh rate	1 s
<b>Marker</b>			
Mode	Measurement	X1, Y1 source	First available channel
Readout	Off	X1 position	22 ns
Waveform + source	First available channel	Y1 position	0 V
Waveform + position	22 ns	X2, Y2 source	First available channel
Waveform X source	First available channel	X2 position	22 ns
Waveform X position	22 ns	Y2 position	0 V

**Setup Menu**

**Table 11-3. Default Setups (continued)**

<b>Define measure</b>			
Thresholds-percent	10%, 50%, 90%	Delta time	
Thresholds-volts	0.0, 1.6, 5.0	Start edge	Rising, 1, middle
Top-base	Standard	Stop edge	Falling, 1, middle
Statistics	Off	Color grade sig	NRZ
Top-base volts	0.0, 5.0	Eye Window1	40%
Measurements	Off	Eye Window2	60%
<b>Waveform</b>			
Pixel memory	Off	Memory display	Off
Waveform source	First available channel or memory 1		
Memory type	Waveform		
<b>Math</b>			
Function	f1	Vertical scaling	Track source
Function state	Off	Horizontal scaling	Track source
Operator	Magnify		
Operand 1	First available channel or memory 1		
Operand 2	First available channel or memory 1		
<b>Channel</b>			
Display	On	Bandwidth	20 GHz
Scale	50 $\mu$ W/div or 10 mV/div	Units	Volts (or Watts)
Offset	0 V or 0 W	External offset	0.0
Attenuation units	Ratio	External gain	1.0
Attenuation	1.0:1		
Optical filter	Off		
Wavelength	1.310 $\mu$ m		
<b>Histogram</b>			
Mode	Off	Run until	Forever
Axis	Horizontal	Run until waveforms	1000 waveforms
Window source	First available channel	Run until samples	100,000 samples
X1 & X2 position	0	Scale  log	20 dB
Y1 & Y2 position	0	Offset  log	-80 dB
Scale type	Linear	Scale  linear	25%
Scale mode	Auto	Offset  linear	0%

**Table 11-3. Default Setups (continued)**

<b>Utility</b>			
CRT pattern	Off	Calibration level	0.0 V
Light output	Off	Samplers	Enabled
Color purity	Off		
<b>Limit test</b>			
Test	Off	Run until	Forever
Measurement	None	Run until failures	1 failure
Fail when	Outside	Run until waveforms	1,000,000 waveforms
Upper limit	10	Store summary	Off
Lower limit	−10	Store screen	Off
		Store waveforms	Off
<b>Mask test</b>			
Test	Off	Run until	Forever
Scale source	Channel 1	Failed waveforms	1 failure
X1 position	22 ns	Failed samples	1 sample
$\Delta X$	10 ns	Waveforms	1,000,000
1 level	400 nW or 0.0 V	Samples	1,000,000
0 level	−400 nW or −200 mV	Store waveforms	Off
		Store summary	Off
		Store screen	Off
Mask Margins	Off		
Standard	Optical/STMO Electrical/STS1 Eye		

---

## Setup Print Menu

The instrument can print a copy of the screen to any of several printers or to the disk. It can print to an HP™ ThinkJet, PaintJet, LaserJet, DeskJet, or Epson printer. It can also save the printer file, a TIFF file, color TIFF, GIF, or a PCX file to the disk.

When you press **Print**, the instrument sends a copy of the screen to the device selected in the Setup Print menu. If that device is not connected to the instrument, the screen displays the message:

**Print canceled: Printer is not responding.**

When you are printing to a printer, the time and date of the printout is also printed at the top of the printed data. The date and time are the same as the instrument's. If they are incorrect, you can change the date and time in the Utility/System Configuration menu. Also, you can press the front-panel **Cancel print** key to stop the printing process.

**Setup Print Menu**

When you press the Setup Print key, a screen similar to Figure 11-8 is displayed. The exact screen displayed depends on the selected print format. The default format is ThinkJet.

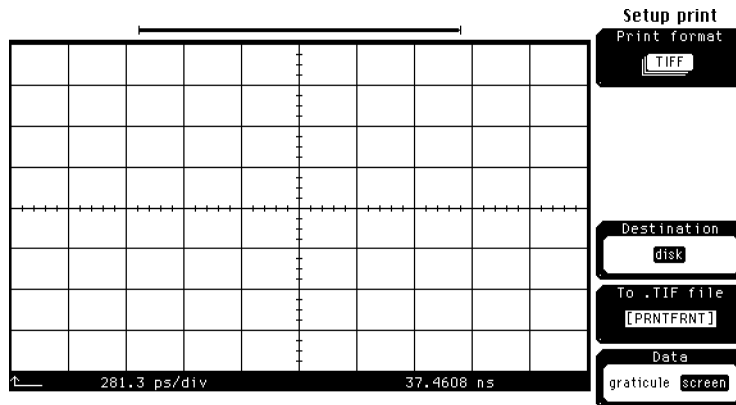

**Figure 11-8. Setup Print screen.**

The PaintJet, LaserJet, DeskJet, and Epson screens are similar to the ThinkJet screen, and the PCX, color TIFF, and GIF screens are similar to the TIFF screen.

**Setup Print Menu**

---

## Print format

The Print Format menu selects the format the instrument uses to print the screen to the selected destination. The printer formats available are ThinkJet, PaintJet, PaintJet B/W, LaserJet, DeskJet 500C, DeskJet 540C, DeskJet 550C, DeskJet 560C, DeskJet B/W, or Epson. When you print to a disk, the ThinkJet, PaintJet, DeskJet, or LaserJet file is saved to the disk in the Hewlett-Packard PCL printer language format, while the Epson printer file is saved to the disk in the Epson language format.

You can also print to a file on the disk in a black and white TIFF file, color TIFF, GIFF or 256 color PCX file. You can import the TIFF or PCX files to many desktop publishing programs or word-processing programs. The resolution is 576 x 368 pixels, so you need a super VGA display on your PC to see a complete screen image at 256 colors. Also, the TIFF and color TIFF files comply with the TIFF 5.0 file format.

Even though you select a printer as a print format, you can still select the disk as the destination instead of a printer. The resulting file is in the format for the selected printer. If a printer is not connected to the instrument, you can print the data to a disk. Then, you can take that disk to a computer or other device, and print from the disk to the printer.

To speed up the printing of data to printers, data is spooled to a buffer inside the instrument in 4 Kbyte blocks. After the first 4 Kbytes are in the buffer, the data is then sent to the printer. The buffer can hold up to four black and white files or one color file. The five color printers are the HP PaintJet, DeskJet 500C, DeskJet 540C, DeskJet 550C and DeskJet 560C.

**Key Path**

Setup print Print format



**Format** The Format softkey is displayed when PaintJet is the selected printer. Format allows you to select the type of media, paper length, and background for the PaintJet printout.

**Key Path** **Setup print** **Print format** **PaintJet** **Enter** **Format**

**Page Length** There are two paper size choices: English, which is 8-1/2 inches by 11 inches, or Metric, which is the A4 size, 210-mm by 297-mm.

**Key Path** **Setup print** **Print format** **PaintJet** **Enter** **Format** **Page length**

**Form Feed** Form feed allows you to turn on or off the form feed feature. When on, the instrument sends a form feed command to the printer after the printing of the data is complete.

**Key Path** **Setup print** **Print format** **PaintJet** **Enter** **Form feed**

**Media** Media allows you to select either paper or transparency as the printing material. The Media softkey is displayed when the DeskJet (color) and PaintJet printers are selected.

**Key Path** **Setup print** **Print format** **PaintJet** **Enter** **Format** **Media**

**Setup print** **Print format** **DeskJet** **Enter** **Format** **Media**

## Setup Print Menu

### Background

The Background softkey is displayed when the PaintJet is the selected printer. Background allows you to select either a normal or white background on the paper. Normal is the color of the trace background, and the default color of the trace background is black. You can change the color of the trace background in the Display menu.

### Key Path

Setup print Print format PaintJet Enter Format Background

---

## Destination

Destination allows you to select where to send the data. If the destination device is not connected to the instrument, the screen displays the message:

Print canceled: Printer is not responding.

### Key Path

Setup print Destination

### Centronics

Centronics prints to the parallel port on the rear panel of the instrument.

### Key Path

Setup print Destination Centronics

### HP-IB

HP-IB prints to the HP-IB connector on the rear panel of the instrument. When HP-IB is selected, an additional softkey is available that allows you to specify an HP-IB address for the printer.

*This function is not available for the HP DeskJet B/W printer.*

### Key Path

Setup print Destination HP-IB

---

**Disk**

Disk prints to the disk drive in the instrument. When disk is selected, an additional softkey is displayed that specifies the file name. If that file already exists on the disk, you are prompted to press the Continue key before the file on the disk is overwritten. You can either press the Continue key to overwrite the file, or you can press the To File softkey and enter a new file name.

To see a directory listing of the files on a disk, press:

**Disk**

**Select directory**

The instrument automatically checks for any files on the disk, and then displays a listing of all the files already on the disk.

If you need to create a file name, press the File Name softkey. You can create a file name with the letters and numbers from the character list. Use any of the characters from the character list in any order or combination. The file name cannot exceed eight characters.

- To move the cursor through the character list, use the knob.
- To select a character from the character list, use the enter key on the keypad.
- To enter numbers into the file name, use the keypad or select numbers from the character list.
- To move the cursor through the file name, use the arrow keys.
- To erase the entire file name, press **(Clr)**.
- To move the cursor one character to the left in the file name and to also delete that character, use the Backspace softkey.
- To delete a character from the file name, use the arrow key to position the cursor over that character, then press the Delete softkey.

You do not need to add a file extension to the file name because the instrument automatically assigns a file extension depending the type of file you selected. The file extensions are listed below:

.TIF for TIFF and color TIFF files  
.PCX for PCX files  
.PCL for PaintJet, ThinkJet, DeskJet, and LaserJet print files  
.EPN for Epson print files  
.GIF for GIF files

## Setup Print Menu

---

### Data

The Data function allows you to choose to print to a printer or disk:

- just the graticule area,
- the entire screen,
- only the setup factors.

#### Key Path

Setup print Print format

#### Graticule

Graticule prints only the waveform viewing area (graticule area) to the printer or to the disk. If you turn on Setup factors, the channel, time base, and trigger setups are also printed.

#### Screen

Screen prints the entire screen area to a printer or a disk. If you turn on Setup factors, the channel, time base, and trigger setups are also printed.

#### Factors

Factors print only the channel, time base, and trigger setups to the printer or to the disk.

---

## TIFF and GIF files on the Apple Macintosh Computer

To convert TIFF and GIF files for use on the Apple Macintosh™ computer:

1. Make sure the Apple Macintosh computer has a 1.44 Mbyte disk drive, also called “SuperDrive”.
2. Use the Apple Computer File Exchange utility, provided with the Apple Computer Macintosh System 7.0, to translate the MS-DOS® TIFF file format to a file on the Macintosh computer. Select “Default” translation in the “MS-DOS to MAC” menu.
3. Use a file editing utility, like ResEdit 2.1, available from Apple Computer, Inc., Macintosh ftp archive sites, or a local Macintosh User’s group, to open the TIFF file that you translated from MS-DOS® format to the Macintosh computer.

To use ResEdit, choose “Get File/Folder Info . . . ” from the “File” menu. Change the “Type:” field to “TIFF” for TIF files or change the “Type” field to “GIF” for GIF files. The type field must contain four characters, so make sure to use a space as the last character.

4. Save the changes, and Exit ResEdit.

The file is now ready for importing into a Macintosh computer application that can read TIFF files.

---

## Utility Menu

The Utility menu allows you access to these six additional softkey menus:  
HP-IB Setup, System Configuration, Calibrate, Self Test, Firmware Support,  
and Service.

---

## HP-IB Setup...

You may have several instruments connected by a common bus to a computer or controller. Each instrument on the bus has a separate identifying address, so the computer or controller can communicate with one instrument at a time. The HP-IB Setup menu lets you select an address from 0 to 31. The address number you select is the address that a computer or controller uses to communicate with the instrument. The default HP-IB address for analyzers is 7.

### Key Path

Utility HP-IB setup...

**Utility Menu**

---

## System config...

The System configuration function displays a screen similar to Figure 11-9.

The System Configuration menu gives you information about the mainframe and plug-ins. It allows you to set the date and time on the clock inside the mainframe. It also allows you to update the system firmware and to declassify the memory in the mainframe.

**Key Path**

**Utility** System config...

The screenshot shows the 'System config' menu with several options on the right and a main display area. The main display area is divided into three sections: Frame information, Board and Power Statistics, and Plug-ins.

**System config**

- Time: 16:55:47
- Date: 21 MAR 1995
- Declassify frame memory
- Update system firmware
- Exit

**Frame**

Model : 83480A, 54755A Option  
Serial Number : sn ?  
Calibration Memory : Unprotected  
Power On Test : Passed  
Firmware Revision : 0.00179 Mon Mar 20 17:06:01 1995  
Boot Revision : 1.1  
Application : none

Slot	Board	Power Statistics
6	CPU	Total Pon Time : 956.88hrs
5	Display	Length Last Poff : 20.65hrs
4		Time Since Pon : 1.70hrs
3		Power Cycles : 38
2	Acquisition	
1		

**Plug-ins**

Slot	Model	Serial #	Analog BW	Calibration Memory
1	83485A	3428A00055	20 GHz	Unprotected
2				
3	83483A	sn ?	20 GHz	Unprotected
4				

**Figure 11-9. The System Configuration display.**



<b>Frame</b>	The Frame display box contains the configuration of the mainframe.
Model	Indicates the instrument model number.
Serial Number	Indicates the instrument serial number.
Calibration Memory	Indicates if the cal memory is protected or unprotected.
Power On Test	Indicates if the power-on self-tests passed or failed. These power-on tests verify the six boards are in the mainframe. A “ <b>Failed</b> ” message indicates at least one board is loose or defective. The power-up routine is kept simple to enable the instrument to power up quickly. You can execute a more complete set of self-tests from the Self Test menu.
Firmware Revision	Indicates the revision number of the system firmware that is installed in the flash ROM memory.
Boot Revision	Indicates the boot ROM version in the mainframe. The boot ROM uncompresses files and loads new system firmware from the disk drive.
Slot	Indicates the slot where each board is installed.
<b>Power Statistics</b>	
Total Pon time	(Power on) The amount of time that the instrument has been turned on since it was manufactured.
Length Last Pof	(Power off) The amount of time that the instrument has been turned off since the last usage.
Time Since Pon	(Power on) The amount of time that the instrument has been turned on during this usage.
Power Cycles	The number of times that the instrument has been turned off and on since it was manufactured.

## Utility Menu

### Plug-in

The Plug-in display box contains the configuration of the plug-ins.

Slot	Indicates the slot where the plug-in is installed.
Model	Indicates the model number of the plug-in. If there is no plug-in in a slot, the model number is listed as empty. If the mainframe cannot recognize a plug-in, “~known” is displayed in place of a model number. If “~known” is displayed, try reinstalling the plug-in. If “~known” is still displayed, refer to the Service Guide for that plug-in because it indicates that the plug-in is defective or needs to be reprogrammed.
Serial number	Indicates the serial number of the plug-in that is stored in the nonvolatile memory inside of the plug-in.
Analog BW	Indicates the maximum analog bandwidth of the plug-in when used with the mainframe. Using probes and bandwidth limit filters can result in a lower system bandwidth for the associated channel.
Calibration Memory	Indicates the position of the memory calibration protect switch inside the plug-in. This switch is for the memory in the plug-in that contains the calibration factors from the last plug-in calibration. This switch is normally set to the unprotected position because the user must periodically perform the plug-in vertical calibration.

### Time and Date

The instrument has a 24-hour clock that it uses to stamp a time and date on waveforms when they are acquired. It also places a date and time stamp on files stored to the disk drive, on waveforms transferred over the HP-IB bus, and on waveforms that are printed. A printed waveform has both the time it was acquired and the time it was printed listed on the printout.

The instrument uses the same clock when it lists the date and time of the last calibration in the Cal status and Utility screens.

To change the time or date, simply press the Time softkey or the Date softkey. Then, change the time or date with the knob, arrow keys, or keypad.

### Key Path

**Utility** System config... Time or Date

**Declassify  
frame memory**

Declassifying the memory in the mainframe is a method to ensure sensitive information is not seen by individuals without the proper clearance. Declassifying the mainframe places zeros in the instrument's RAM memory. This clears all the setup memories, waveform memories, pixel memories, front-panel setups, channel memories, and function memories. Declassify the mainframe in situations when you are concerned about the security of the work you are performing.

For example, you would declassify the mainframe when you are going to leave the instrument unattended for a while or when someone is visiting your area that does not have the clearance to know about your work. When the instrument is not declassified, there is always the possibility that someone could analyze the front-panel setups or RAM memory of the instrument to determine the type of work you are performing. This process takes about 14 seconds to complete. Do not cycle power until the message is displayed. After the instrument declassifies the memory in the mainframe, the screen displays the message:

**Frame Memory is Declassified.**

This message stays on the screen until the instrument is no longer declassified.

## Utility Menu

The instrument remains declassified until a key is pressed, an HP-IB command is sent over the bus, a plug-in is changed, or the power is cycled. When the instrument declassifies the memory in the mainframe, the following actions are performed:

- acquisition is stopped.
- zeros are placed in RAM memory except for the following nonvolatile memory locations:
  - normal mainframe calibration.
  - normal plug-in calibration (located in the plug-in).
  - boot and system common variables.
  - clock memory.
  - the portion of the display RAM that holds the software for the graphics processor.
- all measurements are turned off.
- the default setup condition is stored in all of the setup memories.
- the instrument is placed in the default setup condition.

Refer to Chapter 10 for the default setup conditions.

### Key Path

**(Utility)** System config... Declassify frame memory

### Update System Firmware

The operating system for the instrument is located in the system ROM inside the instrument. The instrument does not need a disk in the disk drive in order to operate. The Update System Firmware softkey is for loading new system firmware into the instrument. Installing firmware is simply a matter of installing the system disk in the disk drive, then pressing the Update System Firmware softkey and following the directions on the display.

### Key Path

**(Utility)** System config... Update system firmware

---

## Calibrate...

### Calibrate Plug-in

The Calibrate Plug-in softkey is for performing service work on the instrument. Refer to the plug-in user's guide for more information about this key.

### Key Path

**Utility** Calibrate... Calibrate plug-in

### Calibrate Frame

The Calibrate Frame softkey is for performing service work on the instrument. Refer to the Service Guide supplied with the instrument for details about this key.

### Key Path

**Utility** Calibrate... Calibrate frame

The General Function Menus

## Utility Menu

### Cal Status

When the Cal Status softkey is set to on, a screen similar to Figure 11-10 is displayed.

### Key Path

**Utility** Calibrate... Cal status

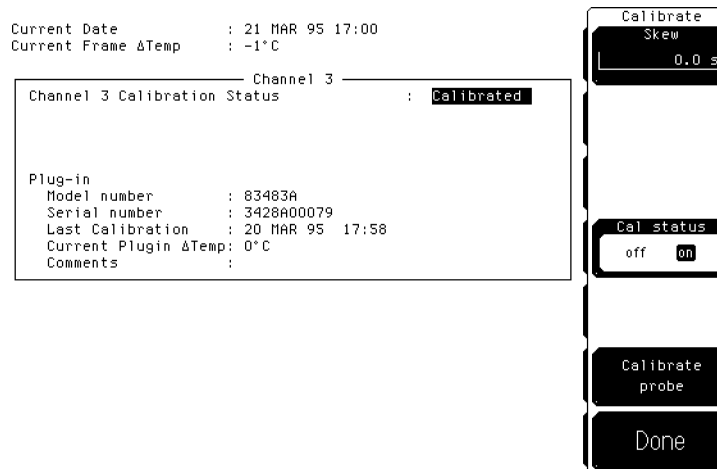

Figure 11-10. A typical Cal Status display.

Current Temperature	This is the temperature change inside the instrument between the last mainframe calibration and now. A positive number indicates how many degrees warmer the mainframe is now compared to the temperature of the mainframe at the last mainframe calibration. If the current temperature delta is more than $\pm 5^{\circ}\text{C}$ , you have to perform a mainframe calibration. Refer to the Service Guide supplied with the instrument for calibration details.
Last Calibration	This is the date and time of the last mainframe calibration.
Calibration Memory	This is the status of the Frame cal switch on the rear panel. This switch is normally set to the protected position; before performing a mainframe calibration, set the switch to the unprotected position. Make sure you return it to the protected position after completing the calibration.
Frame Calibration Status	Indicates the calibration status of the mainframe, which is either calibrated or uncalibrated. Below the Frame Calibration Status line is a display of each slot and whether the slot passed or failed the calibration. If any part of the calibration process fails, then the Frame Calibration Status line also displays failed.
Slot	Indicates the slot where each plug-in is installed.
Model	Indicates the model number of the plug-in. If a plug-in is not installed in a slot, the model number is listed as empty for that slot. If the mainframe cannot recognize a plug-in, " <b>-known</b> " is displayed in place of a model number. If " <b>-known</b> " is displayed, try reinstalling the plug-in. If " <b>-known</b> " is still displayed, refer to the Service Guide for that plug-in because it indicates that the plug-in is defective.
Memory	Indicates the position of the memory calibration protection switch inside the plug-in. This switch is for the memory in the plug-in that contains the calibration factors from the last plug-in calibration. This switch is normally set to the protected position; so before calibrating a plug-in, make sure that the memory protect switch in the plug-in is in the unprotected position. Make sure you return it to the protected position after completing the calibration.

## The General Function Menus

### Utility Menu

Date and Time	Indicates the date and time of the last normal plug-in calibration.
Accuracy	Calibrated or Uncalibrated, depending on what calibration was last performed on the plug-in.  Uncalibrated indicates the calibration factors in the plug-in are set to the default state. See the Service Guide that is supplied with the plug-in for calibration information.
$\Delta$ Temp	Indicates the temperature change from the temperature when the last calibration was performed.

**level** The Level function allows you to set the level of the dc output voltage for the front-panel Cal output (BNC connector).

**Key Path** (Utility) Calibrate... level

**Samplers** This function enables or disables samplers for service. (See Service Guide.)

**Key Path** (Utility) Calibrate... Samplers

**Output** Output lets you select the output signal for the front-panel CAL signal on the mainframe. The output is dc and can be adjusted from  $-2.5$  Vdc to  $+2.5$  Vdc into  $50\Omega$ . The CAL signal is used for mainframe calibration, plug-in calibration, probe calibration, skew calibration, and as a demonstration signal.

---

## Self-test...

The Self-test menu is for performing service work on the instrument. Refer to the Service Guide supplied with the instrument for details about this menu.

**Key Path** (Utility) Self test...



---

## Firmware support...

When you press the Firmware Support key, a screen similar to Figure 11-11 is displayed.

The Firmware support function lets you print a copy of the problem report form or the firmware request form. You may not have originally purchased the instrument or you may share the instrument with several coworkers. These forms are your way of communicating with the manufacturer of the instrument, Agilent Technologies. Because both forms reside in the memory of the instrument, you can print out a copy of either form whenever you need one.

### Key Path

**Utility** Firmware support

Problem Report  
If you have encountered a problem using this product, please complete a Problem Report Form. Mail or FAX it to Hewlett-Packard at this address:

Lightwave Product Support Engineer  
Hewlett-Packard Company  
1412 Fountaingrove Parkway  
Santa Rosa, CA 95403, USA  
Phone: (707) 577-5643  
FAX: (707) 577-5221

You may print this form on your local printer by first configuring the instrument for your printer using the Setup print menu (shift Print) and then pressing the appropriate key in this menu. Configuration information will automatically be appended as you create the form.

If a printer is not available, look for forms in the HP 83480 Digital Communications Analyzer User's Reference.

**Support**  
Print  
problem  
report

**Exit**

Figure 11-11. A typical Firmware support screen.

## The General Function Menus

### Print problem report

The problem report is used when a problem is encountered when using this instrument. Complete the problem report and mail or FAX it to Agilent Technologies.

You can print out a problem report by simply connecting a printer to the instrument, selecting printer in the Setup Print menu, then pressing the Print problem report softkey. If a printer is not available, make a copy of the form at the end of this chapter.

---

### Service...

The Service function is for performing service work on the instrument. Refer to the Service Guide supplied with the instrument for details on the features in this menu.

### Key Path

**Utility** Service...

**Problem Report Form**

Name \_\_\_\_\_ Job Title \_\_\_\_\_  
Company Name \_\_\_\_\_ Division \_\_\_\_\_  
Telephone Area/Country Code \_\_\_\_\_ Phone Number \_\_\_\_\_  
Street Address \_\_\_\_\_ Fax Number \_\_\_\_\_  
Mail Stop \_\_\_\_\_ Department \_\_\_\_\_  
City \_\_\_\_\_ Prov/State \_\_\_\_\_  
Postal/Zip Code \_\_\_\_\_ Country \_\_\_\_\_  
Date \_\_\_\_\_

Problem Report Classification  
\_\_\_\_\_ Hardware/Mechanical Problem \_\_\_\_\_ Documentation Problem  
\_\_\_\_\_ Software/Firmware Problem \_\_\_\_\_ Remote Programming Problem  
\_\_\_\_\_ Suggested Enhancement

Problem Description  
\_\_\_\_\_  
\_\_\_\_\_  
\_\_\_\_\_  
\_\_\_\_\_

**The General Function Menus**

**Problem Report Form (continued)**

System Description (Remote controller, Software, Printer, Cables)

---

---

---

---

Your current configuration is: \_\_\_\_\_ Software revision \_\_\_\_\_

Mainframe model number \_\_\_\_\_ Serial number \_\_\_\_\_

Plug-in 1 model number \_\_\_\_\_ Serial number \_\_\_\_\_

Plug-in 2 model number \_\_\_\_\_ Serial number \_\_\_\_\_

Plug-in 3 model number \_\_\_\_\_ Serial number \_\_\_\_\_

Plug-in 4 model number \_\_\_\_\_ Serial number \_\_\_\_\_

How would you prefer to be contacted? Mail \_\_\_\_\_ Fax \_\_\_\_\_ Phone \_\_\_\_\_

Who is your local Agilent sales representative? \_\_\_\_\_

Return this form to Agilent Technologies

Agilent Technologies  
Service Manager, MS 1US-F  
1412 Fountaingrove Parkway  
Santa Rosa, CA 95403-1799, USA  
Fax Number (707) 577-5221

---

## Waveform Menu

The Waveform menu allows you to save or recall a waveform to a waveform memory or to the pixel memory. When you recall a waveform from a waveform memory or the pixel memory, it is displayed in the default color blue. However, you can change the default color in the Display menu.

## Waveform Menu

---

### waveform

The Waveform function allows you to store waveforms to one of the four nonvolatile memories in the instrument.

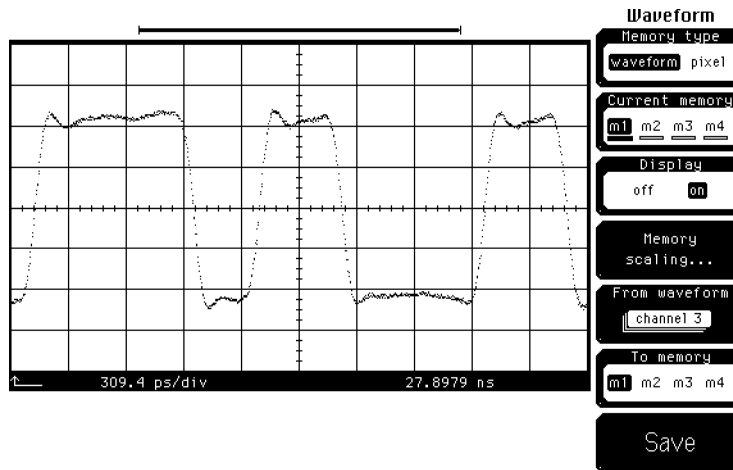

Figure 11-12. Storing a waveform.

#### Key Path

**Waveform** Memory type waveform

#### Current memory

The Current Memory softkey simply shows the currently selected memory.

When the display for a memory is turned on, the bar below the memory fills in and turns blue. (The default color is blue.) If the display memory is turned off, an open white box (default color) is displayed.

#### Key Path

**Waveform** Memory type waveform Current memory

**Display**

The Display function turns a memory location on and off. Memories are displayed in blue (default color). If a channel or function display is also on and its display is set to the channel default colors, any trace overlap is displayed in pink (default color).

**Key Path**

**Waveform** Memory type waveform Current memory Display

**Memory scaling**

The Memory Scaling softkey allows you to rescale a waveform vertically and horizontally to make waveform comparison or analysis easier. The Current Memory softkey selects which memory you want to rescale. You turn on a memory with the Display softkey, and when a memory is on, the Memory Scaling softkey is displayed.

Rescaling a waveform changes the vertical and horizontal parameters of the waveform. You use the knob, arrow keys, or keypad to change the values of the four scaling softkeys. Y Scale changes the vertical scaling of the waveform, and Y Offset moves the waveform vertically up and down. X Scale expands and contracts the waveform horizontally, while X Position moves the signal horizontally.

**Key Path**

**Waveform** Memory type waveform Current memory Display on  
Memory scaling

**From waveform**

The From Waveform softkey allows you to choose the source of the waveform you intend to save. You can choose between channels, functions, FFT, memories, or histogram as the waveform source. Pressing the From Waveform softkey brings up a selection box that allows you to change to a different waveform source.

**Key Path**

**Waveform** Memory type waveform From waveform

## Waveform Menu

### To Memory

The To Memory softkey selects which of the available memory locations the instrument saves the waveform to. Pressing the To Memory softkey toggles among the nonvolatile memory locations.

When a waveform is saved to a memory, it overwrites any data that was previously stored in that memory. All pulse measurements or functions using that memory location are recalculated. If the waveform display is on, then the display is also updated.

Waveform memories are nonvolatile so the data is not lost if you press Autoscale, turn off the power, or set the instrument to the default settings. A waveform memory contains a single waveform record, including the horizontal and vertical scaling parameters. Therefore, you can make parametric measurements on stored waveforms or use them as operands in a function. You can also recall the waveform for future comparison or analysis, print it, save it to a disk, or load it from a disk.

It takes less time to store and recall data to waveform memories than to store the same data to the disk drive. Therefore, you may find it more convenient to use the four waveform memories for storing data temporarily, and the disk drive for storing data permanently.

### Key Path

**Waveform** Memory type waveform To memory

### Save

The Save softkey copies the selected waveform to the selected memory. If you are saving a persistence trace to a waveform memory, only the last waveform record is saved to that memory. That is because waveform memories store only single-valued, time-ordered data, and persistence traces are multivalued sets of data. Use the pixel memory to store persistence traces.

### Key Path

**Waveform** Memory type waveform Save



---

## Pixel

There is one pixel memory, but you can save several waveforms to that pixel memory. Saving to the pixel memory is like taking a picture of the graticule area. It is a bitmap of the graticule area, and the horizontal and vertical parameters are not saved.

The pixel memory is volatile, so turning off the instrument clears the pixel memory. However, setting the instrument to the default instrument setups does not clear the pixel memory. Gray-scale persistence information is not saved to a pixel memory.

You can save several waveforms to the pixel memory, and each waveform can have different time base and channel scale factors.

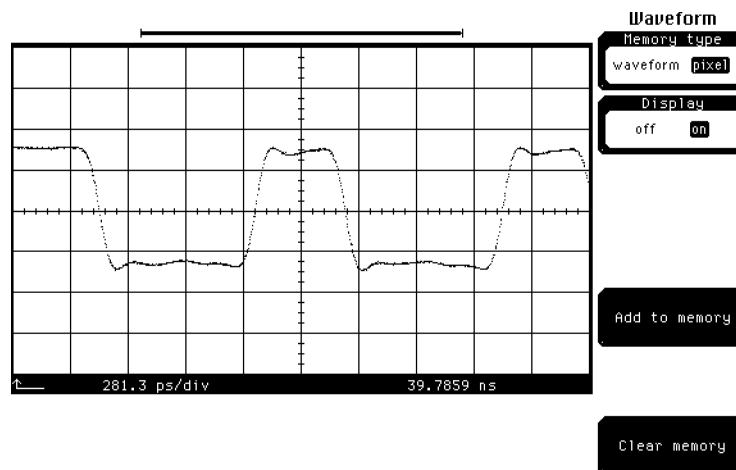

Figure 11-13. Saving to pixel memory.

Key Path

**Waveform** Memory type pixel

## Waveform Menu

### Display

Display turns on and off the pixel memory. When the pixel display and the channel display are both on, the instrument displays any trace overlap in a different color. The default color is pink; however, you can change the default color in the Display menu.

### Key Path

**Waveform** Memory type pixel Display

### Add to memory

Add to memory places additional snapshots of the graticule area in the pixel memory without overwriting any previously stored data. By using the channel offset to move signals vertically on the display, you can create a timing diagram by saving multiple screen snapshots to the pixel memory. Then, you can save the timing diagram to a disk or you can print it.

### Key Path

**Waveform** Memory type pixel Add to memory

### Clear memory

Clear memory erases any data stored in the pixel memory.

### Key Path

**Waveform** Memory type pixel Clear memory

**Messages**

---

# Messages

## Instrument Messages

### **What you'll find in this chapter**

This chapter contains an alphabetical list of messages you may see on the display of your instrument. Only messages needing explanation are contained in this chapter. Messages that are the result of an action you have taken, explain what the instrument is doing, or notify you the action you have requested has occurred are not listed here.

Each message listed here has an explanation and, if necessary, the action you should take to remedy the condition.

---

## Messages you may see on your instrument

### **A coupled control changed?**

The question mark is a string substitution point that contains the name of a control that changed, for example: A coupled control changed: Time base position. In this example, the message indicates the horizontal position was changed to account for the bit rate being increased.

### **A memory error was detected: Service is required**

This is likely a hardware failure, although it could be a firmware error. It is possible you will lose data if you do not get the system serviced.

### **A system firmware file was not found on the disk**

Either the file on the disk is corrupt or the disk may be the wrong one.

**Busy timeout occurred with plug-in ?: Try reinstalling plug-in**

The plug-in busy signal was present too long. The “?” indicates which plug-in had the timeout. Check the following:

Reinstall the plug-in.

Finger tighten the knurled screw on the front panel of the plug-in. If these actions do not solve the problem, there must be a hardware problem in the mainframe or plug-in. Call Agilent Technologies for service.

**Color graded display must be on**

The color graded display is required for this operation. Turn on color graded display by pressing:

**Display**

**Color grade On**

**Communication failure exists at slot ?: Service is required**

There is a problem with the interface between the mainframe and the plug-in. The “?” indicates which slot has the failure. This is a mainframe hardware problem if the slot is empty, otherwise there must be a hardware problem in the mainframe or plug-in. Call Agilent Technologies for service.

**Control setting is unchanged: Entry was not completed**

The Enter key was not pressed after typing in numbers, using the keypad, before changing menus. If the entry is still desired, it will have to be completely entered again.

**Function cannot be performed on the selected waveform**

The function is not defined for this waveform type, therefore it cannot be performed.

**ID error occurred in plug-in ?: Service is required**

The information that the mainframe downloaded from the plug-in's memory is inconsistent with the plug-in's hardware. The “?” indicates which plug-in has the ID error. This is a special case of memory error. Check the following:

**Waveform Menu**

Reinstall the plug-in.

Finger tighten the knurled screw on the front panel of the plug-in.

If these actions do not solve the problem, there must be a hardware problem in the mainframe or plug-in. Call Agilent Technologies for service.

**Incompatible setup**

It is possible that due to a system firmware change, a previously saved setup may become incompatible.

**Incompatible signal**

An attempt was made to load a signal format that is incompatible with the instrument from disk.

**Low battery voltage detected: Service is required**

Change the battery as soon as this message is displayed. Cal factors and data may be lost when the power is cycled, and the instrument may not function correctly. When Agilent Technologies service replaces the battery, a revised boot ROM may be installed.

**Mask test align failed**

The mask test align algorithm was not able to detect a signal compatible with the installed mask. This can occur when there are not enough points on an edge or when the required edges are not present. Adjust the timebase to place the required edges on the display.

**Measurement cannot be performed on the selected waveform**

The measurement is not defined for this waveform type, and cannot be made. For example, the rise time of an A versus B waveform is not defined.

**Memory error occurred in plug-in ? : Try reinstalling plug-in**

The checksum or contents of the plug-in's memory is incorrect. The "?" indicates which plug-in has the error. Check the following:

Reinstall the plug-in.

Finger tighten the knurled screw on the front panel of the plug-in.

If these actions do not solve the problem, there must be a hardware problem in the mainframe or plug-in. Call Agilent Technologies for service.

**Plug-in ? is not supported: System firmware upgrade is needed**

In the future, new plug-ins may require a certain revision of system firmware for proper operation. The “?” indicates which plug-in is not supported.

**Plug-in configuration has changed**

The physical configuration of the plug-ins is different from when the setup was saved to memory or disk. The system has tried to establish the same setup.

**Plug-in initialization will destroy factory calibration factors**

Optical calibrations for 1310 nm and 1550 nm are performed on the plug-in modules by Agilent Technologies prior to shipping the modules. If the plug-in module is reprogrammed, the factory calibration factors will be erased.

**Plug-in is not installed**

This requested plug-in or channel is not installed in the instrument.

**Setup defaulted**

This normally occurs when you ask for setup to be defaulted. At power on, the setups are defaulted if a memory error was detected or had occurred prior to power down. The setup is also defaulted when new system firmware is installed or when the memory is declassified in the Utility menu.

**System firmware error occurred**

This is a defect diagnostic that should be reported to Agilent Technologies service. Normally, the address where the error occurred is also displayed. Record the address to help in servicing the instrument. The instrument is still operable.

**System load failed: System firmware is unchanged**

## Messages

This can be caused by either a corrupt disk file or a hardware failure. Try another system disk file to narrow the problem to the file or the hardware. If it is a hardware failure, call Agilent Technologies for service.

**The 83480K option is not installed.**

**The 54755A option is not installed.**

This message appears when an attempt is made to execute a feature that requires an upgrade option and the option is not installed in the instrument.

**The selected point caused an intersection and is not valid**

When attempting to connect to the newly inserted mask data point, the line intersected a line connecting two previously joined points. This is illegal and the point is not accepted.

**Unable to measure dark level**

Check the extinction ratio dark cal signal level. The dark cal routine requires that the dark signal level be on screen. Change the vertical scale or offset to obtain the desired waveform on screen.

**Waveform data is not valid**

An attempt was made to query invalid data. Verify the data on the disk is valid and acquire data before downloading it over GPIB.



**How the Instrument Works**

---

## How the Instrument Works

### **What you'll find in this chapter**

This chapter is an overview of how the instrument works, including:

- Sequential sampling basics
- System architecture
  - plug-module hardware components
  - mainframe hardware components
  - probe selection
  - system bandwidth calculation
  - probe types
- Trigger bandwidth selection

---

## Basics of Sequential Sampling

The Agilent 83480A digital communications analyzer and Agilent 54750A digitizing oscilloscopes use digital sampling oscilloscope technology to acquire and display high bandwidth waveforms. A sampling oscilloscope does not continuously monitor the input signal applied to the channel, but looks at it only at discrete points in time. At each discrete point, the scope samples the signal and stores a replica of the input voltage on an input sampling capacitor. As shown in Figure 13-1, this sampling is done by closing a gate for a short amount of time and allowing the signal to charge the shunt capacitor through a source resistance.

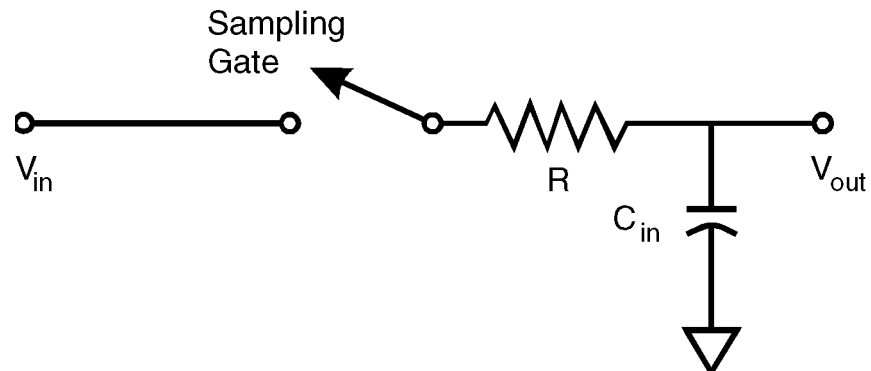

Figure 13-1. The sampling circuit.

The rate at which this capacitor charges depends on the time constant of the RC network according to the formula:

$$V_{out} = V_{in} \times \left(1 - e^{\left(\frac{-t}{RC}\right)}\right)$$

Sampling efficiency is defined as:

$$\frac{V_{out}}{V_{in}} = \left(1 - e^{\left(\frac{-t}{RC}\right)}\right)$$

The Shannon sampling theorem states that to reliably extract all the information in a signal, it must be sampled at a rate at least twice the signal's highest frequency. Using this argument, a 20 GHz signal must be digitized

### **Basics of Sequential Sampling**

at a rate at least 40 GHz; far faster than even the fastest A/D converters presently available.

To overcome the limitations of Shannon's theorem, the instrument employs a repetitive sequential sampling architecture. This approach makes use of the principle of equivalent time to display high bandwidth waveforms using a low bandwidth A/D converter. For the equivalent time approach to display valid waveforms, two conditions must be met:

1. The input signal must be repetitive.
2. A trigger signal at the same rate or a subharmonic of the input signal must be available.

Repetitive signals are necessary because the displayed trace is built up from samples taken over multiple repetitions of the waveform. (Eye diagrams, which represent statistical distributions rather than actual waveforms, are an exception to this requirement.) The trigger signal is needed to control the timing of the sampling process.

In the sequential sampling process, the input signal is sampled once per trigger event. The first trigger event in a sequence causes the input signal to be sampled at an initial delay. On the next trigger event (at a subsequent repetition of the waveform), the sampling instant is delayed by a small amount relative to the initial delay. Each additional trigger event causes the sampling instant to be delayed by greater amounts of time, so that after many triggers, the input waveform builds on the screen from left to right.

Figure 13-2 shows the sampled voltage taken over a number of trigger events. After the entire screen is filled up, the process begins a new sequence.

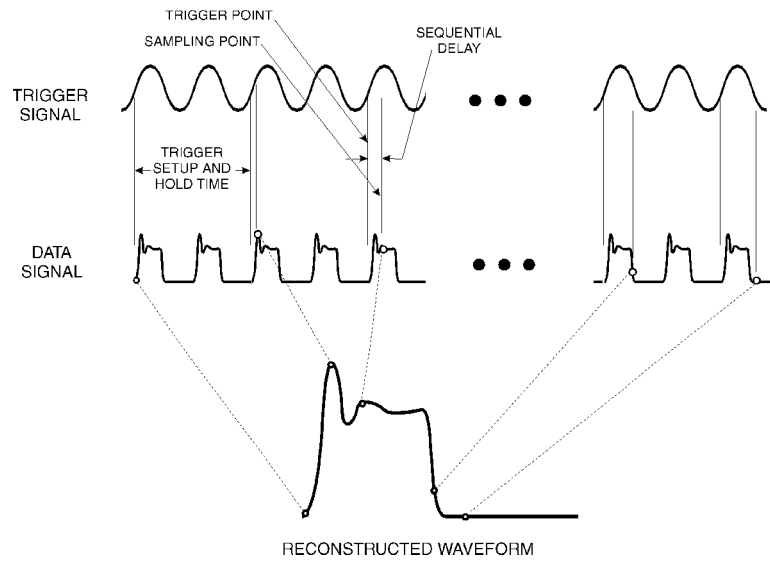

**Figure 13-2. Sequential sampling process.**

**Basics of Sequential Sampling**

The number of points in a complete acquisition sequence is known as the record length. Normally, optimum record length is automatically selected by the instrument, but it can be set manually to any value between 16 and 4096 points by selecting the Record Length softkey in the Acquisition menu. Figure 13-3 shows a waveform acquired with a record length of 64, while Figure 13-4 shows the same waveform acquired with a record length of 2250. In most cases, record length should be left on automatic. Histogram measurements, in particular, are susceptible to errors with a non-optimum record length.

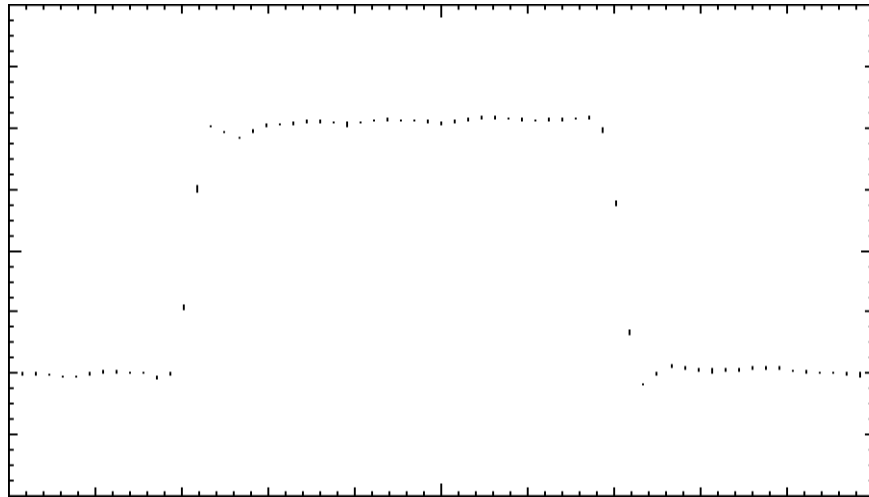

**Figure 13-3. Acquisition with record length = 64.**

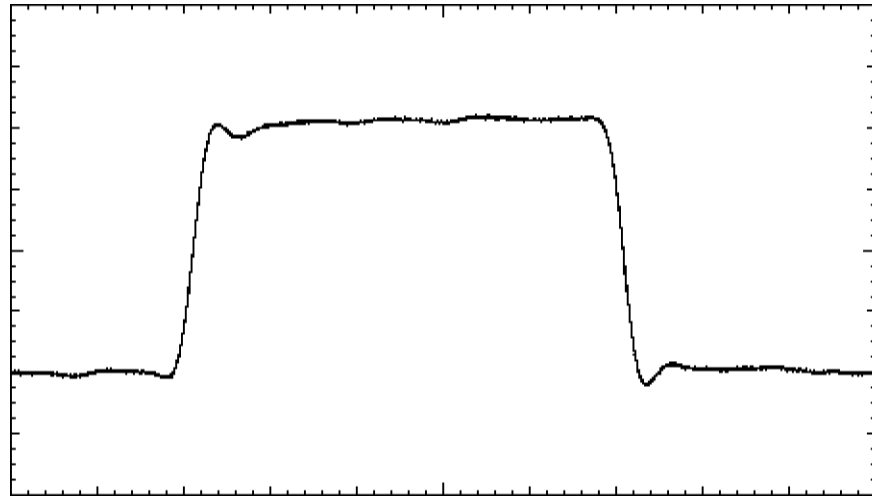

**Figure 13-4. Acquisition with record length = 2250.**

Sequential sampling cannot sample the input signal until a trigger event is received. Consequently, the actual triggered edge cannot be viewed without using a delay line. Use of a delay line compensates for internal delays in the triggering and sampling circuits within the instrument.

It can be observed from Figure 13-2 that there is an amount of time after the scope has been triggered during which it is not yet ready to accept another trigger, even if a valid trigger event occurs. This is known as trigger setup-and-hold time, which determines the maximum rate at which a signal can be acquired.

# System Architecture

A simplified block diagram of the instrument hardware architecture is shown in Figure 13-5. A complete block diagram is presented in the *Agilent 83480A, 54750A Service Guide*.

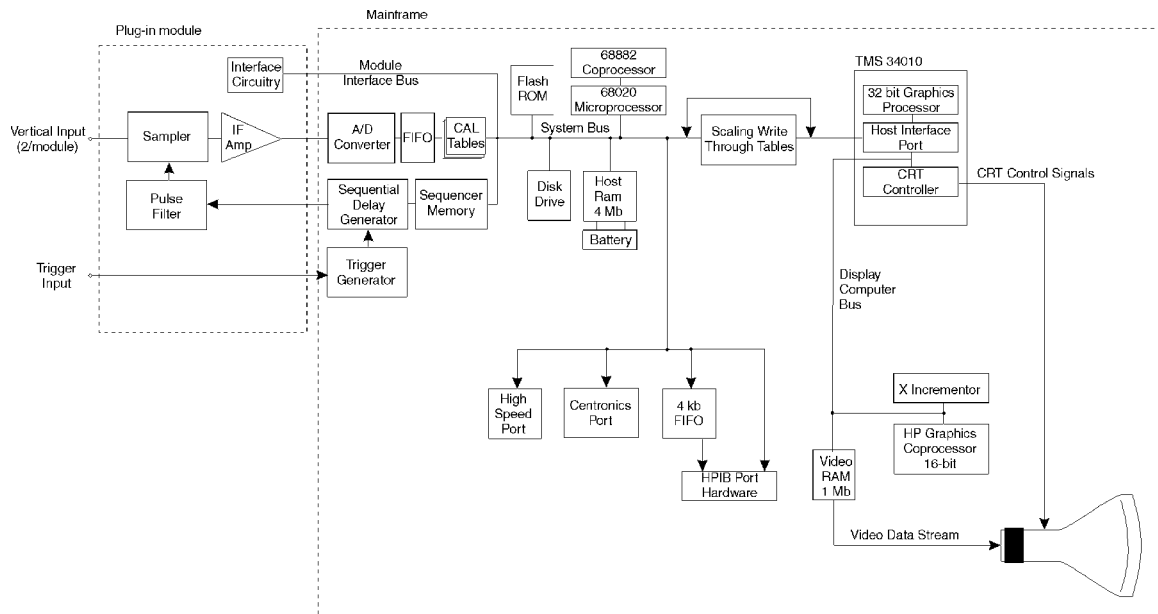

Figure 13-5. Hardware block diagram.



---

## The major plug-in module hardware components

<b>Sampler</b>	The sampler consists of a diode gate and sampling capacitor. The incoming signal is applied to the input of the diode gate, which is normally biased off. When a trigger event occurs, the pulse filter produces a pulse which momentarily forward biases the gate and allows the input signal to charge the capacitor. On an optical module, the O/E conversion and SONET/SDH filtering occur ahead of the sampler.
<b>IF AMP</b>	The IF amplifier senses the voltage on the sampling capacitor and conditions it in preparation for digitizing in the A/D converter.
<b>Trigger input</b>	The plug-in's trigger input passes the trigger signal directly into the mainframe. No trigger signal conditioning occurs within the plug-in.
<b>Pulse filter</b>	The function of the pulse filter is to transform the low repetition rate trigger pulse from the mainframe into a narrow impulse that drives the sampler. The width of this impulse must be as narrow as possible because it directly affects the bandwidth of the vertical channel.
<b>Interface circuitry</b>	The plug-in's interface circuitry accepts commands from the system microprocessor to control such module functions as IF gain, sampler bandwidth, and optical channel bandwidth. Non-volatile RAM within the module provides the system microprocessor with module cal factors, as well as information on the type of plug-in installed.

---

## The major mainframe hardware components

This section describes the major hardware components within the mainframe.

**Trigger generator**

The trigger generator receives the trigger input and sends a signal to the sequential delay generator whenever an edge meeting the trigger criteria is received, when the trigger is enabled.

**Sequential delay generator**

The sequential delay generator controls the time between when it receives a trigger input from the trigger generator and when it sends a trigger output to the pulse filter. These delay times increase sequentially with each trigger event, allowing the trace to build up from left to right across the screen. The delay values depend on the record length and timebase setting, and are programmed into the sequencer memory by the system microprocessor.

**A/D converter**

The A/D converter tracks the peak value of the analog pulse at its input and converts it to a 12-bit digital word. These 12-bit words are put into a FIFO memory which is then read and processed by the CPU.

**CAL table**

The CAL table automatically adds the calibration factors to the sampled data. The result is referred to as adjusted data, and it is sent to the system bus. The CAL table increases the throughput of the analyzer because the CPU now reads calibrated data, and does not have to explicitly correct it. This is faster than using a software solution.

**Microprocessors and coprocessors**

There are two 32-bit microprocessors, one 32-bit coprocessor, and one 16-bit coprocessor in the mainframe.

Motorola 68020 A 32-bit microprocessor that controls the system hardware, and also acts as a traffic controller on the system bus.

Motorola 68882 A 32-bit coprocessor that performs all of the floating point math.

TMS34010 A 32-bit microprocessor that draws data on the display.

HP custom graphics coprocessor A 16-bit coprocessor that controls the gray scale persistence mode, and also writes blocks of data (like the markers and display background) to the display.

<b>Host RAM</b>	The host RAM is 4 Mbytes of nonvolatile RAM. This is where the waveform data is held and manipulated. In addition, this is the location of the current front-panel setup, setup memories, and waveform memories.
<b>Flash ROM</b>	The flash ROM contains the system firmware that controls the operation of the instrument. You can load new system firmware into the instrument by using the disk drive.
<b>Disk drive</b>	The disk drive is a 3-1/2 inch, high-density, MS-DOS® compatible disk drive. You can use the disk drive to load system firmware into the flash ROMs, load applications, save screen dumps in a TIFF, GIF, or PCX format, or as additional storage space for saving waveforms and front-panel setups.
<b>User interface hardware</b>	The user interface hardware is the keyboard, and the hardware that interfaces the keyboard and knob with the system bus.
<b>FIFO and GPIB hardware</b>	The FIFO is a first-in-first-out memory that transfers waveforms through the GPIB bus under hardware control. This hardware control is much faster than the software control used by other instruments. The FIFO increases the GPIB throughput of the instrument.
<b>Centronics port</b>	The Centronics port is a parallel connector for printers compatible with the Centronics interface.
<b>High-speed port</b>	The high-speed port feature is not implemented at this time.
<b>Video RAM</b>	This is 1 MByte of fast video RAM for storing the display image. The video RAM also contains the pixel memory.
<b>Display</b>	The display is a 9-inch, high-resolution, color display. Refer to “Display” in Chapter 1 for more information.

---

## Probe selection

Two problems arise when a probe is used to connect an analyzer to a circuit.

1. The probe degrades the circuit under test. The new circuit behaves differently than the circuit without the probe. The behavior you see is the behavior of the circuit with the probe.
2. The transfer function of the probe is part of the overall measurement system response, degrading measurement accuracy.

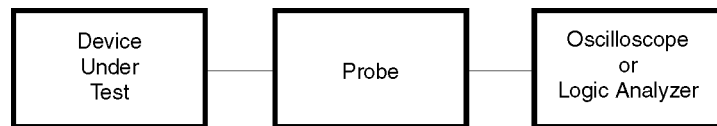

54720z01.CDR

**Figure 13-6. The probe is a part of the circuit under test.**

Suppose you are trying to debug an intermittent failure in a state machine that is implemented in high-speed CMOS logic. You know you need a high-performance digitizing analyzer, but you don't know which probe gives the best results.

There are two major factors influencing probe selection:

1. the load the probe imposes on the circuit
2. the required bandwidth of the circuit with the probe

### Probe loading

Figure 13-7 shows a simplified diagram of the circuit with the probe attached to indicate the principal loading effects. The probe load has both resistive and capacitive components. In addition to this, the inductance in the probe ground lead can cause ringing.

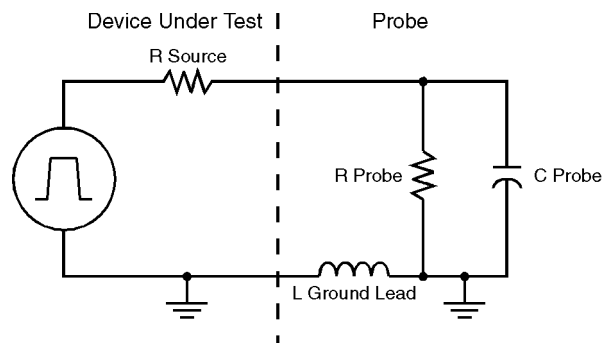

54720z02.CDR

**Figure 13-7. Simplified equivalent circuit of DUT and probe.**

**System Architecture**

The resistance of the probe to ground forms a divider network with the source resistance of the circuit under test. This reduces the signal amplitude and the dc offset. For example, if the probe's resistance is 9 times the Thevenin output resistance of the circuit under test, the amplitude is reduced by about 10 percent. Refer to Figure 13-8. The frequency-independent amplitude errors and dc offset errors introduced by probe resistive loading are approximately proportional to the ratio of the probe's resistance to ground and the equivalent output resistance of the circuit under test.

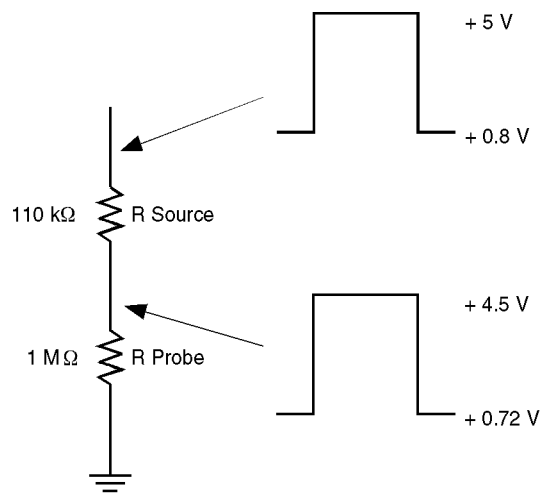

54720z03.CDR

**Figure 13-8. Reduced amplitude and dc offset caused by probe loading.**

The capacitance of the probe tip to ground forms an RC circuit with the output resistance of the circuit under test. The time constant of this RC circuit slows the rise time of any transitions, increases the slew rate, and introduces delay in the actual time of transitions. The approximate rise time of a simple RC circuit is  $2.2 RC$ . Therefore, for an output resistance of  $100\Omega$  and a probe tip capacitance of  $8\text{ pF}$ , the real rise time at the node under test cannot be faster than approximately  $1.8\text{ ns}$ , although it might be faster without the probe.

If the output of the circuit under test is current-limited (as is often the case for CMOS), the slew rate is limited by the relationship  $dV/dT = I/C$ . Refer to Figure 13-9.

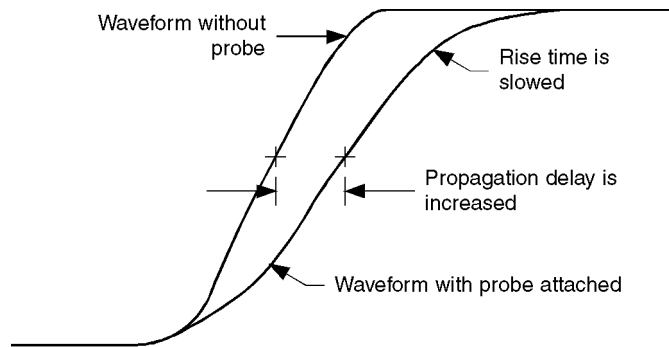

54720z04.CDR

**Figure 13-9. Effects of probe capacitance.**

### System Architecture

Perhaps you have connected an analyzer to a circuit for troubleshooting only to have the circuit operate correctly after connecting the probes. The capacitive loading of the probes can attenuate a glitch, remove ringing or overshoot, or slow an edge just enough that a setup or hold time violation no longer occurs.

The inductance of the probe ground lead forms an LC circuit with the probe's capacitance and the output capacitance of the circuit under test, including any parasitic capacitance of PC board traces, and so on. The ringing frequency of this circuit is:

$$F = \frac{1}{2\pi\sqrt{LC}}$$

If the rise time of the signal is sufficient to stimulate this ringing, then it can appear as part of the captured signal. An approximation of the bandwidth of the signal is:

$$\text{Signal Bandwidth} = \frac{0.35}{\text{Signal Rise Time}}$$

To calculate the ringing frequency, assume the probe ground wire has an inductance of approximately 25 nH per inch. Therefore, a probe with a tip capacitance of 8 pF and a 4-inch ground wire has a ringing frequency of approximately 178 MHz (not including the circuit capacitance). In this case, a signal with a rise time of less than 1.9 ns can stimulate ringing.



---

## System bandwidth

The bandwidth of the combined analyzer and probe system must be sufficient to accurately reproduce the input signal. Otherwise, time-interval measurements are inaccurate. For example, if the analyzer and probe have a combined rise time of 1 ns, and the signal also has a 1 ns rise time, the measured rise time is:

$$\sqrt{(1 \text{ ns})^2 + (1 \text{ ns})^2} = 1.41 \text{ ns}$$

The answer is in error by 41 percent.

If the analyzer and probe have a combined rise time of 330 ps, and the signal has a 1 ns rise time, the measured rise time is:

$$\sqrt{(1 \text{ ns})^2 + (330 \text{ ps})^2} = 1.05 \text{ ns}$$

Now the error is only 5 percent.

There are three rules worth memorizing.

1. The combined system rise time (analyzer and probe) should be less than 1/3 the rise time of the measured signal for an error of less than 5 percent, or less than 1/7 of the rise time of the measure signal for an error of less than 1 percent.
2. Rise time and bandwidth are inversely related as shown in the preceding equations.
3. Rise times add approximately as the square root of the sum of the squares.

The wide bandwidth of the analyzer compared to the bandwidth of a typical probe means that, for most cases, the combined bandwidth can be assumed to be the same as that of the probe alone.

## Probe types

There are two common types of probes suitable for use with the Agilent 83480A, 54750A. Each type has different loading effects. There is the low-impedance resistive divider probe, like the Agilent 54006A, and there is the active probe, like the Agilent 54701A. A third type of probe, the compensated high resistance passive divider probe, is designed for use with 1 M $\Omega$  inputs and is *not* suitable for use with the Agilent 83480-series digital communications analyzer.

**Resistive divider probes** Resistive divider probes are designed for analyzers with a 50 $\Omega$  input impedance. The tip of the probe has a 450 $\Omega$  or 950 $\Omega$  series resistor. The cable is designed for a 50 $\Omega$  transmission line. Because the cable is terminated in 50 $\Omega$  at the analyzer input, it looks like a purely resistive 50 $\Omega$  load when viewed from the tip. Therefore the resistive divider is flat over a wide range of frequencies, limited primarily by the parasitic capacitance and inductance of the 450 $\Omega$  or 950 $\Omega$  resistor and the fixture that holds it. The input resistance of the probe to the circuit under test is either 500 $\Omega$  or 1 k $\Omega$ .

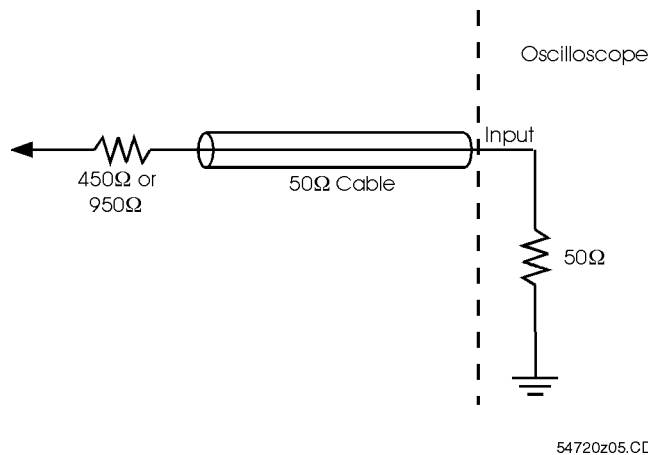

Figure 13-10. Resistive divider probe.

Because of the physical geometry of this type of probe and because the divider does not have to be capacitively compensated, this type of probe has the lowest capacitive loading of any probe. This low capacitance and its inherent wide bandwidth make it best suited for wide bandwidth measurements or those measurements where timing is the most critical parameter.

The disadvantage of this type of probe is its relatively heavy resistive loading. Not all circuits can drive  $500\Omega$  or  $1\text{ k}\Omega$ . Even for measurements in a relatively low impedance circuit, the amplitude errors can be significant. Changes in bias levels or operating current in the circuit under test might affect the circuit's behavior.

This type of probe is the best choice for minimum disturbance probing of ECL circuits and  $50\Omega$  transmission lines. The  $1\text{ k}\Omega$  divider probes are also usually suitable for high-speed CMOS circuits. If you are interested in troubleshooting CMOS, consult the data sheet for the particular CMOS part to make sure that it can drive a  $1\text{ k}\Omega$  load and to determine what the voltage error would be.

#### **Active probes**

An active probe, like the Agilent 54701A, has a buffer amplifier at the tip. Refer to Figure 13-11. This buffer amplifier drives a  $50\Omega$  cable terminated in  $50\Omega$  at the analyzer input. Active probes offer the best overall combination of resistive loading, capacitive loading, and bandwidth, even though an active probe does not have the highest resistance, highest bandwidth, or lowest capacitance available. The disadvantages of active probes, besides their higher cost, are the larger size of the tip and a somewhat limited input dynamic range. Previous active probe designs were more susceptible to damage, particularly to ESD, and required careful handling. The Agilent 54701A is designed to withstand 200 V peak ac and 12 kV of ESD, so it functions reliably in adverse conditions.

**System Architecture**

The Agilent 54701A has sufficient bandwidth (2.5 GHz), sufficiently small capacitive loading (0.6 pF), and sufficiently high resistance (100 k $\Omega$ ) to be useful for both ECL and CMOS circuits, and for most analog circuits.

For the high-speed CMOS state machine in the example, the Agilent 54701A active probe offers the best combination of measurement accuracy with minimal circuit loading.

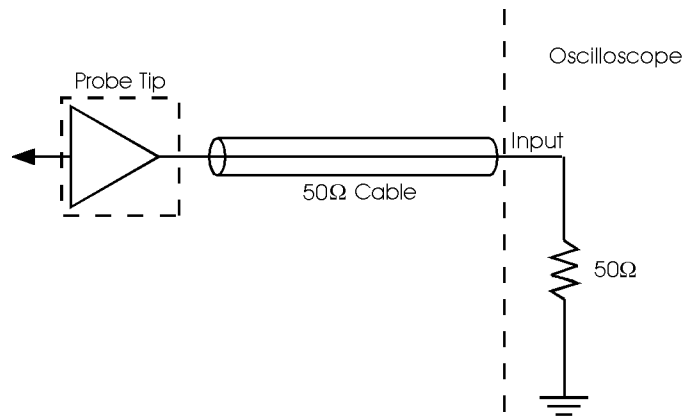

54720z08.cdr

**Figure 13-11. Active probe.**

---

## Summary

There is no such thing as the perfect probe, so you must use some discretion in choosing the best type of probe for each measurement.

To make the correct choice, it's helpful to know the equivalent circuit of the circuit under test. For truly demanding measurements, it may be worthwhile to simulate the effect of the probe using SPICE. This discussion assumes a simple resistance as the equivalent circuit for the circuit under test. For an actual measurement, a more complete model is useful in evaluating the effects of the probe.

Some knowledge of the expected signal, particularly its rise time or spectral content, is also useful in making a probe choice. Finally, it's important to know what parameter (voltage or time) you need to measure most accurately, because some tradeoff is almost always required.

---

## Standard and Enhanced Trigger Modes

The standard Agilent 83480A trigger has two bandwidth modes, **DC-2.5 GHz** and **DC-100 MHz**. The Agilent 83480A Option 100 adds two enhanced bandwidth modes, **2-12 GHz** and **2-12 GHz Gate**. This section describes each mode and its applications.

---

### DC-2.5 GHz mode

The DC-2.5 GHz mode is much like a traditional analog oscilloscope trigger. It is DC coupled with an adjustable threshold level from  $-1.0$  V to  $1.0$  V. Either the positive or negative transition can be selected. There is a freerun mode that allows the user to see the signal amplitude before a trigger has been established. There is also a high sensitivity setting that reduces trigger hysteresis for low-level, and low noise, signals.

The DC-2.5 GHz mode is used for the majority of applications because it provides excellent performance for trigger signals up to 2.5 GHz and has the most user-selectable options. Select this mode whenever eyeline measurements are made.

---

### DC-100 MHz mode

The DC-100 MHz mode adds a low-pass filter to the trigger path. This mode is used for noisy low frequency trigger signals, because it can be used to reject high frequency noise. DC-100 MHz mode allows more accurate triggering in these applications, but will reduce the effective trigger bandwidth to approximately 100 MHz.

---

## 2-12 GHz mode (Option 100 only)

The 2-12 GHz enhanced bandwidth mode allows direct triggering on signals with wider bandwidth. This mode is useful with Agilent 83480A plug-in modules that display signals with up to 50 GHz bandwidth. The 2-12 GHz mode increases the bandwidth capabilities but may, in some instances, reduce the significance of the displayed data. In this mode, there is no control over the trigger level or slope.

In the 2-12 GHz mode, a high-speed IC is used to divide the incoming signal frequency by a factor of 16. This divided signal is applied to the existing trigger circuitry. The trigger input is AC-coupled to the divider IC. The input threshold of the IC is set for maximum sensitivity and bandwidth, and it will operate correctly on a sine wave input from 2 GHz to 12 GHz. Typically, the upper frequency limit is 15 GHz for 200 mV p-p sine wave inputs. Square wave triggers, or other sharp-edged transitions will function down to DC, but this is not specified because it depends on the characteristics of the signal edges. In the 2-12 GHz mode there is no control over the trigger level or the slope.

If no trigger signal is applied, the divider self-oscillates, providing a freerun trigger for the oscilloscope. When a trigger signal is applied, the divider will recognize it and provide a stable reference. No adjustments to sensitivity are provided, because the circuit will operate correctly for any signal between the 200 mV minimum and the 2 V maximum. Under these conditions, the trigger timing jitter is specified to be less than 2 ps rms for small time delays. The divider provides an output transition to the trigger circuit every 16<sup>th</sup> input cycle. However, since the analyzer samples at a maximum rate of 40 kHz, not every output of the divider is recognized as a valid trigger event.

One typical application of the 2-12 GHz trigger mode would be viewing a 10 Gb/s eye diagram with a recovered 10 GHz clock as shown in Figure 13-12.

**Standard and Enhanced Trigger Modes**

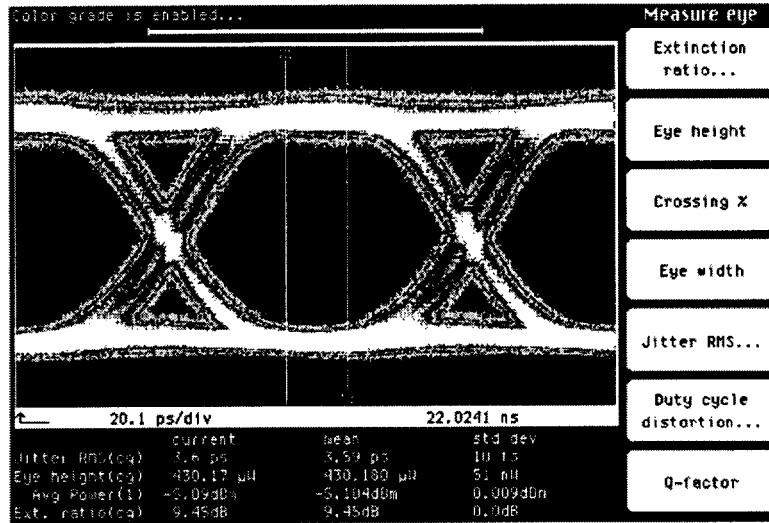

**Figure 13-12. Viewing a 10 Gb/s eye diagram using 12 GHz trigger.**

An eye diagram usually consists of the overlay of samples from many different bits of a random (or pseudo-random with length  $2^{n-1}$ ) digital signal. Therefore, the fact that the trigger only recognizes every sixteenth event will not reduce the significance of the data.

However, if viewing a signal with a pattern length of modulus 16 (where the number of trigger transitions is an integer multiple of 16), the analyzer will only acquire data from certain bits, which will reduce the significance of the data. PRBS signals are of odd length, so this is usually not a problem.



---

## 12 GHz/Gate mode (Option 100 only)

The 2-12 GHz Gate mode will trigger selectively on distinct groups of high speed signals. It is the most complex trigger mode of the analyzer and is primarily intended for experienced users.

As in the 2-12 GHz mode, a high-speed IC is used to divide the incoming signal frequency by a factor of 16. This divided signal is applied to the existing trigger circuitry. The trigger input is AC-coupled to the divider IC.

A low speed (<1 MHz maximum frequency) TTL level gating signal is applied to a BNC connector on the rear panel of the analyzer. Only when that signal is at a logical high will the trigger divider recognize input transitions. Because the speed of the gating function is much less than that of the trigger input, there must be some significant separation of the desired and excluded trigger signals. This mode, if used to separate out individual segments of a continuous trigger, will result in trigger artifacts. Refer to the Trigger Artifacts section later in this chapter for additional information. The gate mode allows measurements of signals that previously were difficult, or even impossible, to view. However, there are significant tradeoffs. The rest of this section discusses the tradeoffs and offers suggestions on how to minimize their impact,

### **Trigger sensitivity**

In the gate mode, the analyzer should only trigger when both the gate enable signal is present and a trigger transition occurs. Therefore, the free running effect of the divided trigger is suppressed by biasing the divider IC to prevent self-oscillation. This reduces the sensitivity of the trigger. In the standard divided mode, the jitter is specified as 2 ps rms from 2 GHz to 12 GHz with a 200 mV p-p sine wave input. See Figure 13-13.

**Standard and Enhanced Trigger Modes**

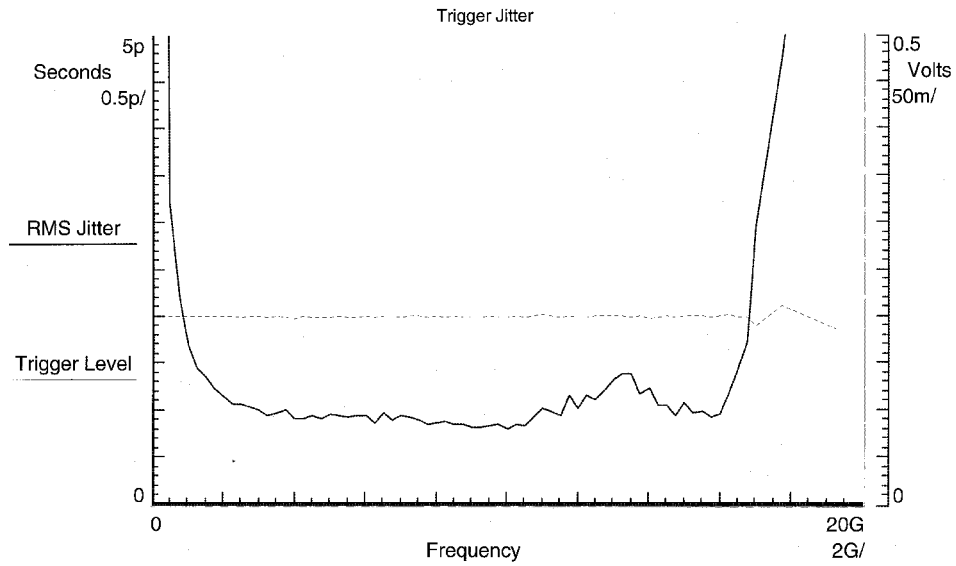

**Figure 13-13. 12 GHz mode jitter with 200 mV p-p sine wave input.**

In gate mode, the typical frequency range is 2 to 12 GHz and the sensitivity is reduced, requiring a 300 mV p-p sine wave input. See Figure 13-14.

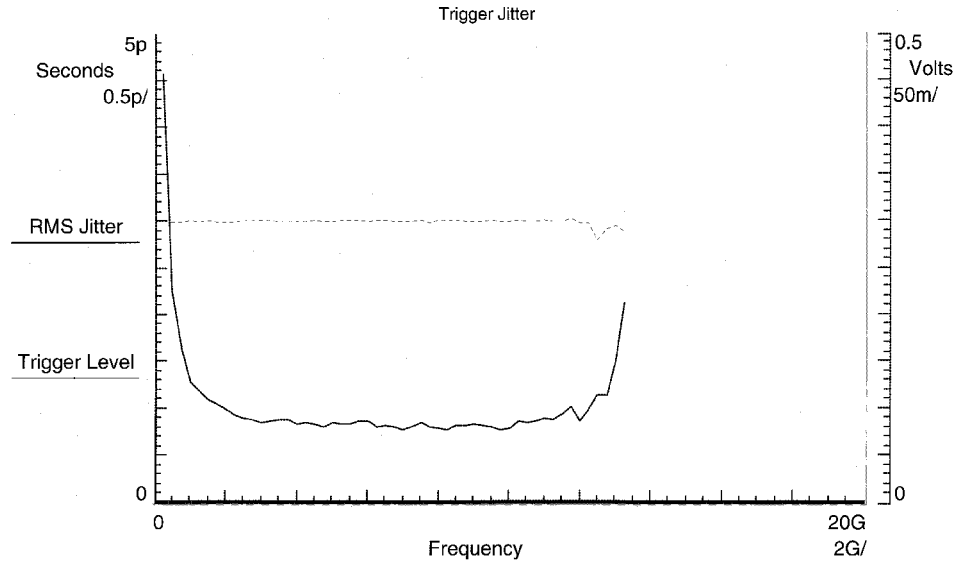
**Standard and Enhanced Trigger Modes**

**Figure 13-14. 12 GHz/Gate mode jitter with 300 mV p-p sine wave input.**

**Gate input voltage requirements**

The gating input requires a TTL signal (nominally 0 to 5V). Input transition thresholds are typically 1.3 V.

**Gate timing parameters**

While the gated trigger does not have warranted specifications, the following characteristics are provided as a guide for the user. Three timing parameters are key to understanding trigger gating:  $t_{\text{setup}}$ ,  $t_{\text{width}}$ , and  $t_{\text{delay}}$ :

$T_{\text{setup}}$	the delay between a gate enable, positive edge, and the first trigger event that will be recognized. This delay is typically 250 ns.
$T_{\text{width}}$	the width of the gate enable pulse. This should typically be at least 300 ns but may be as long as desired.
$T_{\text{delay}}$	the minimum time after the gate is disabled before the trigger transitions are ignored. This typically requires 850 ns. Therefore, trigger gating can be used to select, at a minimum, approximately one microsecond intervals of time from an input signal. There is no maximum time between gate enable pulses.

**Standard and Enhanced Trigger Modes****Example of gating**

Figure 13-15 shows an application of the gate mode and illustrates the Tsetup, Twidth, and Tdelay parameters. In this case, pairs of 10 GHz RF bursts are emitted with a 2  $\mu$ s spacing. It is desired to trigger on every other burst. Both the gate and RF signals have been delayed in time so that both waveforms can be shown on the display. Notice that the delay between the positive edge of the gate signal and the triggering of the 10 GHz RF burst is approximately 250 ns. This delay (Tsetup parameter) was explained in the preceding paragraphs. Because the sweep speed is relatively slow, the second RF burst can be seen on screen; however, the trigger point is stable at the beginning of the first pulse.

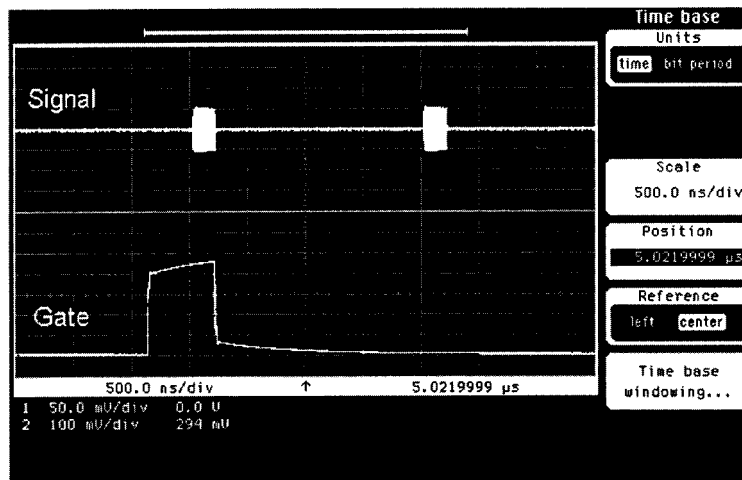

**Figure 13-15. Gating application.**

**Trigger artifacts**

There are two major types of artifacts that can cause confusion when using the gated trigger; Modulus 16 Effect and Gate Enable False Triggers. Both are related to the use of a divider IC.

**Modulus 16 Effect**

Because the trigger divider IC is not reset by the gating input, the actual trigger could take place on any of the first 16 input transitions after the gate enable setup time. Figure 13-16 and Figure 13-17 demonstrate this effect on a signal with pulsed RF content. In Figure 13-16, the signal has a 2 GHz carrier. The standard trigger is used and the display clearly shows both the pulse envelope and the carrier.

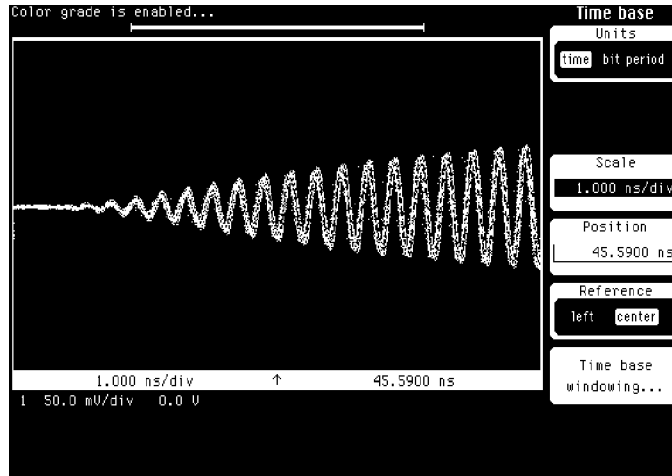

Figure 13-16. 2.5 GHz trigger on signal with pulsed 2 GHz RF content.

In Figure 13-17, the carrier modulation is increased to 10 GHz (with an expanded time scale). At this point the 2.5 GHz trigger mode is not fast enough, so the 12 GHz/Gate mode is used.

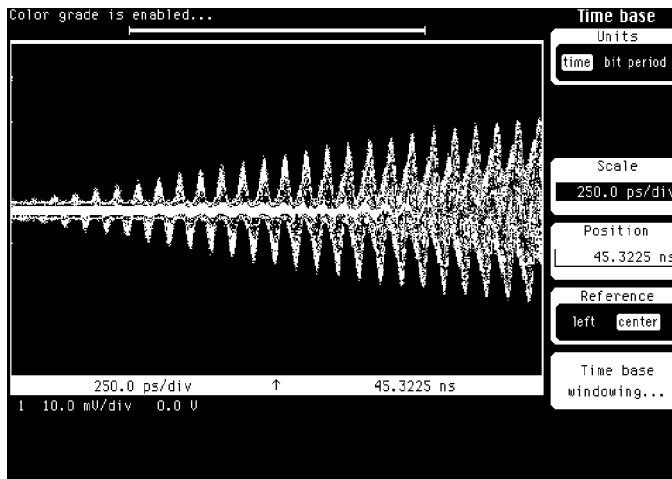

Figure 13-17. 12 GHz trigger on signal with pulsed 10 GHz RF content.

### Standard and Enhanced Trigger Modes

Figure 13-17 shows the effect of the modulus 16 trigger, where the carrier within the envelope is “smeared” because the trigger may occur on any of the first sixteen carrier cycles. However, the envelope information is still visible.

For some signals, such as eye diagrams, this effect is not important. In other cases, it may be possible to adjust the signal to be of modulus 16 so that the trigger is stationary.

### Gate Enable False Triggers

In this gating architecture, if the trigger input is high when the gate enable is asserted, there is a finite chance that a false analyzer trigger will result.

For example, Figure 13-18 shows a 10 Gb/s digital eye diagram without using gating and Figure 13-19 shows the same signal using a 1 ms gating pulse.

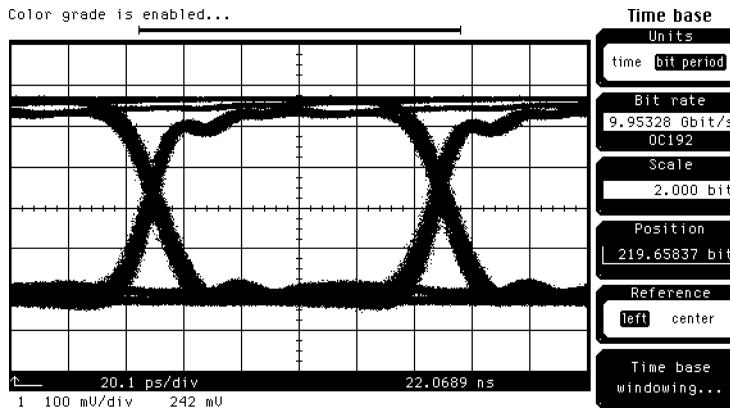
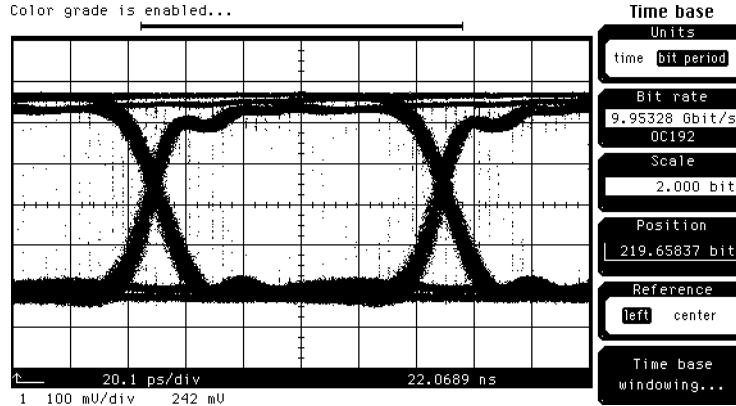

Figure 13-18. 10 Gb/s digital eye diagram without gating.

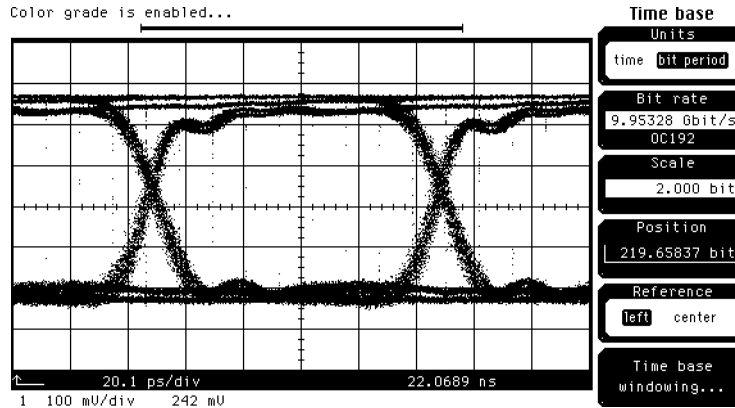

**Figure 13-19. 10 Gb/s digital eye diagram with a 1ms gating pulse.**

Note the appearance of unexpected data points within the eye. These are the result of false triggers on the gate enable rising edge.

Since the gating signal is completely asynchronous with the trigger signal, the required condition for false triggers occurs frequently. The number of false triggers can be reduced by synchronizing the gate enable rising edge with the clock. If one could ensure that the gate enable would only be asserted when the trigger input was low, no false triggers would occur. Figure 13-20 shows the result of triggering the low speed gating pulse generator from the 10 Gb/s pattern generator.

## How the Instrument Works



**Figure 13-20.**

**Result of triggering the low speed gating pulse generator from the 10 Gb/s pattern generator.**

Note that the number of false triggers is reduced but not completely eliminated. This is because the inherent jitter of low speed pulse generators makes it difficult to ensure that the gate enable edge is stable within a 10 Gb/s clock cycle. It may be possible, in some experimental setups, to generate coherent and stable gate enable signals more directly from the trigger signal and achieve better results.

While the 12 GHz/Gate mode allows triggering on complex and high speed signals, care must be taken during experimental setups and when interpreting the results.



---

---

# Index

---

# Index

- 0** 0 level (Y1) (mask test) softkey, 6-20
  
- 1** 10%, 50%, 90% (define measure) softkey, 10-9  
+15 V, 150 mA input, 1-17  
1 level (Y2) (mask test) softkey, 6-20
  
- 2** 20%, 50%, 80% (define measure) softkey, 10-9  
2-12 GHz Gate, 6-54, 10-64  
2-12 GHz Gate (trigger) softkey, 13-25  
2-12 GHz softkey, 6-53, 10-64  
2-12 GHz (trigger) softkey, 13-23
  
- A** absolute voltage level measurement, 7-7  
accessories, 1-5, 1-6  
accuracy and resolution, 9-4  
acquisition
  - channel, 9-5
  - menu, 10-3-6
  - status, 1-14active probes, 13-19  
ac Vrms, 7-15  
A/D converter, 13-10  
add (math) softkey, 10-48  
Add to memory (waveform) softkey, 11-98  
Agilent Technologies Sales and Service Offices, xii  
algorithm
  - measurement, 5-5, 7-8, 10-8
  - threshold detection, 10-10aliasing, FFT, 10-35  
Align Mode (mask test) softkey, 6-22  
altitude, 3-6  
AMI (alternate mask inversion), 10-16  
amplitude
  - display, 1-10
  - measurement, 10-11
  - measurement, FFT, 10-32analog circuit measurement, 1-3  
Apple Macintosh file conversion, 11-77  
architecture, 13-8  
armed light, 1-14

- Automask (mask test) softkey, 6-7
  - Automatic (acquisition) mode, 10-6
  - automatic measurement, 1-12, 8-3-22, 9-4, 10-14, 11-56
    - marker, 11-61
      - pulse parameters, 9-4
  - automatic record length, 10-6
  - Autoscale key, 1-10
  - average frequency measurement, 8-3
  - Averaging (acquisition) softkey, 10-4
  - Avg Power (general meas) softkey, 8-14
  - Avg Power Menu, 8-13-14
  - Axis (histogram) softkey, 10-40
- B**
- Background (setup print) softkey, 11-74
  - bandwidth, system, 13-17
  - Bandwidth/wavelength (eye) softkey, 5-7
  - Bandwidth/wavelength (mask) softkey, 5-29
  - base level algorithm, 9-4
  - base voltage value, 10-12
  - base waveform measurement, 7-8
  - Best (acquisition) softkey, 10-5
  - binary file format, 11-14
  - bit period, 5-7, 5-30
    - units, 6-45, 10-54
  - bit rate, 5-30
    - masks, 5-26
  - Bit rate (eye) softkey, 5-7
  - Bit rate (mask) softkey, 5-30
  - Bit Rate (time base) softkey, 6-45, 10-54
  - blue labeled functions, 5-9
  - building a histogram, 7-6-9
  - building the database, 10-37
  - bw limit (math) softkey, 10-50
- C**
- cables, 9-14
  - calculating threshold level, 7-10
  - calculating top and base of the waveform, 7-8
  - Calibrate Frame (utility) softkey, 11-85
  - Calibrate Plug-in (utility) softkey, 11-85
  - Calibrate (utility) softkey, 11-85
  - calibration
    - external scale, 4-16
    - factory, 4-4
    - mainframe, 4-4
    - O/E, 4-6
    - O/E converters, 4-16
    - O/E user wavelength, 4-10

- offset zero, 4-13
- overview, 4-2
- plug-in module vertical calibration, 4-12
- probe, 4-17
- probes, 4-16
- skew, 4-16
- user, 4-8
- voltage probe, 4-17
- CAL signal output, 11-88
- Cal Status (utility) softkey, 11-86
- CAL table, 13-10
- capabilities, performance, 3-2
- capacitive loading, 9-18
- capturing error trace, 5-42
- Center Freq (FFT) softkey, 10-26
- Centronics port, 13-11
- Centronics (setup print) softkey, 11-74
- certification, vii
- channel
  - setup, 6-43, 10-7
- Channel Autoscale (channel) softkey, 1-10
- Channel Autoscale (eye) softkey, 5-7
- Channel Autoscale (mask) softkey, 5-29
- Channel (channel setup) key, 6-43
- Channel (define measure) softkey, 10-11
- Channel (eye) key, 5-7
- Channel key, 10-7
- Channel (mask) key, 5-29
- Channel Settings display, 1-12
- Channel Setup menu, 6-43, 10-7
- channel-to-channel measurement, 9-5
- characteristics, performance, 3-2
- circuit measurement, 1-3
- Clear Display (control) key, 2-3
- Clear memory (waveform) softkey, 11-98
- clock signal, 5-29, 5-39
- Clr meas softkey, 1-12
- CMI (coded mark inversion), 10-16
- Color (display) softkey, 11-38
- color graded
  - database, 7-8, 7-16
  - display, 5-11, 6-6, 10-6, 10-37
  - histogram mode, 5-3
- Color Grade (define measure) softkey, 10-16
- Color grade (disk) softkey, 11-12
- Color grade (display) softkey, 11-27
- color menu selection, 11-38
- Column (display) softkey, 11-35, 11-37
- comparing measurement results, 11-42

- computing dBm, FFT, 10-33
- condensation, 3-6
- connected dots (display) softkey, 11-28
- connection devices, 1-6
- connector care, xvii
  - cleaning, xix
  - handling, xix
  - non-lensed, xx
- connector interface
  - compatibility, xxi
  - insertion technique, xxi
  - torque requirements, xxi
- constructing polygons, 6-5
- converting TIFF and GIF files, 11-77
- counter saturation level, 6-6
- Create mask (mask test) softkey, 6-7
- Create mask softkey, 5-33, 5-34
- Create (mask test) softkey, 6-8
- creating a polygon, 6-14
- crossing %, 5-14
- Crossing % (eye) softkey, 5-14
- Crossing % (measure eye) softkey, 6-36
- crossing points
  - location, 7-9
  - mean location, 6-38
  - time location variance, 6-39
- Current memory (waveform) softkey, 11-94
- customer assistance, xii, 12-2-6
- custom masks, 6-19
- custom measurements, 11-56

**D** Dark Cal (eye) softkey, 5-11

Dark cal (measure eye) softkey, 6-33

data
 

- acquisition, 2-7-8, 10-37, 10-45
- collection, 7-5
- display, 11-24
- record, 7-4

database memory area, 10-37

Data (setup disk) softkey, 11-76

date and time, 11-82

Date (utility) softkey, 11-82

DC-100 MHz softkey, 6-53, 10-64

DC-100 MHz (trigger) softkey, 13-22

DC-2.5 GHz softkey, 6-53, 10-64

DC-2.5 GHz (trigger) softkey, 13-22

dc errors, 9-9-13

dc Vrms, 7-15

declaration of conformity, ix  
declassifying frame memory, 11-83  
deep memory feature, 8-3  
Default Colors (display) softkey, 11-41  
Default scale (mask test) softkey, 6-20  
default setup settings, 11-66  
Default setup (setup) softkey, 11-66  
Define Function (math) softkey, 10-47  
Define meas (eye) key, 5-13  
Define Meas menu, 9-4-5  
Define Measure (define measure) softkey, 10-11  
Define Measure menu, 7-8, 10-8  
Define New Label (display) softkey, 11-34  
Define  $\Delta$ time (define measure) softkey, 10-14  
Degauss, 1-17  
Delay, automatic measurement, 9-4  
delete (disk) softkey, 11-10  
Delete (display) softkey, 11-37, 11-38  
Delete Mask (mask test) softkey, 6-13  
Delete (mask test) softkey, 6-13  
Delete Polygon (mask test) softkey, 6-13  
delta time measurement, 7-7  
Destination (mask test) softkey, 6-26, 6-27  
Destination (setup print) softkey, 11-74  
determining rising and falling edges, 7-11  
differentiate (math) softkey, 10-49  
digital circuit measurement, 1-3  
directory (disk) softkey, 11-4  
disk drive, 13-11  
disk file extensions, 11-8  
Disk (limit test) softkey, 11-51, 11-54-55  
Disk (mask test) softkey, 6-26-29  
Disk menu, 11-3-23  
Disk (setup print) softkey, 11-75  
display, 1-11, 13-11  
Display (display) softkey, 11-34  
Display (eye) softkey, 5-7  
Display (FFT) softkey, 10-23  
Display (mask) softkey, 5-29  
Display (math) softkey, 10-51  
Display menu, 11-24-41  
display visual reference, 11-56  
Display (waveform) softkey, 11-95, 11-98  
distortion, duty cycle, 5-17  
divide (math) softkey, 10-48  
divisions of vertical scale, 5-5  
draw waveform (display) softkey, 11-27  
DutCycDist (eye) softkey, 5-17  
duty cycle

- display, 1-10
- distortion, 5-17, 6-40
- signal, 7-8
- timing measurement, 7-18
- Duty cycle distortion (measure eye) softkey, 6-40
- Duty Cycle softkey, 8-6
- dynamic response errors, 9-9, 9-14

**E** Edge Number (define measure) softkey, 10-15  
Edge Threshold (define measure) softkey, 10-15  
editing a polygon, 6-16  
Edit Mask (mask test) softkey, 6-10  
Edit polygon (mask test) softkey, 6-11  
electrical masks, 6-4, 6-9  
electrostatic discharge, xiv  
Enable Failure (mask test) softkey, 6-25  
entry devices, 1-13  
error

- messages, 11-15, 12-2
- probability, 9-5
- pulse height measurement, 9-17
- pulse width measurement, 9-18
- rise time measurement, 9-15
- vertical channel, 9-9

error detector, 5-43  
error trace capture, 5-42, 5-49-52

- display state, 5-51

ESD

- reducing damage caused by ESD, xvi
- static-safe work station, xiv

external scale calibration, 4-16  
External Scale (trigger) softkey, 6-52, 10-62  
external trigger, 1-10  
extinction ratio, 5-10

- calibration routine, 6-33

Extinction ratio (measure eye) softkey, 6-32  
Ext ratio (eye) softkey, 5-11  
eye

- mode, 5-47
- parameter measurement, 5-46

eye diagram, 5-38, 7-4

- figure of merit, 6-41
- horizontal opening measure, 6-38
- measurement, 5-3-24
- vertical histogram, 6-35

Eye height (measure eye) softkey, 6-35  
Eye height softkey, 5-13  
eyeline

- firmware limitations, 5-46
- front and rear panel connections, 5-43
- mode, 5-47
- program operation, 5-44
- software, 5-37-52
- software installation, 5-47
- trace averaging, 5-48
- traces, 5-38
- eye measurement, 8-4
  - display, 5-9
  - overview, 6-30
- eye width, 5-15
- Eye width (measure eye) softkey, 6-38
- Eye width softkey, 5-15
- eye window, 6-32
- Eye window 1 (define measure) softkey, 10-17
- Eye window 2 (define measure) softkey, 10-17

**F**

- Factors (setup print) softkey, 11-76
- factory calibration, 4-4
- Fail Action (limit test) softkey, 11-50
- Fail action (mask test) softkey, 6-25
- Fail Always (limit test) softkey, 11-45
- Failed Samples (mask test) softkey, 6-23
- Failed wfms (mask test) softkey, 6-23
- Fail Inside (limit test) softkey, 11-45
- Fail (limit test) softkey, 11-46
- Fail Never (limit test) softkey, 11-45
- Fail Outside (limit test) softkey, 11-45
- Failures (limit test) softkey, 11-48
- failure test results summary, 11-50
- Fail When (limit test) softkey, 11-45
- falling edge
  - determination, 7-11
  - measurement, 8-4
- fall time, 5-23
  - measurement, 7-7, 7-17, 8-4
- Fall Time softkey, 8-7
- fast (display) softkey, 11-28
- FFT
  - aliasing, 10-35
  - amplitude measurements, 10-32
  - automatic measurements, 10-28
  - basics, 10-28
  - computing dBm, 10-33
  - computing dBV, 10-34
  - frequency accuracy, 10-31
  - frequency measurements, 10-31



- presetting parameters, 10-35
- FFT freq (freq domain) softkey, 8-15
- FFT mag (freq domain) softkey, 8-15
- FFT magnitude, 10-51-52
- FFT Magnitude (math) softkey, 10-50
- FFT menu overview, 10-22
- FFT Scaling (FFT) softkey, 10-25
- FFT  $\Delta$ freq (freq domain) softkey, 8-16
- FFT  $\Delta$ mag (freq domain) softkey, 8-16
- fiber ends
  - inspection, xxiii
- FIFO hardware, 13-11
- figure of merit, 6-41
- file
  - extensions, 11-8
  - field function, 11-22
  - format, 11-14
- File Name (disk) softkey, 11-22
- Fill display (mask test) softkey, 6-22
- Filter (eye) softkey, 5-7
- Filter (mask) softkey, 5-29
- Fine (system) softkey, 2-4
- firmware
  - request form, 11-89
  - updating, 11-84
- Firmware Support (utility) softkey, 11-89
- fixed margin test, 5-34
- fixed voltage masks, 6-4
- flash ROM, 13-11
- Forever (limit test) softkey, 11-48
- Forever (mask test) softkey, 6-23
- format (disk) softkey, 11-10
- Format (disk) softkey, 11-14
- Format (eye) softkey, 5-11, 5-16
- Format (setup print) softkey, 11-73
- Form Feed (setup print) softkey, 11-73
- frame
  - display box, 11-81
  - memory declassifying, 11-83
  - screen mode, 11-31
- frame (display) softkey, 11-32
- freerun threshold, 1-14
- Free Run (trigger) softkey, 6-51, 10-61
- Freq Domain menu, 8-14-18
- frequency
  - accuracy, FFT, 10-31
  - display, 1-10
  - measurement, 7-4, 7-7, 7-10, 8-3
  - measurements, FFT, 10-31

- timing measurement, 7-17
- Frequency softkey, 8-7
- From File (disk) softkey, 11-22
- From waveform (waveform) softkey, 11-95
- front panel
  - CAL signal output, 11-88
  - eyeline connections, 5-43
  - features, 1-9
  - interface, 5-44
  - keys, 1-7, 10-2-64
  - Measure area, 9-19
  - measure section, 8-5-10
  - setup, 11-12, 11-64
  - Setup area, 6-54
- Function (define measure) softkey, 10-11
- Function (math) softkey, 10-47
- Function Scaling (math) softkey, 10-52
- fuse, 1-16

**G** Gaussian distribution, 10-20

- General Meas (define measure) softkey, 10-11
- General Meas menu, 8-10-13
- general specifications, 3-6
- generating a mask, 5-33
- GIF files, converting, 11-77
- GPIB, 5-43
  - connector, 1-16
  - hardware, 13-11
- Graphs (display) softkey, 11-33
- Graticule area display, 1-12
- Graticule (display) softkey, 11-31
- Graticule (setup print) softkey, 11-76
- gray scaling, 11-25
- grid (display) softkey, 11-31
- grid screen mode, 11-31

**H** hardware architecture, 13-8

- hardware components
  - mainframe, 13-10-11
  - plug-in module, 13-9
- header information, 11-15, 11-19
- Help menu, 2-5
- Help (system) key, 2-5
- high resolution (display) softkey, 11-30
- high speed data port, 1-17
- histogram, 1-13, 6-6, 7-4, 7-6-9, 10-37
  - color graded, 5-3, 7-8, 7-16
  - horizontal, 6-36

- horizontal markers, 10-42
- statistics, 10-39
- vertical, 6-36
- vertical markers, 10-42
- waveform, 10-6
- Histogram (histogram) softkey, 10-36
- histogram (marker) softkey, 11-62
- Histogram menu, 8-18-22
- Histogram Scale (histogram) softkey, 10-43
- Histogram Window (histogram) softkey, 10-41
- hits (histogram) softkey, 8-20
- hold time measurement, 9-5
- horizontal
  - axis, 10-45
  - display, 1-10, 10-40
  - histogram, 6-36, 10-36
  - marker, 10-42, 11-59
  - scale, 5-7, 5-30
  - scaling factors, 11-55
  - standard deviation, 5-15
  - time histogram, 7-4
  - tolerance of reference waveform, 6-8
- Horizontal (math) softkey, 10-52
- horizontal system specifications, 3-3
- host RAM, 13-11
- HP-IB (setup print) softkey, 11-74
- HP-IB Setup (utility) softkey, 11-79
- Hue (display) softkey, 11-40
- humidity, 3-6
- Hysteresis (trigger) softkey, 6-53, 10-63

**I** IF amp, 13-9

- Ignore (limit test) softkey, 11-46
- incomplete transitions, 7-12
- increasing measurement accuracy, 9-3-8, 9-19
- indicator lights, 1-14
- infinite (display) softkey, 11-26
- infinite persistence, 5-51, 11-26
- input voltage time changes, 9-14
- insertion loss
  - testing, xxiii
- Insert (mask test) softkey, 6-13
- instrument
  - display, 1-11
  - messages, 12-2
  - overview, 1-3, 13-2
- integrate (math) softkey, 10-49
- Intensity (display) softkey, 11-32

interface circuitry, 13-9  
internal  
  file format, 11-11  
  noise signals, 6-33  
  offset, 5-10  
  voltage level, 7-6  
Internal (disk) softkey, 11-14  
invert (math) softkey, 10-48

**J** Jitter, 5-16  
  Jitter (eye) softkey, 5-16  
  Jitter (measure eye) softkey, 6-39  
  jitter measurement, 9-6-8, 10-36  
    manual, 10-42

**L** Label (display) softkey, 11-34  
  Label Text (display) softkey, 11-36-37  
  leading edge event, 9-3  
  Level (eye) softkey, 5-6  
  Level (mask) softkey, 5-29  
  Level (trigger) softkey, 6-52, 10-62  
  level (utility) softkey, 11-88  
  lightwave adapters  
    cleaning, xxi  
  lightwave connector care, xvii  
  limit test, 1-13, 11-44  
    summary, 11-50  
  Limit Test Menu, 11-42-55  
  line  
    input, 1-16  
    on/off, 1-16  
    select, 1-16  
  Linear Offset (histogram) softkey, 10-43  
  Linear Scale (histogram) softkey, 10-43  
  load (disk) softkey, 11-6  
  Local (control) key, 2-6  
  Local Lockout command, 2-6  
  locating crossing points, 7-9  
  Location (display) softkey, 11-33  
  logic level, 5-10, 5-21, 5-23, 6-32  
  Log Offset (histogram) softkey, 10-43  
  Log Scale (histogram) softkey, 10-43  
  lower failure threshold, 11-47  
  Lower Limit (limit test) softkey, 11-47  
  lower threshold, 7-10  
    unit of measure, 10-10  
  Lower (threshold) softkey, 10-9

Luminosity (display) softkey, 11-41

- M** Magnify (FFT) softkey, 10-26
- magnify (math) softkey, 10-47
- Magnify Span (FFT) softkey, 10-26
- mainframe calibration, 4-4
- maintenance agreement, xii
- Main (time base) function, 6-48
- Main (time base) softkey, 10-57
- making a mask measurement, 5-31
- manual
  - record length, 10-6
  - threshold setting, 7-10
- Manual (acquisition) mode, 10-6
- manual (marker) softkey, 11-57
- manual measurement
  - jitter, 10-42
  - time interval, 9-5
- margin
  - hits, 5-35
  - of compliance, 5-34
  - value, 5-36
- Margin % (mask test) softkey, 6-18
- Margin % softkey, 5-34
- marker, 9-5
  - color, 11-56
  - hints, 11-63
  - lines, 5-10
  - menu overview, 11-56
  - position readout, 11-60
  - threshold setting, 10-11
  - to show top-base setting, 10-13
  - voltage measurement, 11-59
- Marker (define measure) key, 10-13
- Marker Menu, 11-56-63
- Marker Results display, 1-12
- mask
  - custom, 6-19
  - failure, 5-36
  - file format, 11-14
  - fixed voltage, 6-4
  - generating, 5-33
  - margins, 5-34, 6-17
  - setup and alignment, 5-49
  - standard, 5-26, 5-32, 6-4
  - test results, 6-25
  - user-defined, 6-5
  - violation, 5-42

Mask Align (mask test) softkey, 6-21  
Mask align softkey, 5-33  
mask and setup format, 11-21  
mask (disk) softkey, 11-13  
Mask Formats (disk) softkey, 11-21  
Mask margins softkey, 5-34  
mask measurement, 5-25-36  
    making of, 5-31  
    overview, 5-2, 5-25  
    setting up, 5-27  
    waveform conformance, 5-34  
mask only format, 11-21  
mask test, 1-13, 6-6, 10-37  
    features, 6-6  
    mode, 10-6  
    overview, 6-3  
Mask test key, 5-31  
Mask test menu, 6-3-29  
Mask to Wfirm (mask test) softkey, 6-22  
Math menu, 10-46-52  
    overview, 10-46  
maximum deviation, 9-5  
maximum/minimum voltage level measurement, 7-7  
max (math) softkey, 10-49  
mean crossing points, 5-15, 6-38  
mean deviation, 9-5, 10-18  
mean (histogram) softkey, 8-20  
mean, stddev (define measure) softkey, 10-20  
Meas Complete (define measure) softkey, 10-18  
Meas eye (eye) key, 5-9  
Meas Not Found (limit test) softkey, 11-46  
Measure Eye menu, 6-30-42  
measurement  
    algorithm, 5-5, 7-8, 10-8  
    automatic, 1-12, 8-3-22, 9-4, 10-14  
    average frequency, 8-3  
    capabilities, 1-3  
    channel-to-channel, 9-5  
    considerations, 7-20  
    increasing accuracy, 9-3-8, 9-19  
    parameters, 7-3  
    repeatability on the waveform, 10-4  
    result comparison, 11-42  
    statistics, 9-5  
    trends, 11-45  
    user-defined, 7-20  
    window, 5-10  
Measurement (define measure) softkey, 10-13  
Measurement (limit test) softkey, 11-44

measurement (marker) softkey, 11-61  
 Measurement Results display, 1-12  
 measuring time interval, 9-3  
 median (histogram) softkey, 8-21  
 Media (setup print) softkey, 11-73  
 memory bar display, 1-13  
 Memory (define measure) softkey, 10-11  
 Memory (limit test) softkey, 11-55  
 Memory (mask test) softkey, 6-29  
 memory protect, 1-17  
 Memory scaling (waveform) softkey, 11-95  
 menu overview, 1-7  
 message display, 12-2  
 $\mu \pm 1\sigma$  (histogram) softkey, 8-19  
 $\mu \pm 2\sigma$  (histogram) softkey, 8-19  
 $\mu \pm 3\sigma$  (histogram) softkey, 8-20  
 middle threshold, 7-10  
     unit of measure, 10-10  
 Middle (threshold) softkey, 10-9  
 minimum deviation, 9-5  
 minimum persistence, 6-7  
 min (math) softkey, 10-49  
 min, max (define measure) softkey, 10-21  
   – Width measurement, 7-18, 8-4  
   – width softkey, 8-6  
 MMS mainframe, 5-43  
 Mode (histogram) softkey, 10-40  
 Mode (limit test) softkey, 11-48  
 Mode (mask test) softkey, 6-23  
 Modify Label (display) softkey, 11-36  
 Move (mask test) softkey, 6-13  
 Move Polygon (mask test) softkey, 6-13  
 multiply (math) softkey, 10-48

**N** narrow pulse response, 9-16  
 noise measurement, 10-36  
 noise reduction, 5-40  
   of the waveform, 10-4  
 noise signals  
   internal, 6-33  
 non-lensed connector care, xx  
 non-symmetrical waveforms, 8-3  
 NRZ eye diagram, rise time, 10-16  
 NRZ eye pattern, 5-3

- O O/E calibration, 4-6
- O/E converter calibration, 4-16
- O/E user wavelength calibration, 4-10
- Off (define measure) softkey, 10-19
- Off (limit test) softkey, 11-51-55
- off (marker) softkey, 11-57
- Off (mask test) option, 6-26*ff*
- Off (mask test) softkey, 6-27, 6-29
- offset
  - calibration, 5-10
  - value, 10-45
- Offset (math) softkey, 10-51
- offset zero calibration, 4-13
- Operand (math) softkey, 10-50
- Operator (math) softkey, 10-47
- optical masks, 6-4, 6-9
- optical (mask) softkey, 5-33
- optical performance
  - testing, xxiii
- optical power measurement, 7-14
- optimum resolution and accuracy, 9-4
- Option 025, xxii
- optional accessories, 1-5
- options, 1-5
- output, CAL signal, 11-88
- Overshoot, 7-16
- overshoot measurement, 8-4
- Overshoot softkey, 8-7
- overview
  - of the front panel, 1-9
  - of the instrument, 1-3
  - of the rear panel, 1-15
  
- P packaging materials, xii
- Page Length (setup print) softkey, 11-73
- parallel printer port, 1-17
- parameter measurement, 7-3
- Pass (limit test) softkey, 11-46
- pattern generator, eyeline, 5-43
- peak (histogram) softkey, 8-21
- Peak number (freq domain) softkey, 8-17
- peak-to-peak jitter, 5-16
- performance
  - capabilities/characteristics, 3-2
- period measurement, 7-10, 8-3
  - timing, 7-17
- Period softkey, 8-8
- persistence, 6-7



- infinite, 11-26
  - variable, 11-25
- Persistence (display) softkey, 11-25
- pigtail connections, xxii
- pixel memory, 11-93
- pixel memory (disk) softkey, 11-12
- Pixel Memory (limit test) softkey, 11-54
- Pixel Memory (mask test) softkey, 6-27
- Pixel (waveform) softkey, 11-97
- pk-pk (histogram) softkey, 8-21
- Pk threshold (freq domain) softkey, 8-18
- plug-in
  - display box, 11-82
- plug-in module vertical calibration, 4-12
- Point (mask test) softkey, 6-12
- polarity, dc errors, 9-11
- polygon
  - creating, 6-14
  - editing, 6-16
- Polygon# (mask test) softkey, 6-10
- polygons, 6-5
- Position (eye) softkey, 5-7
- positioning the waveform, 5-5, 5-28
- +Position (marker) softkey, 11-60
- Position (mask) softkey, 5-30
- position setting, 1-12
- Position (time base) softkey, 6-46, 10-55
- power measurement, 7-14-16
- power statistics, 11-81
- PRBS pattern, 5-48
- presetting parameters, FFT, 10-35
- Preshoot, 7-16
- preshoot measurement, 8-4
- Preshoot softkey, 8-8
- Printer (limit test) softkey, 11-51, 11-54
- Printer (mask test) softkey, 6-26, 6-28
- Print format (setup print) softkey, 11-72
- printing problem report, 11-90
- Print problem report (utility) softkey, 11-90
- probe
  - capacitive loading, 9-18
  - choosing, 13-12
  - loading, 13-13
  - signal, 9-14
  - types, 13-18-20
- probe calibration, 4-16, 4-17
- problem report
  - form, 11-90
  - printing, 11-90

- Procedure to Define a Mask (mask test) softkey, 6-10
- processors, 13-10
- program operation (eyeline), 5-44
- propagation delay measurement, 9-3, 9-5
- pulse filter, 13-9
- pulse generator, 9-6
- pulse height measurement errors, 9-17
- pulse measurement thresholds, 10-9
- pulse parameters, 7-3
  - automatic measurement, 9-4
- pulse waveform
  - rise time, 10-16
- pulse width measurement, 8-4, 9-3
  - automatic, 9-4
  - errors, 9-18

**Q** Q-factor, 5-19

- Q-factor (eye) softkey, 5-20
- Q-factor (measure eye) softkey, 6-41
- q level, 7-4
- quantization level, 9-13

**R** Readout (marker) softkey, 11-61

- rear panel
  - eyeline connections, 5-43
  - features, 1-15
- Recall (setup) softkey, 11-66
- record length, 13-5
  - automatic, 10-6
  - manual, 10-6
- Record length (acquisition) softkey, 10-6
- reduction of noise, 5-40
- reference location, 1-12
- Reference (time base) softkey, 6-47, 10-56
- reference waveform, 6-5
  - tolerance, 6-8
- Refresh (disk) softkey, 11-5
- regulatory information, ii
- remote control, 2-6
- repair information, xi
- repetitive signal, 1-10
- resistive divider probes, 13-18
- resolution and accuracy, 9-4
- resolution improvement on the waveform, 10-4
- Resume Eyeline softkey, 5-45
- return loss
  - testing, xxiv
- rise time

- response, 9-15
- rise time measurement, 5-21, 7-4, 7-10, 8-4, 9-3
  - errors, 9-15
  - timing, 7-17
- Rise Time softkey, 8-8
- rising edge
  - determination, 7-11
  - measurement, 8-4
- RMS jitter, 5-16
- Row (display) softkey, 11-35, 11-37
- Run (control) key, 2-7
- Run . . . (mask test) softkey, 6-23
- Run Until (histogram) softkey, 10-45
- Run Until (limit test) softkey, 11-48
- Run Until Mode (histogram) softkey, 10-37

**S** safety information, iii-7

- sales and service offices, xii
- Samplers (utility) softkey, 11-88
- Samples (mask test) softkey, 6-24
- sampling
  - sequential, 13-3
  - Shannon's theorem, 13-4
- Saturation (display) softkey, 11-40
- saturation level, 6-6
- Save/recall (mask test) softkey, 6-17
- Save (setup) softkey, 11-65
- Save (waveform) softkey, 11-96
- Scale (eye) softkey, 5-7
- Scale Mask (mask test) softkey, 6-19
- Scale (mask) softkey, 5-29, 5-30
- Scale (math) softkey, 10-51
- Scale Mode (histogram) softkey, 10-45
- scale setting, 1-12
- Scale Source (histogram) softkey, 10-41
- Scale source (mask test) softkey, 6-19
- Scale (time base) softkey, 6-46, 10-55
- Scale Type (histogram) softkey, 10-43
- screen mode, 11-31
- Screen (setup print) softkey, 11-76
- Select Next Label (display) softkey, 11-37-38
- Self-test (utility) softkey, 11-88
- sequential delay generator, 13-10
- sequential sampling, 13-3
- service information, xi, xii, 12-2-6
- Service (utility) softkey, 11-90
- setting
  - the trigger, 5-6

- thresholds, 10-8
  - up your system, 5-4
- setup
  - print menu overview, 11-70
  - settings default, 11-66
  - time measurement, 9-3, 9-5
- Setup area of the front panel, 6-54
- Setup (disk) softkey, 11-12
- setup memory, 11-64
- Setup memory (setup) softkey, 11-65
- Setup Menu, 11-64-69
- Setup Print Menu, 11-70-77
- Setup Storage menu, 9-4
- Shannon's sampling theorem, 13-4
- shifted function keys, 1-7
- shipping materials, xii
- signal
  - display, 1-10
  - edge, 7-4
  - source, 9-6
- Signal type (define measure) softkey, 10-16
- sine-wave source, 9-6
- skew calibration, 4-16
- Slope (trigger) softkey, 6-52, 10-63
- softkey menu, 1-13
  - overview, 1-7
- software (eyeline) installation, 5-47
- Source (eye) softkey, 5-6
- Source (FFT) softkey, 10-23
- Source (freq domain) softkey, 8-17
- +Source (marker) softkey, 11-60
- Source (mask) softkey, 5-29
- Source (mask test) softkey, 6-8
- Source (trigger) softkey, 6-51, 10-61
- specifications, 3-2, 3-3-7
- standard
  - deviation, 9-5, 10-18
  - mask, 5-26, 5-32, 6-4
  - waveform definitions, 7-14-20, 8-4
- Standard (define measure) softkey, 10-12
- Standard Mask (mask test) softkey, 6-9
- Standard mask softkey, 5-33
- Start Edge (define measure) softkey, 10-14
- statistical database, 5-3
- statistics
  - measurement, 9-5
  - power, 11-81
  - viewing, 9-5
- Statistics (define measure) softkey, 10-18

- Statistics Results display, 1-12
- Statistics softkey, 9-5
- Status area display, 1-12
- std dev (histogram) softkey, 8-22
- Stop Edge (define measure) softkey, 10-14
- Stop/Single (control) key, 2-8
- Stop/Single key, 10-37
- store (disk) softkey, 11-8
- Store Screen (limit test) softkey, 11-54
- Store Screen (mask test) softkey, 6-27
- store summary
  - choices, 11-51
  - file names, 11-51
- Store Summary (limit test) softkey, 11-50
- Store Summary (mask test) softkey, 6-25
- Store Waveforms (limit test) softkey, 11-55
- Store wforms (mask test) softkey, 6-28
- subtract (math) softkey, 10-48
- summary file, 11-51
  - messages, 6-27
- supplied accessories, 1-5
- sweep
  - position, 6-46, 10-55
  - speed, 6-46, 10-55
- Sweep (trigger) softkey, 6-51, 10-60
- system
  - architecture, 13-8
  - bandwidth, 13-17
  - setup, 5-4
- System Configuration (utility) softkey, 11-80
- system firmware
  - updating, 11-84

**T** TDR/TDT (marker) softkey, 11-62

- temperature, 3-6
- test capabilities, 1-3
- Test (limit test) softkey, 11-44
- Test (mask test) softkey, 6-7
- test results failure summary, 11-50
- text verbose (disk) softkey, 11-15
- text verbose file format, 11-11
- text verbose format
  - definitions, 11-17
  - for a versus waveform, 11-15
- text Y file format, 11-11
- text Y values (disk) softkey, 11-19
- text Y values format example, 11-19
- threshold

- detection algorithm, 10-10
- level, 5-21, 5-23, 7-4
- level calculation, 7-10
- pulse measurement, 10-9
- setting, 10-8
- setting the unit of measure, 10-10
- timing measurement, 10-9
  - user-defined, 7-20
  - using markers, 10-11
  - vertical reference, 10-11
- Thresholds (define measure) softkey, 10-9, 10-11
- TIFF files, converting, 11-77
- time and date, 11-82
- time base, 5-7
  - jitter, 9-6
  - position adjustment, 5-49
- Time Base display, 1-12
- Time base (eye) key, 5-7
- Time base (mask) key, 5-30
- Time Base menu, 6-44-49, 9-6, 10-53-58
  - overview, 6-44, 10-53
- Time base (time base) softkey, 10-57
- Time Base (time base) softkey, 6-48
- Time base windowing (time base) softkey, 6-48, 10-57
- time/division scale, 9-4
- time interval, measuring, 9-3, 9-6, 9-9
- time location variance of crossing points, 6-39
- time units, 5-30
- Time (utility) softkey, 11-82
- timing diagram, 11-98
- timing measurement, 7-11, 7-17, 10-9
  - definitions, 7-14-20, 8-4
  - histogram, 10-36
- Tmax (general meas) softkey, 8-12
- Tmax measurement, 7-7
- Tmin (general meas) softkey, 8-12
- Tmin measurement, 7-7
- To File (disk) softkey, 11-22
- To memory (disk) softkey, 11-23
- To memory (waveform) softkey, 11-96
- Top-base (define measure) softkey, 10-11
- top-base values, markers, 10-13
- top level algorithm, 9-4
- top voltage value, 10-12
- top waveform measurement, 7-8
- total hits, 5-35
- trace averaging, 5-40
- trailing edge event, 9-3
- transition point determination, 7-11

- Trig Bandwidth softkey, 6-53, 10-63
- trigger, 5-39
  - amplitude, 1-10
  - basics, 6-50, 10-60
  - display, 1-10
  - event, 1-14
  - external, 1-10
  - generator, 13-10
  - input, 13-9
  - level, 5-6, 5-29
  - marker, 9-6
  - signal, 1-10, 5-29
  - status, 6-50, 10-60
  - threshold, 1-14
- triggered light, 1-14
- Triggered (trigger) softkey, 6-51, 10-61
- Trigger (eye) key, 5-6
- Trigger gate, 1-17
- Trigger (mask) key, 5-29
- Trigger menu, 6-50-54, 9-6, 10-59-64
  - overview, 6-50, 10-59
- trigger modes, 13-22-32
- trigger specifications, 3-4, 3-5
- troubleshooting, 12-2
- Turn Off All Store Wforms (mask test) softkey, 6-29
- Tvolt measurement, 7-7
- two channel measurement, 9-3
- Type (disk) softkey, 11-11
- Type (display) softkey, 11-31

**U**

- $\Delta$  time measurement, 8-3
- $\Delta$ time measurement, 7-19
- $\Delta$ time softkey, 8-5
- $\Delta X$  (mask test) softkey, 6-8, 6-20
- $\Delta Y$  (mask test) softkey, 6-8
- Undo Autoscale softkey, 1-10
- Units (eye) softkey, 5-7
- Units (mask) softkey, 5-30
- Units (mask test) softkey, 6-8
- Units (time base) softkey, 6-45, 10-54
- Update System Firmware (utility) softkey, 11-84
- Upper (define measure) softkey, 10-11
- upper failure threshold, 11-47
- Upper Limit (limit test) softkey, 11-47
- upper threshold, 7-10
  - unit of measure, 10-10
- Upper (threshold) softkey, 10-9
- user calibrations, 4-8

- user-defined
  - masks, 6-5
  - measurements, 7-20
  - threshold, 7-20
  - $\Delta$ time measurement, 7-19
- User defined (define measure) softkey, 10-11
- User Defined (define measure) softkey, 10-10, 10-13
- user interface hardware, 13-11
- Utility menu, 11-78-92

**V** valid trigger event, 1-14

- Vamp, 7-15
  - measurement, 7-9
- Vamp softkey, 8-9
- V amptd (define measure) softkey, 10-13
- variable (display) softkey, 11-25
- variable persistence, 5-51, 11-25
- Vavg, 7-15
  - cycle, 7-11, 7-15
- Vavg (general meas) softkey, 8-12
- Vbase, 7-14
  - measurement, 7-9
- Vbase softkey, 8-9
- verifying waveform conformance to the mask, 5-34
- versus (math) softkey, 10-48
- vertical
  - axis, 10-45
  - channel errors, 9-9
  - dc errors, 9-9
  - display, 1-10, 10-40
  - histogram, 6-32, 6-36, 10-36
  - marker, 10-42, 11-59
  - quantization, 9-13
  - reference thresholds, 10-11
  - resolution, 11-30
  - scale, 5-7, 5-29
  - scaling factors, 11-55
  - tolerance of reference waveform, 6-8
- Vertical (math) softkey, 10-52
- vibration, 3-6
- video RAM, 13-11
- viewing statistics, 9-5
- View (time base) softkey, 6-48, 10-57
- visual reference point, 11-56
- Vlower (general meas) softkey, 8-13
- Vmax, 7-14
- Vmiddle (general meas) softkey, 8-13
- Vmin, 7-14



- measurement, 7-7
- voltage level, 7-4
- voltage measurement, 7-11, 7-14-16
  - definitions, 7-14-20, 8-4
  - histogram, 10-36
  - transition time, 9-3
  - with markers, 11-59
- voltage probe calibration, 4-17
- Vp-p, 7-14
  - measurement, 7-4, 7-7
- Vpp softkey, 8-9
- Vrms cycle, 7-11
- Vrms softkey, 8-10
- Vtop, 7-14
  - measurement, 7-9
- Vtop softkey, 8-10
- Vupper (define measure) softkey, 10-11
- Vupper (general meas) softkey, 8-13

**W** warranty information, xi

- waveform
  - annotation, 11-34
  - conformance, 5-34
  - data display, 1-12, 2-7
  - file format, 11-14
  - histogram, 10-6
  - jitter measurement, 10-36
  - marker display, 1-12
  - markers, 11-59
  - measurement, 9-19
  - measurement process, 7-4-13
  - measurement repeatability, 10-4
  - memory, 6-29, 11-23
  - menu overview, 11-93
  - noise measurement, 10-36
  - noise reduction, 10-4
  - non-symmetrical, 8-3
  - period measurement, 7-13
  - position, 5-5, 5-28
  - record display, 1-13
  - resolution improvement, 10-4
  - tolerance, 6-8
- Waveform (disk) softkey, 11-11
- Waveform (display) softkey, 11-33
- Waveform (histogram) softkey, 10-40
- waveform memory, 11-55
- Waveform menu, 11-93-98
- Waveforms (limit test) softkey, 11-48

Waveforms (mask test) softkey, 6-24  
waveform (waveform) softkey, 11-94  
+width softkey, 8-6  
+Width timing measurement, 7-18  
window  
  boundries, 6-32, 10-17  
  scale, 10-41  
Window (FFT) softkey, 10-24  
windowing the signal, 7-20, 8-3  
Window Position (time base) softkey, 6-49, 10-58  
Window Scale (time base) function, 6-48  
Window Scale (time base) softkey, 10-57  
Window (time base) function, 6-48  
Window (time base) softkey, 10-57

**X** X1 marker scaling, 6-19  
X1 Position (marker) softkey, 11-58  
X1 Position (mask test) softkey, 6-19  
X1,Y1 Source (marker) softkey, 11-58  
X2 Position (marker) softkey, 11-58  
X2,Y2 Source (marker) softkey, 11-58  
X and Y Position (histogram) softkey, 10-42  
X marker, 5-10  
X (mask test) softkey, 6-12  
X Position (marker) softkey, 11-60  
X Source (marker) softkey, 11-60

**Y** Y1 marker scaling, 6-19  
Y1 Position (marker) softkey, 11-59  
Y2 Position (marker) softkey, 11-59  
Y marker, 5-10  
Y (mask test) softkey, 6-12  
Y-Offset (FFT) softkey, 10-27  
Y-Scale (FFT) softkey, 10-27