



**Agilent 34970A/34972A  
Data Acquisition /  
Switch Unit**

**User's Guide**



**Agilent Technologies**

# Notices

© Agilent Technologies, Inc. 2009-2012

No part of this manual may be reproduced in any form or by any means (including electronic storage and retrieval or translation into a foreign language) without prior agreement and written consent from Agilent Technologies, Inc. as governed by United States and international copyright laws.

## Manual Part Number

34972-90001

Third Edition, May 2012

Printed in Malaysia

Agilent Technologies, Inc.  
900 S. Taft Ave.  
Loveland, CO 80537 USA

Adobe, the Adobe Logo, Acrobat and the Acrobat Logo are trademarks of Adobe Systems Incorporated.

Microsoft is either a registered trademark or a trademark of Microsoft Corporation in the United States and/or other countries.

Windows and MS Windows are U.S. registered trademarks of Microsoft Corporation.

## Software Updates/Licenses

Periodically, Agilent releases software updates to fix known defects and incorporate product enhancements. To search for software updates and the latest documentation for your product, go to the product page at:

[www.agilent.com/find/34970A](http://www.agilent.com/find/34970A)  
[www.agilent.com/find/34972A](http://www.agilent.com/find/34972A)

A portion of the software in this product is licensed under terms of the General Public License. A copy of the license and source code can be found at:

[www.agilent.com/find/GPLV2](http://www.agilent.com/find/GPLV2)

This product utilizes Microsoft Windows CE. Agilent highly recommends that all Windows-based computers connected to Windows CE instruments utilize current anti-virus software. For more information, go to the product page at:

[www.agilent.com/find/34970A](http://www.agilent.com/find/34970A)  
[www.agilent.com/find/34972A](http://www.agilent.com/find/34972A)

## Declaration of Conformity

Declarations of Conformity for this product and for other Agilent products may be downloaded from the Web. Go to <http://regulations.corporate.agilent.com> and click on "Declarations of Conformity." You can then search by product number to find the latest Declaration of Conformity.

## Warranty

**The material contained in this document is provided "as is," and is subject to being changed, without notice, in future editions. Further, to the maximum extent permitted by applicable law, Agilent disclaims all warranties, either express or implied, with regard to this manual and any information contained herein, including but not limited to the implied warranties of merchantability and fitness for a particular purpose. Agilent shall not be liable for errors or for incidental or consequential damages in connection with the furnishing, use, or performance of this document or of any information contained herein. Should Agilent and the user have a separate written agreement with warranty terms covering the material in this document that conflict with these terms, the warranty terms in the separate agreement shall control.**

## Technology Licenses

The hardware and/or software described in this document are furnished under a license and may be used or copied only in accordance with the terms of such license.

## Restricted Rights Legend

If software is for use in the performance of a U.S. Government prime contract or subcontract, Software is delivered and licensed as "Commercial computer software" as defined in DFAR 252.227-7014 (June 1995), or as a "commercial item" as defined in FAR 2.101(a) or as "Restricted computer software" as defined in FAR 52.227-19 (June 1987) or any equivalent agency regulation or contract clause. Use, duplication or disclosure of Software is subject to Agilent Technologies' standard commercial license terms, and non-DOD Departments and Agencies of the U.S. Government will receive no greater than Restricted Rights as defined in FAR 52.227-19(c)(1-2) (June 1987). U.S. Government users will receive no greater than Limited Rights as defined in FAR 52.227-14 (June 1987) or DFAR 252.227-7015 (b)(2) (November 1995), as applicable in any technical data.

---

## Safety Notices

### CAUTION

A **CAUTION** notice denotes a hazard. It calls attention to an operating procedure, practice, or the like that, if not correctly performed or adhered to, could result in damage to the product or loss of important data. Do not proceed beyond a **CAUTION** notice until the indicated conditions are fully understood and met.

### WARNING

A **WARNING** notice denotes a hazard. It calls attention to an operating procedure, practice, or the like that, if not correctly performed or adhered to, could result in personal injury or death. Do not proceed beyond a **WARNING** notice until the indicated conditions are fully understood and met.

## Additional Safety Notices

The following general safety precautions must be observed during all phases of operation of this instrument. Failure to comply with these precautions or with specific warnings or instructions elsewhere in this manual violates safety standards of design, manufacture, and intended use of the instrument. Agilent Technologies assumes no liability of the customer's failure to comply with the requirements.

### General

Do not use this product in any manner not specified by the manufacturer. The protective features of this product may be impaired if it is used in a manner not specified in the operation instructions.

### Before Applying Power

Verify that all safety precautions are taken. Make all connections to the unit before applying power and select the appropriate power line voltage on the fuse module.

### Ground the Instrument

This product is provided with protective earth terminals. To minimize shock hazard, the instrument must be connected to the ac power mains through a grounded power cable, with the ground wire firmly connected to an electrical ground (safety ground) at the power outlet. Any interruption of the protective (grounding) conductor or disconnection of the protective earth terminal will cause a potential shock hazard that could result in personal injury.

### Do Not Operate in an Explosive Atmosphere

Do not operate the instrument in the presence of flammable gases or fumes.

### Do Not Remove the Instrument Cover

Only qualified, service-trained personnel who are aware of the hazards involved should remove the instrument covers. Always disconnect the power cable and

any external circuits before removing the instrument cover.

### Do Not Modify the Instrument

Do not install substitute parts or perform any unauthorized modification to the product. Return the product to an Agilent Sales and Service Office for service and repair to ensure that safety features are maintained.

### In Case of Damage

Instruments that appear damaged or defective should be made inoperative and secured against unintended operation until they can be repaired by qualified service personnel.

## Safety Symbols

### CAUTION

Unless otherwise noted in the specifications, this instrument or system is intended for indoor use in an installation category II, pollution degree 2 environment per IEC 61010-1 and 664 respectively. It is designed to operate at a maximum relative humidity of 20% to 80% at 40 °C or less (non-condensing). This instrument or system is designed to operate at altitudes up to 2000 meters, and at temperatures between 0 °C and 55 °C.

### Technical Support

If you have questions about your shipment, or if you need information about warranty, service, or technical support, contact Agilent Technologies:

In the United States: (800) 829-4444

In Europe: 31 20 547 2111

In Japan: 0120-421-345

Or go to

[www.agilent.com/find/assist](http://www.agilent.com/find/assist)

for information on contacting Agilent in your country of specific location. You can also contact your Agilent Technologies Representative.

 Alternating current

 Frame or chassis terminal

 Standby supply. Unit is not completely disconnected from AC mains when switch is off.

 Caution, risk of electric shock

 Caution, refer to accompanying documents

 Earth ground terminal

CAT I IEC Measurement

 The CE mark is a registered trademark of the European

 The CSA mark is a registered trademark of the CSA-International.

 The C-tick mark is a registered trademark of the Spectrum Management Agency of Australia. This signifies compliance with the Australian EMC Framework regulations under the terms of the Radio Communications

N10149

 Contains one or more of the 6 hazardous substances above the maximum concentration value (MCV), 40 Year EPUP.

ISM1- This text indicates that the instrument is an Industrial Scientific and Medical Group 1 Class A product (CISPER 11, Clause 4).

This text indicates product compliance with the Canadian Interference-Causing Equipment Standard (ICES-001).

[www.valuetronics.com](http://www.valuetronics.com)

NMB  
-001

---

**Note:** *Unless otherwise indicated, this manual applies to all serial numbers.*

The Agilent Technologies 34970A/34972A combines precision measurement capability with flexible signal connections for your production and development test systems. Three module slots are built into the rear of the instrument to accept any combination of data acquisition or switching modules. The combination of data logging and data acquisition features makes this instrument a versatile solution for your testing requirements now and in the future.

### **Convenient Data Logging Features**

- Direct measurement of thermocouples, RTDs, thermistors, DC voltage, AC voltage, resistance, DC current, AC current, frequency, and period
- Interval scanning with storage of up to 50,000 time-stamped readings
- Independent channel configuration with function, Mx+B scaling, and alarm limits available on a per-channel basis
- Intuitive user interface with knob for quick channel selection, menu navigation, and data entry from the front panel
- Portable, ruggedized case with non-skid feet
- *BenchLink Data Logger 3 Software* for Microsoft® Windows® included

### **Flexible Data Acquisition/Switching Features**

- 6½-digit multimeter accuracy, stability, and noise rejection
- Up to 60 channels per instrument (120 single-ended channels)
- Reading rates up to 500 readings per second on a single channel and scan rates up to 250 channels per second
- Choice of multiplexing, matrix, general-purpose Form C switching, RF switching, digital I/O, totalize, and 16-bit analog output functions
- GPIB (IEEE-488) interface and RS-232 interface are standard on the 34970A. Local Area Network (LAN) and Universal Serial Bus (USB) are standard on the 34972A.
- SCPI (*Standard Commands for Programmable Instruments*) compatibility

---

# Agilent 34970A/34972A Data Acquisition/Switch Unit

# The Front Panel at a Glance

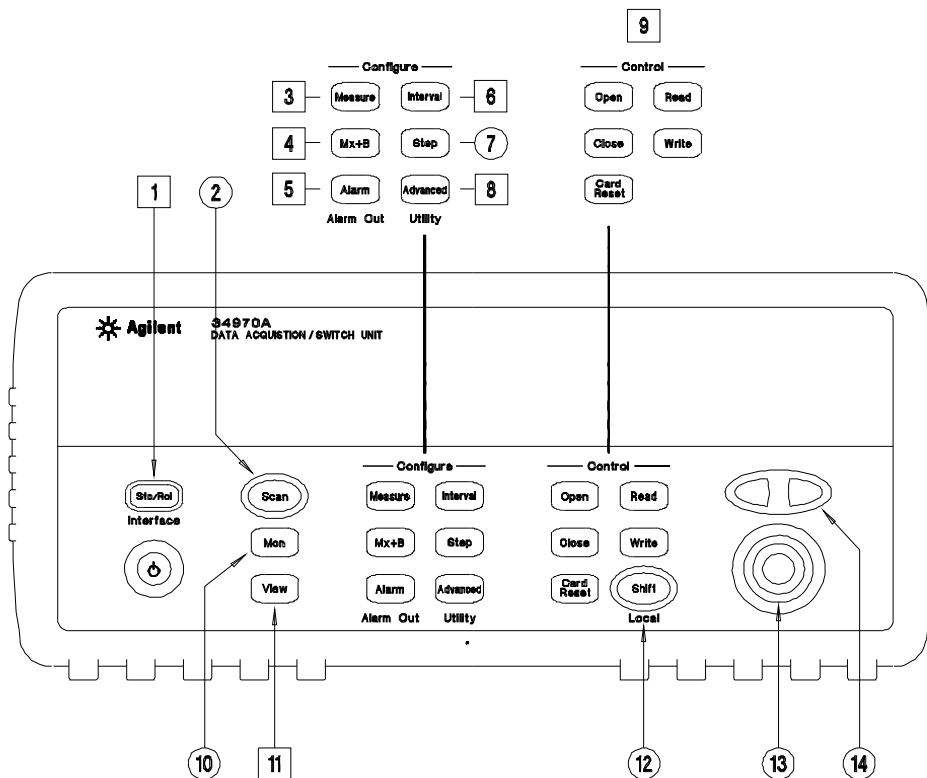

Denotes a menu key. See the next page for details on menu operation.

- |   |   |
|---|---|
| 1 State Storage / Remote Interface Menus  | 8 Advanced Measurement / Utility Menus    |
| 2 Scan Start / Stop Key                   | 9 Low-Level Module Control Keys           |
| 3 Measurement Configuration Menu          | 10 Single-Channel Monitor On / Off Key    |
| 4 Scaling Configuration Menu              | 11 View Scanned Data, Alarms, Errors Menu |
| 5 Alarm / Alarm Output Configuration Menu | 12 Shift / Local Key                      |
| 6 Scan-to-Scan Interval Menu              | 13 Knob                                   |
| 7 Scan List Single Step / Read Key        | 14 Navigation Arrow Keys                  |

# The Front-Panel Menu at a Glance

Several of the front-panel keys guide you through menus to configure various parameters of the instrument (see previous page). The following steps demonstrate the menu structure using the **Sto/Rcl** key.

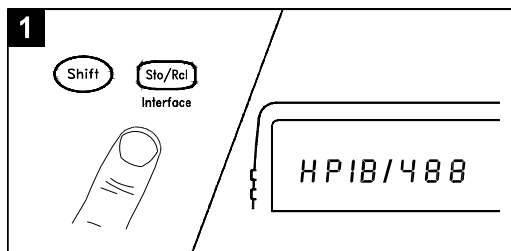

1. Press the menu key. You are automatically guided to the first level of the menu. Rotate the knob to view the other choices on the first level of the menu.

*The menu will automatically time out after about 20 seconds of inactivity. You will be returned to the operation in progress prior to entering the menu.*

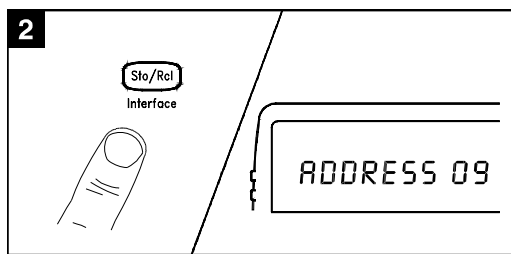

2. Press the *same* menu key again to move to the next item of the menu. Typically, this is where you choose parameter values for the selected operation.

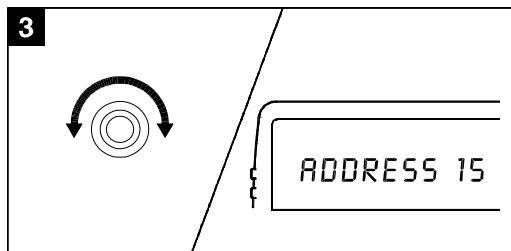

3. Rotate the knob to view the choices on this level of the menu. When you reach the end of the list, rotate the knob in the opposite direction to view all of the other choices.

*The current selection is highlighted for emphasis. All other choices are dimmed.*

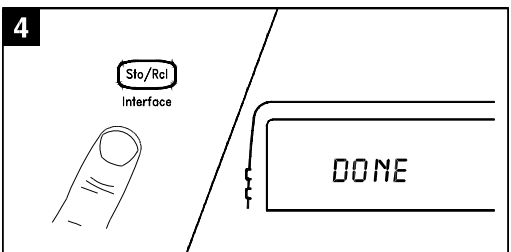



4. Press the *same* menu key again to accept the change and exit the menu. A brief confirmation message is displayed.

**Tip:** To review the current configuration of a specific menu, press the menu key several times. A message **NO CHANGES** is displayed when you exit the menu.

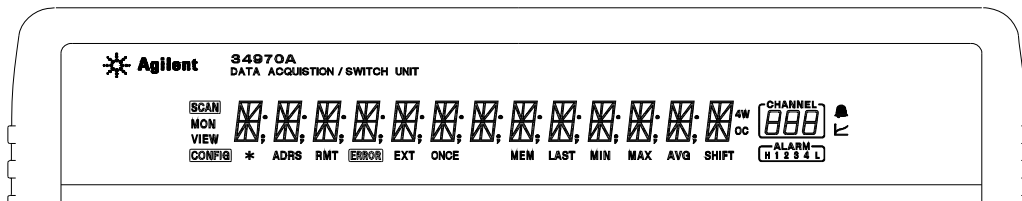
# Display Annunciators



<b>SCAN</b>	Scan is in progress or enabled. <i>Press and hold <b>Scan</b> again to turn off.</i>
<b>MON</b>	Monitor mode is enabled. <i>Press <b>Mon</b> again to turn off.</i>
<b>VIEW</b>	Scanned readings, alarms, errors, or relay cycles are being viewed.
<b>CONFIG</b>	Channel configuration is in progress on displayed channel.
<b>×</b>	Measurement is in progress.
<b>ADRS</b>	Instrument is addressed to listen or talk over the remote interface.
<b>RMT</b>	Instrument is in remote mode (remote interface).
<b>ERROR</b>	Hardware or remote interface errors are detected. <i>Press <b>View</b> to read errors.</i>
<b>EXT</b>	Instrument is configured for an external scan interval.
<b>ONCE</b>	Scan Once mode is enabled. <i>Press <b>Scan</b> to initiate and hold key to disable.</i>
<b>MEM (34970A)</b>	Reading memory overflow; new readings will overwrite the oldest readings.
<b>MEM (34972A)</b>	A USB drive is connected to the instrument (annunciator on), or data is being written to or read from the USB drive (annunciator flashing).
<b>AUTO (34972A)</b>	USB logging is active.
<b>LAST</b>	Viewed data is the <i>last</i> reading stored during most recent scan.
<b>MIN</b>	Viewed data is the <i>minimum</i> reading stored during most recent scan.
<b>MAX</b>	Viewed data is the <i>maximum</i> reading stored during most recent scan.
<b>SHIFT</b>	<b>Shift</b> has been pressed. <i>Press <b>Shift</b> again to turn off.</i>
<b>4W</b>	4-wire function is in use on displayed channel.
<b>OC</b>	Offset compensation is enabled on displayed channel.
	Alarms are enabled on displayed channel.
	Mx+B scaling is enabled on displayed channel.
	HI or LO alarm condition has occurred on indicated alarms.

To review the display annunciators, hold down the **Shift** key as you turn on the instrument.



# The 34970A Rear Panel at a Glance

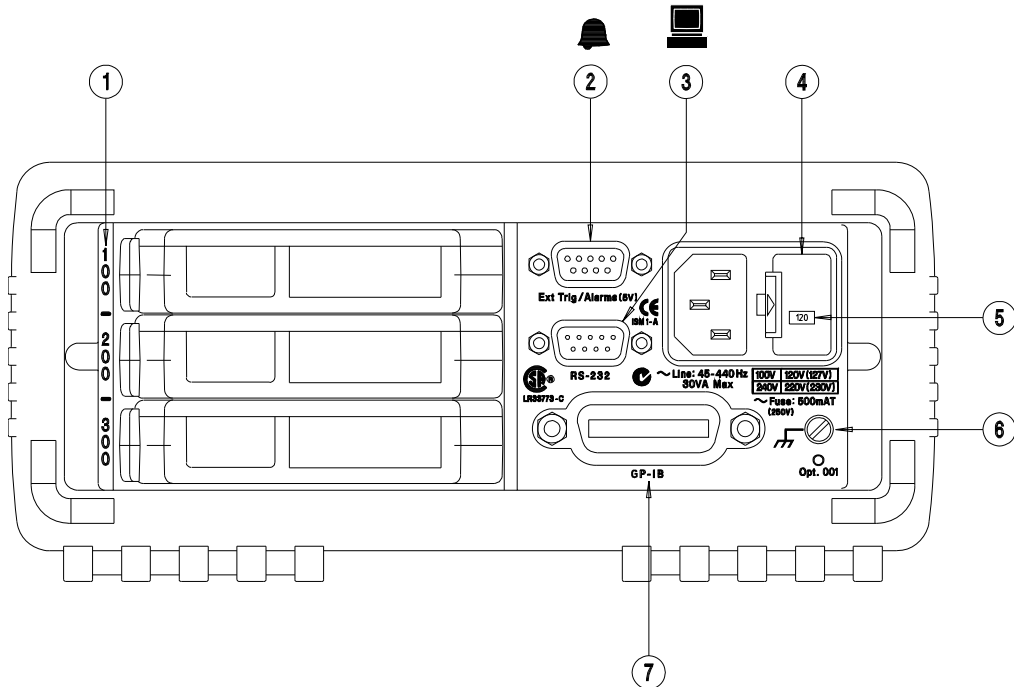

- 1 Slot Identifier (100,200, 300)
- 2 Ext Trig Input / Alarm Outputs / Channel Advance Input / Channel Closed Output (for pinouts, see pages 99 and 145)
- 3 RS-232 Interface Connector
- 4 Power-Line Fuse-Holder Assembly
- 5 Power-Line Voltage Setting
- 6 Chassis Ground Screw
- 7 GPIB (IEEE-488) Interface Connector

## Use the Menu to:

- Select the GPIB or RS-232 interface (see chapter 2).
- Set the GPIB address (see chapter 2).
- Set the RS-232 baud rate, parity, and flow control mode (see chapter 2).

## WARNING

*For protection from electrical shock, the power cord ground must not be defeated. If only a two-contact electrical outlet is available, connect the instrument's chassis ground screw (see above) to a good earth ground.*

# The 34972A Rear Panel at a Glance

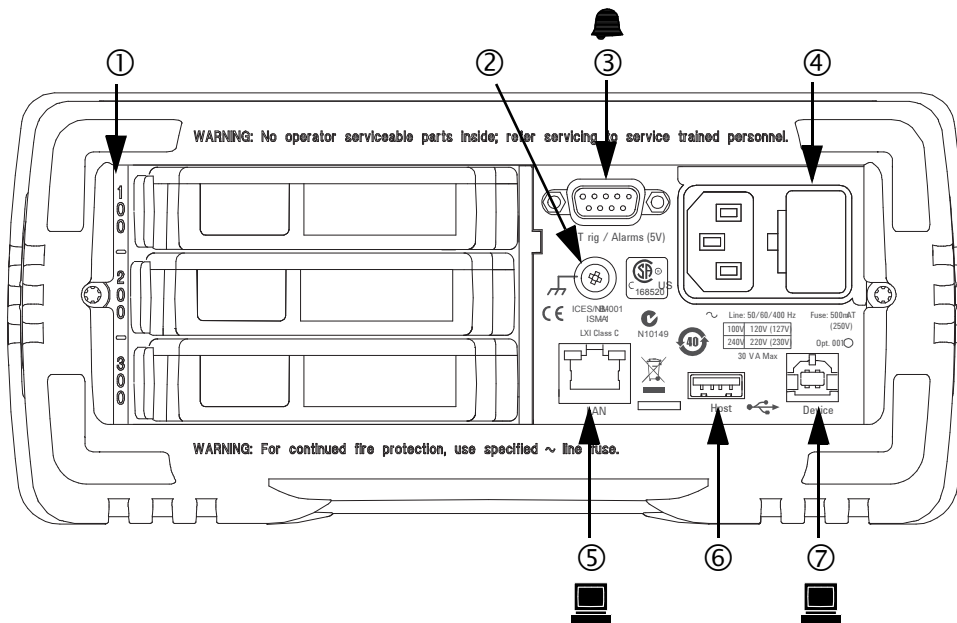

- |  |                                   |
|--|-----------------------------------|
| 1 Slot Identifier (100, 200, 300)  | 4 Power-Line Fuse-Holder Assembly |
| 2 Chassis Ground Screw   | 5 LAN Connector                   |
| 3 Ext Trig Input / Alarm Outputs / Channel Advance Input / Channel Closed Output (for pinouts, see pages 99 and 145) | 6 USB Drive Connector             |
|  | 7 USB Interface Connector         |

## Use the Menu to:

- Select and configure the LAN and USB interfaces (see chapter 2).

## WARNING

*For protection from electrical shock, the power cord ground must not be defeated. If only a two-contact electrical outlet is available, connect the instrument's chassis ground screw (see above) to a good earth ground.*

---

# BenchLink Data Logger 3 at a Glance

The *Agilent BenchLink Data Logger 3* software provides a convenient way to collect and analyze your data. The software uses a familiar spreadsheet environment, streamlining your data gathering needs. Simply identify the measurements you want to acquire, initiate the process, and see the data displayed on the computer screen. Use one of the many options to analyze and display your data—strip charts, histograms with statistical analysis, bar and scatter charts, individual channel results, and more.

A sample of the BenchLink Data Logger 3 features include:

- Tab based user interface, simple menu structure.
- A data manager that manages all configurations and data logs; simplifies opening, renaming, deleting, and editing; easy access to data export.
- A data log name template.
- Automatic data export with preconfigured preferences; control of the decimal character and field separator; control of the export contents.
- Graph configurations saved and restored automatically the next time Data Logger 3 is opened.
- Graph preferences to allow easy control of graph look and feel.
- Split graphs for easy viewing of independent measurements.
- Import Data Logger I and Data Logger II configurations.
- Configure up to four 34970A/34972As for simultaneous scanning.

**Note:**



*To install the software, refer to “Installing BenchLink Data Logger 3 Software” on page 25.*



*To learn more about the software and its capabilities, refer to the On-Line Help System for BenchLink Data Logger 3.*

*For increased capabilities, purchase the optional **Agilent BenchLink Data Logger Pro** software. This software provides advanced data logging and decision making with no programming required.*

---

## The Plug-In Modules at a Glance

*For complete specifications on each plug-in modules, refer to the module sections in chapter 8.*

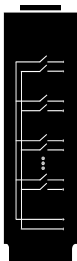

### **34901A 20-Channel Armature Multiplexer**

- 20 channels of 300 V switching
- Two channels for DC or AC current measurements (100 nA to 1A)
- Built-in thermocouple reference junction
- Switching speed of up to 60 channels per second
- Connects to the internal multimeter
- *For detailed information and a module diagram, see page 201.*

Each of the 20 channels switches both HI and LO inputs, thus providing fully isolated inputs to the internal multimeter. The module is divided into two banks of 10 two-wire channels each. When making four-wire resistance measurements, channels from *Bank A* are automatically paired with channels from *Bank B*. Two additional fused channels are included on the module (22 channels total) for making calibrated DC or AC current measurements with the internal multimeter (external shunt resistors are not required). You can close multiple channels on this module *only* if you have not configured any channels to be part of the scan list. Otherwise, all channels on the module are break-before-make.

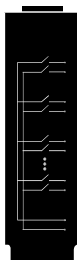

### **34902A 16-Channel Reed Multiplexer**

- 16 channels of 300 V switching
- Built-in thermocouple reference junction
- Switching speed of up to 250 channels per second
- Connects to the internal multimeter
- *For detailed information and a module diagram, see page 203.*

Use this module for high-speed scanning and high-throughput automated test applications. Each of the 16 channels switches both HI and LO inputs, thus providing fully isolated inputs to the internal multimeter. The module is divided into two banks of eight two-wire channels each. When making four-wire resistance measurements, channels from *Bank A* are automatically paired with channels from *Bank B*. You can close multiple channels on this module *only* if you have not configured any channels to be part of the scan list. Otherwise, all channels on the module are break-before-make.

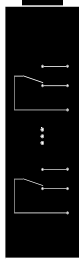

### 34903A 20-Channel Actuator / General-Purpose Switch

- 300 V, 1 A actuation and switching
- SPDT (Form C) latching relays
- Breadboard area for custom circuits
- *For detailed information and a module diagram, see page 205.*

Use this module for those applications that require high-integrity contacts or quality connections of non-multiplexed signals. This module can switch 300 V, 1 A (50 W maximum switch power) to your device under test or to actuate external devices. Screw terminals on the module provide access to the Normally-Open, Normally-Closed, and Common contacts for each of the 20 switches. A breadboard area is provided near the screw terminals to implement custom circuitry, such as simple filters, snubbers, or voltage dividers.

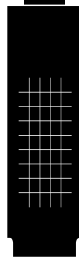

### 34904A 4x8 Two-Wire Matrix Switch

- 32 two-wire crosspoints
- Any combination of inputs and outputs can be connected at a time
- 300 V, 1 A switching
- *For detailed information and a module diagram, see page 207.*

Use this module to connect multiple instruments to multiple points on your device under test at the same time. You can connect rows and columns between multiple modules to build larger matrices such as 8x8 and 4x16, with up to 96 crosspoints in a single mainframe.

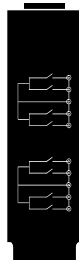

### 34905/6A Dual 4-Channel RF Multiplexers

- 34905A (50Ω) / 34906A (75Ω)
- 2 GHz bandwidth with on-board SMB connections
- 1 GHz bandwidth with SMB-to-BNC adapter cables provided
- *For detailed information and a module diagram, see page 209.*

These modules offer wideband switching capabilities for high frequency and pulsed signals. Each module is organized in two independent banks of 4-to-1 multiplexers. Both modules offer low crosstalk and excellent insertion loss performance. To create larger RF multiplexers, you can cascade multiple banks together. Only one channel in each bank may be closed at a time.



### 34907A Multifunction Module

- Two 8-bit Digital Input/Output ports, 400 mA sink, 42 V open collector
- 100 kHz Totalize input with 1 V<sub>pp</sub> sensitivity
- Two 16-bit, ±12 V Calibrated Analog Outputs
- *For detailed information and module block diagrams, see page 211.*

Use this module to sense status and control external devices such as solenoids, power relays, and microwave switches. For greater flexibility, you can read digital inputs and the count on the totalizer during a scan.



### 34908A 40-Channel Single-Ended Multiplexer

- 40 channels of 300 V single-ended (common LO) switching
- Built-in thermocouple reference junction
- Switching speed of up to 60 channels per second
- Connects to the internal multimeter
- *For detailed information and a module diagram, see page 213.*

Use this module for high-density switching applications which require single-wire inputs with a common LO. All relays are break-before-make to ensure that only one relay is connected at any time.

---

## In This Book

**Quick Start** Chapter 1 helps you get familiar with a few of the instrument's front-panel features. This chapter also shows how to install the *BenchLink Data Logger 3* software.

**Front-Panel Overview** Chapter 2 introduces you to the front-panel menus and describes some of the instrument's menu features.

**System Overview** Chapter 3 gives an overview of a data acquisition system and describes how parts of a system work together.

**Features and Functions** Chapter 4 gives a detailed description of the instrument's capabilities and operation. You will find this chapter useful whether you are operating the instrument from the front panel or over the remote interface.

**Error Messages** Chapter 5 lists the error messages that may appear as you are working with the instrument. Each listing contains enough information to help you diagnose and solve the problem.

**Application Programs** Chapter 6 contains several remote interface program examples to help you develop programs for your application.

**Tutorial** Chapter 7 discusses measurement considerations and techniques to help you obtain the best accuracies and reduce sources of measurement noise.

**Specifications** Chapter 8 lists the technical specifications for the mainframe and plug-in modules.



*If you have questions relating to the operation of the 34970A/34972A, call 1-800-452-4844 in the United States, or contact your nearest Agilent Technologies Sales Office.*

*If your 34970A/34972A fails within one year of original purchase, Agilent will replace it free of charge. Call 1-800-829-4444 and select "Option 3" followed by "Option 1".*





---

# Contents

## **Chapter 1 Quick Start**

To Prepare the Instrument for Use	23
BenchLink Data Logger Software	25
To Connect Wiring to a Module	27
To Set the Time and Date	29
To Configure a Channel for Scanning	30
To Copy a Channel Configuration	32
To Close a Channel	33
If the Instrument Does Not Turn On	34
To Adjust the Carrying Handle	36
To Rack Mount the Instrument	37

## **Chapter 2 Front-Panel Overview**

Front-Panel Menu Reference	41
To Monitor a Single Channel	44
To Set a Scan Interval	45
To Apply Mx+B Scaling to Measurements	46
To Configure Alarm Limits	47
To Read a Digital Input Port	49
To Write to a Digital Output Port	50
To Read the Totalizer Count	51
To Output a DC Voltage	52
To Configure the Remote Interface - 34970A	53
To Configure the Remote Interface - 34972A	55
To Store the Instrument State	57

## **Chapter 3 System Overview**

Data Acquisition System Overview	60
Signal Routing and Switching	70
Measurement Input	74
Control Output	83

## Chapter 4 Features and Functions

SCPI Language Conventions	89
Scanning	90
Scanning with External Instruments	111
General Measurement Configuration	115
Temperature Measurement Configuration	123
Voltage Measurement Configuration	130
Resistance Measurement Configuration	132
Current Measurement Configuration	133
Frequency Measurement Configuration	135
Mx+B Scaling	136
Alarm Limits	139
Digital Input Operations	151
Totalizer Operations	153
Digital Output Operations	157
DAC Output Operations	159
System-Related Operations	160
Single-Channel Monitoring	171
Mass Memory (USB) Subsystem - 34972A	174
USB Drive Front Panel - 34972A	181
Remote Interface Configuration - 34970A	183
Remote Interface Configuration - 34972A	188
Calibration Overview	192
Factory Reset State	197
Instrument Preset State	198
Multiplexer Module Default Settings	199
Module Overview	200
34901A 20-Channel Multiplexer	201
34902A 16-Channel Multiplexer	203
34903A 20-Channel Actuator	205
34904A 4x8 Matrix Switch	207
34905A/6A Dual 4-Channel RF Multiplexers	209
34907A Multifunction Module	211
34908A 40-Channel Single-Ended Multiplexer	213

---

# Contents

## **Chapter 5 Error Messages**

Execution Errors	219
Instrument Errors	224
Self-Test Errors	235
Calibration Errors	236
Plug-In Module Errors	239

## **Chapter 6 Application Programs**

Example Programs for Excel 7.0	243
Example Programs for C and C++	250

## **Chapter 7 Tutorial**

System Cabling and Connections	257
Measurement Fundamentals	265
Low-Level Signal Multiplexing and Switching	300
Actuators and General-Purpose Switching	306
Matrix Switching	310
RF Signal Multiplexing	312
Multifunction Module	314
Relay Life and Preventive Maintenance	321

## **Chapter 8 Specifications**

DC, Resistance, and Temperature Accuracy Specifications	326
DC Measurement and Operating Characteristics	327
AC Accuracy Specifications	328
AC Measurement and Operating Characteristics	329
System Characteristics	330
System Speed Specifications [1]	331
System Speed Specifications	332
Module Specifications	333
Module Specifications	334
Typical AC Performance Graphs	335
Module Specifications	336
Product and Module Dimensions	337
To Calculate Total Measurement Error	338
Interpreting Internal DMM Specifications	340
Configuring for Highest Accuracy Measurements	343





---

# Quick Start

---

# Quick Start

One of the first things to do with your instrument is to become acquainted with the front panel. We have written the exercises in this chapter to prepare the instrument for use and help you get familiar with some of its front-panel operations.

The front panel has several groups of keys to select various functions and operations. A few keys have a *shifted* function printed in blue below the key. To perform a shifted function, press  (the **SHIFT** annunciator will turn on). Then, press the key that has the desired label below it. For example, to select the Utility Menu, press  .

If you accidentally press , just press it again to turn off the **SHIFT** annunciator.

This chapter is divided into the following sections:

- To Prepare the Instrument for Use, *on page 23*
- BenchLink Data Logger Software, *on page 25*
- To Connect Wiring to a Module, *on page 27*
- To Set the Time and Date, *on page 29*
- To Configure a Channel for Scanning, *on page 30*
- To Copy a Channel Configuration, *on page 32*
- To Close a Channel, *on page 33*
- If the Instrument Does Not Turn On, *on page 34*
- To Adjust the Carrying Handle, *on page 36*
- To Rack Mount the Instrument, *on page 37*

---

## To Prepare the Instrument for Use

### 1 Check the list of supplied items.

Verify that you have received the following items with your instrument. If anything is missing, contact your nearest Agilent Technologies Sales Office or Agilent authorized reseller.

- One power cord.
- This *User's Guide*.
- One *Service Guide*.
- Certificate of Calibration (if you ordered the internal DMM).
- BenchLink Data Logger 3 Software on CD-ROM.  
*To install the software, see page 25.*
- Quick Start Package (if you ordered the internal DMM):
  - One RS-232 cable (34970A only).
  - One J-type thermocouple and a flatblade screwdriver.
- Any plug-in modules that you ordered are delivered in a separate shipping container.

### 2 Verify that the fuse on the back is set to the proper voltage range for your AC power.

### 3 Connect the power cord and turn on the instrument.



On/Standby  
Switch

#### WARNING

*Note that this switch is **Standby** only. To disconnect the mains from the instrument, remove the power cord.*

The front-panel display will light up briefly while the instrument performs its power-on self-test. The instrument initially powers up with all measurement channels turned off. To review the power-on display with all annunciators turned on, hold down  as you turn on the instrument. Note that a battery must be installed in the unit in order for it to boot up. The battery is installed when you receive the unit from the factory; this is only a consideration if you remove the battery for some reason. *If the instrument does not turn on properly, see page 34.*

**4 Perform a complete self-test.**

The *complete* self-test performs a more extensive set of tests than those performed at power-on. Hold down  as you turn on the instrument and *hold down the key until you hear a long beep*. The self-test will begin when you release the key following the beep.

*If the self-test fails, see the 34970A/34972A Service Guide for instructions on returning the instrument to Agilent for service.*



---

## BenchLink Data Logger Software

The Agilent BenchLink Data Logger 3 software comes standard with the 34970A/34972A (if the internal DMM is ordered) and provides the basic data logger capabilities. Or, for increased capabilities, purchase the optional Agilent BenchLink Data Logger Pro software. This application provides advanced data logging and decision making with no programming required.

*For system requirements and additional details on the features of the software, refer to the specifications in chapter 8.*

### **BenchLink Data Logger 3 Software Installation Procedure**

#### ***Microsoft Windows Vista/XP/2000***

1. Insert the 34825A Product CD-ROM into your drive.
2. From the Product CD-ROM window that is displayed, locate “*Agilent BenchLink Data Logger 3 Software*” in the **Software** group.
3. Click on **Install** and follow the instructions as prompted by the installation utility.

A representative screen of the software is shown below.

# Chapter 1 Quick Start

## BenchLink Data Logger Software

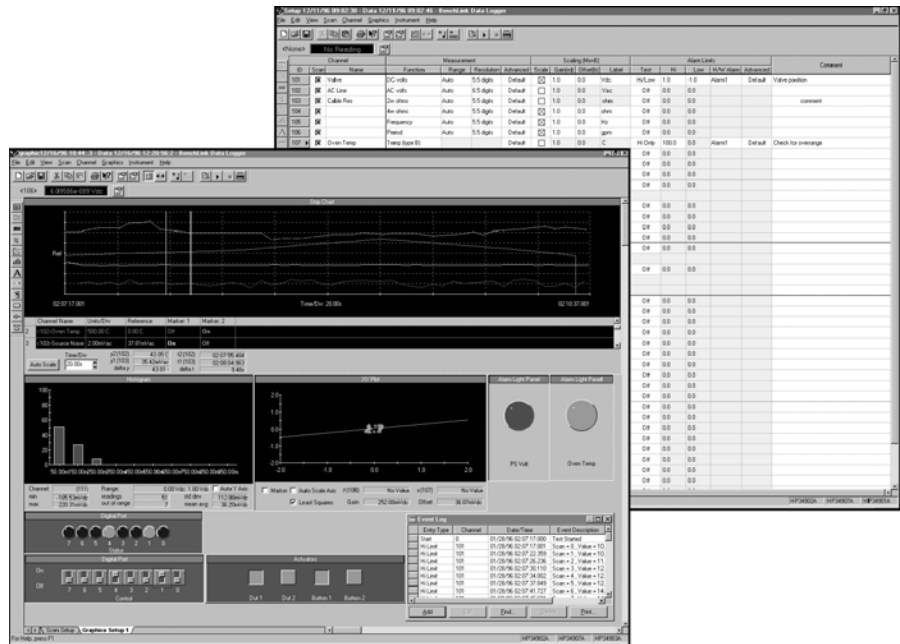

## On-Line Help System

The software is shipped with an extensive on-line Help system to help you learn the features of the software as well as troubleshoot any problems that might arise as you are using the software. As you are installing the software, you will notice that the on-line Help system is available in several languages.

## To Connect Wiring to a Module

1. Remove the module cover.

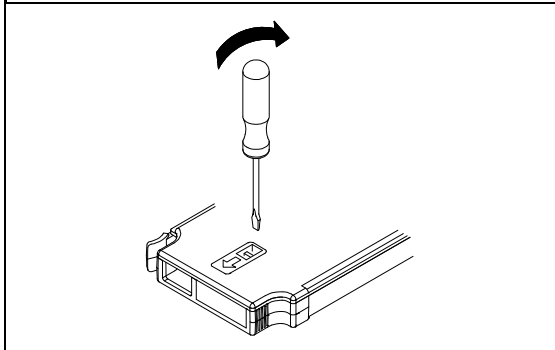

2. Connect wiring to the screw terminals.

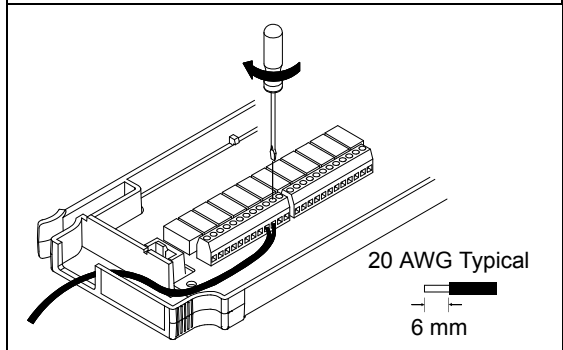

3. Route wiring through strain relief.

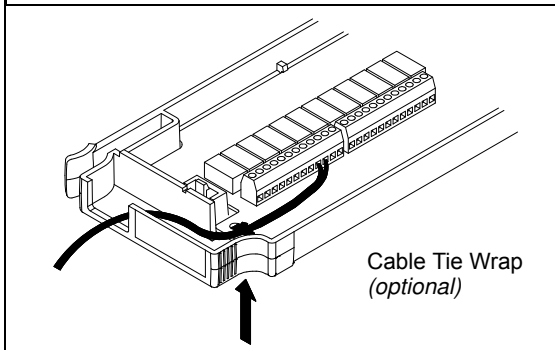

4. Replace the module cover.

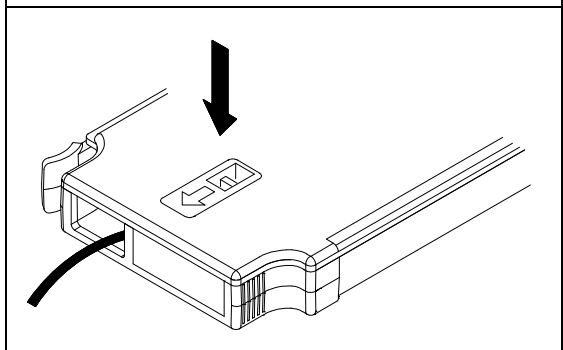

5. Install the module into mainframe.

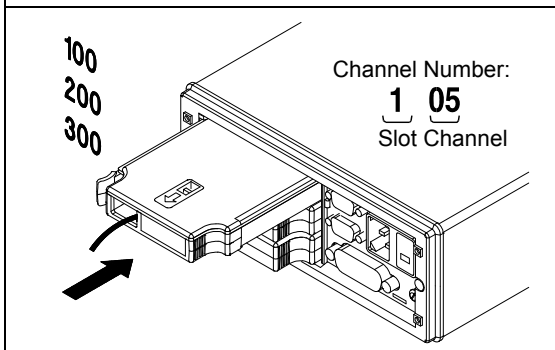

### Wiring Hints...

- For detailed information on each module, refer to the section starting on page 200.
- To reduce wear on the internal DMM relays, wire *like* functions on adjacent channels.
- For information on grounding and shielding, see page 259.
- The diagrams on page 28 show how to connect wiring to a multiplexer module for each measurement function. →

Chapter 1 Quick Start  
**To Connect Wiring to a Module**

**Thermocouple**

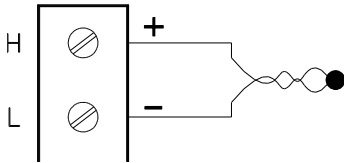

Thermocouple Types: B, E, J, K, N, R, S, T  
 See page 351 for thermocouple color codes.

**DC Voltage / AC Voltage / Frequency**

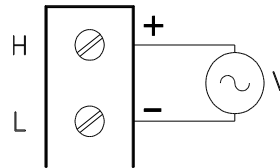

Ranges: 100 mV, 1 V, 10 V, 100 V, 300 V

**2-Wire Ohms / RTD / Thermistor**

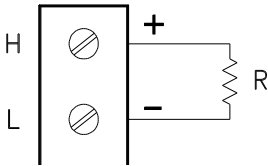

Ranges: 100, 1 k, 10 k, 100 k, 1 M, 10 M, 100 MΩ  
 RTD Types: 0.00385, 0.00391  
 Thermistor Types, 2.2 k, 5 k, 10 k

**4-Wire Ohms / RTD**

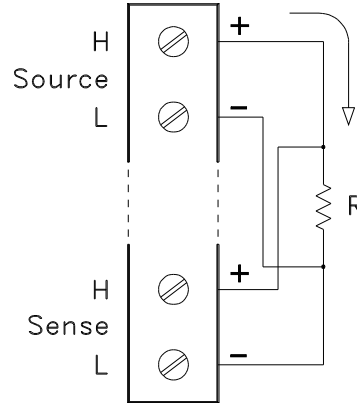

Channel *n* (source) is automatically paired with Channel *n+10* (sense) on the 34901A, or Channel *n+8* (sense) on the 34902A.

Ranges: 100, 1 k, 10 k, 100 k, 1 M, 10 M, 100 MΩ  
 RTD Types: 0.00385, 0.00391

**DC Current / AC Current**

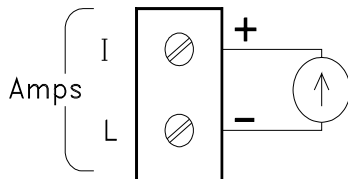

Valid only on channels 21 and 22 on the 34901A  
 Ranges: 10 mA, 100 mA, 1A



---

## To Set the Time and Date

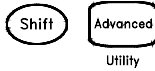
All readings during a scan are automatically time stamped and stored in non-volatile memory. In addition, alarm data is time stamped and stored in a separate non-volatile memory queue.





### 1 Set the time of day.

Use  and  to select the field to modify and turn the knob to change the value. You can also edit the AM/PM field.

TIME 03:45 PM



### 2 Set the date.

Use  and  to select the field to modify and turn the knob to change the value.

JUN 01 2009

---



## To Configure a Channel for Scanning

Any channel that can be “read” by the instrument can also be included in a scan. This includes readings on multiplexer channels, a read of a digital port, or a read of the count on a totalizer channel. Automated scanning *is not* allowed with the RF multiplexer, matrix, actuator, digital output, or voltage output (DAC) modules.



### 1 Select the channel to be added to the scan list.

Turn the knob until the desired channel is shown on the right side of front-panel display. The channel number is a three-digit number; the left-most digit represents the slot number (100, 200, or 300) and the two digits on the right indicate the channel number (102, 110, etc.).

**Note:** You can use  and  to skip to the beginning of the previous or next slot.

For this example, assume that you have the 34901A multiplexer installed in slot 100 and select channel 103.



### 2 Select the measurement parameters for the selected channel.

Use the knob to scroll through the measurement choices on each level of the menu. When you press  to make your selection, the menu automatically guides you through all relevant choices to configure a measurement on the selected function. When you have finished configuring the parameters, you are automatically exited from the menu.

The current selection (or default) is displayed in full bright for easy identification. When you make a different selection, the new choice is shown in full bright and it becomes the default selection. The order of the choices always remains the same; however, you always enter the menu at the current (full bright) setting for each parameter.

**Note:** The menu will time-out after about 20 seconds of inactivity and any changes made previously will take effect.

For this example, configure channel 103 to measure a J-type thermocouple with 0.1 °C of display resolution.

**Note:** Press  to sequentially step through the scan list and take a measurement on each channel (readings are not stored in memory). This is an easy way to verify your wiring connections before initiating the scan.



**3 Run the scan and store the readings in non-volatile memory.**



The instrument automatically scans the configured channels in consecutive order from slot 100 through slot 300 (the **SCAN** annunciator turns on). Channels that are not configured are skipped during the scan. In the default configuration, the instrument continuously scans the configured channels at a 10-second interval.





Press and hold  to stop the scan.



**4 View the data from the scan.**

All readings taken during a scan are automatically time stamped and stored in non-volatile memory. During the scan, the instrument calculates and stores the minimum, maximum, and average on all channels in the scan list. You can read the contents of memory at any time, even during a scan.

From the front panel, data is available for the last 100 readings on each channel readings taken during a scan (all of the data is available from the remote interface). From the View menu, select READINGS and press  again. Then press  and  to choose the data you want to view for the selected channel as shown in the table below.

	 and 
Select Channel	Last Reading on Channel Time of Last Reading Minimum Reading on Channel Time of Minimum Reading Maximum Reading on Channel Time of Maximum Reading Average of Readings on Channel Second Most Recent Reading on Channel Third Most Recent Reading on Channel ⋮  99th Most Recent Reading on Channel

## To Copy a Channel Configuration

After configuring a channel to be included in the scan list, you can copy that same configuration to other channels in the instrument (including digital channels on the multifunction module). This feature makes it easy to configure several channels for the same measurement. When you copy the configuration from one channel to another, the following parameters are automatically copied to the new channel:

- Measurement configuration.
- Mx+B scaling configuration.
- Alarm configuration.
- Advanced measurement configuration.



### 1 Select the channel to copy the configuration *from*.

Turn the knob until the desired channel is shown on the right side of front-panel display. For this example, let's copy the configuration from channel 103.



### 2 Select the copy function.

Use the knob to scroll through the measurement choices until you see COPY CONFIG. When you press  to make your selection, the menu automatically guides you to the next step.



### 3 Select the channel to copy the configuration *to*.

Turn the knob until the desired channel is shown on the right side of front-panel display. For this example, let's copy the configuration to channel 105.

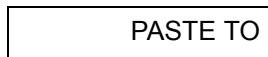

### 4 Copy the channel configuration to the selected channel.

*Note:* To copy the same configuration to other channels, repeat this procedure.





## To Close a Channel

On the multiplexer and switch modules, you can close and open individual relays on the module. However, note that if you have already configured any multiplexer channels for scanning, you cannot independently close and open individual relays on that module.



### 1 Select the channel.

Turn the knob until the desired channel is shown on the right side of front-panel display. For this example, select channel 213.









### 2 Close the selected channel.



### 3 Open the selected channel.

**Note:**  will sequentially open all channels on the module in the selected slot.

The table below shows the low-level control operations available for each of the plug-in modules.

Plug-In Module					 , 
34901A 20-Channel Mux	•	•	•		•
34902A 16-Channel Mux	•	•	•		•
34908A 40-Channel Single-Ended Mux <sup>[1]</sup>	•	•	•		•
34903A 20-Channel Actuator	•	•			
34904A 4x8 Matrix	•	•			
34905A Dual 4-Channel RF Mux (50Ω) <sup>[2]</sup>	•				
34906A Dual 4-Channel RF Mux (75Ω) <sup>[2]</sup>	•				
34907A Multifunction Module (DIO)			•	•	•
34907A Multifunction Module (Totalizer)			•		•
34907A multifunction Module (DAC)				•	

[1] Only one channel can be closed at a time on this module.

[2] Only one channel in each bank can be closed at a time on this module.

## If the Instrument Does Not Turn On

Use the following steps to help solve problems you might encounter when turning on the instrument. If you need more help, refer to the *34970A/34972A Service Guide* for instructions on returning the instrument to Agilent for service.

### **1 Verify that there is AC power to the instrument.**

First, verify that the power cord is firmly plugged into the power receptacle on the rear panel of the instrument. You should also make sure that the power source you plugged the instrument into is energized. Then, verify that the instrument is turned on.

*The On/Standby switch  is located on the lower left side of the front panel.*

### **2 Verify that there is a battery in the instrument**

A battery must be present for the instrument to boot up.

### **3 Verify the power-line voltage setting.**

The line voltage is set to the proper value for your country when the instrument is shipped from the factory. Change the voltage setting if it is not correct. The settings are: 100, 120, 220, or 240 VAC.

***Note:** For 127 VAC operation, use the 120 VAC setting.  
For 230 VAC operation, use the 220 VAC setting.*

*See the next page if you need to change the line voltage setting.*

### **4 Verify that the power-line fuse is good.**

The instrument is shipped from the factory with a 500 mA fuse installed. This is the correct fuse for all line voltages.

*See the next page if you need to replace the power-line fuse.*

*To replace the 500 mA, 250 V fuse, order Agilent part number 2110-0458.*

**1 Remove the power cord.** Remove the fuse-holder assembly from the rear panel.

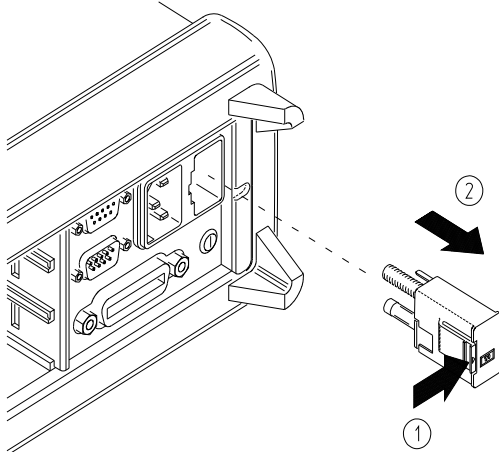

**2 Remove the line voltage selector** from the assembly.

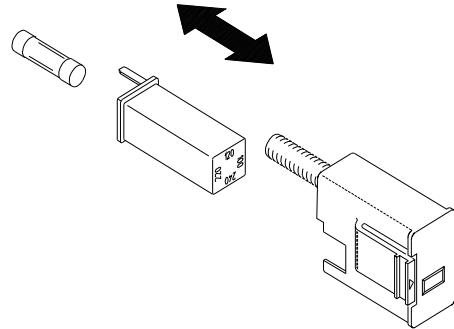

Fuse: 500 mAAT (for all line voltages)  
Agilent Part Number: 2110-0458

**3 Rotate the line-voltage selector** until the correct voltage appears in the window.

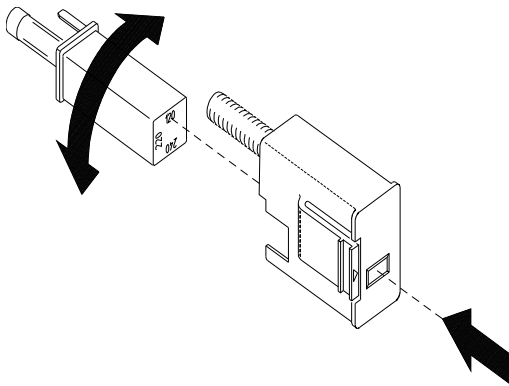

100, 120 (127), 220 (230), or 240 VAC

**4 Replace the fuse-holder assembly** in the rear panel.

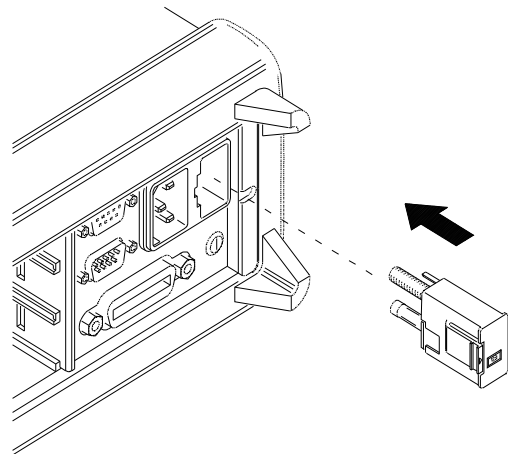

---

## To Adjust the Carrying Handle

To adjust the position, grasp the handle by the sides and *pull outward*. Then, rotate the handle to the desired position.

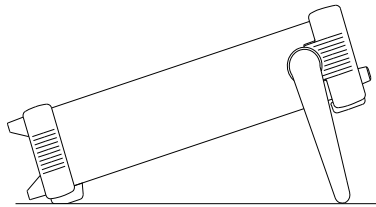
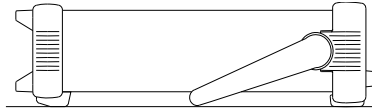

**Bench-top viewing position**

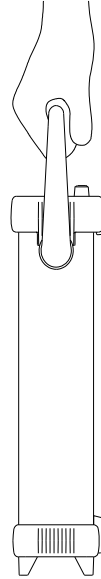

**Carrying position**

## To Rack Mount the Instrument

You can mount the instrument in a standard 19-inch rack cabinet using one of three optional kits available. Instructions and mounting hardware are included with each rack-mounting kit. Any Agilent *System II* instrument of the same size can be rack-mounted beside the 34970A/34972A.

**Note:** Remove the carrying handle, and the front and rear rubber bumpers, before rack-mounting the instrument.

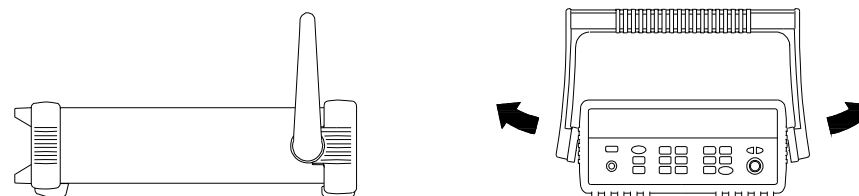

To remove the handle, rotate it to the vertical position and pull the ends outward.

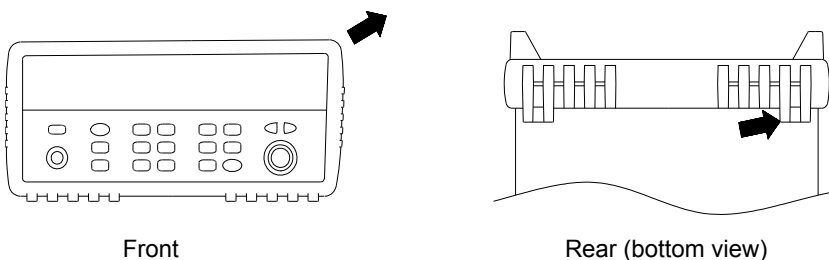

To remove the rubber bumper, stretch a corner and then slide it off.

Chapter 1 Quick Start  
**To Rack Mount the Instrument**

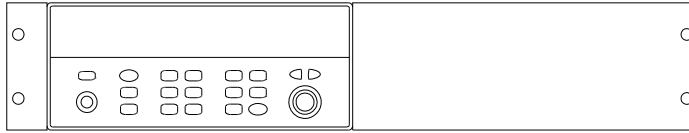

**To rack mount a single instrument, order adapter kit 5063-9240.**

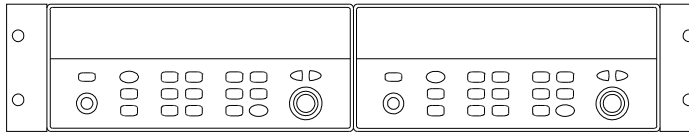

**To rack mount two instruments side-by-side, order lock-link kit 5061-9694 and flange kit 5063-9212. Be sure to use the support rails inside the rack cabinet.**

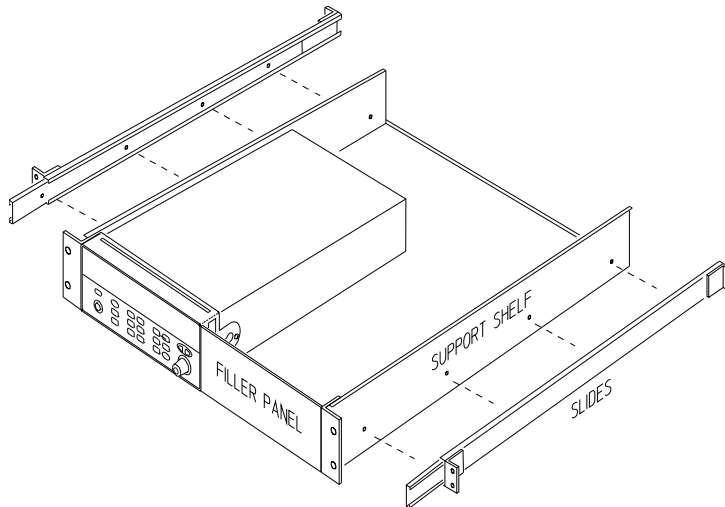

**To install one or two instruments in a sliding support shelf, order shelf 5063-9255, and slide kit 1494-0015 (for a single instrument, also order filler panel 5002-3999).**

---

## Front-Panel Overview

---

# Front-Panel Overview

This chapter introduces you to the front-panel keys and menu operation. This chapter does not give a detailed description of every front-panel key or menu operation. It does, however, give you an overview of the front-panel menus and many front-panel operations. See chapter 4 “Features and Functions,” starting on page 87, for a complete discussion of the instrument’s capabilities and operation.

This chapter is divided into the following sections:

- Front-Panel Menu Reference, *on page 41*
- To Monitor a Single Channel, *on page 44*
- To Set a Scan Interval, *on page 45*
- To Apply Mx+B Scaling to Measurements, *on page 46*
- To Configure Alarm Limits, *on page 47*
- To Read a Digital Input Port, *on page 49*
- To Write to a Digital Output Port, *on page 50*
- To Read the Totalizer Count, *on page 51*
- To Output a DC Voltage, *on page 52*
- To Configure the Remote Interface - 34970A, *on page 53*
- To Configure the Remote Interface - 34972A, *on page 55*
- To Store the Instrument State, *on page 57*



## Front-Panel Menu Reference

This section gives an overview of the front-panel menus. The menus are designed to automatically guide you through all parameters required to configure a particular function or operation. The remainder of this chapter contains examples of using the front-panel menus.



### Configure the measurement parameters on the displayed channel.

- Select the measurement function (dc volts, ohms, etc.) on the displayed channel.
- Select transducer type for temperature measurements.
- Select units (°C, °F, or K) for temperature measurements.
- Select measurement range or autorange.
- Select measurement resolution.
- Copy and paste measurement configuration to other channels.



### Configure the scaling parameters for the displayed channel.

- Set the gain ("M") and offset ("B") value for the displayed channel.
- Make a null measurement and store it as the offset value.
- Specify a custom label (RPM, PSI, etc.) for the displayed channel.



### Configure alarms on the displayed channel.

- Select one of four alarms to report alarm conditions on the displayed channel.
- Configure a high limit, low limit, or both for the displayed channel.
- Configure a bit pattern that will generate an alarm (digital input only).



### Configure the four Alarm Output hardware lines.

- Clear the state of the four alarm output lines.
- Select the "Latch" or "Track" mode for the four alarm output lines.
- Select the slope (rising or falling edge) for the four alarm output lines.

## Front-Panel Menu Reference

Interval

### Configure the event or action that controls the scan interval.

- Select the scan interval mode (interval, manual, external, or alarm).
- Select the scan count.

Advanced

### Configure the advanced measurement features on displayed channel.

- Set the integration time for measurements on the displayed channel.
- Set the channel-to-channel delay for scanning.
- Enable/disable the thermocouple check feature (T/C measurements only).
- Select the reference junction source (T/C measurements only).
- Set the low frequency limit (ac measurements only).
- Enable/disable offset compensation (resistance measurements only).
- Select the binary or decimal mode for digital operations (digital input/output only).
- Configure the totalizer reset mode (totalizer only).
- Select which edge is detected (rising or falling) for totalizer operations.

Utility

### Configure system-related instrument parameters.

- Set the real-time system clock and calendar.
- Query the firmware revisions for the mainframe and installed modules.
- Select the instrument's power-on configuration (last or factory reset).
- Enable/disable the internal DMM.
- Secure/unsecure the instrument for calibration.

View

### View readings, alarms, and errors.

- View the last 100 scanned readings from memory (last, min, max, and average).
- View the first 20 alarms in the alarm queue (reading and time alarm occurred).
- View up to 10 errors (34970A) or 20 errors (34972A) in the error queue.
- Read the number of cycles for the displayed relay (relay maintenance feature).

**Sto/Rcl** **Store and recall instrument states.**

- Store up to five instrument states in non-volatile memory.
- Assign a name to each storage location.
- Recall stored states, power-down state, factory reset state, or preset state.

**Interface** **Configure the remote interface (34970A).**

- Select the GPIB address.
- Configure the RS-232 interface (baud rate, parity, and flow control).

**Interface** **Configure the remote interface (34972A).**

- Configure the LAN settings (IP Address, Hostname, DHCP, etc.)
- Configure the USB settings (Enable, USB ID, etc.)
- Configure and use the USB drive (Logging, etc.)

---

## To Monitor a Single Channel

You can use the *Monitor* function to continuously take readings on a single channel, even during a scan. This feature is useful for troubleshooting your system before a test or for watching an important signal.



### 1 **Select the channel to be monitored.**

Only one channel can be monitored at a time but you can change the channel being monitored at any time by turning the knob.



### 2 **Enable monitoring on the selected channel.**

Any channel that can be “read” by the instrument can be monitored (the **MON** annunciator turns on). This includes any combination of temperature, voltage, resistance, current, frequency, or period measurements on multiplexer channels. You can also monitor a digital input port or the totalizer count on the multifunction module.

To disable monitoring, press  again.

---

## To Set a Scan Interval

You can set the instrument's internal timer to automatically scan at a specific interval (e.g., start a new scan sweep every 10 seconds) or when an external TTL trigger pulse is received. You can configure the instrument to scan continuously or to stop after sweeping through the scan list a specified number of times.

Interval

### 1 Select the interval scan mode.

For this example, select the *Interval Scan* mode which allows you to set the time from the start of one scan sweep to the start of the next scan sweep. Set the interval to any value between 0 and 99 hours

INTERVAL SCAN

Interval

### 2 Select the scan count.

You can specify the number of times that the instrument will sweep through the scan list (the default is continuous). When the specified number of sweeps have occurred, the scan stops. Set the scan count to any number between 1 and 50,000 scans (or continuous).

00020 SCANS

Scan

### 3 Run the scan and store the readings in memory.

---

## To Apply Mx+B Scaling to Measurements

The scaling function allows you to apply a *gain* and *offset* to all readings on a specified multiplexer channel during a scan. In addition to setting the gain (“M”) and offset (“B”) values, you can also specify a custom measurement label for your scaled readings (RPM, PSI, etc.).

Measure

### 1 Configure the channel.

You must configure the channel (function, transducer type, etc.) before applying any scaling values. If you change the measurement configuration, scaling is turned off on that channel and the gain and offset values are reset (M=1 and B=0).

Mx+B

### 2 Set the gain and offset values.

The scaling values are stored in *non-volatile* memory for the specified channels. A Factory Reset turns off scaling and clears the scaling values on all channels. An Instrument Preset or Card Reset *does not* clear the scaling values and *does not* turn off scaling.

+1.000,000

Set Gain

+0.000,000 VDC

Set Offset

Mx+B

### 3 Select the custom label.

You can specify an optional three-character label for your scaled readings (RPM, PSI, etc.). The default label is the standard engineering unit for the selected function (VDC, OHM, etc.).

LABEL AS LBS

Scan

### 4 Run the scan and store the scaled readings in memory.

## To Configure Alarm Limits

The instrument has four alarms which you can configure to alert you when a reading exceeds specified limits on a channel during a scan. You can assign a high limit, a low limit, or both to any configured channel in the scan list. You can assign multiple channels to any of the four available alarms (numbered 1 through 4).

Measure

### 1 Configure the channel.

You must configure the channel (function, transducer type, etc.) before setting any alarm limits. If you change the measurement configuration, alarms are turned off and the limit values are cleared. If you plan to use Mx+B scaling on a channel which will also use alarms, *be sure to configure the scaling values first.*

Alarm

### 2 Select which of the four alarms you want to use.

USE ALARM 1

Alarm

### 3 Select the alarm mode on the selected channel.

You can configure the instrument to generate an alarm when a measurement exceeds the specified HI or LO limits (or both) on a measurement channel.

HI ALARM ONLY

Alarm

#### 4 Set the limit value.

The alarm limit values are stored in *non-volatile* memory for the specified channels. The default values for the high and low limits are “0”. The low limit must always be less than or equal to the high limit, even if you are using only one of the limits. A Factory Reset clears all alarm limits and turns off all alarms. An Instrument Preset or Card Reset *does not* clear the alarm limits and *does not* turn off alarms.

+0.250,000 °C

Scan

#### 5 Run the scan and store the readings in memory.

If an alarm occurs on a channel as it is being scanned, then that channel’s alarm status is stored in reading memory as the readings are taken. Each time you start a new scan, the instrument clears all readings (including alarm data) stored in reading memory from the previous scan. As alarms are generated, they are also logged in an *alarm queue*, which is separate from reading memory. Up to 20 alarms can be logged in the alarm queue. Reading the alarm queue using the *View* menu clears the alarms in the queue.



## To Read a Digital Input Port

The multifunction module (34907A) has two non-isolated 8-bit input/output ports which you can use for reading digital patterns. You can read the live status of the bits on the port or you can configure a scan to include a digital read.



### 1 Select the Digital Input port.

Select the slot containing the multifunction module and continue turning the knob until DIN is displayed (channel 01 or 02).



### 2 Read the specified port.

You can specify whether you want to use binary or decimal format. Once you have selected the number base, it is used for all input or output operations on the same port. To change the number base, press the  and select USE BINARY or USE DECIMAL.

01010101 DIN

*Binary Display Shown*

The bit pattern read from the port will be displayed until you press another key, turn the knob, or until the display times out.

**Note:** To add a digital input channel to a scan list, press  and select the DIO READ choice.

---

## To Write to a Digital Output Port

The multifunction module (34907A) has two non-isolated 8-bit input/output ports which you can use for outputting digital patterns.



### 1 Select the Digital Output port.

Select the slot containing the multifunction module and continue turning the knob until DIN is displayed (channel 01 or 02).





### 2 Enter the bit pattern editor.

Notice that the port is now converted to an output port (DOUT).

*Binary Display Shown*

### 3 Edit the bit pattern.

Use the knob and  or  keys to edit the individual bit values. You can specify whether you want to use binary or decimal format. Once you have selected the number base, it is used for all input or output operations on the same port. To change the number base, press the  key and select USE BINARY or USE DECIMAL.

*Decimal Display Shown*



### 4 Output the bit pattern to the specified port.

The specified bit pattern is latched on the specified port. To cancel an output operation in progress, wait for the display to time out.

## To Read the Totalizer Count

The multifunction module (34907A) has a 26-bit totalizer which can count pulses at a 100 kHz rate. You can manually read the totalizer count or you can configure a scan to read the count.



### 1 Select the totalizer channel.

Select the slot containing the multifunction module and continue turning the knob until TOTALIZE is displayed (channel 03).



### 2 Configure the totalize mode.

The internal count starts as soon as you turn on the instrument. You can configure the totalizer to reset the count to “0” after being read or it can count continuously and be manually reset.

*READ + RESET*



### 3 Read the count.

The count is read once each time you press ; the count does not update automatically on the display. As configured in this example, the count is automatically reset to “0” each time you read it.

*12345 TOT*

The count will be displayed until you press another key, turn the knob, or until the display times out. To manually reset the totalizer count, press .

**Note:** To add a totalizer channel to a scan list, press and select the TOT READ choice.

---

## To Output a DC Voltage

The multifunction module (34907A) has two analog outputs capable of outputting calibrated voltages between  $\pm 12$  volts.



### 1 Select a DAC Output channel.

Select the slot containing the multifunction module and continue turning the knob until DAC is displayed (channel 04 or 05).



### 2 Enter the output voltage editor.

+00.000 V DAC

### 3 Set the desired output voltage.

Use the knob and ◀ or ▶ keys to edit the individual digits.

+05.250VDAC





### 4 Output the voltage from the selected DAC.

The output voltage will be displayed until you press another key or turn the knob. To manually reset the output voltage to 0 volts, press . . A rectangular button with rounded corners and the words "Card Reset" inside.

## To Configure the Remote Interface - 34970A

The 34970A is shipped with both an GPIB (IEEE-488) interface and an RS-232 interface. Only one interface can be enabled at a time. The GPIB interface is selected when the instrument is shipped from the factory.

### GPIB Configuration

-   **1 Select the GPIB interface.**

*GPIB / 488*

-   
Interface **2 Select the GPIB address.**

You can set the instrument's address to any value between 0 and 30. The factory setting is address "9".

*ADDRESS 09*

-   
Interface **3 Save the change and exit the menu.**

**Note:** Your computer's GPIB interface card has its own address. Be sure to avoid using the computer's address for any instrument on the interface bus. Agilent's GPIB interface cards generally use address "21".

**RS-232 Configuration**

Shift

Sto/Rcl

**1 Select the RS-232 interface.**

RS-232

Sto/Rcl

Interface

**2 Select the baud rate.**

Select one of the following: 1200, 2400, 4800, 9600, 19200, 38400, 57600 (*factory setting*), or 115200 baud.

19200 BAUD

Sto/Rcl

Interface

**3 Select the parity and number of data bits.**

Select one of the following: None (8 data bits, *factory setting*), Even (7 data bits), or Odd (7 data bits). When you set the parity, you are also indirectly setting the number of data bits.

EVEN, 7 BITS

Sto/Rcl

Interface

**4 Select the flow control method.**

Select one of the following: None (no flow control), RTS/CTS, DTR/DSR, XON/XOFF (*factory setting*), or Modem.

FLOW DTR/DSR

Sto/Rcl

Interface

**5 Save the changes and exit the menu.**

---

## To Configure the Remote Interface - 34972A

The instrument is shipped with both a Local Area Network (LAN) interface and a Universal Serial Bus (USB) interface. Both interfaces can be enabled at the same time and both interfaces are selected when the instrument is shipped from the factory.

### LAN Configuration

- Shift** **Sto/Rcl** **1 Select the LAN interface.**

*LAN INTERFACE*

- Sto/Rcl**  
Interface **2 Enable the LAN.**  
This is enabled by default.

*LAN ENABLED*

- 3 Configure the instrument LAN settings according the instructions provided by your LAN administrator.**

**USB Configuration**



**1 Select the USB interface.**



*USB INTERFACE*



**2 Enable or disable the USB interface.**

Select either USB ENABLED or USB DISABLED.



*USB ENABLED*



**3 View the USB ID String**

The instrument will display its USB identification (USB ID) string. This is helpful in identifying the device on the USB network. Use the left and right arrows above the knob to view the full string.

*USB0::2391::8199::MY01023529::0::INSTR*



**4 Save the changes and exit the menu.**



---

## To Store the Instrument State

You can store the instrument state in one of five non-volatile storage locations. A sixth storage location automatically holds the power-down configuration of the instrument. When power is restored, the instrument can automatically return to its state before power-down (a scan in progress before power-down will also be resumed).

Sto/Rcl

### 1 Select the storage location.

From the front panel, you have the ability to assign names (up to 12 characters) to each of the five stored states.

*NAME STATE*

*1: TEST\_RACK\_2*

The storage locations are numbered 1 through 5. The power-down state is automatically stored and can be recalled from the front panel (the state is named LAST PWR DOWN).

*STORE STATE*

*2: STATE2*

Sto/Rcl

### 2 Store the instrument state.

The instrument stores all channel configurations, alarm values, scaling values, scan interval setups, and advanced measurement configurations.

*CHANGE SAVED*



---

## System Overview

---

# System Overview

This chapter provides an overview of a computer-based system and describes the parts of a data acquisition system. This chapter is divided into the following sections:

- Data Acquisition System Overview, see below.
- Signal Routing and Switching, *on page 70*
- Measurement Input, *on page 74*
- Control Output, *on page 83*

---

## Data Acquisition System Overview

You can use the Agilent 34970A/34972A as a stand-alone instrument, but there are many applications where you will want to take advantage of the built-in PC connectivity features. A typical data acquisition system is shown below.

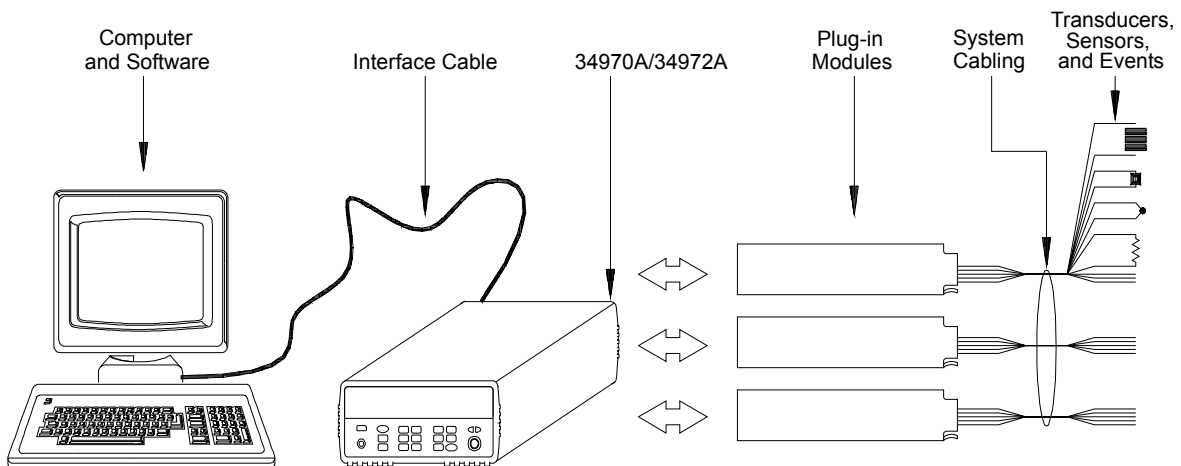

The configuration on the previous page offers the following advantages:

- You can use the 34970A/34972A to perform data storage, data reduction, mathematical calculations, and conversion to engineering units. You can use the PC to provide easy configuration and data presentation.
- You can remove the analog signals and measurement sensors from the noisy PC environment and electrically isolate them from both the PC and earth ground.
- You can use a single PC to monitor multiple instruments and measurement points while performing other PC-based tasks.

### The Computer and Interface Cable (34970A only)

Computers and operating systems are not discussed in this chapter. In addition to the computer and operating system, you will need a serial port (RS-232) or GPIB port (IEEE-488) and an interface cable.

Serial (RS-232)		GPIB (IEEE-488)	
Advantages	Disadvantages	Advantages	Disadvantages
Often built into the computer; no additional hardware is required.	Cable length is limited to 45 ft (15 m).*	Speed; faster data and command transfers.	Cable length is limited to 60 ft. (20m).*
Drivers usually included in the operating system.	Only one instrument or device can be connected per serial port	Additional system flexibility, multiple instruments can be connected to the same GPIB port.	Requires an expansion slot plug-in card in PC and associated drivers.
Cables readily available and inexpensive.  The 34970A is shipped with a serial cable (if internal DMM is ordered).	Cabling is susceptible to noise, causing slow or lost communications.  Varying connector types and styles	Direct Memory Transfers are possible.	Requires special cable
	Data transfers up to 85,000 characters/sec.	Data transfers up to 750,000 characters/sec.	

\* You can overcome these cable length limitation using special communications hardware. For example, you can use the Agilent E5810A LAN-to-GPIB Gateway interface or a serial modem.

## Measurement Software

A variety of software is available to configure your data acquisition hardware and manipulate and display your measurement data.

One particularly useful feature is 34972A's Web Interface. Simply enter the IP address of your instrument in your browser's navigation bar to launch the Web Interface.

The remote control page of the Web Interface, shown below, allows you to monitor your instrument, set up and initiate scans, save data to the USB drive, and much more. For help, simply click on the large question mark on the far left side of the screen.

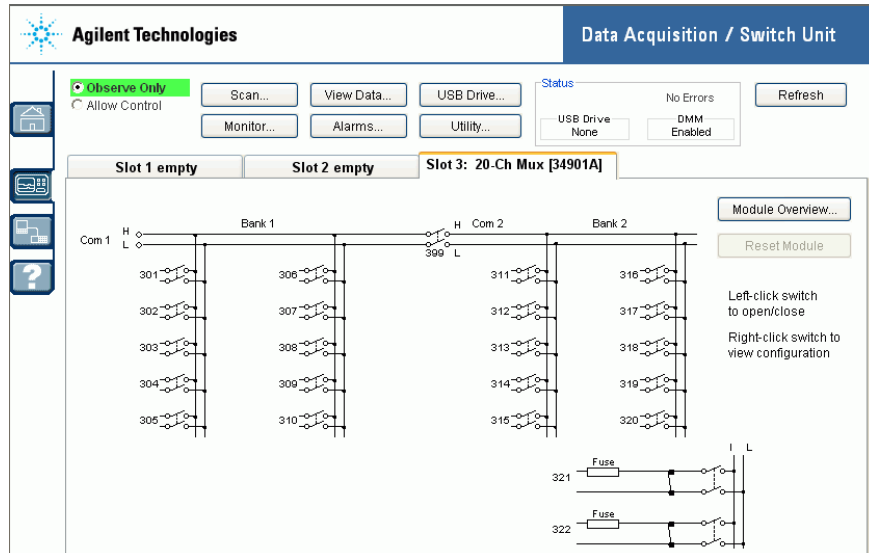

### Data Logging and Monitoring

*Agilent BenchLink Data Logger 3*, which is included with your 34970A/34972A is a Windows®-based application that makes it easy to use the instrument with your PC for gathering and analyzing measurements. Use this software to set up your test, acquire and archive measurement data, and perform real-time display and analysis of your measurements.

The *Agilent BenchLink Data Logger Pro* option, available at additional cost, provides advanced data logging and decision making with no programming required.

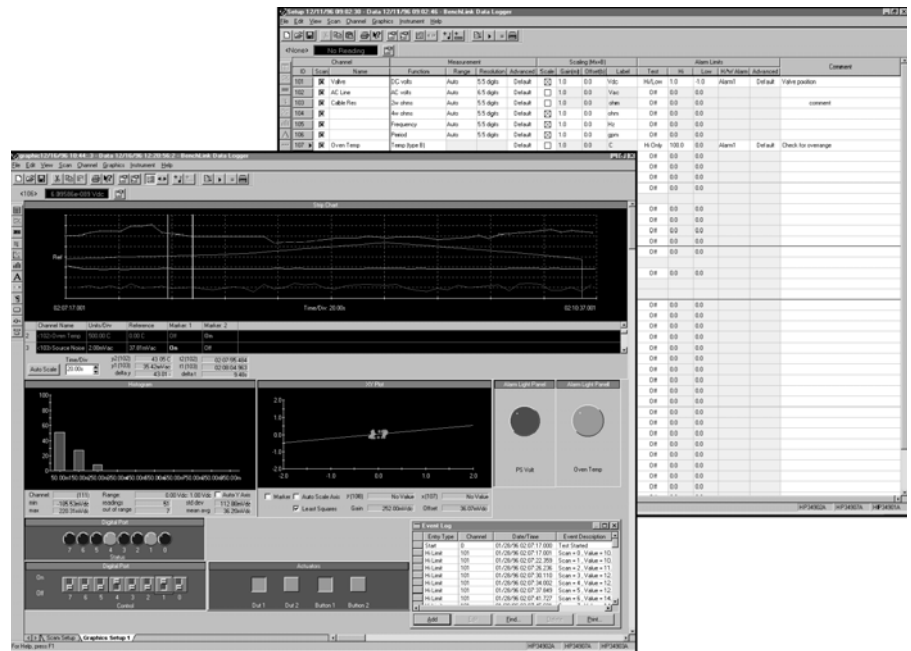

### Automated Testing with Multiple Instruments

- Agilent VEE
- TransEra HTBASIC® for Windows
- National Instruments LabVIEW
- Microsoft® Visual Basic or Visual C++

## The 34970A/34972A Data Acquisition/Switch Unit

As shown below, the logic circuitry for the 34970A/34972A is divided into two sections: *earth-referenced* and *floating*. These two sections are isolated from each other in order to maintain measurement accuracy and repeatability (*for more information on ground loops, see page 263*).

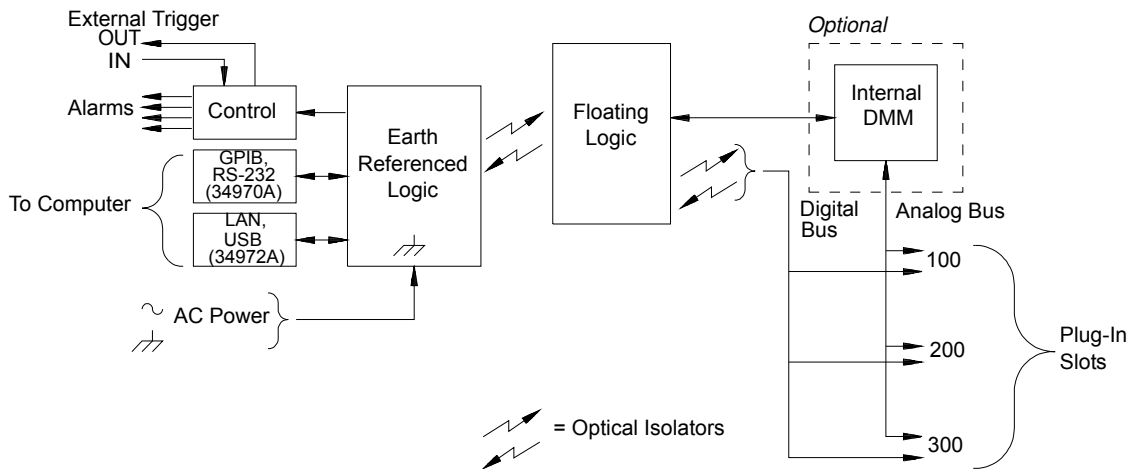

The earth-referenced and floating circuitry communicate with each other via an optically-isolated data link. The earth-referenced section communicates with the floating section to provide PC connectivity. The 34970A is shipped with both an GPIB (IEEE-488) interface and an RS-232 interface. Only one interface can be enabled at a time. The 34972A is shipped with Local Area Network (LAN) and Universal Serial Bus (USB) connectivity.

The earth-referenced section also provides four hardware alarm outputs and external trigger lines. You can use the alarm output lines to trigger external alarm lights, sirens, or send a TTL pulse to your control system.



The floating section contains the main system processor and controls all of the basic functionality of the instrument. This is where the instrument communicates with the plug-in modules, scans the keyboard, controls the front-panel display, and controls the internal DMM. The floating section also performs Mx+B scaling, monitors alarm conditions, converts transducer measurements to engineering units, time stamps scanned measurements, and stores data in non-volatile memory.

### Plug-In Modules

The 34970A/34972A offers a complete selection of plug-in modules to give you high-quality measurement, switching, and control capabilities. The plug-in modules communicate with the floating logic via the internal isolated digital bus. The multiplexer modules also connect to the internal DMM via the internal analog bus. Each module has its own microprocessor to offload the mainframe processor and minimize backplane communications for faster throughput. The table below shows some common uses for each plug-in module.

*For more information on each module, refer to the module sections in chapter 4, starting on page 200.*

Chapter 3 System Overview  
**Data Acquisition System Overview**

Model Number	Module Name	Common Uses
<b>Measurement Input</b>		
34901A	20-Channel Mux with T/C Compensation	Scanning and direct measurement of temperature, voltage, resistance, frequency, and current (34901A only) using the internal DMM.
34902A	16-Channel Reed Mux with T/C Compensation	
34908A	40-Channel Single-Ended Mux with T/C Compensation	Scanning and direct measurement of temperature, voltage, and resistance using the internal DMM.
34907A	Multifunction Module	Digital Input, Event Counting.
<b>Signal Routing</b>		
34901A	20-Channel Mux with T/C Compensation	Multiplexing of signals to or from external instruments.
34902A	16-Channel Reed Mux with T/C Compensation	
34908A	40-Channel Single-Ended Mux with T/C Compensation	
34904A	4x8 Matrix Switch	32 Crosspoint Matrix switching.
34905A	Dual 4-Channel RF Mux (50Ω)	50Ω high-frequency applications (<2 GHz).
34906A	Dual 4-Channel RF Mux (75Ω)	75Ω high-frequency applications (<2 GHz).
<b>Control Output</b>		
34903A	20-Channel Actuator	General-purpose switching and control using Form C (SPDT) switches.
34907A	Multifunction Module	Digital Output, Voltage (DAC) Outputs.

## System Cabling

The plug-in modules have screw-terminal connectors to make it easy to connect your system cabling. The type of cabling that you use to connect your signals, transducers, and sensors to the module is critical to measurement success. Some types of transducers, such as thermocouples, have very specific requirements for the type of cable that can be used to make connections. Be sure to consider the usage environment when choosing wire gauge and insulation qualities. Wire insulation typically consists of materials such as PVC or PTFE. The table below lists several common cable types and describes their typical uses.

***Note:** Wiring insulation and usage is described in more detail in "System Cabling and Connections" starting on page 257.*

## Transducers and Sensors

Transducers and sensors convert a physical quantity into an electrical quantity. The electrical quantity is measured and the result is then converted to engineering units. For example, when measuring a thermocouple, the instrument measures a DC voltage and mathematically converts it to a corresponding temperature in °C, °F, or K.

Measurement	Typical Transducer Types	Typical Transducer Output
Temperature	Thermocouple	0 mV to 80 mV
	RTD	2-wire or 4-wire resistance from 5Ω to 500Ω
	Thermistor	2-wire resistance from 10Ω to 1 MΩ
Pressure	Solid State	+/-10 VDC
Flow	Rotary Type Thermal Type	4 mA to 20 mA
Strain	Resistive Elements	4-wire resistance from 10Ω to 10 kΩ
Events	Limit Switches Optical Counters Rotary Encoder	0V or 5V Pulse Train
Digital	System Status	TTL Levels

## Alarm Limits

The 34970A/34972A has four alarm outputs which you can configure to alert you when a reading exceeds specified limits on a channel during a scan. You can assign a high limit, a low limit, or both to any configured channel in the scan list. You can assign multiple channels to any of the four available alarms (numbered 1 through 4). For example, you can configure the instrument to generate an alarm on Alarm 1 when a limit is exceeded on any of channels 103, 205, or 320.

You can also assign alarms to channels on the multifunction module. For example, you can generate an alarm when a specific bit pattern or bit pattern change is detected on a digital input channel or when a specific count is reached on a totalizer channel. With the multifunction module, the channels *do not* have to be part of the scan list to generate an alarm.

## Signal Routing and Switching

The switching capabilities of the plug-in modules available with the 34970A/34972A provide test system flexibility and expandability. You can use the switching plug-in modules to route signals to and from your test system or multiplex signals to the internal DMM or external instruments.

Relays are electromechanical devices which are subject to wear-out failure modes. The life of a relay, or the number of actual operations before failure, is dependent upon how it is used – applied load, switching frequency, and environment. The 34970A/34972A *Relay Maintenance System* automatically counts the cycles of each relay in the instrument and stores the total count in non-volatile memory on each switch module. Use this feature to track relay failures and to predict system maintenance requirements. *For more information on using this feature, refer to Relay Cycle Count, on page 169*

### Switching Topologies

Several switching plug-in modules are available with different topologies for various applications. The following switching topologies are available:

- Multiplexer (34901A, 34902A, 34905A, 34906A, 34908A)
- Matrix (34904A)
- Form C – Single Pole, Double Throw (34903A)

The following sections describe each of these switching topologies.

**Multiplexer Switching** Multiplexers allow you to connect one of multiple channels to a common channel, one at a time. A simple 4-to-1 multiplexer is shown below. When you combine a multiplexer with a measurement device, like the internal DMM, you create a scanner. *For more information on scanning, see page 77.*

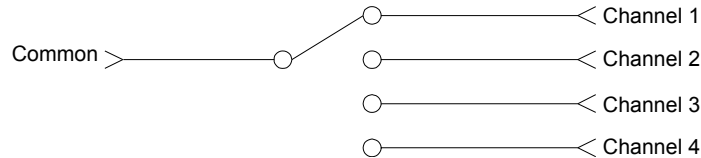

Multiplexers are available in several types:

- *One-Wire (Single-Ended) Multiplexers* for common LO measurements. *For more information, see page 301.*
- *Two-Wire Multiplexers* for floating measurements. *For more information, see page 301.*
- *Four-Wire Multiplexers* for resistance and RTD measurements. *For more information, see page 302.*
- *Very High Frequency (VHF) Multiplexers* for switching frequencies up to 2.8 GHz. *For more information, see page 312.*

## Chapter 3 System Overview

### Signal Routing and Switching

**Matrix Switching** A matrix switch connects multiple inputs to multiple outputs and therefore offers more switching flexibility than a multiplexer. Use a matrix for switching low-frequency (less than 10 MHz) signals only. A matrix is arranged in rows and columns. For example, a simple 3x3 matrix could be used to connect three sources to three test points as shown below.

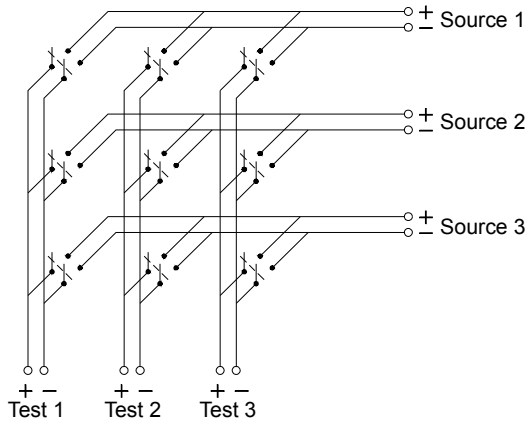

Any one of the signal sources can be connected to any one of the test inputs. Be aware that with a matrix, it is possible to connect more than one source at the same time. It is important to make sure that dangerous or unwanted conditions are not created by these connections.



**Form C (SPDT) Switching** The 34903A Actuator contains 20 Form C switches (also called *single-pole, double-throw*). You can use Form C switches to route signals but they are typically used to control external devices.

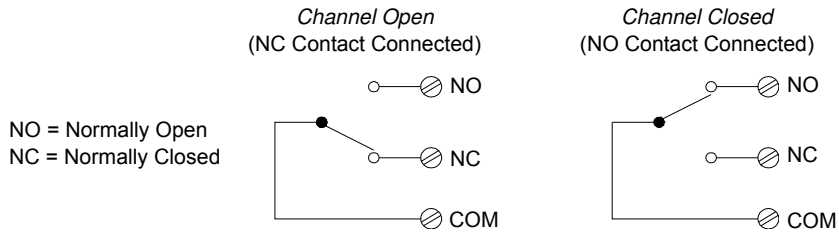

## Measurement Input

The 34970A/34972A allows you to combine a DMM (either internal or external) with multiplexer channels to create a *scan*. During a scan, the instrument connects the DMM to the configured multiplexer channels one at a time and makes a measurement on each channel.

Any channel that can be “read” by the instrument can also be included in a scan. This includes any combination of temperature, voltage, resistance, current, frequency, or period measurements on multiplexer channels. A scan can also include a read of a digital port or a read of the totalizer count on the multifunction module.

### The Internal DMM

A transducer or sensor converts a physical quantity being measured into an electrical signal which can be measured by the internal DMM. To make these measurements, the internal DMM incorporates the following functions:

- Temperature (thermocouple, RTD, and thermistor)
- Voltage (dc and ac up to 300V)
- Resistance (2-wire and 4-wire up to 100 M $\Omega$ )
- Current (DC and AC up to 1A)
- Frequency and Period (up to 300 kHz)

The internal DMM provides a universal input front-end for measuring a variety of transducer types without the need for additional external signal conditioning. The internal DMM includes signal conditioning, amplification (or attenuation), and a high resolution (up to 22 bits) analog-to-digital converter. A simplified diagram of the internal DMM is shown below.

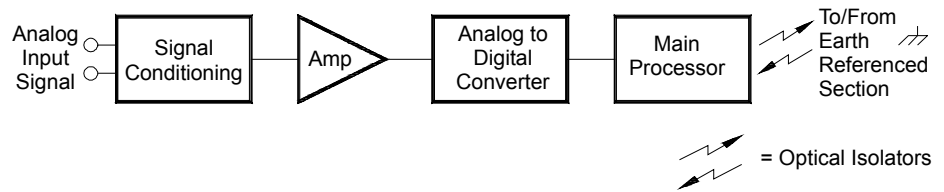

***Signal Conditioning, Ranging, and Amplification*** Analog input signals are multiplexed into the internal DMM's signal-conditioning section – typically comprising switching, ranging, and amplification circuitry. If the input signal is a DC voltage, the signal conditioner is composed of an attenuator for the higher input voltages and a DC amplifier for the lower input voltages. If the input signal is an AC voltage, a converter is used to convert the AC signal to its equivalent DC value (true RMS value). Resistance measurements are performed by supplying a known DC current to an unknown resistance and measuring the DC voltage drop across the resistor. The input signal switching and ranging circuitry, together with the amplifier circuitry, convert the input to a DC voltage which is within the measuring range of the internal DMM's analog-to-digital converter (ADC).

You can allow the instrument to automatically select the measurement range using *autoranging* or you can select a fixed measurement range using *manual ranging*. Autoranging is convenient because the instrument automatically selects the range to use for each measurement based on the input signal. For fastest scanning operation, use manual ranging for each measurement (some additional time is required for autoranging since the instrument has to make a range selection).

***Analog-to-Digital Conversion (ADC)*** The ADC takes a prescaled DC voltage from the signal-conditioning circuitry and converts it to digital data for output and display on the front panel. The ADC governs some of the most basic measurement characteristics. These include measurement resolution, reading speed, and the ability to reject spurious noise. There are several analog-to-digital conversion techniques but they can be divided into two types: *integrating and non-integrating*. The integrating techniques measure the average input value over a defined time interval, thus rejecting many noise sources. The non-integrating techniques sample the instantaneous value of the input, plus noise, during a very short interval. The internal DMM uses an integrating ADC technique.

You can select the resolution and reading speed from 6 digits (22 bits) at 3 readings per second to 4 digits (16 bits) at up to 600 readings per second. The *Advanced* menu from the 34970A/34972A front panel allows you to control the integration period for precise rejection of noise signals.

**Main Processor** The main processor, located in the floating logic section, controls the input signal conditioning, ranging, and the ADC. The main processor accepts commands from, and sends measurement results to, the earth-referenced logic section. The main processor synchronizes measurements during scanning and control operations. The main processor uses a multi-tasking operating system to manage the various system resources and demands.

The main processor also calibrates measurement results, performs Mx+B scaling, monitors alarm conditions, converts transducer measurements to engineering units, time stamps scanned measurements, and stores data in non-volatile memory.

## Scanning

The instrument allows you to combine a DMM (either internal or external) with multiplexer channels to create a *scan*. During a scan, the instrument connects the DMM to the configured multiplexer channels one at a time and makes a measurement on each channel.

Before you can initiate a scan, you must set up a *scan list* to include all desired multiplexer or digital channels. Channels which are not in the scan list are skipped during the scan. The instrument automatically scans the list of channels in ascending order from slot 100 through slot 300. Measurements are taken only during a scan and only on those channels which are included in the scan list.

You can store up to 50,000 readings in non-volatile memory during a scan. Readings are stored only during a scan and all readings are automatically time stamped. Each time you start a new scan, the instrument clears all readings stored in memory from the previous scan. Therefore, all readings currently stored in memory are from the most recent scan.

## Chapter 3 System Overview

### Measurement Input

You can configure the event or action that controls the onset of each sweep through the scan list (a *sweep* is one pass through the scan list):

- You can set the instrument's internal timer to automatically scan at a specific interval as shown below. You can also program a time delay between channels in the scan list.

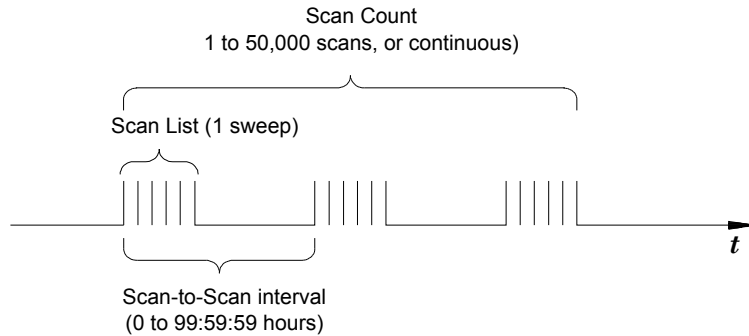

- You can manually control a scan by repeatedly pressing **Scan** from the front panel.
- You can start a scan by sending a software command from the remote interface.
- You can start a scan when an external TTL trigger pulse is received.
- You can start a scan when an alarm condition is logged on the channel being monitored.

### Scanning with External Instruments

If your application doesn't require the built-in measurement capabilities of the 34970A/34972A, you can order it without the internal DMM. In this configuration, you can use the 34970A/34972A for signal routing or control applications. If you install a multiplexer plug-in module, you can use the 34970A/34972A for scanning with an external instrument. You can connect an external instrument (such as a DMM) to the multiplexer COM terminal.

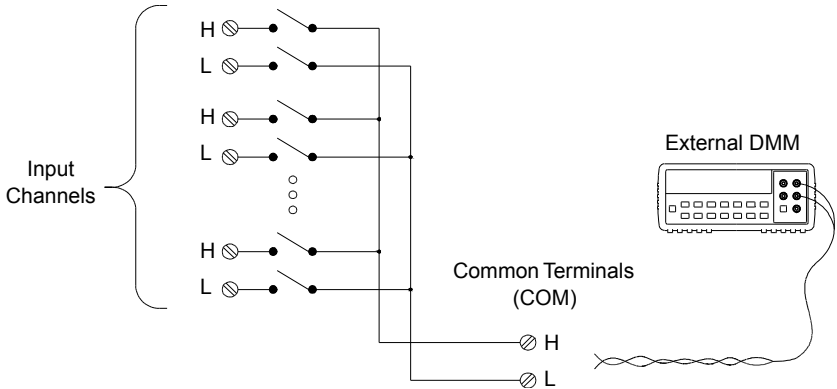

## Chapter 3 System Overview

### Measurement Input

To control scanning with an external instrument, two control lines are provided. When the 34970A/34972A and the external instrument are properly configured, you can synchronize a scan sequence between the two.

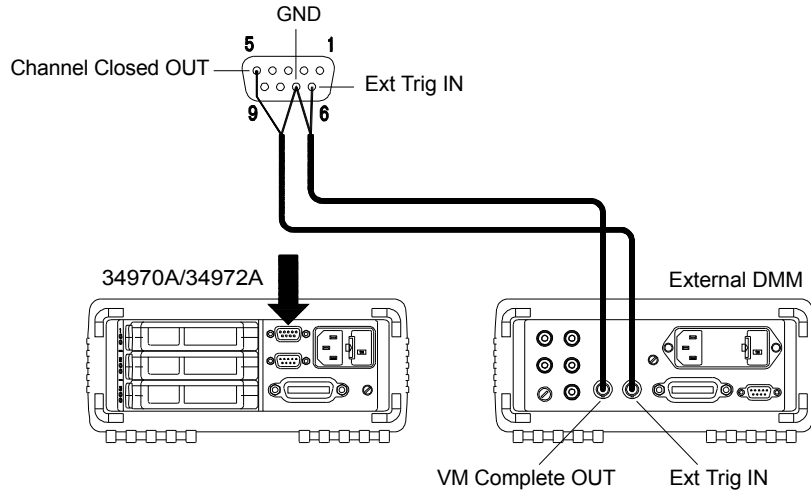



## The Multifunction Module

The multifunction module (34907A) adds two additional measurement input capabilities to the system: *digital input* and *event totalize*.

*The multifunction module also contains a dual voltage output (DAC) which is described in more detail on page 68.*

**Digital Input** The multifunction module has two non-isolated 8-bit input/output ports which you can use for reading digital patterns. You can read the live status of the bits on the port or you can configure a scan to include a digital read. Each port has a separate channel number on the module and contains 8-bits. You can combine the two ports to read a 16-bit word.

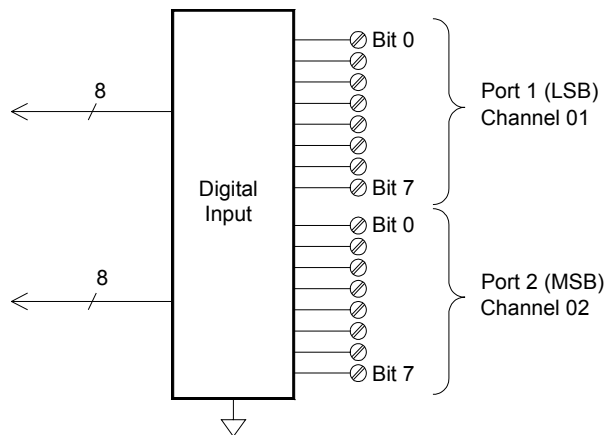

## Chapter 3 System Overview

### Measurement Input

**Totalizer** The multifunction module has a 26-bit totalizer which can count pulses at a 100 kHz rate. You can manually read the totalizer count or you can configure a scan to read the count.

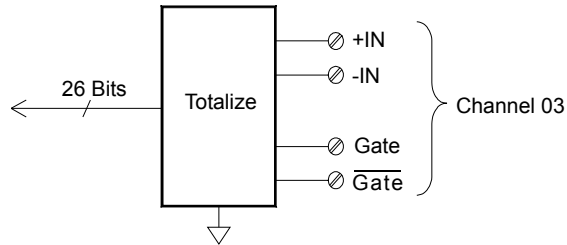

- You can configure the totalizer to count on the rising edge or falling edge of the input signal.
- The maximum count is 67,108,863 ( $2^{26} - 1$ ). The count rolls over to "0" after reaching the maximum allowed value.
- You can configure the totalizer to read without affecting the count or reset the count to zero without losing any counts.

## Control Output

In addition to signal routing and measurement, you can also use the 34970A/34972A to provide simple control outputs. For example, you can control external high-power relays using the actuator module or a digital output channel.

### The Multifunction Module

The multifunction module (34907A) adds two additional control output capabilities to the system: *digital output* and *voltage (DAC) output*.

*The multifunction module also contains digital input and event totalizer capabilities which are described in more detail starting on page 81.*

**Digital Output** The multifunction module has two non-isolated 8-bit input/output ports which you can use to output digital patterns. Each port has a separate channel number on the module and contains 8-bits. You can combine the two ports to output a 16-bit word.

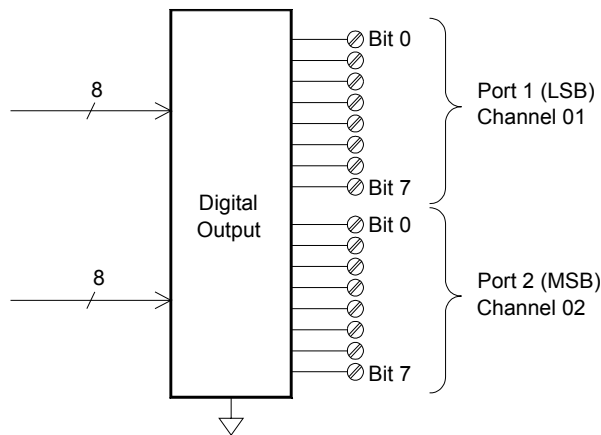

## Chapter 3 System Overview

### Control Output

**Voltage (DAC) Output** The multifunction module has two analog outputs capable of outputting calibrated voltages between  $\pm 12$  volts with 16 bits of resolution. Each DAC (*Digital-to-Analog Converter*) channel can be used as a programmable voltage source for analog input control of other devices. A simplified diagram is shown below.

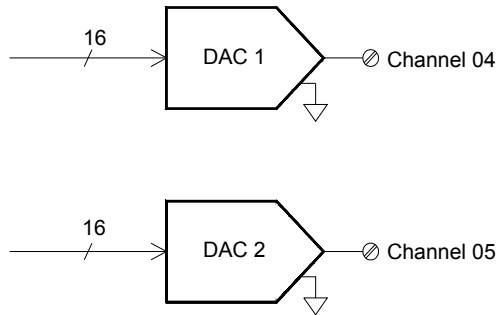

- You can set the output voltage to any value between +12 VDC and -12 VDC, in 1 mV steps. Each DAC is earth referenced; *it cannot float*.
- Each DAC channel is capable of supplying 10 mA maximum current.

**Note:** *You must limit the output current to 40 mA total for all three slots (six DAC channels).*

### The Actuator / General Purpose Switch

You can think of the 34903A Actuator as a control output because it is often used to control external power devices. The actuator provides 20 independent, isolated *Form C* (SPDT) switches.

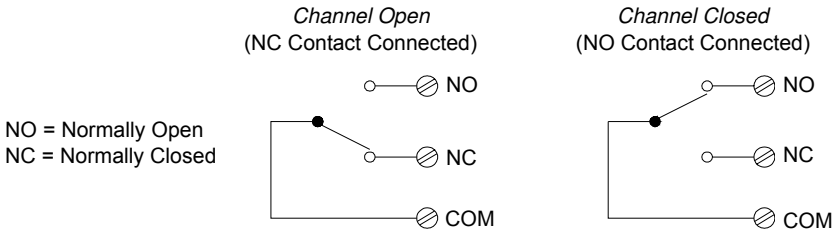

Each channel can switch up to 300V DC or AC rms. Each switch can also switch up to 1 A DC or AC rms up to 50 W maximum. For example, the maximum current that you can switch at 120 V is 0.45 A as shown below.

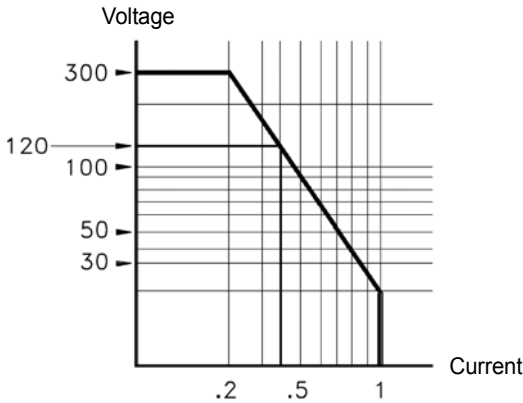

## Control Output

For control applications, the actuator has the following advantages:

- Higher voltage and power rating than the digital output channels. The actuator switches can also be used to control power devices.
- When used with high-power devices, however, it is critical that you provide protection to the switch from capacitive and inductive loads to ensure maximum relay life (*for more information on attenuators, see the discussion on page 309*).

---

## Features and Functions

---

# Features and Functions

You will find that this chapter makes it easy to look up all the details about a particular feature of the 34970A/34972A. Whether you are operating the instrument from the front panel or over the remote interface, this chapter will be useful. This chapter is divided into the following sections:

- SCPI Language Conventions, *on page 89*
- Scanning, *on page 90*
- 
- Scanning with External Instruments, *on page 111*
- General Measurement Configuration, *on page 115*
- Temperature Measurement Configuration, *on page 123*
- Voltage Measurement Configuration, *on page 130*
- Resistance Measurement Configuration, *on page 132*
- Current Measurement Configuration, *on page 133*
- Frequency Measurement Configuration, *on page 135*
- Mx+B Scaling, *on page 136*
- Alarm Limits, *on page 139*
- Digital Input Operations, *on page 151*
- Totalizer Operations, *on page 153*
- Digital Output Operations, *on page 157*
- DAC Output Operations, *on page 159*
- System-Related Operations, *on page 160*
- Single-Channel Monitoring, *on page 171*
- Mass Memory (USB) Subsystem - 34972A, *on page 174*
- USB Drive Front Panel - 34972A, *on page 181*
- Remote Interface Configuration - 34970A, *on page 183*
- Remote Interface Configuration - 34972A, *on page 188*
- Calibration Overview, *on page 192*
- Factory Reset State, *on page 197*
- Instrument Preset State, *on page 198*
- Multiplexer Module Default Settings, *on page 199*
- Module Overview, *on page 200*
- 34901A 20-Channel Multiplexer, *on page 201*
- 34902A 16-Channel Multiplexer, *on page 203*
- 34903A 20-Channel Actuator, *on page 205*
- 34904A 4x8 Matrix Switch, *on page 207*
- 34905A/6A Dual 4-Channel RF Multiplexers, *on page 209*
- 34907A Multifunction Module, *on page 211*
- 34908A 40-Channel Single-Ended Multiplexer, *on page 213*



---

## SCPI Language Conventions

Throughout this manual, the following conventions are used for SCPI command syntax for remote interface programming:

- Square brackets ( [ ] ) indicate optional keywords or parameters.
- Braces ( { } ) enclose parameter choices within a command string.
- Triangle brackets ( < > ) separate parameters for which you must substitute a value
- A vertical bar ( | ) separates multiple parameter choices.

### Rules for Using a Channel List

Many of the SCPI commands for the 34970A/34972A include a *scan\_list* or *ch\_list* parameter, which allow you to specify one or more channels. The channel number has a form (@**scc**), where **s** is the slot number (100, 200, or 300) and **cc** is the channel number. You can specify a single channel, multiple channels, or a range of channels as shown below.

- The following command configures a scan list to include only channel 10 on the module in slot 300.

```
ROUT:SCAN (@310)
```

- The following command configures a scan list to include multiple channels on the module in slot 200. The scan list now contains only channels 10, 12, and 15 (*the scan list is redefined each time you send a new ROUTe:SCAN command*).

```
ROUT:SCAN (@210,212,215)
```

- The following command configures a scan list to include a range of channels. When you specify a range of channels, the range *may* contain invalid channels (they are ignored), but the first and last channel in the range must be valid. The scan list now contains channels 5 through 10 (slot 100) and channel 15 (slot 200).

```
ROUT:SCAN (@105:110,215)
```

---

## Scanning

The instrument allows you to combine a DMM (either internal or external) with multiplexer channels to create a *scan*. During a scan, the instrument connects the DMM to the configured multiplexer channels one at a time and makes a measurement on each channel.

Any channel that can be “read” by the instrument can also be included in a scan. This includes any combination of temperature, voltage, resistance, current, frequency, or period measurements on multiplexer channels. A scan can also include a read of a digital port or a read of the totalizer count on the multifunction module. Scanning is allowed with the following modules:

- 34901A 20-Channel Multiplexer
- 34902A 16-Channel Multiplexer
- 34907A Multifunction Module (digital input and totalizer only)
- 34908A 40-Channel Single-Ended Multiplexer

Automated scanning *is not* allowed with the actuator module, the matrix module, or the RF multiplexer modules. In addition, a scan cannot include a write to a digital port or a voltage output from a DAC channel. However, you can write your own program to manually create a “scan” to include these operations.

### Rules for Scanning

- Before you can initiate a scan, you must set up a *scan list* to include all desired multiplexer or digital channels. Channels which are not in the scan list are skipped during the scan. The instrument automatically scans the list of channels in ascending order from slot 100 through slot 300. Measurements are taken only during a scan and only on those channels which are included in the scan list. The “✕” (sample) annunciator turns on during each measurement.

- You can store up to 50,000 readings in non-volatile memory during a scan. Readings are stored only during a scan and all readings are automatically time stamped. If memory overflows (the **MEM** annunciator will turn on), a status register bit is set and new readings will overwrite the first readings stored (the most recent readings are always preserved). You can read the contents of memory at any time, even during a scan. Reading memory *is not* cleared when you read it.
- Each time you start a new scan, the instrument clears all readings (including alarm data) stored in reading memory from the previous scan. Therefore, the contents of memory are always from the most recent scan.
- While a scan is running, the instrument automatically stores the minimum and maximum readings and calculates the average for each channel. You can read these values at any time, even during a scan.
- Mx+B scaling and alarm limits are applied to measurements during a scan and all data is stored in non-volatile memory. You can read the contents of reading memory or the alarm queue at any time, even during a scan.
- In the Monitor function, the instrument takes readings as often as it can on a single channel, even during a scan (*see Single-Channel Monitoring on page 171*). This feature is useful for troubleshooting your system before a test or for watching an important signal.
- If you abort a scan that is running, the instrument will complete the one measurement in progress (the entire scan will not be completed) and the scan will stop. You cannot resume the scan from where it left off. If you initiate a new scan, all readings are cleared from memory.
- When you add a multiplexer channel to a scan list, that entire module is dedicated to the scan. The instrument issues a Card Reset to open all channels on that module. You cannot perform low-level close or open operations on any channels on that module (even those channels that are not configured).

### Scanning

- While a scan is running, you can perform some low-level control operations on modules that do not contain channels in the scan list. For example, you can open or close channels or issue a Card Reset on switching modules that do not contain channels in the scan list. However, you cannot change any parameters that affect the scan (channel configuration, scan interval, scaling values, alarm limits, Card Reset, etc.) while a scan is running.
- When you add a digital read (multifunction module) to a scan list, that port is dedicated to the scan. The instrument issues a Card Reset to make that port an input port (the other port is not affected).
- While a scan is running, you can perform low-level control operations on any channels on the multifunction module that are not in the scan. For example, you can output a DAC voltage or write to a digital port (even if the totalizer is part of the scan list). However, you cannot change any parameters that affect the scan (channel configuration, scan interval, Card Reset, etc.) while a scan is running.
- If a scan includes a read of the totalizer, multifunction module, the count is reset each time it is read during the scan *only* when the totalizer reset mode is enabled (TOTAlize:TYPE RRESet command or the *Advanced* menu for the totalizer).
- If you install a module while a scan is running, the instrument will cycle power and resume scanning. If you remove a module while a scan is running, the instrument will cycle power, and it will not resume scanning when the reboot completes. If you are logging to a USB drive, the instrument will not log any scans that occur between the removal of the module and the reboot of the instrument.
- You can use either the internal DMM or an external DMM to make measurements of your configured channels. However, the instrument allows only one scan list at a time; you cannot scan some channels using the internal DMM and others using an external DMM. Readings are stored in 34970A/34972A memory *only* when the internal DMM is used.
- If the internal DMM is installed and enabled, the instrument will automatically use it for scanning. For externally-controlled scans, you must either remove the internal DMM from the 34970A/34972A or disable it (see “*Internal DMM Disable*” on page 145).

## Power Failure

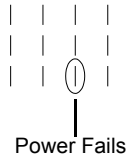





- When shipped from the factory, the instrument is configured to automatically recall the power-down state when power is restored. In this configuration, the instrument will automatically recall the instrument state at power-down and resume a scan in progress. If you do not want the power-down state to be recalled when power is restored, send the `MEMory:STATe:RECall:AUTO OFF` command (also see the *Utility* menu); a Factory Reset (`*RST` command) is then issued when power is restored.
- If the instrument is in the middle of a scan sweep when power fails, all readings from that partially completed sweep will be discarded (a *sweep* is one pass through the scan list). For example, assume that your scan list includes four multiplexer channels and you want to sweep through the scan list three times (see diagram). A power failure occurs after the second reading in the third scan sweep. The instrument will discard the last two of the 10 readings and will resume scanning at the beginning of the third scan sweep.
- If you remove a module or move a module to a different slot while power is off, the scan *will not* resume when power is restored. No error is generated.
- If you replace a module with a module of the same type while power is off, the instrument will continue scanning when power is restored. No error is generated.

## Adding Channels to a Scan List

Before you can initiate a scan, you must configure the channels to be scanned and set up a *scan list* (these two operations occur simultaneously from the front panel). The instrument automatically scans the configured channels in ascending order from slot 100 through slot 300.

### *To Build a Scan List From the Front Panel:*

To add the active channel to the scan list, press . Select the function, range, resolution, and other measurement parameters for this channel. You can also press  to sequentially step through the scan list and take a measurement on each channel (readings are not stored in memory). This is an easy way to verify your wiring connections and channel configuration (also valid during a scan).

- When you reconfigure a channel and add it to the scan list, it is important to note that the previous configuration on that channel is lost. For example, assume that a channel is configured for DC voltage measurements. When you reconfigure that channel for thermocouple measurements, the previous range, resolution, and channel delay are set to their Factory Reset (\*RST command) state.
- To remove the active channel from the scan list, press  and select CHANNEL OFF. If you decide to add that channel back to the scan list with the same function, the original channel configuration (including scaling and alarm values) is still present.
- To initiate a scan and store all readings in memory, press  (the **SCAN** annunciator will turn on). Each time you initiate a new scan, the instrument clears all previously stored readings.
- To stop a scan, press and hold .

***To Build a Scan List From the Remote Interface:*** •

- The MEASure?, CONFIgure, and ROUTe:SCAN commands contain a *scan\_list* parameter which defines the list of channels in the scan list. Note that each time you send one of these commands, it redefines the scan list. To determine which channels are currently in the scan list, you can send the ROUTe:SCAN? query command.
- To initiate a scan, execute the MEASure?, READ?, or INITiate command. The MEASure? and READ? commands send readings directly to the instrument's output buffer but readings *are not* stored in memory. The INITiate command stores readings in memory. Use the FETCh? command to retrieve stored readings from memory.

*See the Agilent 34970A/34972A Programmer's Reference Help for more information on using these commands.*

- When you reconfigure a channel and add it to the scan list using MEASure? or CONFIgure, it is important to note that the previous configuration on that channel is lost. For example, assume that a channel is configured for DC voltage measurements. When you reconfigure that channel for thermocouple measurements, the previous range, resolution, and channel delay are set to their Factory Reset (\*RST command) state.
- Each time you initiate a new scan, the instrument clears all previously stored readings.
- To stop a scan, execute the ABORT command.

**Scanning****Scan Interval**

You can configure the event or action that controls the onset of each sweep through the scan list (a *sweep* is one pass through the scan list):

- You can set the instrument's internal timer to automatically scan at a specific interval. You can also program a time delay between channels in the scan list.
- You can manually control a scan by repeatedly pressing  from the front panel.
- You can start a scan by sending a software command from the remote interface (MEASure? or INITiate command).
- You can start a scan when an external TTL trigger pulse is received.
- You can start a scan when an alarm event is logged on the channel being monitored.

**Interval Scanning** In this configuration, you control the frequency of scan sweeps by selecting a wait period from the start of one sweep to the start of the next sweep (called the *scan-to-scan interval*). The countdown time is shown on the front-panel display between one scan sweep and the start of the next sweep. If the scan interval is less than the time required to measure all channels in the scan list, the instrument will scan continuously, as fast as possible (no error is generated).

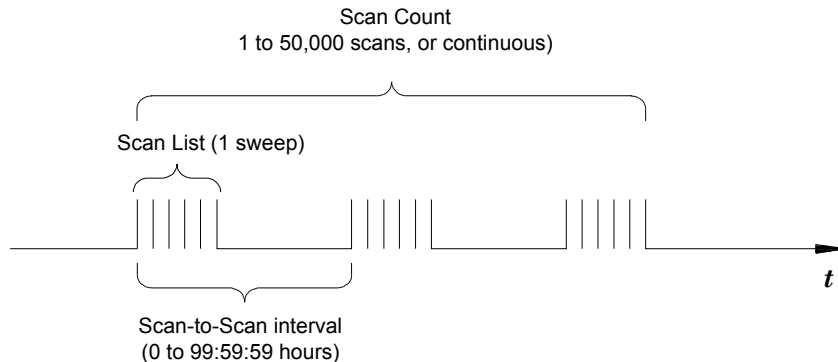



- You can set the scan interval to any value between 0 seconds and 99:59:59 hours (359,999 seconds), with 1 ms resolution.
- Once you have initiated the scan, the instrument will continue scanning until you stop it or until the scan count is reached. See “Scan Count” on page 102 for more information.
- Mx+B scaling and alarm limits are applied to measurements during a scan and all data is stored in non-volatile memory.
- The MEASure? and CONFigure commands automatically set the scan interval to immediate (0 seconds) and the scan count to 1 sweep.
- From the front panel, a Factory Reset (Sto/Rcl menu) sets the scan interval to 10 seconds and the scan count to continuous. From the remote interface, a Factory Reset (\*RST command) sets the scan interval to immediate (0 seconds) and the scan count to 1 sweep.
- *Front-Panel Operation:* To select interval scanning and set a scan interval time (hour:minutes:seconds), choose the following item.

 INTERVAL SCAN

To initiate the scan and store all readings in memory, press  (the **SCAN** annunciator will turn on). Between scan sweeps, the count-down time is shown on the front-panel (00:04 TO SCAN).

**Note:** To stop a scan, press and hold .

- *Remote Interface Operation:* The following program segment configures the instrument for an interval scan.

```
TRIG:SOURCE TIMER      Select the interval timer configuration
TRIG:TIMER 5           Set the scan interval to 5 seconds
TRIG:COUNT 2         Sweep the scan list 2 times
INIT                   Initiate the scan
```

**Note:** To stop a scan, send the ABORT command.

**Scanning**

**Scan Once** In this configuration, the instrument waits for either a front-panel key press or a remote interface command before sweeping through the scan list.

- All readings from the scan are stored in non-volatile memory. Readings accumulate in memory until the scan is terminated (until the scan count is reached or until you abort the scan).
- You can specify a scan count which sets the number of front-panel key presses or scan trigger commands that will be accepted before terminating the scan. See “Scan Count” on page 102 for more information.
- Mx+B scaling and alarm limits are applied to measurements during a Scan Once operation and all data is stored in non-volatile memory.
- *Front-Panel Operation:*

 MANUAL SCAN

To initiate the scan and store all readings in memory, press . The **ONCE** annunciator turns on as a reminder that a Scan Once operation is in progress.

**Note:** To stop a scan, press and hold .

- *Remote Interface Operation:* The following program segment configures the instrument for a Scan Once operation.

```
TRIG:SOURCE BUS      Select the bus (once) configuration
TRIG:COUNT 2       Sweep the scan list 2 times
INIT                 Initiate the scan
```

Then, send the \*TRG (trigger) command to begin each scan sweep. You can also trigger the instrument from the GPIB interface by sending the IEEE-488 Group Execute Trigger (GET) message. The following statement shows how to send a GET message.

```
TRIGGER 709          Group Execute Trigger
```

**Note:** To stop a scan, send the ABORT command.

**External Scanning** In this configuration, the instrument sweeps through the scan list once each time a low-going TTL pulse is received on the rear-panel *Ext Trig Input* line (pin 6).

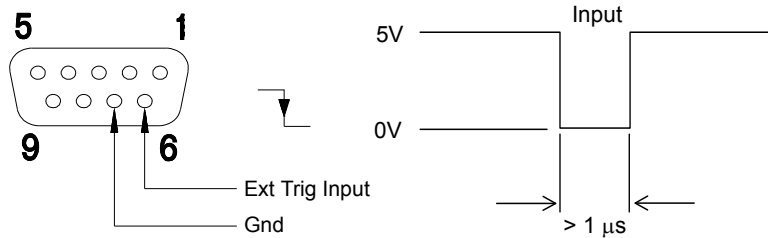

**Ext Trig Connector**

- You can specify a scan count which sets the number of external pulses the instrument will accept before terminating the scan. See “Scan Count” on page 102 for more information.
- If the instrument receives an external trigger before it is ready to accept one, it will buffer one trigger before generating an error.
- All readings from the scan are stored in non-volatile memory. Readings accumulate in memory until the scan is terminated (until the scan count is reached or until you abort the scan).
- Mx+B scaling and alarm limits are applied to measurements during the scan and all data is stored in non-volatile memory.
- *Front-Panel Operation:*

**Interval** EXTERNAL SCAN

To initiate the scan, press **Scan**. The **EXT** annunciator turns on as a reminder that an External Scan is in progress. When a TTL pulse is received, the scan starts and readings are stored in memory. To stop scan, press and hold **Scan**.

## Scanning

- *Remote Interface Operation:* The following program segment configures the instrument for an External Scan.

```
TRIG:SOURCE EXT      Select the external trigger configuration
TRIG:COUNT 2       Sweep the scan list 2 times
INIT                 Initiate the scan
```

**Note:** To stop a scan, send the `ABORT` command.



**Scanning on Alarm** In this configuration, the instrument sweeps the scan list once each time a reading crossing an alarm limit on a channel. You can also assign alarms to channels on the multifunction module. For example, you can generate an alarm when a specific bit pattern is detected or when a specific count is reached.

**Note:** For complete details on configuring and using alarms, refer to “Alarm Limits” starting on page 139.

- In this scan configuration, you may use the Monitor function to continuously take readings on a selected channel and wait for an alarm on that channel. The monitored channel can be part of the scan list but you can also use a channel on the multifunction module (which does not have to be part of the scan list and you do not have to use the Monitor function). For example, you can generate an alarm on a totalizer channel which will initiate a scan when a specific count is reached.
- You can specify a scan count which sets the number of alarms that will be allowed before terminating the scan. See “Scan Count” on page 102 for more information.
- All readings from the scan are stored in non-volatile memory. Readings accumulate in memory until the scan is terminated (until the scan count is reached or until you abort the scan).
- Mx+B scaling and alarm limits are applied to measurements during the scan and all data is stored in non-volatile memory.

- *Front-Panel Operation:*

 SCAN ON ALARM

To enable the Monitor function select the desired channel and then press . To initiate the scan, press . When an alarm event occurs, the scan starts and readings are stored in memory.

**Note:** To stop a scan, press and hold .

- *Remote Interface Operation:* The following program segment configures the instrument to scan when an alarm occurs.

TRIG:SOURCE ALARM1	<i>Select the alarm configuration</i>
TRIG:COUNT 2	<i>Sweep the scan list 2 times</i>
CALC:LIM:UPPER 5, (@103)	<i>Set the upper limit</i>
CALC:LIM:UPPER:STATE ON, (@103)	<i>Enable the upper limit</i>
OUTPUT:ALARM1:SOURCE (@103)	<i>Report alarms on Alarm 1</i>
ROUT:MON (@103)	<i>Select monitor channel</i>
ROUT:MON:STATE ON	<i>Enable monitoring</i>
INIT	<i>Initiate the scan</i>

**Note:** To stop a scan, send the `ABORT` command.

## Scanning

### Scan Count

You can specify the number of times the instrument will sweep through the scan list. When the specified number of sweeps have occurred, the scan stops.

- Select a scan count between 1 to 50,000 scan sweeps, or continuous.
- During an Interval Scan (*see page 96*), the scan count sets the number of times the instrument will sweep through the scan list and therefore determines the overall duration of the scan.
- During a Scan Once operation (*see page 98*), the scan count sets the number of front-panel key presses or scan trigger commands that will be accepted before terminating the scan.
- During an External Scan (*see page 99*), the scan count sets the number of external trigger pulses that will be accepted before terminating the scan.
- During an Alarm Scan (*see page 100*), the scan count sets the number of alarms that will be allowed before terminating the scan.
- You can store up to 50,000 readings in non-volatile memory during a scan. If you set a continuous scan and memory overflows (the **MEM** annunciator will turn on), a status register bit is set and new readings will overwrite the first readings stored (the most recent readings are always preserved).
- The MEASure? and CONFigure commands automatically set the scan count to 1.
- From the front panel, a Factory Reset (*Sto/Rcl* menu) sets the scan count to continuous. From the remote interface, a Factory Reset (\*RST command) sets the scan count to 1 sweep.

- *Front-Panel Operation:*

 00020 SCANS

The default is CONTINUOUS. To set the count to a value between 1 and 50,000 scans, turn the knob clockwise and enter a number.

- *Remote Interface Operation:*

TRIG:COUNT 20

**Note:** To configure a continuous scan, send TRIG:COUNT INFINITY.

**Scanning****Reading Format**

During a scan, the instrument automatically adds a time stamp to all readings and stores them in non-volatile memory. Each reading is stored with measurement units, time stamp, channel number, and alarm status information. From the remote interface, you can specify which information you want returned with the readings (from the front panel, all of the information is available for viewing). The reading format applies to all readings being removed from the instrument from a scan; you cannot set the format on a per-channel basis.

- From the remote interface, the time stamp information is returned either in absolute time (time of day with date) or relative time (time since start of scan). Use the `FORMat:READ:TIME:TYPE` command to select absolute or relative time. From the front panel, the time stamp is always returned in absolute time.
- The `MEASure?` and `CONFigure` commands automatically turn off the units, time, channel, and alarm information.
- A Factory Reset (`*RST` command) turns off the units, time, channel, and alarm information.
- *Remote Interface Operation:* The following commands select the format of readings returned from a scan.

```
FORMat:READing:ALARm ON
FORMat:READing:CHANnel ON
FORMat:READing:TIME ON
FORMat:READing:TIME:TYPE {ABSolute|RELative}
FORMat:READing:UNIT ON
```

The following is an example of a reading stored in memory with all fields enabled (relative time is shown).

2.61950000E+01 C, 00000000.017, 101, 2

- 
- |   |   |
|---|---|
| <b>1</b> Reading with Units (26.195 °C)   | <b>3</b> Channel Number   |
| <b>2</b> Time Since Start of Scan (17 ms) | <b>4</b> Alarm Limit Threshold Crossed<br>0 = No Alarm, 1 = LO, 2 = HI) |



## Channel Delay

You can control the pace of a scan sweep by inserting a delay between multiplexer channels in the scan list (useful for high-impedance or high-capacitance circuits). The delay is inserted between the relay closure and the actual measurement on the channel. The programmed channel delay overrides the default channel delay that the instrument automatically adds to each channel.

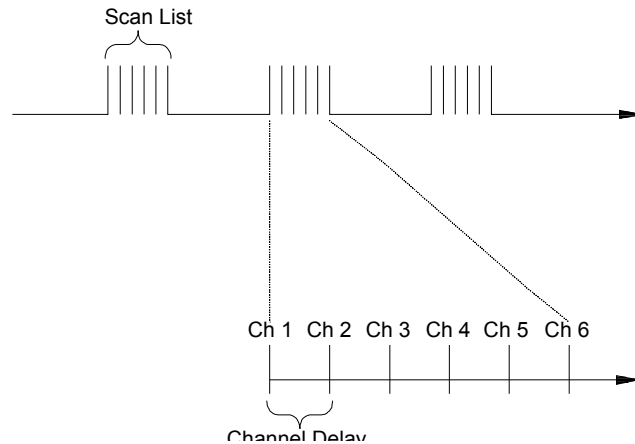

- You can set the channel delay to any value between 0 seconds and 60 seconds, with 1 ms resolution. You can select a different delay for each channel. The default channel delay is automatic; the instrument determines the delay based on function, range, integration time, and AC filter setting (see “Automatic Channel Delays” on the next page).
- The MEASure? and CONFigure commands set the channel delay to automatic. A Factory Reset (\*RST command) also sets the channel delay to automatic.

• *Front-Panel Operation:*

Advanced CH DELAY TIME

- *Remote Interface Operation:* The following command adds a 2-second channel delay to channel 101.

```
ROUT:CHAN:DELAY 2, (@101)
```

**Scanning****Automatic Channel Delays**

If you do not specify a channel delay, the instrument selects a delay for you. The delay is determined by function, range, integration time, and AC filter setting as shown below.

**DC Voltage, Thermocouple, DC Current (for all ranges):**

Integration Time	Channel Delay
PLC > 1	2.0 ms
PLC ≤ 1	1.0 ms

**Resistance, RTD, Thermistor (2- and 4-wire):**

Range	Channel Delay (For PLC > 1)	Range	Channel Delay For PLC ≤ 1)
100Ω	2.0 ms	100Ω	1.0 ms
1 kΩ	2.0 ms	1 kΩ	1.0 ms
10 kΩ	2.0 ms	10 kΩ	1.0 ms
100 kΩ	25 ms	100 kΩ	20 ms
1 MΩ	30 ms	1 MΩ	25 ms
10 MΩ	200 ms	10 MΩ	200 ms
100MΩ	200 ms	100MΩ	200 ms

**AC Voltage, AC Current (for all ranges):**

AC Filter	Channel Delay
Slow (3 Hz)	7.0 sec
Medium (20 Hz)	1.0 sec
Fast (200 Hz)	120 ms

**Frequency, Period:**

AC Filter	Channel Delay
Slow (3 Hz)	0.6 sec
Medium (20 Hz)	0.3 sec
Fast (200 Hz)	0.1 sec

**Digital Input, Totalize**

Channel Delay
0 sec

- *Front-Panel Operation:*

 CH DELAY AUTO

- *Remote Interface Operation:* The following command enables an automatic channel delay on channel 01.

```
ROUT:CHAN:DELAY:AUTO ON, (@101)
```

Selecting a specific channel delay using the `ROUTE:CHANnel:DELay` command disables the automatic channel delay.



## Viewing Readings Stored in Memory

During a scan, the instrument automatically adds a time stamp to all readings and stores them in non-volatile memory. Readings are stored only during a scan. You can read the contents of memory at any time, even during a scan.





- You can store up to 50,000 readings in non-volatile memory during a scan. From the front panel, you can view the last 100 readings and all of the readings are available from the remote interface. If memory overflows (the **MEM** annunciator will turn on), a status register bit is set and new readings will overwrite the first readings stored (the most recent readings are always preserved).
- Each time you start a new scan, the instrument clears all readings (including alarm data) stored in reading memory from the previous scan. Therefore, the contents of memory are always from the most recent scan.
- The instrument clears all readings in memory after a Factory Reset (`*RST` command) or Instrument Preset (`SYSTEM:PRESet` command). Reading memory *is not* cleared when you read it.

### Scanning

- While a scan is running, the instrument automatically stores the minimum and maximum readings and calculates the average for each channel. You can read these values at any time, even during a scan.
- Each reading is stored with measurement units, time stamp, channel number, and alarm status information. From the remote interface, you can specify which information you want returned with the readings (from the front panel, all of the information is available for viewing). For more information, see “*Reading Format*” on page 104.
- Readings acquired during a Monitor are *not stored* in memory (however, all readings from a scan in progress at the same time are stored in memory).
- The MEASure? and READ? commands send readings directly to the instrument’s output buffer but readings *are not* stored in memory. You will not be able to view these readings.
- The INITiate command stores readings in memory. Use the FETCh? command to retrieve stored readings from memory (the readings are not erased when you read them).

- Front-Panel Operation:* From the front panel, data is available for the last 100 readings on each channel readings taken during a scan (all of the data is available from the remote interface). After turning the knob to the desired channel, press the  and  keys to choose the data that you want to view for the selected channel as shown below (the **LAST**, **MIN**, **MAX**, and **AVG** annunciators turn on to indicate what data is currently being viewed). Reading memory *is not* cleared when you read it. Note that you can view readings from the front panel even while the instrument is in remote.

 READINGS

	 and 
Select Channel	Last Reading on Channel Time of Last Reading Minimum Reading on Channel Time of Minimum Reading Maximum Reading on Channel Time of Maximum Reading Average of Readings on Channel Second Most Recent Reading on Channel Third Most Recent Reading on Channel ⋮  99th Most Recent Reading on Channel

## Scanning

- *Remote Interface Operation:* The following command retrieves stored readings from memory (the readings are not erased).

```
FETCH?
```

Use the following commands to query the statistics on the readings stored in memory for a specific channel. These commands do not remove the data from memory.

```
CALC: AVER: MIN? (@305)      Minimum reading on channel  
CALC: AVER: MIN: TIME? (@305) Time minimum was logged
```

```
CALC: AVER: MAX? (@305)      Maximum reading on channel  
CALC: AVER: MAX: TIME? (@305) Time maximum was logged
```

```
CALC: AVER: AVER? (@305)     Average of all readings on channel
```

```
CALC: AVER: COUNT? (@305)    Number of readings taken on channel
```

```
CALC: AVER: PTPEAK? (@305)   Peak-to-peak (maximum-minimum)
```

The following command retrieves the last reading taken on channel 301 during a scan.

```
DATA: LAST? (@301)
```

The following command clears the contents of statistics memory for the selected channel.

```
CALC: AVER: CLEAR (@305)
```

Use the following command to determine the total number of readings stored in memory (all channels) from the most recent scan.

```
DATA: POINTS?
```

The following command reads and clears the specified number of readings from memory. This allows you to continue a scan without losing data stored in memory (if memory becomes full, new readings will overwrite the first readings stored). The specified number of readings are cleared from memory, starting with the oldest reading.

```
DATA: REMOVE? 12
```

---

## Scanning with External Instruments

If your application doesn't require the built-in measurement capabilities of the 34970A/34972A, you can order it without the internal DMM. In this configuration, you can use the 34970A/34972A for signal routing or control applications. If you install a multiplexer plug-in module, you can use the 34970A/34972A for scanning with an external instrument. You can connect an external instrument (such as a DMM) to the multiplexer COM terminal.

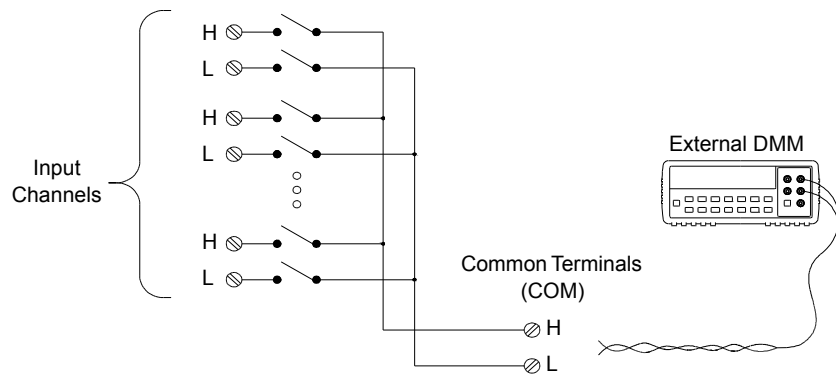

## Chapter 4 Features and Functions

### Scanning with External Instruments

To control scanning with an external instrument, two control lines are provided. When the 34970A/34972A and the external instrument are properly configured, you can synchronize a scan sequence between the two.

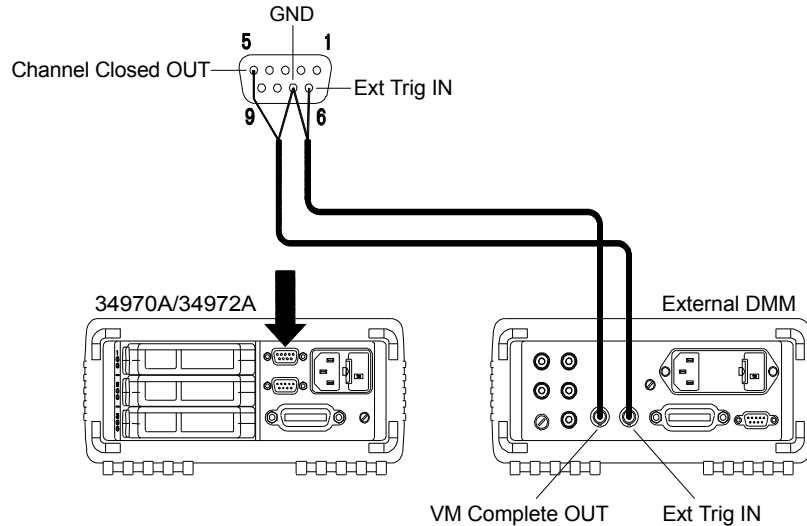

In this configuration, you must set up a *scan list* to include all desired multiplexer or digital channels. Channels which are not in the list are skipped during the scan. The instrument automatically scans the list of channels in ascending order from slot 100 through slot 300.

For an externally-controlled scan, you must either remove the internal DMM from the 34970A/34972A or disable it (see “*Internal DMM Disable*” on page 167). Since the internal DMM is not used, readings from multiplexer channels are *not stored* in internal reading memory.

External connections are required to synchronize the scan sequence between the 34970A/34972A and the external instrument. The 34970A/34972A must notify the external instrument when a relay is closed and settled (including channel delay). The 34970A/34972A outputs a *Channel Closed* pulse from pin 5 on the rear-panel connector (see *previous page*). In response, the external instrument must notify the 34970A/34972A when it has finished its measurement and is ready to advance to the next channel in the scan list. The 34970A/34972A accepts a *Channel Advance* signal on the *External Trigger* input line (pin 6).



- You can configure the event or action that controls the onset of each sweep through the scan list (a *sweep* is one pass through the scan list). When the internal DMM is removed (or disabled), the default scan interval source is “timer.” *For more information, refer to “Scan Interval” on page 80.*
- You can configure the event or action that notifies the 34970A/34972A to advance to the next channel in the scan list. Note that the *Channel Advance* source shares the same sources as the scan interval. However, an error is generated if you attempt to set the channel advance source to the same source used for the scan interval.
- You can specify the number of times the instrument will sweep through the scan list. When the specified number of sweeps have occurred, the scan stops. *For more information, refer to “Scan Count” on page 102.*
- An externally-controlled scan can also include a read of a digital port or a read of the totalizer count on the multifunction module. When the channel advance reaches the first digital channel, the instrument scans through all of the digital channels in that slot and stores the readings in reading memory (only one channel advance signal is required).
- You can configure the list of channels for 4-wire external scanning without the internal DMM. When enabled, the instrument automatically pairs channel  $n$  with channel  $n+10$  (34901A) or  $n+8$  (34902A) to provide the source and sense connections.
- *Front-Panel Operation:* To select the channel advance source, choose from the following items.

 AUTO ADVANCE , EXT ADVANCE

To initiate the scan, press  (the **SCAN** annunciator will turn on).

To configure the instrument for 4-wire external scanning, choose the following item.

 4W SCAN

## Chapter 4 Features and Functions

### Scanning with External Instruments

- *Remote Interface Operation:* The following program segment configures the instrument for an externally controlled scan.

TRIG:SOUR TIMER	<i>Select the scan interval</i>
ROUT:CHAN:ADV:SOUR EXT	<i>Select the channel advance source</i>
TRIG:TIMER 5	<i>Set the scan interval to 5 seconds</i>
TRIG:COUNT 2	<i>Sweep the scan list 2 times</i>
INIT	<i>Initiate the scan</i>

To configure the instrument for 4-wire external scanning, send the following command.

```
ROUTe:CHANnel:FWIRE {OFF|ON}[, (@<ch_list>)]
```

---

## General Measurement Configuration

This section contains general information to help you configure the instrument for making measurements during a scan. Since these parameters are used by several measurement functions, the discussion is combined into one common section. Refer to the later sections in this chapter for more information on parameters that are specific to a particular measurement function.

***Note:** It is important that you select the measurement function before selecting other parameters on a given channel. When you change the function on a channel, all other settings (range, resolution, etc.) are reset to their default values.*

### Measurement Range

You can allow the instrument to automatically select the measurement range using *autoranging* or you can select a fixed range using *manual ranging*. Autoranging is convenient because the instrument decides which range to use for each measurement based on the input signal. For fastest scanning operation, use manual ranging on each measurement (some additional time is required for autoranging since the instrument has to make a range selection).

- Autorange thresholds:
  - Down range at <10% of range
  - Up range at >120% of range
- If the input signal is greater than can be measured on the selected range, the instrument gives an *overload indication*: “±OVL” from the front panel or “±9.9000000E+37” from the remote interface.
- For a complete list of the measurement ranges available for each function, refer to the instrument specifications in chapter 8.
- For temperature measurements, the instrument internally selects the range; you cannot select which range is used. For thermocouple measurements, the instrument internally selects the 100 mV range. For thermistor and RTD measurements, the instrument autoranges to the correct range for the transducer resistance measurement.

- For frequency and period measurements, the "range" parameter is used to compute a specific measurement resolution (*see the Agilent 34970A/34972A Programmer's Reference Help for details*). When specifying a (non-default) resolution, both the range and resolution parameters must be specified within the MEASure? and CONFIgure commands. *Refer to the Agilent 34970A/34972A Programmer's Reference Help for more information.*
- The MEASure? and CONFIgure commands contain an optional range parameter which allows you to specify the range or autoranging.
- The instrument returns to autoranging when the measurement function is changed and after a Factory Reset (\*RST command). An Instrument Preset (SYSTem:PRESet command) or Card Reset (SYSTem:CPON command) *does not* change the range setting.
- *Front-Panel Operation:* First, select the measurement function on the active channel. You are automatically guided to the next level of the menu where you can select a specific range or autorange.

 100 mV RANGE

- *Remote Interface Operation:* You can select the range using parameters in the MEASure? and CONFIgure commands. For example, the following statement selects the 10 VDC range on channel 301.

```
CONF:VOLT:DC 10,DEF, (@301)
```

## Measurement Resolution

Resolution is expressed in terms of *number of digits* the instrument can measure or display on the front panel. You can set the resolution to 4, 5, or 6 *full digits*, plus a “½” digit which can only be a “0” or “1”. To increase your measurement accuracy and improve noise rejection, select 6½ digits. To increase your measurement speed, select 4½ digits.

10.216,5 VDC

**This is the 10 VDC range, 5½ digits are displayed.**

-045.23 mVDC

**This is the 100 mVDC range, 4½ digits are displayed.**

113.325,6 OHM

**This is the 100 ohm range, 6½ digits are displayed.**

- For temperature measurements taken from the remote interface, the resolution is fixed at 6½ digits. From the front panel, you can set the resolution in terms of the number of digits displayed past the decimal point (*Measure* menu).
- For AC voltage measurements, the resolution is fixed at 6½ digits. The only way to control the reading rate for AC measurements is by changing the channel delay (*see page 105*) or by setting the AC filter to the highest frequency limit (*see page 131*).

- The specified resolution is used for all measurements on the selected channel. If you have applied Mx+B scaling or have assigned alarms to the selected channel, those measurements are also made using the specified resolution. Measurements taken during the Monitor function also use the specified resolution.
- Changing the number of digits does more than just change the resolution of the instrument. It also changes the *integration time*, which is the period the instrument's analog-to-digital (A/D) converter samples the input signal for a measurement. See *Custom A/D Integration Time*, on page 120 for more information.
- The MEASure? and CONFigure commands contain an optional resolution parameter which allows you to specify the resolution.
- The instrument returns to 5½ digits when the measurement function is changed and after a Factory Reset (\*RST command). An Instrument Preset (SYSTem:PRESet command) or Card Reset (SYSTem:CPON command) *does not* change the resolution setting.
- *Front-Panel Operation*: First, select the measurement function on the active channel. You are automatically guided to the next level of the menu where you can select the number of digits. *The default is 5½ digits.*

 6 1/2 DIGITS

For temperature measurements, go to the menu and select the number of digits displayed past the decimal point on the selected channel.

 DISPLAY 1 °C

- *Remote Interface Operation:* Specify the resolution in the same units as the measurement function, *not in number of digits*. For example, if the function is DC volts, specify the resolution in volts. For frequency, specify the resolution in hertz.

You can select the resolution using parameters in the MEASure? and CONFigure commands. For example, the following statement selects the 10 VDC range with 4½ digits of resolution on channel 301.

```
CONF:VOLT:DC 10,0.001, (@301)
```

The following statement selects the 1 A range with 6½ digits of resolution on channel 221.

```
MEAS:CURR:AC? 1,1E-6, (@221)
```

- You can also select the resolution using the SENSEe commands. For example, the following statement specifies a 4-wire ohms measurement with 100Ω of resolution on channel 103.

```
SENS:FRES:RES 100, (@103)
```

## Custom A/D Integration Time

Integration time is the period of time that the instrument's analog-to-digital (A/D) converter samples the input signal for a measurement. Integration time affects the measurement resolution (for better resolution, use a longer integration time) and measurement speed (for faster measurements, use a shorter integration time).

- Integration time is specified in number of power line cycles (PLCs). Select from 0.02, 0.2, **1**, 2, 10, 20, 100, or 200 power line cycles.  
*The default is 1 PLC.*
- Only the integral number of power line cycles (1, 2, 10, 20, 100, or 200 PLCs) provide normal mode (line frequency noise) rejection.
- You can also specify integration time directly in seconds (this is called *aperture time*). Select a value between 400  $\mu$ s and 4 seconds, with 10  $\mu$ s resolution.
- The only way to control the reading rate for AC measurements is by changing the channel delay (*see page 105*) or by setting the AC filter to the highest frequency limit (*see page 131*).
- The specified integration time is used for all measurements on the selected channel. If you have applied Mx+B scaling or have assigned alarms to the selected channel, those measurements are also made using the specified integration time. Measurements taken during the Monitor function also use the specified integration time.
- The following table shows the relationship between integration time, measurement resolution, number of digits, and number of bits.

Integration Time	Resolution	Digits	Bits
0.02 PLC	<0.0001 x Range	4½ Digits	15
0.2 PLC	<0.00001 x Range	5½ Digits	18
<b>1 PLC</b>	<b>&lt;0.000003 x Range</b>	<b>5½ Digits</b>	<b>20</b>
2 PLC	<0.0000022 x Range	6½ Digits	21
<b>10 PLC</b>	<b>&lt;0.000001 x Range</b>	<b>6½ Digits</b>	<b>24</b>
20 PLC	<0.0000008 x Range	6½ Digits	25
100 PLC	<0.0000003 x Range	6½ Digits	26
200 PLC	<0.00000022 x Range	6½ Digits	26



- The instrument selects 1 PLC when the measurement function is changed and after a Factory Reset (\*RST command). An Instrument Preset (SYSTEM:PRESet command) or Card Reset (SYSTEM:CPON command) *does not* change the integration time setting.
- *Front-Panel Operation:* First, select the measurement function on the active channel. Then, go to the *Advanced* menu and select one of the choices in PLCs for the active channel.

 INTEG 2 PLC

To select the aperture time, select INTEGRATE T from the *Advanced* menu and then specify a value in seconds for the active channel.

 INTEGRATE T

- *Remote Interface Operation:* You can set the integration time using the SENSE commands. For example, the following statement specifies an integration time of 10 PLC for DC voltage measurements on channel 301.

```
SENS:VOLT:DC:NPLC 10, (@301)
```

You can also select an aperture time using the SENSE commands. For example, the following statement specifies an aperture time of 2 ms for resistance measurements on channel 104.

```
SENS:RES:APER 0.002, (@104)
```

## Autozero

When autozero is *enabled* (default), the instrument internally disconnects the input signal following each measurement, and takes a *zero reading*. It then subtracts the zero reading from the preceding reading. This prevents offset voltages present on the instrument's input circuitry from affecting measurement accuracy.

When autozero is *disabled*, the instrument takes one zero reading and subtracts it from all subsequent measurements. It takes a new zero reading each time you change the function, range, or integration time.

- Applies to temperature, DC voltage, 2-wire ohms, and DC current measurements only. Autozero is enabled when you select 4-wire ohms measurements.
- The autozero mode is set indirectly when you set the resolution and integration time. Autozero is automatically turned off when you select an integration time less than 1 PLC.
- You can set autozero from the remote interface only; you cannot directly set autozero from the front panel.
- The autozero setting is stored in *non-volatile* memory, and *does not* change when power has been off, after a Factory Reset (\*RST command), or after an Instrument Preset (SYSTEM:PRESet command).
- *Remote Interface Operation:* The OFF and ONCE parameters have a similar effect. Autozero OFF *does not* issue a new zero measurement. Autozero ONCE issues an immediate zero measurement.

```
ZERO:AUTO {OFF|ONCE|ON} [, (@<ch_list>)]
```

## Temperature Measurement Configuration

This section contains information to help you configure the instrument for making temperature measurements. For more information on the types of temperature transducers, see “*Temperature Measurements*” starting on page 267.

The instrument supports direct measurement of thermocouples, RTDs, and thermistors. The instrument supports the following specific types of transducers in each category:

Thermocouples Supported	RTDs Supported	Thermistors Supported
B, E, J, K, N, R, S, T	$R_0 = 49\Omega$ to 2.1 k $\Omega$ $\alpha = 0.00385$ (DIN/IEC 751) $\alpha = 0.00391$	2.2 k $\Omega$ , 5 k $\Omega$ , 10 k $\Omega$ , 44000 Series



### Measurement Units

- The instrument can report temperature measurements in °C (Celsius), °F (Fahrenheit), or K (Kelvin). You can mix temperature units on different channels within the instrument and on the same module.
- The instrument selects Celsius when the probe type is changed and after a Factory Reset (\*RST command). An Instrument Preset (SYSTEM:PRESet command) or Card Reset (SYSTEM:CPON command) *does not* change the units setting.
- Setting the Mx+B measurement label to °C, °F, or K has *no effect* on the temperature measurement units currently selected.
- *Front-Panel Operation:* First, select the temperature function on the active channel. Then, select the temperature units.

 UNITS °F

- *Remote Interface Operation:*

UNIT:TEMP F, (@103)

## **Thermocouple Measurements**

*To connect a thermocouple to the module's screw terminals, see page 28.*

- The instrument supports the following thermocouple types: B, E, J, K, N, R, S, and T using ITS-90 software conversions. *The default is a J-Type thermocouple.*
- Thermocouple measurements require a reference junction temperature. For the reference junction temperature, you can use an internal measurement on the module, an external thermistor or RTD measurement, or a known fixed junction temperature.
- If you select an external reference, the instrument automatically reserves channel 01 on the multiplexer in the *lowest* slot as the reference channel (thermistor or RTD measurement). If you have more than one multiplexer installed, channel 01 on the module in the lowest slot is used as the reference for the entire instrument.
- Before configuring a thermocouple channel with an external reference, you must configure the reference channel (channel 01) for a thermistor or RTD measurement. An error is generated if you attempt to select the external reference source before configuring the reference channel. An error is also generated if you change the function on the reference channel after selecting the external reference for a thermocouple channel.
- If you select a fixed reference temperature, specify a value between -20 °C and +80 °C (always specify the temperature in °C regardless of the temperature units currently selected).
- The accuracy of the measurement is highly dependent upon the thermocouple connections and the type of reference junction used. Use a fixed temperature reference for the highest accuracy measurements. The internal isothermal block reference provides the lowest accuracy measurements. For more information on reference junction temperature measurements and associated errors, see the sections on pages 267 and 274.

- The *thermocouple check* feature allows you to verify that your thermocouples are properly connected to the screw terminals for measurements. If you enable this feature, the instrument measures the channel resistance after each thermocouple measurement to ensure a proper connection. If an open connection is detected (greater than 5 k $\Omega$  on the 10 k $\Omega$  range), the instrument reports an overload condition for that channel (or displays "OPEN T/C" on the front panel).
- *Front-Panel Operation:* To select the thermocouple function on the active channel, choose the following items.

 TEMPERATURE , THERMOCOUPLE

To select the thermocouple type for the active channel, choose the following item.

 J TYPE T/C

To enable the thermocouple check feature on the active channel (opens are reported as "OPEN T/C"), choose the following item.

 T/C CHECK ON

To select the reference junction source for the active channel, choose one of the following items.

 INTERNAL REF , EXTERNAL REF , FIXED REF

**Note:** Before selecting an external source, be sure to configure channel 01 in the lowest slot for a thermistor or RTD measurement.

## Chapter 4 Features and Functions

### Temperature Measurement Configuration

- *Remote Interface Operation:* You can use the MEASure? or CONFigure command to select the probe type and thermocouple type. For example, the following statement configures channel 301 for a J-type thermocouple measurement.

```
CONF:TEMP TC,J, (@301)
```

You can also use the SENSE command to select the probe type and thermocouple type. For example, the following statement configures channel 203 for a J-type thermocouple measurement.

```
SENS:TEMP:TRAN:TC:TYPE J, (@203)
```

The following statements use the SENSE command to set a fixed reference junction temperature of 40 degrees (always in °C) on channel 203.

```
SENS:TEMP:TRAN:TC:RJUN:TYPE FIXED, (@203)  
SENS:TEMP:TRAN:TC:RJUN 40, (@203)
```

The following statement enables the thermocouple check feature on the specified channels (opens are reported as “+9.90000000E+37”).

```
SENS:TEMP:TRAN:TC:CHECK ON, (@203,301)
```

## RTD Measurements

To connect an RTD to the module's screw terminals, see page 28.

- The instrument supports RTDs with  $\alpha = 0.00385$  (DIN / IEC 751) using ITS-90 software conversions or  $\alpha = 0.00391$  using IPTS-68 software conversions. *The default is  $\alpha = 0.00385$ .*
- The resistance of an RTD is nominal at 0 °C and is referred to as  $R_0$ . The instrument can measure RTDs with  $R_0$  values from 49 $\Omega$  to 2.1 k $\Omega$ . *The default is  $R_0 = 100\Omega$ .*
- “PT100” is a special label that is sometimes used to refer to an RTD with  $\alpha = 0.00385$  and  $R_0 = 100\Omega$ .
- You can measure RTDs using a 2-wire or 4-wire measurement method. The 4-wire method provides the most accurate way to measure small resistances. Connection lead resistance is automatically removed using the 4-wire method.
- For 4-wire RTD measurements, the instrument automatically pairs channel  $n$  with channel  $n+10$  (34901A) or  $n+8$  (34902A) to provide the source and sense connections. For example, make the *source* connections to the HI and LO terminals on channel 2 and the *sense* connections to the HI and LO terminals on channel 12.
- *Front-Panel Operation:* To select the 2-wire or 4-wire RTD function for the active channel, choose the following items.

 TEMPERATURE , RTD , RTD 4W

To select the nominal resistance ( $R_0$ ) for the active channel, choose the following item.

  $R_0: 100.000, 0$  OHM

To select the RTD type ( $\alpha = 0.00385$  or  $0.00391$ ) for the active channel, choose the following item.

 ALPHA 0.00385

## Chapter 4 Features and Functions

### Temperature Measurement Configuration

- *Remote Interface Operation:* You can use the MEASure? or CONFigure command to select the probe type and RTD type. For example, the following statement configures channel 301 for 2-wire measurements of an RTD with  $\alpha = 0.00385$  (use “85” to specify  $\alpha = 0.00385$  or “91” to specify  $\alpha = 0.00391$ ).

```
CONF:TEMP RTD,85,(@301)
```

You can also use the SENSE command to select the probe type, RTD type, and nominal resistance. For example, the following statement configures channel 103 for 4-wire measurements of an RTD with  $\alpha = 0.00391$  (channel 103 is automatically paired with channel 113 for the 4-wire measurement).

```
SENS:TEMP:TRAN:FRTD:TYPE 91,(@103)
```

The following statement sets the nominal resistance ( $R_0$ ) to 1000 $\Omega$  on channel 103.

```
SENS:TEMP:TRAN:FRTD:RES 1000,(@103)
```



## Thermistor Measurements

To connect a thermistor to the module's screw terminals, see page 28.

- The instrument supports 2.2 k $\Omega$  (44004), 5 k $\Omega$  (44007), and 10 k $\Omega$  (44006) thermistors.
- *Front-Panel Operation:* To select the thermistor function for the active channel, choose the following items.

```
MEASure TEMPERATURE , THERMISTOR
```

To select the thermistor type for the active channel, choose from the following items.

```
TYPE 2.2 KOHM , TYPE 5 KOHM , TYPE 10 KOHM
```

- *Remote Interface Operation:* You can use the MEASure? or CONFigure command to select the probe type and thermistor type. For example, the following statement configures channel 301 for measurements of a 5 k $\Omega$  thermistor:

```
CONF:TEMP THER,5000,(@301)
```

You can also use the SENSE command to select the probe type and thermistor type. For example, the following statement configures channel 103 for measurements of a 10 k $\Omega$  thermistor:

```
SENS:TEMP:TRAN:THERM:TYPE 10000,(@103)
```

---

## Voltage Measurement Configuration

*To connect voltage sources to the module's screw terminals, see page 28.*

This section contains information to help you configure the instrument for making voltage measurements. The instrument can measure DC and true RMS ac-coupled voltages on the measurement ranges shown below.

100 mV	1V	10V	100V	300V	Autorange
--------	----	-----	------	------	-----------

### DC Input Resistance

Normally, the instrument's input resistance is fixed at 10 M $\Omega$  for all DC voltage ranges to minimize noise pickup. To reduce the effects of measurement loading errors, you can set the input resistance to greater than 10 G $\Omega$  for the 100 mVDC, 1 VDC, and 10 VDC ranges.

*Applies to DC voltage measurements only.*

Input Resistance Setting	Input Resistance 100 mV, 1V, 10 V ranges	Input Resistance 100 V, 300 V ranges
Input R Auto OFF	10 M $\Omega$	10 M $\Omega$
Input R Auto ON	> 10 G $\Omega$	10 M $\Omega$

- The instrument selects 10 M $\Omega$  (fixed input resistance on all DC voltage ranges) when the measurement function is changed or after a Factory Reset (\*RST command). An Instrument Preset (SYSTEM:PRESet command) or Card Reset (SYSTEM:CPON command) *does not* change the input resistance setting.
- *Front-Panel Operation:* First, select the DC voltage function on the active channel. Then, go to the *Advanced* menu and select 10 M $\Omega$  (fixed resistance for all DC voltage ranges) or >10 G $\Omega$ . *The default is 10 M $\Omega$ .*

 INPUT R >10 G

- *Remote Interface Operation:* You can enable or disable the automatic input resistance mode on the specified channels. With AUTO OFF (default), the input resistance is fixed at 10 MΩ for all ranges. With AUTO ON, the input resistance is set to >10 GΩ for the three lowest DC voltage ranges. The MEASure? and CONFigure commands automatically select AUTO OFF.

INPUT:IMPEDANCE:AUTO ON, (@103)

### AC Low Frequency Filter

The instrument uses three different AC filters which enable you to either optimize low frequency accuracy or achieve faster AC settling times. The instrument selects the *slow*, *medium*, or *fast* filter based on the input frequency that you specify for the selected channels.

*Applies to AC voltage and AC current measurements only.*

Input Frequency	Default Settling Delay	Minimum Settling Delay
3 Hz to 300 kHz (Slow)	7 seconds / reading	1.5 seconds
20Hz to 300 kHz (Medium)	1 second / reading	0.2 seconds
200 Hz to 300 kHz (Fast)	0.12 seconds / reading	0.02 seconds

- The instrument selects the *medium* filter (20 Hz) when the function is changed or after a Factory Reset (\*RST command). An Instrument Preset (SYSTEM:PRESet command) or Card Reset (SYSTEM:CPON command) *does not* change the setting.
- *Front-Panel Operation:* First, select the AC voltage (or AC current) function on the active channel. Then, go to the *Advanced* menu and select the slow filter (3 Hz), medium filter (**20 Hz**), or fast filter (200 Hz) for the active channel. *The default is the medium filter.*

 LF 3 HZ:SLOW

- *Remote Interface Operation:* Specify the lowest frequency expected in the input signal on the specified channels. The instrument selects the appropriate filter based on the frequency you specify (*see table above*). The MEASure? and CONFigure commands automatically select the 20 Hz (medium) filter.

SENS:VOLT:AC:BAND 3, (@203)

*Select the slow filter (3 Hz)*

---

## Resistance Measurement Configuration

*To connect resistances to the module's screw terminals, see page 28.*

This section contains information to help you configure the instrument for making resistance measurements. Use the 2-wire method for ease of wiring and higher density or the 4-wire method for improved measurement accuracy. The measurement ranges are shown below.

100Ω	1 kΩ	10 kΩ	100 kΩ	1 MΩ	10 MΩ	100 MΩ	Autorange
------	------	-------	--------	------	-------	--------	-----------

### Offset Compensation

Offset compensation removes the effects of any DC voltages in the circuit being measured. The technique involves taking the difference between two resistance measurements on the specified channels, one with the current source turned on and one with the current source turned off.

*Applies only to 2-wire and 4-wire ohms measurements on the 100Ω, 1 kΩ, and 10 kΩ ranges.*

- For detailed information about offset compensation, see page 293.
- The instrument disables offset compensation when the measurement function is changed or after a Factory Reset (\*RST command). An Instrument Preset (SYSTem:PRESet command) or Card Reset (SYSTem:CPON command) *does not* change the setting.
- *Front-Panel Operation:* First, select the 2-wire or 4-wire ohms function on the active channel. Then, go to the *Advanced* menu and enable or disable offset compensation.

 OCOMP ON

- *Remote Interface Operation:*

RES:OCOM ON, (@208)                      *Enable offset compensation (2-wire)*  
FRES:OCOM ON, (@208)                    *Enable offset compensation (4-wire)*

For 4-wire measurements, specify the paired channel in the lower bank (source) as the *<ch\_list>* parameter.

## Current Measurement Configuration

*To connect a current source to the module's screw terminals, see page 28.*

This section contains information to help you configure the instrument for making current measurements on the 34901A multiplexer module. This module has two fused channels for direct DC and AC current measurements on the measurement ranges shown below.

10 mA	100 mA	1 A	Autorange
-------	--------	-----	-----------

**Note:** *Current measurements are allowed only on channels 21 and 22 on the 34901A module.*

### AC Low Frequency Filter

The instrument uses three different AC filters which enable you to either optimize low frequency accuracy or achieve faster AC settling times. The instrument selects the *slow*, *medium*, or *fast* filter based on the input frequency that you specify for the selected channels.

*Applies to AC current and AC voltage measurements only.*

Input Frequency	Default Settling Delay	Minimum Settling Delay
3 Hz to 300 kHz (Slow)	7 seconds / reading	1.5 seconds
20Hz to 300 KHz (Medium)	1 second / reading	0.2 seconds
200 Hz to 300 kHz (Fast)	0.12 seconds / reading	0.02 seconds

- The instrument selects the *medium* filter (20 Hz) when the function is changed or after a Factory Reset (\*RST command). An Instrument Preset (SYSTEM:PRESet command) or Card Reset (SYSTEM:CPON command) *does not* change the setting.

## Chapter 4 Features and Functions

### Current Measurement Configuration

- *Front-Panel Operation:* First, select the AC current (or AC voltage) function on the active channel. Then, go to the *Advanced* menu and select the slow filter (3 Hz), medium filter (**20 Hz**), or fast filter (200 Hz) for the active channel. *The default is the medium filter.*

 LF 3 HZ:SLOW

- *Remote Interface Operation:* Specify the lowest frequency expected in the input signal on the specified channels. The instrument selects the appropriate filter based on the frequency you specify (*see table on previous page*). The MEASure? and CONFIgure commands automatically select the 20 Hz (medium) filter.

SENS:VOLT:AC:BAND 3, (@203) *Select the slow filter (3 Hz)*

## Frequency Measurement Configuration

To connect an AC source to the module's screw terminals, see page 28.

### Low Frequency Timeout

The instrument uses three different timeout ranges for frequency measurements. The instrument selects a *slow*, *medium*, or *fast* timeout based on the input frequency that you specify for the selected channels.

Input Frequency	Default Settling Delay
3 Hz to 300 kHz (Slow)	1 s
20 Hz to 300 KHz (Medium)	100 ms
200 Hz to 300 kHz (Fast)	10 ms

- The instrument selects the *medium* timeout (20 Hz) when the function is changed or after a Factory Reset (\*RST command). An Instrument Preset (SYSTEM:PRESet command) or Card Reset (SYSTEM:CPON command) *does not* change the setting.
- *Front Panel Operation.* First, select the frequency function on the active channel. Then, go to the *Advanced* menu and select the slow timeout (3 Hz), medium timeout (**20 Hz**), or fast timeout (200 Hz) for the active channel. *The default is the medium timeout value.*

 LF 3 HZ:SLOW

- *Remote Interface Operation:* Specify the lowest frequency expected in the input signal on the specified channels. The instrument selects the appropriate timeout based on the frequency you specify (*see table above*). The MEASure? and CONFigure commands automatically select the 20 Hz (medium) timeout.

SENS:FREQ:RANG:LOW 3, (@203) *Select the slow timeout (3 Hz)*

---

## Mx+B Scaling

The scaling function allows you to apply a *gain* and *offset* to all readings on a specified multiplexer channel during a scan. In addition to setting the gain (“M”) and offset (“B”) values, you can also specify a custom measurement label for your scaled readings (RPM, PSI, etc.). You can apply scaling to any multiplexer channels and for any measurement function. Scaling *is not* allowed with any of the digital channels on the multifunction module.

- Scaling is applied using the following equation:

$$\text{Scaled Reading} = (\text{Gain} \times \text{Measurement}) + \text{Offset}$$

- You must configure the channel (function, transducer type, etc.) before applying any scaling values. If you change the measurement configuration, scaling is turned off on that channel and the gain and offset values are reset (M=1 and B=0). Scaling is also turned off when you change the temperature probe type, temperature units, or disable the internal DMM.
- If you plan to use scaling on a channel which will also use alarms, *be sure to configure the scaling values first*. If you attempt to assign the alarm limits first, the instrument will turn off alarms and clear the limit values when you enable scaling on that channel. If you specify a custom measurement label with scaling, it is automatically used when alarms are logged on that channel.
- If you remove a channel from the scan list (by selecting CHANNEL OFF from the front panel or by redefining the scan list from the remote interface), scaling is turned off for that channel but the gain and offset values *are not* cleared. If you decide to add that channel back to the scan list (without changing the function), the original gain and offset values are restored and scaling is turned back on. This makes it easy to temporarily remove a channel from the scan list without entering the scaling values again.



- You can make a null measurement on a channel and store it as the offset (“B”) for subsequent measurements. This allows you to adjust for voltage or resistive offsets through your wiring to the point of the measurement.
- During a Monitor operation, the gain and offset values are applied to all readings on the specified channel.
- You can specify a custom label with up to three characters. You can use letters (A-Z), numbers (0-9), an underscore ( \_ ), or the “#” character which displays a degree symbol ( ° ) on the front panel (displayed as a blank space in an output string from the remote interface). The first character must be a letter or the “#” character (the “#” character is allowed only as the leftmost character in the label). The remaining two characters can be letters, numbers, or an underscore.

**Note:** If you set the measurement label to °C, °F, or K, note that this has **no effect** on the temperature units set in the **Measure** menu.

- Although the instrument does not directly support strain gage measurements, you can measure a strain gage using a 4-wire resistance measurement with scaling. For more information, refer to “Strain Gage Measurements” on page 295.

**Note:** Agilent BenchLink Data Logger 3 software has built-in strain gage measurement capability.

Use the following equations to calculate the gain and offset.

$$M = \frac{1}{GF \times R_0} \quad B = -\frac{1}{GF}$$

Where  $GF$  is the gage factor and  $R_0$  is the unstrained gage resistance. For example, a 350Ω strain gage with a gage factor of 2 would use the following gain and offset values:  $M=0.001428571$ ,  $B=-0.5$  (be sure to use 6½ digits of resolution for this measurement).

**Mx+B Scaling**

- The maximum gain allowed is  $\pm 1E+15$  and the maximum offset allowed is  $\pm 1E+15$ .
- The MEASure? and CONFigure commands automatically set the gain (“M”) to 1 and offset (“B”) to 0.
- A Factory Reset (\*RST command) turns off scaling and clears the scaling values on all channels. An Instrument Preset (SYSTem:PRESet command) or Card Reset (SYSTem:CPON command) *does not* clear the scaling values and *does not* turn off scaling.
- *Front-Panel Operation:* The menu automatically guides you through the gain, offset, and measurement label settings.

**Mx+B** SET GAIN , SET OFFSET , SET LABEL

To reset the gain, offset, and measurement label to their defaults, go to the corresponding level in the menu and turn the knob. To turn scaling off (without clearing the gain and offset values), go to the first level in the menu and select SCALING OFF.

**Mx+B** SET GAIN TO 1 , SET OFST TO 0 , DEFAULT LABEL

To make a null measurement and store it as the offset, go to SET OFFSET in the menu and turn the knob.

**Mx+B** SET OFFSET

- *Remote Interface Operation:* Use the following commands to set the gain, offset, and custom measurement label.

```
CALC:SCALE:GAIN 1.2, (@101)
CALC:SCALE:OFFSET 10, (@101)
CALC:SCALE:UNIT 'PSI', (@101)
```

After setting the gain and offset values, send the following command to enable the scaling function on the specified channel.

```
CALC:SCALE:STATE ON, (@101)
```

To make a null measurement and store it as the offset, send the following command.

```
CALC:SCALE:OFFSET:NULL (@101)
```

---

## Alarm Limits

The instrument has four alarms which you can configure to alert you when a reading exceeds specified limits on a channel during a scan. You can assign a high limit, a low limit, or both to any configured channel in the scan list. You can assign multiple channels to any of the four available alarms (numbered 1 through 4). For example, you can configure the instrument to generate an alarm on the Alarm 1 output when a limit is exceeded on any of channels 103, 205, or 320.

You can also assign alarms to channels on the multifunction module. For example, you can generate an alarm when a specific bit pattern or bit pattern change is detected on a digital input channel or when a specific count is reached on a totalizer channel. With the multifunction module, the channels *do not* have to be part of the scan list to generate an alarm. *For complete details, see “Using Alarms With the Multifunction Module” on page 148.*

Alarm data can be stored in one of two locations depending on whether a scan is running when the alarm occurs.

1. If an alarm event occurs on a channel as it is being scanned, that channel's alarm status is stored in *reading memory* as the readings are taken. Each reading outside the specified alarm limits is logged in memory. You can store up to 50,000 readings in memory during a scan. You can read the contents of reading memory at any time, even during a scan. Reading memory *is not* cleared when you read it.
2. As alarm events are generated, they are also logged in an *alarm queue*, separate from reading memory. This is the *only* place where non-scanned alarms get logged (alarms during a monitor, alarms generated by the multifunction module, etc.). Up to 20 alarms can be logged in the alarm queue. If more than 20 alarm events are generated, only the first 20 alarms are saved). Even if the alarm queue is full, the alarm status is still stored in reading memory during a scan. The alarm queue is cleared by the \*CLS (clear status) command, when power is cycled, and by reading all of the entries. A Factory Reset (\*RST command) *does not* clear the alarm queue.

### Alarm Limits

- You can assign an alarm to any configured channel and multiple channels can be assigned to the same alarm number. However, you cannot assign alarms on a specific channel to more than one alarm number.
- When an alarm occurs, the instrument stores relevant information about the alarm in the queue. This includes the reading that caused the alarm, the time of day and date of the alarm, and the channel number on which the alarm occurred. The information stored in the alarm queue is always in absolute time format and is not affected by the `FORMat:READing:TIME:TYPE` command setting.
- You must configure the channel (function, transducer type, etc.) before setting any alarm limits. If you change the measurement configuration, alarms are turned off and the limit values are cleared. Alarms are also turned off when you change the temperature probe type, temperature units, or disable the internal DMM.
- If you plan to use alarms on a channel which will also use scaling, *be sure to configure the scaling values first*. If you attempt to assign the alarm limits first, the instrument will turn off alarms and clear the limit values when you enable scaling on that channel. If you specify a custom measurement label with scaling, it is automatically used when alarms are logged on that channel.
- If you remove a channel from the scan list (by selecting `CHANNEL OFF` from the front panel or by redefining the scan list from the remote interface), alarms are no longer evaluated on that channel (during a scan) but the limit values *are not* cleared. If you decide to add that channel back to the scan list (without changing the function), the original limit values are restored and alarms are turned back on. This makes it easy to temporarily remove a channel from the scan list without entering the alarm values again.
- Each time you start a new scan, the instrument clears all readings (including alarm data) stored in reading memory from the previous scan. Therefore, the contents of reading memory are always from the most recent scan.

- Alarms are logged in the alarm queue only when a reading crosses a limit, not while it remains outside the limit and not when it returns to within limits.

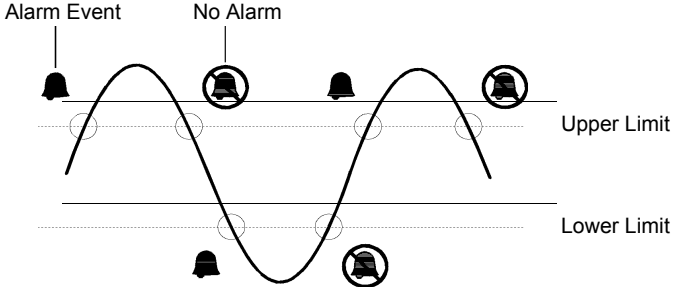

- Four TTL alarm outputs are available on the rear-panel *Alarms* connector. You can use these hardware outputs to trigger external alarm lights, sirens, or send a TTL pulse to your control system. You can also initiate a scan sweep (no external wiring required) when an alarm event is logged on a channel. For *complete details*, refer to “Using the Alarm Output Lines” on page 145.
- The following table shows the different combinations of front-panel annunciators that may appear while using alarms.

	An alarm is enabled on the displayed channel.
H 2	The indicated HI or LO limit is being configured on the indicated alarm (shown while in the <i>Alarm</i> menu).
	An alarm has occurred on one or more channels. The behavior of the alarm output lines tracks the alarm annunciators on the front panel.
ALARM	The alarm output lines have been cleared but alarms remain in the queue.

**Alarm Limits**

- In addition to being stored in reading memory, alarms are also recorded in their own SCPI status system. You can configure the instrument to use the status system to generate a Service Request (SRQ) when alarms are generated. *See the Agilent 34970A/34972A Programmer's Reference Help for more information.*
- The default values for the upper and lower alarm limits are "0". The lower limit must *always* be less than or equal to the upper limit, even if you are using only one of the limits.
- For details on configuring alarms on the multifunction module, see *"Using Alarms With the Multifunction Module" on page 148.*
- A Factory Reset (\*RST command) clears all alarm limits and turns off all alarms. An Instrument Preset (SYSTEM:PRESet command) or Card Reset (SYSTEM:CPON command) *does not* clear the alarm limits and *does not* turn off alarms.
- *Front-Panel Operation:* To select the alarm for use on the active channel, choose from the following items.

 NO ALARM , USE ALARM 1 , ... USE ALARM 4

Then, choose from the following alarm conditions.

 HI+LO ALARMS , HI ALARM ONLY , LO ALARM ONLY

Then, set the desired limit values and exit the menu. Note that the instrument does not start evaluating the alarm conditions until you exit the *Alarm* menu.

- *Remote Interface Operation:* To assign the alarm number to report any alarm conditions on the specified channels, use the following command (if not assigned, all alarms on all channels are reported on Alarm 1 by default).

```
OUTPUT:ALARM2:SOURCE (@103,212)
```

- To set the upper and lower alarm limits on the specified channels, use the following commands.



```
CALC:LIMIT:UPPER 5.25, (@103,212)
CALC:LIMIT:LOWER 0.025, (@103,212)
```

- To enable the upper and lower alarm limits on the specified channels, use the following commands.

```
CALC:LIMIT:UPPER:STATE ON, (@103,212)
CALC:LIMIT:LOWER:STATE ON, (@103,212)
```

## Viewing Stored Alarm Data

If an alarm occurs on a channel as it is being scanned, then that channel's alarm status is stored in *reading memory* as the readings are taken. As alarm events are generated, they are also logged in an *alarm queue*, which is separate from reading memory. This is the *only* place where non-scanned alarms get logged (alarms during a monitor, alarms generated by the multifunction module, etc.).

- You can store up to 50,000 readings in memory during a scan. You can read the contents of reading memory at any time, even during a scan. Reading memory *is not* cleared when you read it.
- Each time you start a new scan, the instrument clears all readings (including alarm data) stored in reading memory from the previous scan. Therefore, the contents of memory are always from the most recent scan.
- Up to 20 alarms can be logged in the alarm queue. If more than 20 alarms are generated, they will be lost (only the first 20 are saved).
- The alarm queue is cleared by the \*CLS (clear status) command, when power is cycled, and by reading all of the entries. A Factory Reset (\*RST command) or Instrument Preset (SYSTEM:PRESet command) *does not* clear the alarm queue.
- *Front-Panel Operation:* From the front panel, you can view the first 20 alarms in the queue. After turning the knob to the desired channel, press  and  to view either the alarm reading or the time that the alarm occurred. Notice that the annunciators indicate which alarm is being viewed.

 ALARMS

**Note:** The alarm queue is cleared when you read the alarms.

**Alarm Limits**

- *Remote Interface Operation:* The following command reads data from the alarm queue (one alarm event is read and cleared each time this command is executed).

SYSTEM:ALARM?

The following is an example of an alarm stored in the alarm queue (if no alarm data is in the queue, the command returns “0” for each field).

3.10090000E+01 C, 1997,04,01, 14,39,40.058, 101, 2, 1

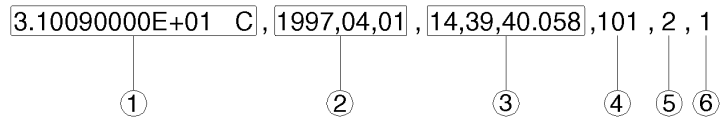

- 
- |   |  |
|---|--|
| <b>1</b> Reading with Units (31.009 °C) | <b>4</b> Channel Number  |
| <b>2</b> Date (May 1, 1997)             | <b>5</b> Limit Threshold Crossed (0 = No Alarm,<br>1 = LO, 2 = HI) |
| <b>3</b> Time (2:39:40.058 PM)          | <b>6</b> Alarm Number Reported (1, 2, 3, or 4)                     |

The following command retrieves scanned readings and alarm data from reading memory (the readings are not erased).

FETCH?



## Using the Alarm Output Lines

Four TTL alarm outputs are available on the rear-panel *Alarms* connector. You can use these hardware outputs to trigger external alarm lights, sirens, or send a TTL pulse to your control system. You can assign an alarm to any configured channel and multiple channels can be assigned to the same alarm number. Each alarm output line represents the logical “OR” of all channels assigned to that alarm number (an alarm on any of the associated channels will pulse the line).

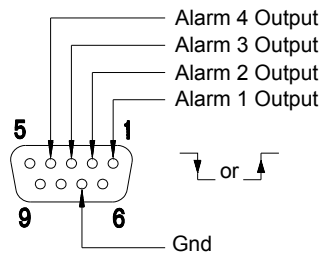

**Alarms Connector**

You can configure the behavior of the alarm output lines as described below. The behavior of the alarm annunciators on the front panel also tracks the alarm output configuration. The configuration that you select is used for all four alarm output lines. A Factory Reset (\*RST command) clears all four alarm outputs but *does not* clear the alarm queue in either configuration.

- **Latch Mode:** In this mode, the corresponding output line is latched true when the first alarm occurs and remains asserted until you clear it by initiating a new scan or cycling power. You can manually clear the output lines at any time (even during a scan) and the alarm data in memory is not cleared (however, data is cleared when you initiate a new scan).

**Alarm Limits**

- *Track Mode*: In this mode, the corresponding output line is asserted only when a reading crosses a limit and remains outside the limit. When a reading returns to within limits, the output line is automatically cleared. You can manually clear the output lines at any time (even during a scan) and the alarm data in memory *is not* cleared (however, data is cleared when you initiate a new scan). The alarm outputs are also cleared when you initiate a new scan.
- You can control the slope of the pulse from the alarm outputs (the selected configuration is used for all four outputs). In the *falling edge* mode, 0V (TTL low) indicates an alarm. In the *rising edge* mode, +5V (TTL high) indicates an alarm. A Factory Reset (\*RST command) will reset the slope to *falling edge*.

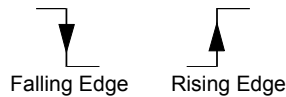

**Note:** Changing the slope of the output lines may cause the lines to change state.

- *Front-Panel Operation*: To specify if you want to manually clear all four alarm outputs, choose from the following items.

Alarm Out DO NOT CLEAR , CLEAR OUTPUTS

To select the output configuration for all four output lines, choose from the following items.

Alarm Out LATCH ON FAIL , TRACK PASS/F

To configure the slope of all four output lines, choose from the following items.

Alarm Out FAIL = HIGH , FAIL = LOW

- *Remote Interface Operation:* To clear the specified output lines (or to clear all four lines), use one of the following commands.

```
OUTPUT:ALARM2:CLEAR      Clear alarm output line 2  
OUTPUT:ALARM:CLEAR:ALL  Clear all four alarm outputs
```

To select the output configuration for all four output lines, use the following command.

```
OUTPut:ALARm:MODE {LATCH|TRACK}
```

To configure the slope of all four output lines, use the following command.

```
OUTPut:ALARm:SLOPe {NEGative|POSitive}
```

**Alarm Limits****Using Alarms With the Multifunction Module**

You can configure the instrument to generate an alarm when a specific bit pattern or bit pattern change is detected on a digital input channel or when a specific count is reached on a totalizer channel. These channels *do not* have to be part of the scan list to generate an alarm. Alarms are evaluated continuously as soon as you enable them.

- The digital input channels are numbered “s01” (lower byte) and “s02” (upper byte), where *s* represents the slot number. The totalizer channel is numbered “s03”.
- Alarms are evaluated continuously on the multifunction module, but alarm data is stored in reading memory *only* during a scan.
- Each time you start a new scan, the instrument clears all readings (including alarm data) stored in reading memory from the previous scan. However, alarm data stored in the alarm queue from the multifunction module *is not* cleared. Therefore, although the contents of reading memory are always from the most recent scan, the alarm queue may contain data that occurred during previous scans or while the instrument was not scanning.
- *Front-Panel Operation:* To configure an alarm on a digital input channel, choose from the following items and then set the desired bit pattern. Set each bit to “0”, “1”, or “X” (don’t care). You can either specify that an alarm will occur when certain bits change or when a specific 8-bit pattern is read.

 NOT PATTERN , PATTERN MATCH

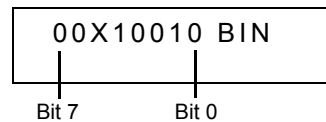

To configure an alarm on a totalizer channel, select a high limit and then set the desired count for the selected alarm.

 HI ALARM ONLY

- *Remote Interface Operation (Digital Input Channel)*: To assign the alarm number to report any alarm conditions on the specified digital input channels, use the following command.

```
OUTPut:ALARm[1|2|3|4]:SOURce (@<ch_list>)
```

To configure alarms on the specified digital input channel, use the following commands (*also see the example on the following page*).

```
CALCulate
:COMPare:TYPE {EQUAL|NEQUAL}[, (@<ch_list>)]
:COMPare:DATA <data>[, (@<ch_list>)]
:COMPare:MASK <mask>[, (@<ch_list>)]
```

Select `EQUAL` to generate an alarm when the data read from the port is equal to `CALC:COMP:DATA` after being masked by `CALC:COMP:MASK`. Select `NEQUAL` (not equal) to generate an alarm when the data read from the port *is not* equal to `CALC:COMP:DATA` after being masked by `CALC:COMP:MASK`.

Use `CALC:COMP:MASK` to designate the “don’t care” bits. Bits that you set to “0” in the mask are ignored.

To enable the specified alarm mode, send the following command.

```
CALCulate:COMPare:STATe ON [, (@<ch_list>)]
```

**Alarm Limits*****Example: Configuring an Alarm on a Digital Input***

Assume that you want to generate an alarm when a binary pattern of “1000” is read on the upper four bits of port 1. Send the following commands to configure the port for an alarm.

```
CALC:COMP:TYPE EQUAL, (@301)
CALC:COMP:DATA 128, (@301)
CALC:COMP:MASK 240, (@301)
OUTPUT:ALARM2:SOURCE (@301)
CALC:COMP:STATE ON, (@301)
```

Here are the calculations used to evaluate the alarm (assume that a decimal 146 was read from the port):

A	B	X-OR
0	0	0
0	1	1
1	0	1
1	1	0

A	B	AND
0	0	0
0	1	0
1	0	0
1	1	1

```

Bit 7           Bit 0
1 0 0 1 0 0 1 0
1 0 0 0 0 0 0 0
0 0 0 1 0 0 1 0
1 1 1 1 0 0 0 0
0 0 0 1 0 0 0 0
```

*Data read from port (decimal 146)*

*CALC:COMP:DATA command (decimal 128)*

*“X-OR” result*

*CALC:COMP:MASK command (decimal 240)*

*“AND” result (no alarm generated)*

Since the calculations produce a non-zero result (decimal 16), an alarm is not generated in this example.

- **Remote Interface Operation (Totalizer Channel):** To assign the alarm number to report any alarm conditions on the specified totalizer channels, use the following command.

```
OUTPUT:ALARM[1|2|3|4]:SOURCE (@<ch_list>)
```

To configure an alarm on a totalizer channel, specify the desired count as the upper limit using the following command.

```
CALCulate:LIMit:UPPer <count>[, (@<ch_list>)]
```

To enable the upper limit on the specified totalizer channel, use the following command.

```
CALCulate:LIMit:UPPer:STATE ON [, (@<ch_list>)]
```

---

## Digital Input Operations

The multifunction module (34907A) has two non-isolated 8-bit input/output ports which you can use for reading digital patterns. You can read the live status of the bits on the port or you can configure a scan to include a digital read.

- The digital input channels are numbered “s01” (lower byte) and “s02” (upper byte), where **s** represents the slot number.
- You can generate an alarm when a specific bit pattern or bit pattern change is detected on an input channel. With the multifunction module, the channels *do not* have to be part of the scan list to generate an alarm. *For more information, see “Using Alarms With the Multifunction Module” on page 148.*
- When you add a digital read to a scan list, that port is dedicated to the scan. The instrument issues a Card Reset to make that port an input port (the other port is not affected). While included in the scan list, you can still perform low-level read operations on the port, but you cannot perform write operations on the port.
- From the front panel, you can read data from only one 8-bit input port at a time. From the remote interface, you can read both ports simultaneously as a 16-bit word *only* if neither port is in the scan list. If one or both ports are included in the scan list, you can read only one 8-bit port at a time. However, if you have included both ports in the scan list, the data *will* be read from both ports simultaneously and will have the same time stamp. Therefore, you can externally combine the two 8-bit quantities into a 16-bit quantity.
- From the front-panel only, you can specify whether you want to use binary or decimal format (readings are always stored in memory in decimal format). Once you have selected the number base, it is used for all input or output operations on the same port.
- You can monitor a digital input channel even if the channel is not part of the scan list (the internal DMM is not required either).

**Digital Input Operations**

- A Factory Reset (\*RST command), Instrument Preset (SYSTEM:PRESet command), and Card Reset (SYSTEM:CPON command) from the remote interface will reconfigure both ports as input ports.

Note that a  from the front panel resets only the port currently selected (both ports are not reset).

- *Front-Panel Operation:* After selecting the port, press  to read the bit pattern (the least significant bit is on the right). The bit pattern read from the port will be displayed until you press another key, turn the knob, or until the display times out.

To add a digital read to a scan list, choose the following item.

 DIO READ

From the front-panel only, you can specify whether you want to use binary or decimal format.

 USE DECIMAL , USE BINARY

- *Remote Interface Operation:* From the remote interface, you can read an 8-bit byte from one port or a 16-bit word from both ports using the following commands. If you are going to read both ports simultaneously, you must send the command to port 01 and neither port can be included in the scan list

SENS:DIG:DATA:BYTE? (@302)	<i>Read port 02</i>
SENS:DIG:DATA:WORD? (@301)	<i>Read both ports together</i>

To redefine the scan list to include a digital read (8-bit read only), send the following command.

CONF:DIG:BYTE (@302)	<i>Add port 02 read to scan list</i>
----------------------	--------------------------------------



## Totalizer Operations

The multifunction module has a 26-bit totalizer which can count TTL pulses at a 100 kHz rate. You can manually read the totalizer count or you can configure a scan to read the count.

- The totalizer channel is numbered “s03”, where **s** represents the slot number.
- You can configure the instrument to count on the rising edge or falling edge of the input signal.
- You can control when the totalizer actually records counts by providing a *gate signal* (G and  $\bar{G}$  terminals on the module). A TTL high signal applied to the “G” terminal enables counting and a low signal disables counting. A TTL low signal applied to the “ $\bar{G}$ ” terminal enables counting and a high signal disables counting. The totalizer only counts when both terminals are enabled. You can use either the G terminal, the  $\bar{G}$  terminal, or both. *When a gate is not connected, the gate terminal floats to the enabled state, effectively creating a “gate always” condition.*

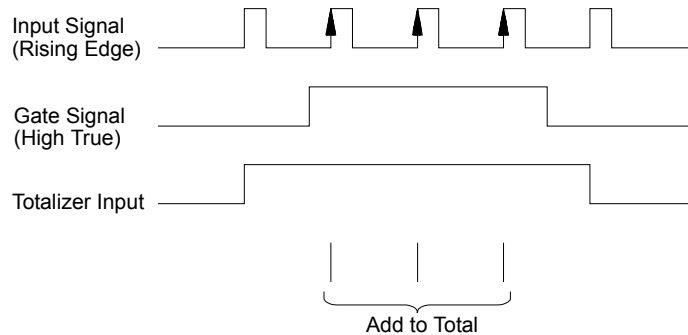

**Totalizer Operations**

- Using the hardware jumper labeled “Totalize Threshold” on the module, you can control the threshold at which an edge is detected. Move the jumper to the “AC” position to detect changes through 0 volts. Move the jumper to the “TTL” position (factory setting) to detect changes through TTL threshold levels.

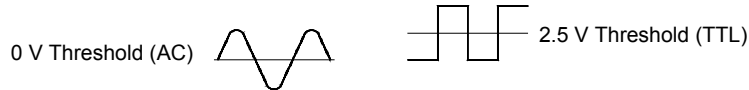

The maximum count is 67,108,863 ( $2^{26} - 1$ ). The count rolls over to “0” after reaching the maximum allowed value.

- You can configure the totalizer to reset its count after it is read without losing any counts (TOTAlize:TYPE RRESet command). Then, if the totalizer is included in a scan list, the count will be reset on every scan sweep. The count is also reset whenever it is read directly by pressing  from the front panel or when sending the SENSE:TOTAlize:DATA? command.
- You can configure the instrument to generate an alarm when a specific count is reached on a totalizer channel. These channels *do not* have to be part of the scan list to generate an alarm. Alarms are evaluated continuously as soon as you enable them. For more information, see “Using Alarms With the Multifunction Module” on page 148.
- You can monitor a totalizer channel even if the channel is not part of the scan list (the internal DMM is not required either). The count on a totalizer channel *is not* reset when it is being monitored (the Monitor ignores the totalizer reset mode).
- A Factory Reset (\*RST command), Instrument Preset (SYSTEM:PRESet command), and Card Reset (SYSTEM:CPON command) reset the count to “0”.

- *Front-Panel Operation:* After selecting the totalizer, press **Read** to read the count. If you have selected the READ+ RESET mode, the count is reset each time it is read. The count is displayed until you press another key, turn the knob, or until the display times out.

To configure the totalizer reset mode, choose from the following items.

**Advanced** READ , READ + RESET

To configure the totalizer to count on the falling edge or rising edge of the input signal, choose from the following items.

**Advanced** COUNT FALLING , COUNT RISING

- To add a totalizer read to a scan list, choose the following item.

**Advanced** TOT READ

**Totalizer Operations**

- *Remote Interface Operation:* To read the count from the specified totalizer channel, send the following command. The count may be returned with time stamp, channel number, and alarm status information depending on the `FORMat:READing` command setting (see “Reading Format” on page 104 for more information).

```
SENS:TOT:DATA? (@303)
```

To configure the totalizer reset mode, send either of the following commands (`RRESet` means “read and reset”).

```
SENSe:TOTalize:TYPE {READ|RRESet} [, (@<ch_list>)]
CONFIgure:TOTalize {READ|RRESet} , (@<scan_list>)
```

To configure the totalizer to count on the falling edge (*negative*) or rising edge (*positive*) of the input signal, send the following command.

```
SENSe:TOTalize:SLOPe {NEG|POS} , [ (@<ch_list>)]
```

To immediately clear the count on the specified totalizer channel (whether scanning or not), send the following command.

```
SENSe:TOTalize:CLEar:IMMediate [ (@<ch_list>)]
```



---

## Digital Output Operations

The multifunction module (34907A) has two non-isolated 8-bit input/output ports which you can use for outputting digital patterns.

- The digital output channels are numbered “s01” (lower byte) and “s02” (upper byte), where **s** represents the slot number.
- You cannot configure a port for output operations if that port is already configured to be part of the scan list (digital input).
- From the front panel, you can write to one 8-bit output port at a time. From the remote interface, you can write to both ports simultaneously.
- From the front-panel only, you can specify whether you want to use binary or decimal format. Once you have selected the number base, it is used for all input or output operations on the same port.
- A Factory Reset (\*RST command), Instrument Preset (SYSTEM:PRESet command), and Card Reset (SYSTEM:CPON command) from the remote interface will reconfigure both ports as input ports.

**Note:** A  from the front panel resets only the port currently selected (both ports are not reset).

- *Front-Panel Operation:* After selecting the output port, press  to edit the bit pattern or decimal value (the least significant bit is on the right). Press  again to output the bit pattern. To cancel an output operation in progress, wait for the display to time out.

From the front-panel only, you can specify whether you want to use binary or decimal format.

 USE DECIMAL , USE BINARY

**Digital Output Operations**

- *Remote Interface Operation:* From the remote interface, you can output an 8-bit byte to one port or a 16-bit word to both ports simultaneously using the following commands. You must specify a decimal value (binary data is not accepted). If you are going to read both ports simultaneously, you must send the command to port 01.

```
SOUR:DIG:DATA:BYTE 10 , (@302)      Write to port 02  
SOUR:DIG:DATA:WORD 10327 , (@301)   Write to both ports
```

---

## DAC Output Operations



The multifunction module (34907A) has two low-noise analog outputs capable of outputting calibrated voltages between  $\pm 12$  volts with 16 bits of resolution. Each DAC (Digital-to-Analog Converter) channel can be used as a programmable voltage source for analog input control of other devices.

- On the multifunction module, the DAC channels are numbered “s04” and “s05”, where **s** represents the slot number.
- You can set the output voltage to any value between +12 VDC and -12 VDC, in 1 mV steps. Each DAC is earth referenced; *it cannot float*.
- Each DAC channel is capable of 10 mA maximum output current.

**Note:** You must limit the output current to 40 mA total for all three slots (six DAC channels).

- A Factory Reset (\*RST command), Instrument Preset (SYSTEM:PRESet command), and Card Reset (SYSTEM:CPON command) from the remote interface will reset both DACs to 0 VDC.

**Note:** A  from the front panel resets only the DAC currently selected (both channels are not reset).

- *Front-Panel Operation:* After selecting the desired DAC, press  to edit the output voltage. Press  again to output the specified voltage from the DAC channel.
- *Remote Interface Operation:* The following command outputs +2.5 VDC from the DAC on channel 05.

```
SOURCE:VOLT 2.5, (@305)
```

## System-Related Operations

This section gives information on system-related topics such as storing instrument states, reading errors, running a self-test, displaying messages on the front panel, setting the system clock, disabling the internal DMM, reading the firmware revisions, and reading the relay cycle count.

### State Storage

The instrument has six storage locations in non-volatile memory to store instrument states. The locations are numbered 0 through 5. The instrument uses location “0” to automatically hold the state of the instrument at power down. You can also assign a name to each of the locations (1 through 5) for use from the front panel.

- You can store the instrument state in any of the six locations. However, you can only recall a state from a location that contains a previously stored state. You can use location “0” to store a sixth instrument state. However, keep in mind that location “0” is automatically overwritten when power is cycled.
- The instrument stores the state of all modules including all channel configurations, scanning setups, alarm values, and scaling values.
- When shipped from the factory, storage locations “1” through “5” are empty (location “0” has the power-on state).
- When shipped from the factory, the instrument is configured to automatically recall the power-down state (state “0”) when power is restored. You can change the factory configuration such that a Factory Reset (\*RST command) is issued when power is restored.
- Before recalling a stored state, the instrument verifies that the same module types are installed in each slot. If a different module type is installed, the instrument will perform the equivalent of a Card Reset (SYSTem:CPON command) on that slot.



- You can assign a name to the storage locations (you cannot assign a name to location “0”). You can name a location from the front panel or over the remote interface but you can only recall a named state from the front panel. From the remote interface, you can only recall a stored state using a number (0 through 5).
- The name can contain up to 12 characters. The first character *must* be a letter (A-Z), but the remaining 11 characters can be letters, numbers (0-9), or the underscore character (“\_”). Blank spaces are not allowed. An error is generated if you specify a name with more than 12 characters.
- A Factory Reset (\*RST command) does not affect the configurations stored in memory. Once a state is stored, it remains until it is overwritten or specifically deleted.
- *Front-Panel Operation:*

**Sto/Rcl** NAME STATE , STORE STATE , RECALL STATE

After recalling a stored state, you will notice that a new choice (UNDO RECALL) is added under RECALL STATE. This allows you to cancel the last recall operation and revert to the previous state. You can also select LAST PWR DOWN to recall the state of the instrument at the power-down.

To configure the instrument to recall the power-down state or issue a Factory Reset when power is restored, select from the following.

**Utility** PWR ON LAST , PWR ON RESET

- *Remote Interface Operation:* Use the following commands to store and recall instrument states (state “0” is the state of the instrument at power down).

\*SAV {0|1|2|3|4|5}

\*RCL {0|1|2|3|4|5}

## Chapter 4 Features and Functions

### System-Related Operations

To assign a name to a stored state to be recalled from the front panel, send the following command. From the remote interface, you can only recall a stored state using a number (0 through 5).

```
MEM:STATE:NAME 1,TEST_RACK_1
```

To configure the instrument to automatically issue a Factory Reset (\*RST command) when power is restored, send the following command.



```
MEMory:STATe:RECall:AUTO OFF
```

## Error Conditions

When the front-panel **ERROR** annunciator turns on, one or more command syntax or hardware errors have been detected. A record of up to 10 errors (34970A) or 20 errors (34972A) is stored in the instrument's *error queue*. See chapter 6 for a complete listing of the errors.

- Errors are retrieved in first-in-first-out (FIFO) order. The first error returned is the first error that was stored. Errors are cleared as you read them. When you have read all errors from the queue, the **ERROR** annunciator turns off and the errors are cleared. The instrument beeps once each time an error is generated.
- If more than 10 errors (34970A) or 20 errors (34972A) have occurred, the last error stored in the queue (the most recent error) is replaced with “*Error queue overflow*”. No additional errors are stored until you remove errors from the queue. If no errors have occurred when you read the error queue, the instrument responds with “*No error*”.
- The error queue is cleared by the \*CLS (clear status) command or when power is cycled. The errors are also cleared when you read the queue. The error queue is not cleared by a Factory Reset (\*RST command) or an Instrument Preset (SYSTEM:PRESet command).
- *Front-Panel Operation:*

 ERRORS

If the **ERROR** annunciator is on, press  to view the error. Use the knob to scroll through the error numbers. Press  to view the text of the error message. Press  again to increase the scrolling speed (the final key press cancels the scroll). All errors are cleared when you exit the menu.

- *Remote Interface Operation:*

SYSTEM:ERROR?     *Read and clear one error from the queue*

Errors have the following format (the error string may contain up to 80 characters):

```
-113, "Undefined header"
```

## Self-Test

A *power-on* self-test occurs automatically when you turn on the instrument. This limited test assures you that the instrument and all installed plug-in modules are operational. This self-test does not perform the extensive set of tests that are included as part of the complete self-test described below.

A *complete* self-test runs a series of tests and takes approximately 20 seconds to execute. If all tests pass, you can have a high confidence that the instrument and all installed plug-in modules are operational.



- If the complete self-test is successful, **PASS** is displayed on the front panel. If the self-test fails, **FAIL** is displayed and the **ERROR** annunciator turns on. See the *34970A/34972A Service Guide* for instructions on returning the instrument to Agilent for service.
- *Front-Panel Operation:* To perform the complete front-panel self-test, hold down **Shift** as you turn on the instrument and *hold down the key until you hear a long beep*. The self-test will begin when you release the key following the beep.
- *Remote Interface Operation:*

\*TST?

Returns "0" if the self-test is successful or "1" if it fails.

## Display Control

For security reasons or for a slight increase in scanning rates, you may want to turn off the front-panel display. From the remote interface, you can also display a 13-character message on the front-display.

- You can only disable the front-panel display by sending a command from the remote interface (you cannot disable the front panel while in local operation).
- When disabled, the entire front-panel display goes blank and all display annunciators except **ERROR** are disabled. All keys except  are locked out when the display is disabled.
- The display is automatically enabled when power is cycled, after a Factory Reset (\*RST command), or when you return to local by pressing .
- You can display a message on the front panel by sending a command from the remote interface. The instrument can display up to 13 characters on the front panel; if you attempt to send more than 13 characters, an error is generated. You can use letters (A-Z), numbers (0-9), and special characters like “@”, “%”, “\*”, etc. Use the “#” character to display a degree symbol (°). Commas, periods, and semicolons share a display space with the preceding character, and are not considered individual characters. While a message is displayed on the front panel, readings from a scan or monitor are not sent to the display.
- Sending a message to the display from the remote interface overrides the display state; this means that you can display a message even if the display is turned off.

## Chapter 4 Features and Functions

### System-Related Operations

- *Remote Interface Operation:* The following command turns off the front panel display.

```
DISPLAY OFF
```

The following command displays a message on the front panel and turns on the display if disabled.

```
DISP:TEXT ' SCANNING ... '
```

To clear the message displayed on the front panel (without changing the display state), send the following command.

```
DISPLAY:TEXT:CLEAR
```

### Real-Time System Clock

During a scan, the instrument stores all readings and alarms with the current time and date. The instrument stores the time and date information in non-volatile memory.

- When shipped from the factory, the instrument is set to the current time and date (U.S. Mountain Time).
- *Front-Panel Operation:*

 TIME 03:45 PM

 JUN 01 1997

- *Remote Interface Operation:* Use the following commands to set the time and date.

```
SYST:TIME 15,45,00      Set time to 3:45 PM  
SYST:DATE 1997,06,01   Set date to June 1, 1997
```

## Internal DMM Disable

You can scan through the configured channels using either the internal DMM or an external instrument. For externally-controlled scans, you must either remove the internal DMM from the instrument or

- For information on controlling a scan with an external instrument, refer to “*Scanning With External Instruments*” on page 111.
- When shipped from the factory, the internal DMM is enabled. When you change the state of the internal DMM, the instrument issues a Factory Reset (\*RST command).
- A Factory Reset (\*RST command) or Instrument Preset (SYSTEM:PRESet command) *does not* affect the internal DMM configuration.
- *Front-Panel Operation:*

 DMM ENABLED , DMM DISABLED

- *Remote Interface Operation:*

```
INSTrument:DMM {OFF|ON}
```

## Firmware Revision Query

The instrument has three microprocessors for control of various internal systems. Each plug-in module also has its own on-board microprocessor. You can query the instrument and each module to determine which revision of firmware is installed for each microprocessor.

- The instrument returns three revision numbers. The first number is the firmware revision number for the measurement processor; the second is the input/output processor; and the third is the front-panel display processor. For each plug-in module, the instrument returns one revision number for the on-board processor.

## Chapter 4 Features and Functions

### System-Related Operations

- *Front-Panel Operation:*

 REV X.X-Y.Y-Z.Z (for 34970A)  
REV X.XX-Y.YY-Z (for 34972A)

Turn the knob to read the firmware revision number for the module installed in each of the three slots. If a slot does not contain a module, EMPTY SLOT is displayed.

- *Remote Interface Operation:* Use the following command to read the system firmware revision numbers (be sure to dimension a string variable with at least 40 characters).

```
*IDN?
```

The above command returns a string in the form:

```
HEWLETT-PACKARD,34970A,0,X.X-Y.Y-Z.Z  
Agilent Technologies,34972A,0,I.II-O.OO-FP-FPGA
```

See the *Agilent 34970A/34972A Programmer's Reference Help* for details.

Use the following command to read the firmware revision number of the module in the specified slot (be sure to dimension a string variable with at least 30 characters).

```
SYSTem:CTYPe? {100|200|300}
```

This command returns a string in the form:

```
HEWLETT-PACKARD,34901A,0,X.X (for 34970A)  
Agilent Technologies,0,0,0 (for 34970A)
```

See the *Agilent 34970A/34972A Programmer's Reference Help* for details.



## Relay Cycle Count

The instrument has a *Relay Maintenance System* to help you predict relay end-of-life. The instrument counts the cycles on each relay in the instrument and stores the total count in non-volatile memory on each switch module. You can use this feature on any of the relay modules and the internal DMM.

- In addition to the channel relays, you can also query the count on backplane relays and bank relays. Note that you cannot control the state of these relays from the front panel but you can query the count. For more information on channel numbering and layout, refer to “*Module Overview*” starting on page 200.
- You can also query the state of the three relays on the internal DMM. These relays are numbered “1”, “2”, and “3” (which correspond to relays K102, K103, and K104 respectively). These relays open or close when a function or range is changed on a module.
- The 34908A multiplexer contains 40 channels which are switched (HI only) using only 20 relays. Each relay is used to switch HI on two different channels (and only one channel can be closed at a time). The channels are arranged such that channels 01 and 21 use different contacts on the same relay. The remaining channels are also paired in the same manner (channels 02 and 22, channels 03 and 23, etc.). Therefore, when you query the relay count on a channel, the number reflects the number of times that the relay was closed. For example, the relay count will always be the same on channels 01 and 21.
- You can reset the count (allowed only from remote) but the instrument must be unsecured (see “*Calibration Overview*” on page 192 to unsecure the instrument).
- For more information on relay life and load considerations, refer to “*Relay Life and Preventive Maintenance*” starting on page 321.

- *Front-Panel Operation:* To read the count on the active channel, choose the following item and then turn the knob. To read the count on the internal DMM relays, turn the knob counterclockwise beyond the lowest numbered channel in the instrument. To read the “hidden” backplane and bank relays, turn the knob clockwise beyond the highest numbered channel in the current slot.

 RELAY CYCLES

- *Remote Interface Operation:* To read the relay count on either the internal DMM (all three relays) or the specified module channels, send the following commands.

```
DIAG:DMM:CYCLES?
```

```
DIAG:RELAY:CYCLES? (@305,399)
```

To clear the count on either the specified internal DMM relay or the specified module channels (the instrument must be unsecured), send the following commands.

```
DIAG:DMM:CYCLES:CLEAR 2
```

```
DIAG:RELAY:CYCLES:CLEAR (@305,399)
```

---

## Single-Channel Monitoring



In the Monitor function, the instrument takes readings as often as it can on a single channel, even during a scan. This feature is useful for troubleshooting your system before a test or for watching an important signal.

Any channel that can be “read” by the instrument can be monitored. This includes any combination of temperature, voltage, resistance, current, frequency, or period measurements on multiplexer channels. You can also monitor a digital input port or the totalizer count on the multifunction module. Monitoring *is not* allowed with the actuator module, the matrix module, or the RF multiplexer modules.

- The Monitor function is equivalent to making continuous measurements on a single channel with an infinite scan count. Only one channel can be monitored at a time but you can change the channel being monitored at any time.
- Readings acquired during a Monitor *are not* stored in memory but they are displayed on the front panel (however, all readings from a scan in progress at the same time are stored in memory).
- Mx+B scaling and alarm limits are applied to the selected channel during a Monitor and all alarm data is stored in the alarm queue (which will be cleared if power fails).
- A scan in progress always has priority over the Monitor function. The instrument will take *at least* one monitor reading per scan sweep and will take more as time permits.
- You can monitor a multiplexer channel only if the internal DMM is installed and enabled (*see “Internal DMM Disable” on page 167*). The channel must also be configured to be part of the scan list.
- You can monitor a digital input channel or totalizer channel even if the channel is not part of the scan list (the internal DMM is not required either). The count on a totalizer channel *is not* reset when it is being monitored (the Monitor ignores the totalizer reset mode).

## Chapter 4 Features and Functions

### Single-Channel Monitoring

- In the Alarm Scan configuration (see “*Scanning on Alarm*” on page 100), the instrument sweeps the scan list once each time a reading crosses an alarm limit on a channel. In this configuration, you may use the Monitor function to continuously take readings on a selected channel and wait for an alarm on that channel. The monitored channel can be part of the scan list but you can also use a channel on the multifunction module (which does not have to be part of the scan list and you do not have to use the Monitor function).
- *Front-Panel Operation:* To start a Monitor, press . Turn the knob to advance to the desired channel. The instrument begins monitoring after you pause for a few seconds on a configured channel.
- To stop a Monitor press  again. Note that while the instrument is in the remote mode, you can still turn on the Monitor function and select the desired channel.
- *Remote Interface Operation:* The following program segment selects the channel to be monitored (specify only one channel) and enables the Monitor function.

```
ROUT:MON (@101)
ROUT:MON:STATE ON
```

To read the monitor data from the selected channel, send the following command. This command returns the reading only; the units, time, channel, and alarm information *are not* returned (the `FORMat:READing` commands do not apply to monitor readings).

```
ROUT:MON:DATA?
```

## SCPI Language Version Query

The instrument complies with the rules and conventions of the present version of SCPI (*Standard Commands for Programmable Instruments*). You can determine the SCPI version with which the instrument is in compliance by sending a command from the remote interface.

*You cannot query the SCPI version from the front panel.*

- The following command returns the SCPI version.

```
SYSTem:VERSion?
```

*Returns a string in the form “YYYY.V”, where “YYYY” represents the year of the version, and “V” represents a version number for that year (for example, 1994.0).*

## Mass Memory (USB) Subsystem - 34972A

This section gives information on the mass memory subsystem (34972A only). The mass memory subsystem enables you to capture data to, or import an instrument configuration from a USB drive connected to the instrument's USB port.

### General Capabilities

The mass memory subsystem supports the following capabilities:

1. Automatic streaming of scanned data to USB drive during scan.
  - Files are automatically named.
  - Data is logged to USB drive and reading memory simultaneously. Most internal operations of the instrument continue to operate on reading memory.
  - If you are using `TRIGger:COUNT INfinity` and capturing more than 50,000 readings, reading memory will fill and then overflow, discarding the oldest data. The USB streaming will continue after reading memory overflows, allowing you to capture all of the data (up to  $2^{32}$  sweeps, or up to the limits imposed by the USB drive).
2. Copying of data from reading memory to USB drive
  - Files are automatically named.
  - After a scan finishes, you can export reading memory to your USB drive (up to 50,000 readings).
3. Setup of your instrument based on channel configurations specified in Agilent BenchLink Data Logger.
  - Agilent BenchLink Data Logger allows you save configuration (BLCFG) files on the USB drive. You can then import the file on the USB drive into your instrument.

There are two annunciators related to the USB drive:

**MEM** (on) - Indicates that a USB drive is connected to the 34972A.

**MEM** (flashing) - Indicates the the USB drive is either streaming data to USB (logging), copying from reading memory to USB (exporting), or importing a configuration from Agilent BenchLink Data Logger.

**AUTO** (on) - Indicates that logging is active.

- To avoid data loss or incomplete instrument configuration, do not remove the USB drive while **MEM** is flashing.
4. Management of files on the USB drive via File Transfer Protocol (FTP). You would typically use FTP to download and delete files from the USB drive attached to the 34972A. A typical FTP session is shown below.
- From a command prompt, enter **FTP AAA.BBB.CCC.DDD** to start the FTP session. Use the numbers of your instrument's IP address in place of **AAA.BBB.CCC.DDD**.
  - The software will ask for a user name and password. The user name is **Anonymous**, and the password is any string, such as **xyz**.
  - Enter the command **CD DATA** to log onto the USB drive.
  - Enter the command **DIR** to obtain a directory of the USB drive.
  - Enter the command **CD MY00012345/20091210\_134523123** to change to the directory containing the data you wish to download from the USB drive to your local computer. Of course, the exact directory name will vary.
  - Enter the command **ascii** to ensure that you transfer the appropriate file type.
  - Enter the command **get dat00001.csv** to download that specific file, or enter **mget \*.csv** to download all files ending in CSV. The **MEM** annunciator will not flash during the download.
  - Enter the command **delete data00001.csv** to delete a specific file, or enter **mdelete \*.csv** to delete all files ending in CSV.
  - Enter the command **quit** to leave the FTP session.

Refer to your computer's FTP documentation for further details.





## SCPI Commands

This section concentrates on the features available from the front panel; you can also control the mass memory subsystem with the following SCPI commands:

- `MMEMory:FORMat:READing:CSEPARATOR <column_separator>`
- `MMEMory:FORMat:READing:CSEPARATOR?`
- `MMEMory:FORMat:READing:RLIMit <row_limit>`
- `MMEMory:FORMat:READing:RLIMit?`
- `MMEMory:LOG[:ENABLE] <state>`
- `MMEMory:LOG[:ENABLE]?`
- `MMEMory:EXPort?`
- `MMEMory:IMPort:CONFiguration? "<configuration_file>"`
- `MMEMory:IMPort:CATalog?`

For more information on the SCPI commands available to program the instrument over the remote interface, see the MMEMory commands in the *Agilent 34970A/34972A Programmer's Reference Help*.

## Folder and File Structure

### *Folder Description*

Each saved scan will be stored in a top-level folder named:

`/34972A/data/[instrument_SN]/[yyyymmdd_hhmmssmmm]`

The square brackets ( [ ] ) are not actually part of the directory name, and the `yyyymmdd_hhmmssmmm` is a timestamp indicating the approximate start of the scan. The format is year (yyyy), month (mm), day (dd), underscore (\_), hours (hh), minutes (mm), seconds (ss), and milliseconds (mmm).

For example, the folder named:

`/34972A/data/MY00012345/20091210_134523123`

would indicate a scan on instrument number MY00012345 that started approximately 23.123 seconds after 1:45 pm (13:45) on December 10, 2009.

### ***File Descriptions***

The top level folder described above will contain two types of files. The first is a file named as follows:

#### **config.csv**

This is a text file that documents the instrument configuration for this scan. The timestamp is as described above. This file lists the configuration of the instrument in a human readable form.

In addition to the config.csv file, you will have one or more data files named as follows:

#### **dat#####.csv**

If you use the command `MMEMoRY:FORMat:READing:RLIMit OFF`, all of the data will be stored in one file, named **dat00001.csv**.

You can issue the command `MMEMoRY:FORMat:READing:RLIMit ON` to limit the data to 64K - 1 (65,535) sweeps per file, in which case the sweeps are stored in multiple files, named **dat00001.csv**, **dat00002.csv**, **dat00003.csv**, and so on. This is helpful for importing data into spreadsheet or other data analysis software. Note that some spreadsheet or data analysis software may import the data more easily if you change the extension from **csv** to **txt**. If your software does not import the file correctly, try changing the extension on the data file.

## Contents of Data Files

Logging into data files is only supported for channels that are in the scan list. The possible channels are shown in the table below; note that **s** stands for the slot number, which is 1, 2, or 3.

For example, the 34901A module supports could have channels 101-120, 201-220, or 301-320.

Module	Description	Channels
34901A	20-channel, 2-wire armature multiplexer	s01-s20
34902A	16 channel, 2-wire reed multiplexer	s01-s16
34907A	2-channel DIO input	s01-s02
34907A	1-channel totalizer	s03
34908A	40-channel, 1-wire armature multiplexer	s01-s40

The format for all USB data files is similar to what Agilent BenchLink Data Logger produces by default. The default field separator is a comma, but you can use the following command to specify a different separator.

**MMEMory:FORMat:READing:CSEPARATOR {TAB|COMMa|SEMIColon}**

Chapter 4 Features and Functions  
**Mass Memory (USB) Subsystem - 34972A**

A sample file is shown below.

Sweep #	Time	Chan 201 (VDC)	Chan 202 (VDC)
1	01/26/2009 08:07:12:237	0.36823663	1.23895216
2	01/26/2009 08:07:13:237	0.62819233	0.98372939
3	01/26/2009 08:07:14:237	0.38238212	0.39382906
4	01/26/2009 08:07:15:237	0.46773299	0.55543345
5	01/26/2009 08:07:16:237	1.32323567	0.21213335

- The channel numbers and the associated units are shown in the header row.
- If the row limit feature is ON and the data spills over into multiple files, scan numbering continues where it left off in the previous file. Thus, the first scan in the second data file would be number 65,536, the first scan in the third data file would be number 131,071, and so on.

---

## USB Drive Front Panel - 34972A

This section gives information on configuring the USB drive with the front panel. For more information about using the USB drive, see Mass Memory (USB) Subsystem - 34972A, *on page 174*. For more information on the SCPI commands available to configure the USB drive over the remote interface, see the MMEMory Subsystem in the *Agilent 34970A/34972A Programmer's Reference Help*.

### Setting up Automatic Logging

You can set up the USB drive for automatic logging of readings.

*Front-Panel Operation:*

 LOG READINGS AUTO/OFF

### Exporting Readings

You can export readings from reading memory onto the USB drive.





• *Front-Panel Operation:*

 EXPORT READNG YES/NO

## Formatting Readings

You can control how readings are formatted on the USB drive. In particular, you can choose whether the readings are stored in one large file (ROWS/FILE:AUTO) or in a series of files with 64K - 1 rows per file (ROWS/FILE:64K). You can also choose whether the files are formatted with a tab, comma or semicolon between columns.

- *Front-Panel Operation:*

 FORMAT READNG ROWS/FILE:AUTO  
 FORMAT READNG ROWS/FILE:64K  
 FORMAT READNG SEP: TAB  
 FORMAT READNG SEP: COMMA  
 FORMAT READNG SEP: SEMICOLON

## Importing an Instrument Configuration

You can import an instrument configuration stored in an Agilent BenchLink Data Logger configuration (BLCFG) file in the root directory of your USB drive.

- *Front-Panel Operation:*

 IMPORT CONFIG

---

## Remote Interface Configuration - 34970A

This section gives information on configuring the 34970A for remote interface communication. For more information on configuring the instrument from the front panel, see “To Configure the Remote Interface” starting on page 53. For more information on the SCPI commands available to program the instrument over the remote interface, see the *Agilent 34970A/34972A Programmer’s Reference Help*.

### GPIB Address

Each device on the GPIB (IEEE-488) interface must have a unique address. You can set the instrument’s address to any value between 0 and 30. The address is set to “9” when the instrument is shipped from the factory. The GPIB address is displayed at power-on.

*You can set the GPIB address from the front panel only.*

- The address is stored in *non-volatile* memory, and *does not* change when power has been off, after a Factory Reset (\*RST command), or after an Instrument Preset (SYSTem:PRESet command).
- Your computer’s GPIB interface card has its own address. Be sure to avoid using the computer’s address for any instrument on the interface bus. Agilent’s GPIB interface cards generally use address “21”.
- *Front-Panel Operation:*

 ADDRESS 09

## Remote Interface Selection

The 34970A is shipped with both an GPIB (IEEE-488) interface and an RS-232 interface. Only one interface can be enabled at a time. The GPIB interface is selected when the instrument is shipped from the factory.

- The interface selection is stored in *non-volatile* memory, and *does not* change when power has been off, after a Factory Reset (\*RST command), or after an Instrument Preset (SYSTEM:PRESet command).
- If you select the GPIB interface, you must select a unique address for the instrument. The GPIB address is displayed on the front panel when you turn on the instrument.
- If you select the RS-232 interface, you must also set the baud rate, parity, and flow control mode for the instrument. “RS-232” is displayed on the front panel when you turn on the instrument.
- *Front-Panel Operation:*

The image shows a rectangular display area on the front panel. Inside the display, the word "Interface" is enclosed in a rounded rectangle. To its right, the text "GPIB / 488 , RS-232" is displayed.

- *Remote Interface Operation:*  
SYSTEM:INTERface {GPIB|RS232}



## Baud Rate Selection (RS-232)

You can select one of eight baud rates for RS-232 operation. The rate is set to 57,600 baud when the instrument is shipped from the factory.

*You can set the baud rate from the front panel only.*

- Select one of the following: 1200, 2400, 4800, 9600, 19200, 38400, **57600** (factory setting), or 115200 baud.
- The baud rate selection is stored in *non-volatile* memory, and *does not* change when power has been off, after a Factory Reset (\*RST command), or after an Instrument Preset (SYSTEM:PRESet command).
- *Front-Panel Operation:*

 19200 BAUD

4

## Parity Selection (RS-232)

You can select the parity for RS-232 operation. The instrument is configured for no parity with 8 data bits when shipped from the factory.

*You can set the parity from the front panel only.*

- Select one of the following: **None** (8 data bits), Even (7 data bits), or Odd (7 data bits). When you set the parity, you are also indirectly setting the number of data bits.
- The parity selection is stored in *non-volatile* memory, and *does not* change when power has been off, after a Factory Reset (\*RST command), or after an Instrument Preset (SYSTEM:PRESet command).
- *Front-Panel Operation:*

 EVEN, 7 BITS

## Flow Control Selection (RS-232)

You can select one of several *flow control* methods to coordinate the transfer of data between the instrument and your computer or modem. The method that you select will be determined by the flow method used by your computer or modem.

*You can select the flow control method from the front panel only.*

- Select one of the following: None (no flow control), **XON/XOFF** (factory setting), DTR/DSR, RTS/CTS, or Modem.
- *None*: In this mode, data is sent and received over the interface without any flow control used. When using this method, use a slower baud rate (< 9600 baud) and avoid sending more than 128 characters without stopping or reading a response.
- *XON/XOFF*: This mode uses special characters embedded in the data stream to control the flow. If the instrument is addressed to send data, it continues sending data until the “XOFF” character (13H) is received. When the “XON” character (11H) is received, the instrument resumes sending data.
- *DTR/DSR*: In this mode, the instrument monitors the state of the DSR (data set ready) line on the RS-232 connector. When the line goes true, the instrument sends data over the interface. When the line goes false, the instrument stops sending information (typically within six characters). The instrument sets the DTR line false when the input buffer is almost full (approximately 100 characters) and releases the line when space is available again.
- *RTS/CTS*: This mode operates the same as the *DTR/DSR* mode but uses the RTS (request to send) and CTS (clear to send) lines on the RS-232 connector instead. When the CTS line goes true, the instrument sends data over the interface. When the line goes false, the instrument stops sending information (typically within six characters). The instrument sets the RTS line false when the input buffer is almost full (approximately 100 characters) and releases the line when space is available again.

- *Modem*: This mode uses the DTR/DSR and RTS/CTS lines to control the flow of data between the instrument and a modem. When the RS-232 interface is selected, the instrument sets the DTR line true. The DSR line is set true when the modem is on-line. The instrument sets the RTS line true when it is ready to receive data. The modem sets the CTS line true when it is ready to accept data. The instrument sets the RTS line false when the input buffer is almost full (approximately 100 characters) and releases the line when space is available again.
- The flow control selection is stored in *non-volatile* memory, and *does not* change when power has been off, after a Factory Reset (\*RST command), or after an Instrument Preset (SYSTem:PRESet command).
- *Front-Panel Operation*:

 FLOW RTS/CTS

## Remote Interface Configuration - 34972A

This section gives information on configuring the instrument for remote interface communication. For more information on configuring the instrument from the front panel, see “To Configure the Remote Interface” starting on page 53. For more information on the SCPI commands available to program the instrument over the remote interface, see the *Agilent 34970A/34972A Programmer’s Reference Help*.

All of these menu items are accessed under the top-level menu:

 LAN INTERFACE

### Enabling and Disabling LAN Connectivity

You can enable or disable the LAN connectivity. If you are not controlling the instrument via LAN, it is a good idea to disable LAN connectivity in order to prevent others from connecting to your instrument over the LAN.

- *Front-Panel Operation:*

 LAN ENABLED/DISABLED

### Determining the Status of LAN Connectivity

You can determine whether you are connected to the LAN. This menu item simply indicates the status; it does not allow you to connect. If your instrument loses LAN connectivity, it may take up to 30 seconds for the LXI FAULT message to appear.

- *Front-Panel Operation:*

 STAT:CONNECTED/LXI FAULT

## Resetting the LAN

You can reset the instrument's LAN settings to their default values.

- *Front-Panel Operation:*

 RESET LAN: NO/YES

## Enabling and Disabling DHCP

You can enable or disable Dynamic Host Configuration Protocol (DHCP). When DHCP is enabled (factory setting), the instrument will try to obtain an IP address from a DHCP server. If a DHCP server is found, it will assign a dynamic IP address, Subnet Mask, and Default Gateway to the instrument.

If a DHCP server is not found, the instrument uses AutoIP to automatically configure its IP setting in the Automatic Private IP Addressing range (169.254.xxx.xxx).

When DHCP is disabled, the instrument will use the static IP address, Subnet Mask, Default Gateway and DNS Server during power-on.

- *Front-Panel Operation:*

 DHCP ENABLED/DISABLED

## Setting the IP Address

You can set the IP address for your 34972A. This menu option assigns the static IP address for the instrument. You must disable DHCP in order to set this on the front panel.

The static IP address is applied when DHCP is disabled. If DHCP is enabled, DHCP will auto-assign the IP address. This auto-assigned IP address takes precedence over the static IP address assigned with this feature.

- *Front-Panel Operation:*

 IP ADDRESS

## Setting the Subnet Mask

You can set the subnet mask for your LAN connection. This menu option assigns a Subnet Mask for the instrument. The instrument uses the Subnet Mask to determine whether a client IP address is on the same local subnet. You must disable DHCP in order to set this on the front panel.

When a client IP address is on a different subnet, all packets must be sent to the Default Gateway. Contact your network administrator to determine whether subnetting is being used and for the correct Subnet Mask.

- *Front-Panel Operation:*

 SUBNET MASK

## Setting the Default Gateway

You can set the default gateway for your LAN connection. Contact your network administrator to determine whether subnetting is being used and for the correct address. If DHCP is enabled, DHCP will auto-assign the gateway. This auto-assigned gateway takes precedence over the static gateway assigned with this menu option. You must disable DHCP in order to set this on the front panel.

- *Front-Panel Operation:*

 DEF GATEWAY

## Setting the DNS Server

You can set the address of the DNS server for your LAN connection. Contact your network administrator to determine whether DNS is being used and for the correct address. If DHCP is available and enabled, DHCP will auto-assign the DNS address. This auto-assigned DNS address takes precedence over the static DNS address assigned with this menu option. You must disable DHCP in order to set this on the front panel.

- *Front-Panel Operation:*

 DNS SERVER

## Viewing the MAC Address

You can view the MAC address of your 34972A. This address is of the form ##:##:##:##:##:##, where each # is a hexadecimal digit (0-9 or A-F). The LAN relies on every device attached to the network having a unique MAC address. The MAC address for each instrument is set at the factory and cannot be changed.

- *Front-Panel Operation:*

 MAC ADDRESS

## Calibration Overview

This section gives a brief introduction to the calibration features of the instrument and plug-in modules. For a more detailed discussion of the calibration procedures, see chapter 4 in the *34970A/34972A Service Guide*.

## Calibration Security

This feature allows you to enter a security code to prevent accidental or unauthorized calibrations of the instrument. When you first receive your instrument, it is secured. Before you can calibrate the instrument, you must unsecure it by entering the correct security code.

*If you forget your security code, you can disable the security feature by adding a jumper inside the instrument. See the 34970A/34972A Service Guide for more information.*



- The security code is set to either “HP034970” or “AT034972”, depending on the product number, when the instrument is shipped from the factory. The security code is stored in *non-volatile* memory on the mainframe, and *does not* change when power has been off, after a Factory Reset (\*RST command), or after an Instrument Preset (SYSTEM:PRESet command).
- The security code may contain up to 12 alphanumeric characters. The first character *must* be a letter, but the remaining characters can be letters, numbers, or an underscore ( \_ ). You do not have to use all 12 characters but the first character must always be a letter.



**To Unsecure for Calibration** You can unsecure the instrument either from the front panel or over the remote interface. The instrument is secured when shipped from the factory and the security code is set to “HP034970” or “AT034972”, depending on the product number.

- Once you enter a security code, that code must be used for both front-panel and remote operation. For example, if you secure the instrument from the front panel, you must use that same code to unsecure it from the remote interface.
- *Front-Panel Operation:*

 UNSECURE CAL

When you first enter the *Utility* menu, the calibration entries toggle between CAL SECURED and UNSECURE CAL. To unsecure the instrument, select UNSECURE CAL and press  . After entering the correct security code, press  again. When you return to the menu, you will see new choices CAL UNSECURED and SECURE CAL.

**Note:** If you enter the wrong secure code, NO MATCH is displayed and a new choice, EXIT, is shown.

- *Remote Interface Operation:* To unsecure the instrument, send the following command with the correct security code.



```
CAL:SECURE:STATE OFF,HP034970
```

**Calibration Overview**

**To Secure Against Calibration** You can secure the instrument either from the front panel or over the remote interface. The instrument is secured when shipped from the factory and the security code is set to “HP034970” or “AT034972”, depending on the product number.

- Once you enter a security code, that code must be used for both front-panel and remote operation. For example, if you secure the instrument from the front panel, you must use that same code to unsecure it from the remote interface.
- *Front-Panel Operation:*

 SECURE CAL

When you enter the *Utility* menu, the calibration entries toggle between CAL UNSECURED and SECURE CAL. To secure the instrument, select SECURE CAL and press . After entering the desired security code, press  again. When you return to the menu, you will see new choices CAL SECURED and UNSECURE CAL.

- *Remote Interface Operation:* To secure the instrument, send the following command with the desired security code.

```
CAL:SECURE:STATE ON,HP034970
```



**To Change the Security Code** To change the security code, you must first unsecure the instrument, and then enter a new code. Make sure you have read the security code rules described on page 155 before attempting to change the security code.



- *Front-Panel Operation:* To change the security code, first make sure that the instrument is unsecured. Go to the SECURE CAL entry, enter the new security code, and press  (the instrument is now secured with the new code). Changing the code from the front panel also changes the code as seen from the remote interface.
- *Remote Interface Operation:* To change the security code, first unsecure the instrument using the old security code. Then, enter the new code as shown below.

```
CAL:SECURE:STATE OFF, HP034970 Unsecure with old code
CAL:SECURE:CODE ZZ007943      Enter new code
```

## Calibration Message

The instrument allows you to store one message in calibration memory in the mainframe. For example, you can store such information as the date when the last calibration was performed, the date when the next calibration is due, the instrument's serial number, or even the name and phone number of the person to contact for a new calibration.

- You can record a calibration message *only* from the remote interface and *only* when the instrument is unsecured. You can read the message from either the front-panel or over the remote interface. You can read the calibration message whether the instrument is secured or unsecured.
- The calibration message may contain up to 40 characters. From the front panel, you can view 13 characters of the message at a time. Press  to scroll through the text of the message. Press  again to increase the scrolling speed.
- Storing a calibration message will overwrite any message previously stored in memory.
- The calibration message is stored in *non-volatile* memory in the mainframe, and *does not* change when power has been off, after a Factory Reset (\*RST command), or after an Instrument Preset (SYSTEM:PRESet command).
- *Front-Panel Operation:*

  CAL MESSAGE

- *Remote Interface Operation:* To store the calibration message, send the following command.

```
CAL:STRING 'CAL: 06-01-98'
```

**Calibration Overview****Calibration Count**

You can query the instrument to determine how many calibrations have been performed. Note that your instrument was calibrated before it left the factory. When you receive your instrument, be sure to read the count to determine its initial value.

- The calibration count is stored in *non-volatile* memory in the mainframe, and *does not* change when power has been off, after a Factory Reset (\*RST command), or after an Instrument Preset (SYSTem:PRESet command).
- The calibration count increments up to a maximum of 65,535 after which it rolls over to “0”. Since the value increments by one for each calibration point, a complete calibration may increase the value by many counts.
- The calibration count is also incremented with calibrations of the DAC channels on the multifunction module.
- *Front-Panel Operation:*

  CAL COUNT

- *Remote Interface Operation:*

CALibration:COUNT?

## Factory Reset State

The table below shows the state of the instrument after a **FACTORY RESET** from the *Sto/Rcl* menu or \*RST command from the remote interface.

<b>Measurement Configuration</b>	<b>Factory Reset State</b>
Function	DC Volts
Range	Autorange
Resolution	5½ digits
Integration Time	1 PLC
Input Resistance	10 MΩ (fixed for all DCV ranges)
Channel Delay	Automatic Delay
Totalizer Reset Mode	Count Not Reset When Read
Totalizer Edge Detect	Rising Edge
<b>Scanning Operation</b>	<b>Factory Reset State</b>
Scan List	Empty
Reading Memory	All Readings are Cleared
Min, Max, and Average	Not Changed
Scan Trigger Source	Immediate
Scan Interval (used with TRIGger:SOURce TIMer)	10 Seconds
Scan Count	1
Scan Reading Format	Reading Only (No Units, Channel, Time)
Monitor in Progress	Stopped
<b>Mx+B Scaling</b>	<b>Factory Reset State</b>
Gain Factor ("M")	1
Scale Factor ("B")	0
Scale Label	VDC
<b>Alarm Limits</b>	<b>Factory Reset State</b>
Alarm Queue	Not Cleared
Alarm State	Off
HI and LO Alarm Limits	0
Alarm Output	Alarm 1
Alarm Output Configuration	Latched Mode
Alarm Output State	Output Lines are Cleared
Alarm Output Slope	Fail = Low
<b>Module Hardware</b>	<b>Factory Reset State</b>
34901A, 34902A, 34908A	All Channels Open
34903A, 34904A	All Channels Open
34905A, 34906A	Channels s11 and s21 Selected
34907A	Both DIO Ports = Input, Totalizer Count = 0, Both DACs = 0 VDC
<b>System-Related Operations</b>	<b>Factory Reset State</b>
Display State	On
Error Queue	Errors Not Cleared
Stored States	No Change

---

## Instrument Preset State

The table below shows the state of the instrument after a PRESET from the *Sto/Rcl* menu or `SYSTEM:PRESet` command from the remote interface.

<b>Measurement Configuration</b>	<b>Instrument Preset State</b>
Function	No Change
Range	No Change
Resolution	No Change
Advanced Settings	No Change
Totalizer Reset Mode	Count Not Reset When Read
Totalizer Edge Detect	Rising Edge
<b>Scanning Operation</b>	<b>Instrument Preset State</b>
Scan List	No Change
Reading Memory	All Readings are Cleared
Min, Max, and Average	No Change
Scan Interval Source	No Change
Scan Interval	No Change
Scan Count	No Change
Scan Reading Format	No Change
Monitor in Progress	Stopped
<b>Mx+B Scaling</b>	<b>Instrument Preset State</b>
Gain Factor ("M")	No Change
Scale Factor ("B")	No Change
Scale Label	No Change
<b>Alarm Limits</b>	<b>Instrument Preset State</b>
Alarm Queue	No Change
Alarm State	No Change
HI and LO Alarm Limits	No Change
Alarm Output Configuration	No Change
Alarm Output State	Output Lines are Cleared
Alarm Output Slope	No Change
<b>Module Hardware</b>	<b>Instrument Preset State</b>
34901A, 34902A, 34908A	All Channels Open
34903A, 34904A	All Channels Open
34905A, 34906A	Channels <b>s11</b> and <b>s21</b> Selected
34907A	Both DIO Ports = Input, Totalizer Count = 0, Both DACs = 0 VDC
<b>System-Related Operations</b>	<b>Instrument Preset State</b>
Display State	No Change
Error Queue	Errors Not Cleared
Stored States	No Change

## Multiplexer Module Default Settings

The table below shows the default settings for each measurement function on the multiplexer modules. When you configure a channel for a particular function, these are the default settings.

<b>Temperature Measurements</b>	<b>Default Setting</b>
Temperature Units	°C
Integration Time	1 PLC
Display Resolution	0.1°C
Thermocouple Type	Type J
Open T/C Detection	Off
Reference Junction Source	Internal
RTD Type	$\alpha = 0.00385$
RTD Reference Resistance	$R_0 = 100\Omega$
Thermistor Type	5 k $\Omega$
Channel Delay	Automatic Delay
<b>Voltage Measurements</b>	<b>Default Setting</b>
Range	Autorange
Resolution	5½ digits
Integration Time	1 PLC
Input Resistance	10 M $\Omega$ (fixed for all DCV ranges)
AC Low Frequency Filter	20 Hz (medium)
Channel Delay	Automatic Delay
<b>Resistance Measurements</b>	<b>Default Setting</b>
Range	Autorange
Resolution	5½ digits
Integration Time	1 PLC
Offset Compensation	Off
Channel Delay	Automatic Delay
<b>Frequency/Period Measurements</b>	<b>Default Setting</b>
Range	Autorange
Resolution	5½ digits (frequency), 6½ digits (period)
AC Low Frequency Filter	20 Hz (medium)
Channel Delay	Automatic Delay
<b>Current Measurements</b>	<b>Default Setting</b>
Range	Autorange
Resolution	5½ digits
Integration Time	1 PLC
AC Low Frequency Filter	20 Hz (medium)
Channel Delay	Automatic Delay

---

## Module Overview

This section gives a description of each plug-in module, including simplified schematics and block diagrams. A wiring log is also included to make it easy to document your wiring configuration for each module.

*For complete specifications on each plug-in module, refer to the module sections in chapter 8.*

- 34901A 20-Channel Multiplexer, *on page 201*
- 34902A 16-Channel Multiplexer, *on page 203*
- 34903A 20-Channel Actuator, *on page 205*
- 34904A 4x8 Matrix Switch, *on page 207*
- 34905A/6A Dual 4-Channel RF Multiplexers, *on page 209*
- 34907A Multifunction Module, *on page 211*
- 34908A 40-Channel Single-Ended Multiplexer, *on page 213*



## 34901A 20-Channel Multiplexer

This module is divided into two banks of 10 channels each. Two additional fused channels are available for making direct, calibrated DC or AC current measurements with the internal DMM (external shunts are not required). All 22 channels switch both HI and LO inputs, thus providing fully isolated inputs to the internal DMM or an external instrument. When making 4-wire resistance measurements, the instrument automatically pairs channel  $n$  with channel  $n+10$  to provide the source and sense connections. The module has a built-in thermocouple reference junction to minimize errors due to thermal gradients when measuring thermocouples.

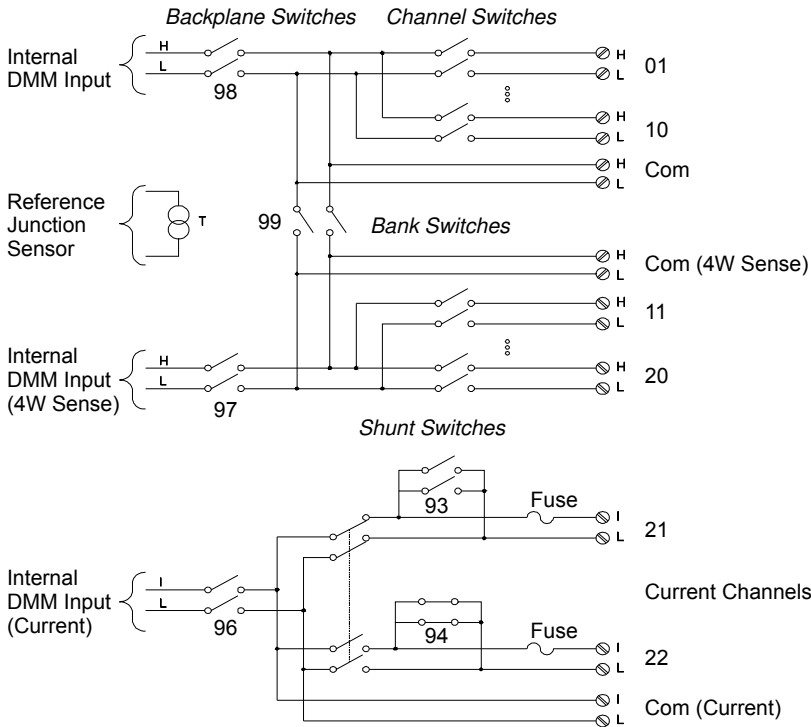

**NOTES:**

- Only one of channels 21 and 22 can be connected to the internal DMM and/or Com at a time; connecting one channel will close the other (thus shorting the input "I" to "LO").
- If any channels are configured to be part of the scan list, you cannot close multiple channels; closing one channel will open the previously closed channel.
- Connections to AC line are not recommended unless you provide external transient suppression.

Chapter 4 Features and Functions  
**34901A 20-Channel Multiplexer**

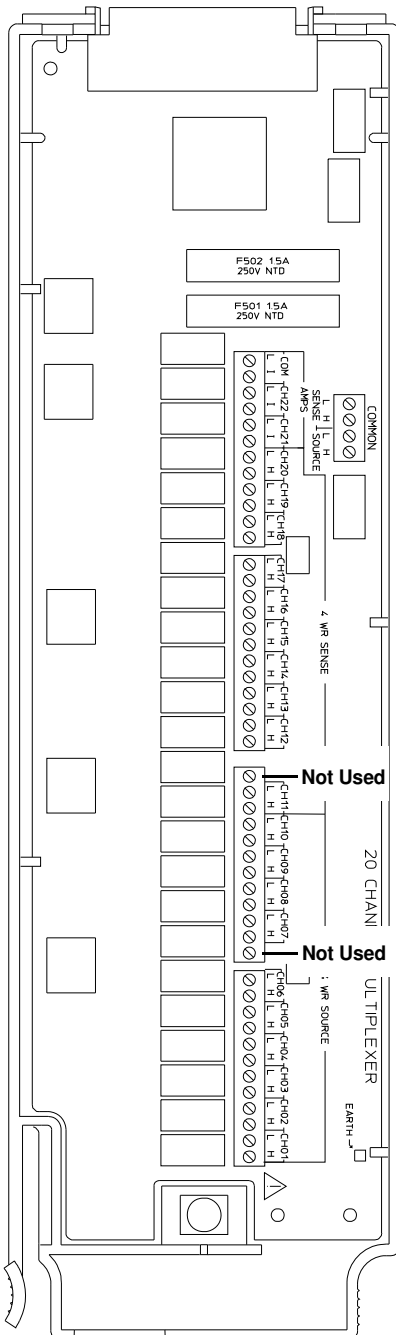

**WIRING LOG**

Slot Number: 100 200 300

Ch	Name	Function	Comments
01			
02			
03			
04			
05			
06			
07			
08			
09			
10			
H COM			
L COM			
11*			
12*			
13*			
14*			
15*			
16*			
17*			
18*			
19*			
20*			
H COM			
L COM			
<i>Current Channels Only:</i>			
21			
22			
I COM			
L COM			

\*4W Sense Channels are paired to Channel (n-10).

Refer to the diagrams on page 27 to connect wiring to the module.

Maximum Input Voltage: 300 V (CAT 1)

Maximum Input Current: 1 A

Maximum Switching Power: 50 W

20 AWG Typical

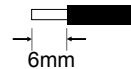

**⚠ WARNING:** To prevent electrical shock, use only wire that is rated for the highest voltage applied to any channel. Before removing a module cover, turn off all power to external devices connected to the module.

## 34902A 16-Channel Multiplexer

This module is divided into two banks of eight channels each. All 16 channels switch both HI and LO inputs, thus providing fully isolated inputs to the internal DMM or an external instrument. When making 4-wire resistance measurements, the instrument automatically pairs channel  $n$  with channel  $n+8$  to provide the source and sense connections. The module has a built-in thermocouple reference junction to minimize errors due to thermal gradients when measuring thermocouples.

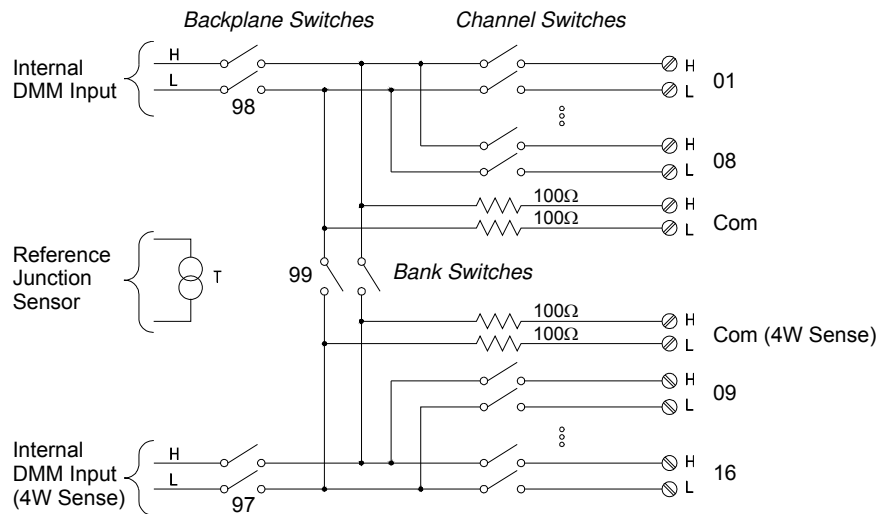

### NOTES:

- If any channels are configured to be part of the scan list, you cannot close multiple channels; closing one channel will open the previously closed channel.
- Current measurements on this module will require external shunt resistors.
- Connections to AC line are not recommended unless you provide external transient suppression.

Chapter 4 Features and Functions  
**34902A 16-Channel Multiplexer**

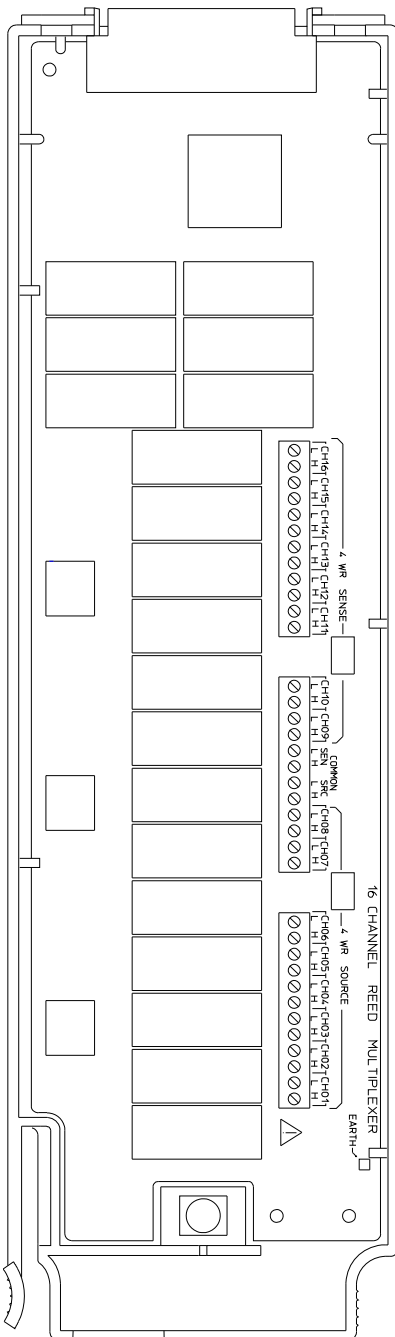

**WIRING LOG**

Slot Number: 100 200 300

Ch	Name	Function	Comments
01			
02			
03			
04			
05			
06			
07			
08			
H COM			
L COM			
09*			
10*			
11*			
12*			
13*			
14*			
15*			
16*			
H COM			
L COM			

\*4W Sense Channels are paired to Channel (n-8).

Refer to the diagrams on page 27 to connect wiring to the module.

Maximum Input Voltage: 300 V (CAT 1)

Maximum Input Current: 50 mA

Maximum Switching Power: 2 W

20 AWG Typical

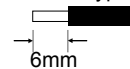

**⚠ WARNING:** To prevent electrical shock, use only wire that is rated for the highest voltage applied to any channel. Before removing a module cover, turn off all power to external devices connected to the module.

---

## 34903A 20-Channel Actuator

This module contains 20 independent, SPDT (Form C) latching relays. Screw terminals on the module provide access to the Normally-Open, Normally-Closed, and Common contacts for each switch. This module *does not* connect to the internal DMM.

A breadboard area is provided near the screw terminals to implement custom circuitry, such as simple filters, snubbers, and voltage dividers. The breadboard area provides the space necessary to insert your own components but there are no circuit board traces here. You must add your own circuitry and signal routing.

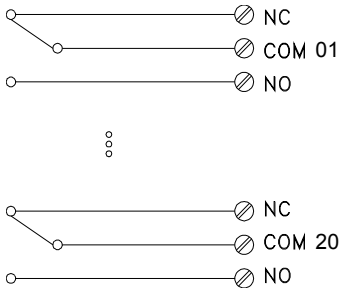

**NOTES:**

- You can close multiple channels at the same time on this module.
- The channel CLOSE and OPEN commands control the state of the Normally Open (NO) to COM connection on each channel. For example, CLOSE 201 connects the Normally Open contact to COM on channel 01.

Chapter 4 Features and Functions  
**34903A 20-Channel Actuator**

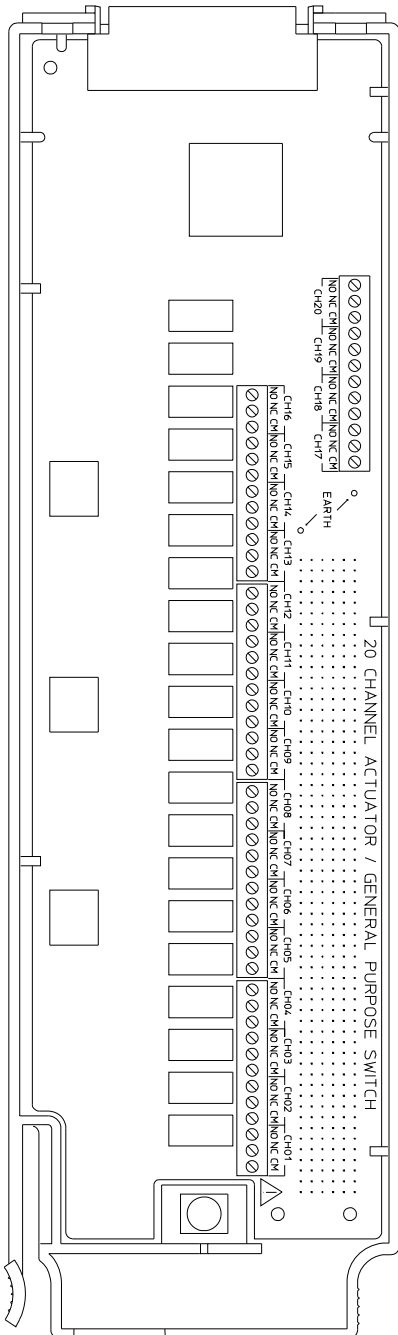

**WIRING LOG**

Slot Number: 100 200 300

Ch	NO	NC	COM	Comments
01				
02				
03				
04				
05				
06				
07				
08				
09				
10				
11				
12				
13				
14				
15				
16				
17				
18				
19				
20				

**NO** = Normally Open, **NC** = Normally Closed

Refer to the diagrams on page 27 to connect wiring to the module.

Maximum Input Voltage: 300 V (CAT 1)

Maximum Input Current: 1 A

Maximum Switching Power: 50 W

20 AWG Typical

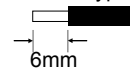

**⚠ WARNING:** To prevent electrical shock, use only wire that is rated for the highest voltage applied to any channel. Before removing a module cover, turn off all power to external devices connected to the module.

### 34904A 4x8 Matrix Switch

This module contains 32 two-wire crosspoints organized in a 4-row by 8-column configuration. You can connect any combination of inputs and outputs at the same time. This module does not connect to the internal DMM. Each crosspoint relay has its own unique channel label representing the row and column. For example, channel 32 represents the crosspoint connection between row 3 and column 2 as shown below.

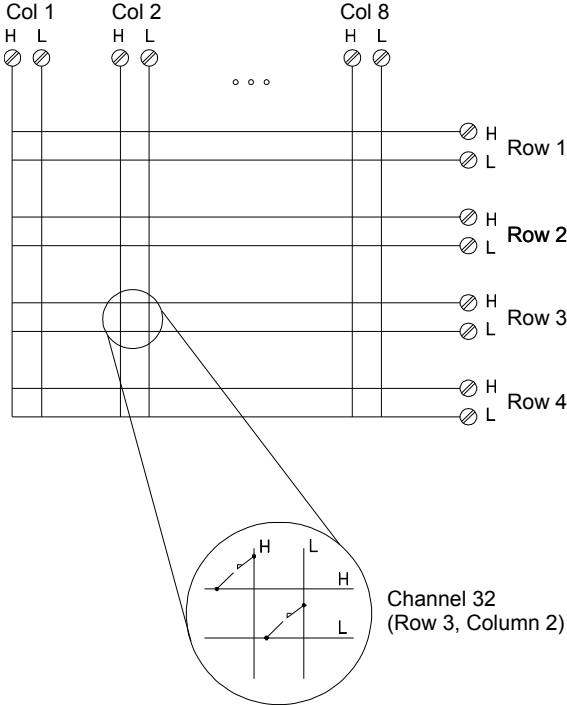

**NOTES:**

- You can close multiple channels at the same time on this module.

Chapter 4 Features and Functions  
**34904A 4x8 Matrix Switch**

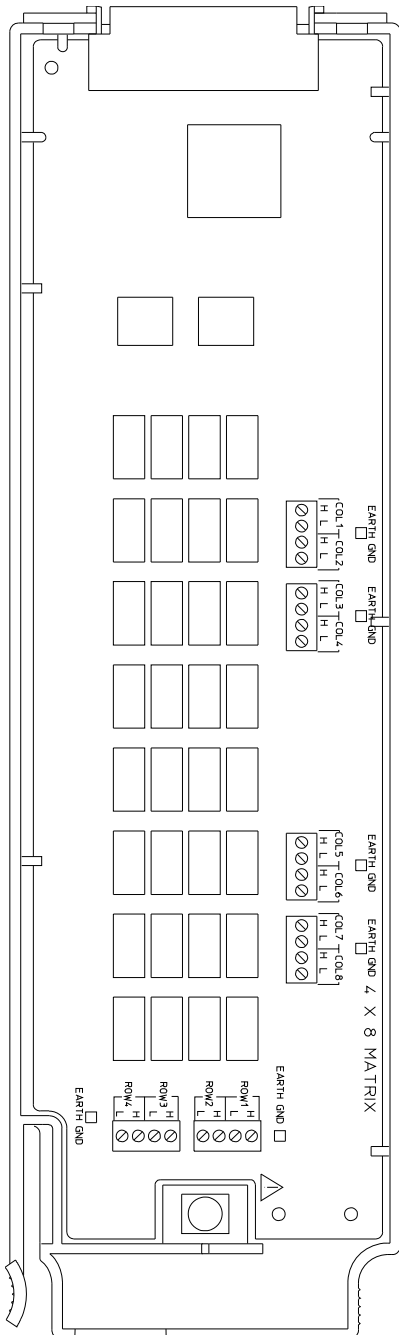

**WIRING LOG**

Slot Number: 100 200 300

Row	Name	Comments
1		
2		
3		
4		

Column	Name	Comments
1		
2		
3		
4		
5		
6		
7		
8		

Example: Channel 32 represents Row 3 and Column 2.

Refer to the diagrams on page 27 to connect wiring to the module.

Maximum Input Voltage: 300 V (CAT 1)

Maximum Input Current: 1 A

Maximum Switching Power: 50 W

20 AWG Typical

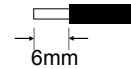

**⚠ WARNING:** To prevent electrical shock, use only wire that is rated for the highest voltage applied to any channel. Before removing a module cover, turn off all power to external devices connected to the module.



## 34905A/6A Dual 4-Channel RF Multiplexers

These modules consist of two independent 4-to-1 multiplexers. The channels in each bank are organized in a “tree” structure to provide high isolation and low VSWR. Both banks have a common earth ground. This module *does not* connect to the internal DMM. You can connect your signals directly to the on-board SMB connectors or to the SMB-to-BNC cables provided with the module.

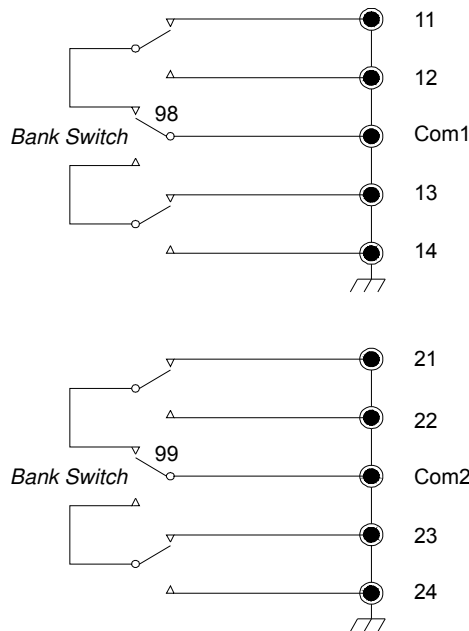

### NOTES:

- The 34905A is used for 50Ω applications. The 34906A is used for 75Ω applications (mini SMBs).
- You can close only one channel per bank at a time on these modules; closing one channel in a bank will open the previously closed channel. One channel in each bank is always connected to COM.
- This module responds only to the CLOSE command (OPEN does not apply). To OPEN a channel, send the CLOSE command to another channel in the same bank.

Chapter 4 Features and Functions  
**34905A/6A Dual 4-Channel RF Multiplexers**

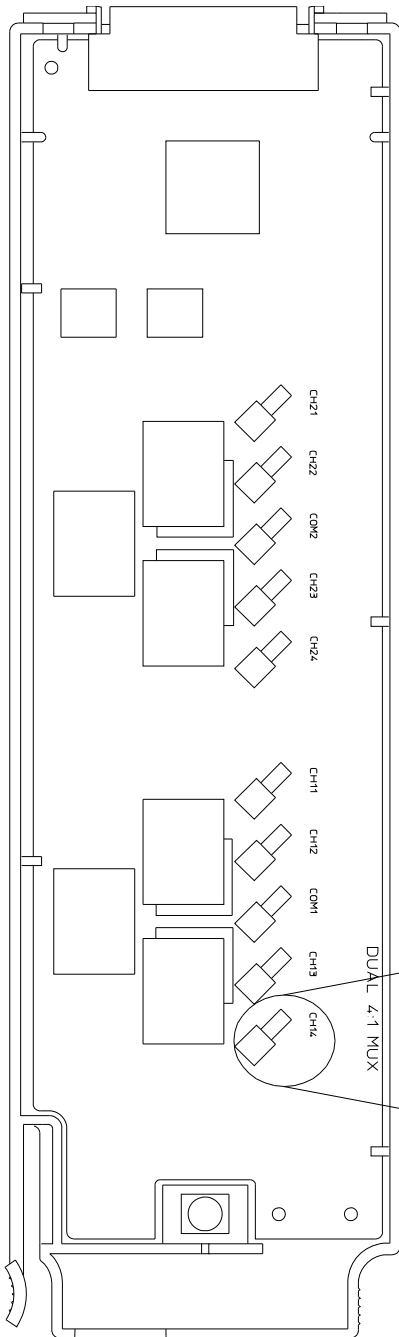

**WIRING LOG**

Slot Number: 100 200 300

Ch	Name	Comments
11		
12		
13		
14		
COM1		
21		
22		
23		
24		
COM2		

*Refer to the diagrams on page 27 to connect wiring to the module.*

Maximum Input Voltage: 42 V

Maximum Input Current: 700 mA

Maximum Switching Power: 20 W

Ten color-coded cables are included with the module. To order additional cables, use the following cable kit part numbers (10 cables are included):

**34905-60001 (50Ω cables)**

**34906-60001 (75Ω cables)**

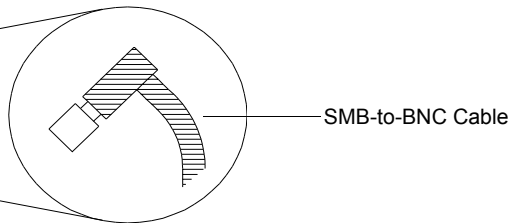

## 34907A Multifunction Module

This module combines two 8-bit ports of digital input/output, a 100 kHz totalizer, and two  $\pm 12V$  analog outputs. For greater flexibility, you can read digital inputs and the totalizer count during a scan.

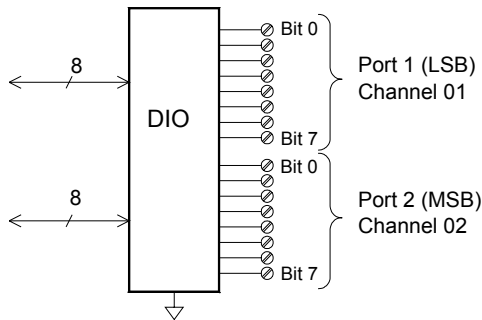

### Digital Input/Output

The DIO consists of two 8-bit ports with TTL-compatible inputs and output. The open-drain outputs can sink up to 400 mA. From the front panel, you can read data from only one 8-bit input port at a time. From the remote interface, you can read both ports simultaneously as a 16-bit word *only* if neither port is in the scan list.

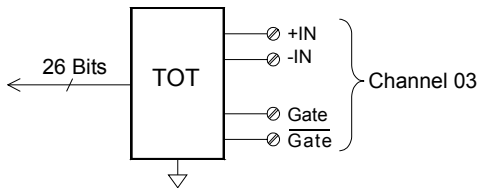

### Totalize Input

The 26-bit totalizer can count pulses at a 100 kHz rate. You can configure the totalizer to count on the rising edge or falling edge of the input signal. A TTL high signal applied to the “G” terminal enables counting and a low signal disables counting. A TTL low signal applied to the “ $\bar{G}$ ” terminal enables counting and a high signal disables counting. The totalizer only counts when both terminals are enabled. Move the *Totalize Threshold* jumper to the “AC” position to detect changes through 0 volts. Move the jumper to the “TTL” position (factory setting) to detect changes through TTL threshold levels.

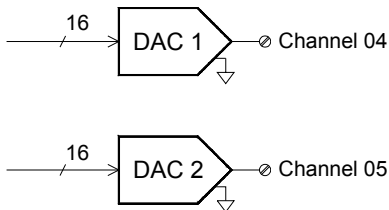

### Analog Output (DAC)

The two analog outputs are capable of outputting calibrated voltages between  $\pm 12$  volts with 16 bits of resolution. Each DAC channel is capable of 10 mA maximum current. You must limit the DAC output current to 40 mA total for all three slots (six DAC channels).

Chapter 4 Features and Functions  
**34907A Multifunction Module**

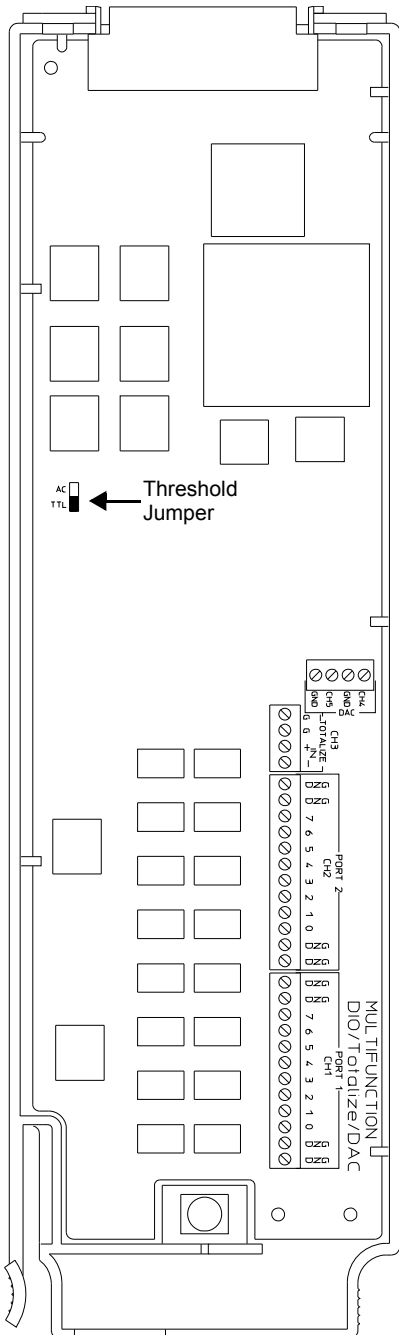

**WIRING LOG**

Slot Number: 100 200 300

Ch	Name	Comments
01 (DIO 1)	Bit 0	
	Bit 1	
	Bit 2	
	Bit 3	
	Bit 4	
	Bit 5	
	Bit 6	
	Bit 7	
02 (DIO 2)	GND	
	Bit 0	
	Bit 1	
	Bit 2	
	Bit 3	
	Bit 4	
	Bit 5	
	Bit 6	
03 (Totalizer)	Bit 7	
	GND	
	Input (+)	
	Input (-)	
04 (DAC 1)	Gate	
	Gate	
	Output	
05 (DAC 2)	GND	
	Output	

Threshold Jumper Position: TTL AC

Refer to the diagrams on page 27 to connect wiring to the module.

**Digital Input/Output:**

- Vin (L): < 0.8V (TTL)
- Vin (H): >2.0V (TTL)
- Vout (L): <0.8V @ Iout = -400 mA
- Vout (H): >2.4V @ Iout = 1 mA
- Vin(H) Max: <42V with external open-drain pull-up

20 AWG Typical

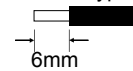

**Totalizer:**

- Maximum Count: 67,108,863 ( $2^{26} - 1$ )
- Totalize Input: 100 kHz (max)
- Signal Level: 1 Vp-p (min), 42 Vpk (max)

**DAC Output:**

- ±12V, non-isolated
- Iout: 10 mA max per DAC; 40 mA max per mainframe

## 34908A 40-Channel Single-Ended Multiplexer

The module is divided into two banks of 20 channels each. All of the 40 channels switch HI only, with a common LO for the module. The module has a built-in thermocouple reference junction to minimize errors due to thermal gradients when measuring thermocouples.

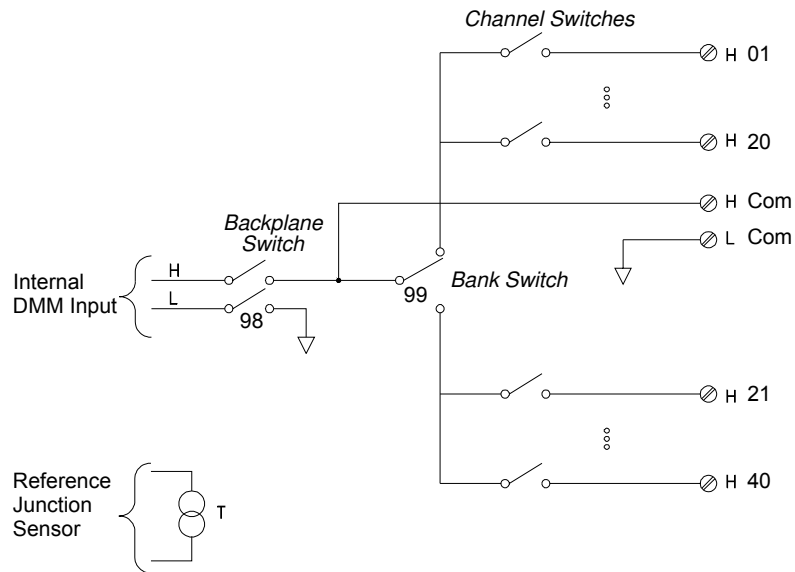

### NOTES:

- Refer to the diagrams on page 27 to connect wiring to the module.
- Only one channel can be closed at a time; closing one channel will open the previously closed channel.
- This module cannot be used to directly measure current or any 4-wire measurements.
- When connecting thermocouples to the screw terminals on this module (not recommended due to the common LO configuration), be sure to provide electrical isolation between thermocouples to avoid current loops and subsequent measurement errors.
- Connections to AC line are not recommended unless you provide external transient

Maximum Input Voltage: 300 V (CAT I)  
 Maximum Input Current: 1 A  
 Maximum Switching Power: 50 W

20 AWG Typical



**⚠ WARNING:** To prevent electrical shock, use only wire that is rated for the highest voltage applied to any channel. Before removing a module cover, turn off all power to external devices connected to the module.

Chapter 4 Features and Functions  
**34908A 40-Channel Single-Ended Multiplexer**

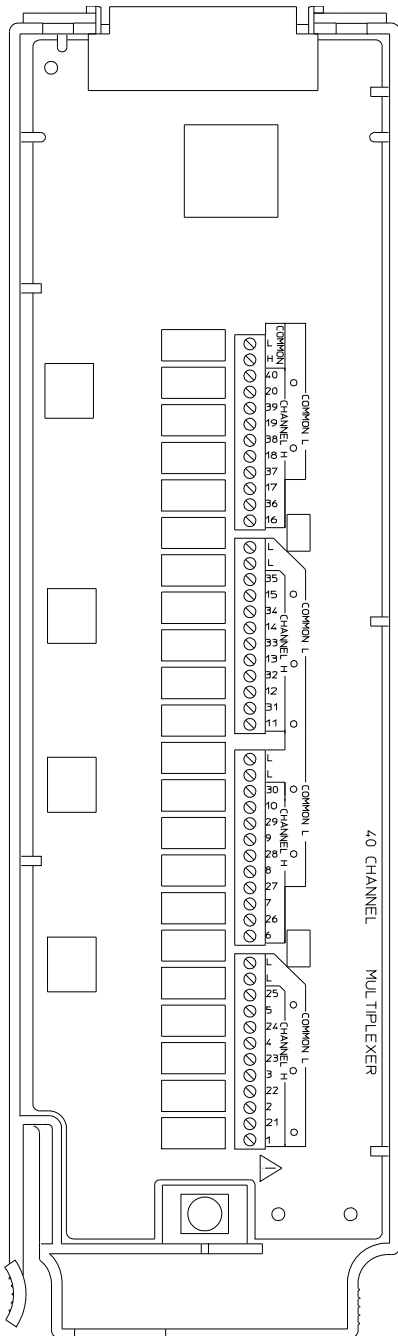

**WIRING LOG**

Slot Number: 100 200 300

Ch	Name	Function	Comments
01			
02			
03			
04			
05			
06			
07			
08			
09			
10			
11			
12			
13			
14			
15			
16			
17			
18			
19			
20			
21			
22			
23			
24			
25			
26			
27			
28			
29			
30			
31			
32			
33			
34			
35			
36			
37			
38			
39			
40			
LO			
H COM			
L COM			







---



## Error Messages

---

# Error Messages

- Errors are retrieved in first-in-first-out (FIFO) order. The first error returned is the first error that was stored. Errors are cleared as you read them. When you have read all errors from the queue, the **ERROR** annunciator turns off and the errors are cleared. The instrument beeps once each time an error is generated.
- If more than 10 errors (34970A) or 20 errors (34972A) have occurred, the last error stored in the queue (the most recent error) is replaced with “*Error queue overflow*”. No additional errors are stored until you remove errors from the queue. If no errors have occurred when you read the error queue, the instrument responds with “*No error*”.
- The error queue is cleared by the \*CLS (clear status) command or when power is cycled. The errors are also cleared when you read the queue. The error queue *is not* cleared by a Factory Reset (\*RST command) or an Instrument Preset (SYSTEM:PRESet command).
- *Front-Panel Operation:*

 ERRORS

If the **ERROR** annunciator is on, press  to view the errors. Use the knob to scroll through the error numbers. Press  to view the text of the error message. Press  again to increase the scrolling speed (the final key press cancels the scroll). All errors are cleared when you exit the menu.

- *Remote Interface Operation:*

SYSTEM:ERROR?      *Read and clear one error from the queue*

Errors have the following format (the error string may contain up to 80 characters):

```
-113, "Undefined header"
```

---

## Execution Errors

- 101 Invalid character**  
An invalid character was found in the command string. You may have used an invalid character such as #, {, \$, or % in the command header or within a parameter. *Example:* CONF:VOLT:DC {@101}
- 102 Syntax error**  
Invalid syntax was found in the command string. You may have inserted a blank space before or after a colon in the command header, or before a comma. Or you may have omitted the “@” character in the channel list syntax. *Examples:* ROUT:CHAN: DELAY 1 or CONF:VOLT:DC ( 101)
- 103 Invalid separator**  
An invalid separator was found in the command string. You may have used a comma instead of a colon, semicolon, or blank space – or you may have used a blank space instead of a comma. *Examples:* TRIG:COUNT, 1 or CONF:FREQ 1000 0.1
- 105 GET not allowed**  
A Group Execute Trigger (GET) is not allowed within a command string.
- 108 Parameter not allowed**  
More parameters were received than expected for this command. You may have entered an extra parameter or added a parameter to a command that does not require a parameter. *Example:* READ? 10
- 109 Missing parameter**  
Fewer parameters were received than expected for this command. You have omitted one or more parameters that are required for this command. *Example:* ROUT:CHAN:DELAY
- 112 Program mnemonic too long**  
A command header was received which contained more than the maximum 12 characters allowed. *Example:* CONFIGURATION:VOLT:DC
- 113 Undefined header**  
A command was received that is not valid for this instrument. You may have misspelled the command or it may not be a valid command. If you are using the shortened form of this command, remember that it may contain up to four letters. Or you may have inserted an extra colon where one is not required. *Examples:* TRIGG:COUN 3 or CONF:VOLT:DC: (@101)

**Execution Errors**

- 114 Header suffix out of range**  
A header suffix is the number that can be appended to the end of some command headers. This error is generated if an invalid number is used.  
*Example:* `OUTP:ALARM5:SOURCE` (“5” is not a valid alarm number)
- 121 Invalid character in number**  
An invalid character was found in the number specified for a parameter.  
*Example:* `TRIG:TIMER 12..34`
- 123 Numeric overflow**  
A numeric parameter was found whose exponent was too large for this command. *Example:* `CALC:SCALE:GAIN 1E34000`
- 124 Too many digits**  
A numeric parameter was found whose mantissa contained more than 255 digits, excluding leading zeros.
- 128 Numeric data not allowed**  
The wrong parameter type was found in the command string. You may have specified a number where a string or expression was expected, or vice versa. *Examples:* `DISP:TEXT 5.0` or `ROUT:CLOSE 101`
- 131 Invalid suffix**  
A suffix was incorrectly specified for a numeric parameter. You may have misspelled the suffix. *Example:* `ROUT:CHAN:DELAY 5 SECS`
- 134 Suffix too long**  
A header suffix is the number that can be appended to the end of some command headers. This error is generated if the header suffix contains more than 12 characters.
- 138 Suffix not allowed**  
A parameter suffix was specified when one was not allowed.

- 148**                    **Character data not allowed**  
A discrete parameter was received but a character string or a numeric parameter was expected. Check the list of parameters to verify that you have used a valid parameter type. *Examples:* ROUTE:CLOSE CH101 or DISP:TEXT TESTING (the string must be enclosed in quotes)
- 151**                    **Invalid string data**  
An invalid character string was received. Check to see if you have enclosed the character string in quotation marks and verify that the string contains valid ASCII characters. *Example:* DISP:TEXT ' TESTING (the ending quote is missing)
- 158**                    **String data not allowed**  
A character string was received but is not allowed for this command. Check the list of parameters to verify that you have used a valid parameter type. *Example:* CALC:SCALE:STATE 'ON'
- 168**                    **Block data not allowed**  
Data was sent to the instrument in SCPI *definite length block* format but this command does not accept this format.  
*Example:* SOUR:DIG:DATA #128
- 178**                    **Expression data not allowed**  
A channel list was received but is not allowed for this command.  
*Example:* SYST:CTYPE? (@100)
- 211**                    **Trigger ignored**  
More than one trigger was received while the instrument was scanning. Triggers are occurring too frequently and you may need to slow them down. Also make sure that you have selected the proper trigger source.
- 213**                    **INIT ignored**  
An INITiate command was received but could not be executed because a scan was already in progress. Send an ABORT command or bus Device Clear to stop a scan in progress.

**Execution Errors**

- 214**            **Trigger deadlock**  
A trigger deadlock occurs when the trigger source is "BUS" and a READ? command is received.
- 221**            **Settings conflict**  
An invalid configuration was requested. This error is most commonly generated when setting alarm limits. Note that the lower limit must always be less than or equal to the upper limit, even if you are using only one of the limits. This error is also generated if you send the MEASure? or CONFigure command with autorange enabled with a fixed resolution.
- 222**            **Data out of range**  
A numeric parameter value is outside the valid range for this command.  
*Example:* TRIG:COUNT -3
- 223**            **Too much data**  
A character string was received but could not be executed because the string length was more than 12 characters. This error can be generated by the CAL:STRing and DISPlay:TEXT commands.
- 224**            **Illegal parameter value**  
A discrete parameter was received which was not a valid choice for this command. You may have used an invalid parameter choice.  
*Example:* TRIG:SOURCE ALARM (ALARM is not a valid choice)
- 230**            **Data stale**  
A FETCh? or DATA:REMOve? command was received but internal reading memory was empty. The readings retrieved may be invalid.
- 310**            **System error**  
A firmware defect has been found. *This is not a fatal error but you should contact your nearest Agilent Service Center if this error is reported.*

- 350 Error queue overflow**  
The error queue is full because more than 10 errors (34970A) or 20 errors (34972A) have occurred. No additional errors are stored until you remove errors from the queue. The error queue is cleared by the \*CLS (clear status) command or when power is cycled. The errors are also cleared when you read the queue.
- 410 Query INTERRUPTED**  
A command was received which sends data to the output buffer, but the output buffer contained data from a previous command (the previous data is not overwritten). The output buffer is cleared when power has been off or after a bus Device Clear.
- 420 Query UNTERMINATED**  
The instrument was addressed to talk (i.e., send data over the interface) but a command has not been received which sends data to the output buffer. For example, you may have executed a CONFigure command (which does not generate data) and then attempted to read data from the remote interface.
- 430 Query DEADLOCKED**  
A command was received which generates too much data to fit in the output buffer and the input buffer is also full. Command execution continues but all data is lost.
- 440 Query UNTERMINATED after indefinite response**  
The \*IDN? command must be the last query command within a command string. The \*IDN? command returns an indefinite length string which cannot be combined with any other query command.  
*Example: \*IDN?; \*STB?*

## Instrument Errors

- 111 Channel list: slot number out of range**  
The specified slot number is invalid. The channel number has the form (@*scc*), where *s* is the slot number (100, 200, or 300) and *cc* is the channel number. *Example:* CONF:VOLT:DC (@404)
- 112 Channel list: channel number out of range**  
The specified channel number is invalid for the module in the selected slot. The channel number has the form (@*scc*), where *s* is the slot number (100, 200, or 300) and *cc* is the channel number. *Example:* ROUT:CLOSE (@134)
- 113 Channel list: empty scan list**  
Before you can initiate a scan, you must set up a scan list which includes all configured multiplexer or digital channels in the instrument. Use the MEASure?, CONFIgure, or ROUTe:SCAN commands to set up your scan list.
- 201 Memory lost: stored state**  
This error is reported at power-on to indicate that a stored state has become unusable. This error is most likely caused by a dead battery (memory is battery-backed). *Refer to the 34970A/34972A Service Guide to replace the internal battery.*
- 202 Memory lost: power-on state**  
This error is reported at power-on to indicate that the power-down state of the instrument (normally recalled when power is turned on) has become unusable. This error is most likely caused by a dead battery (memory is battery-backed). *Refer to the 34970A/34972A Service Guide to replace the internal battery.*



- 203**                    **Memory lost: stored readings**  
This error is reported at power-on to indicate that readings stored in memory from a previous scan have been lost. This error is most likely caused by a dead battery (memory is battery-backed). *Refer to the 34970A/34972A Service Guide to replace the internal battery.*
- 204**                    **Memory lost: time and date**  
This error is reported at power-on to indicate that the time and date settings have been lost (they are reset to JAN 1, 1996 00:00:00). This error is most likely caused by a dead battery (memory is battery-backed). *Refer to the 34970A/34972A Service Guide to replace the internal battery.*
- 221**                    **Settings conflict: calculate limit state forced off**  
If you plan to use scaling on a channel which will also use alarms, *be sure to configure the scaling values first.* This error is generated if you attempt to assign the alarm limits first and the instrument will turn off alarms and clear the limit values.
- 222**                    **Settings conflict: module type does not match stored state**  
Before recalling a stored state, the instrument verifies that the same module types are installed in each slot. The instrument has detected a different module type in one or more slots.
- 223**                    **Settings conflict: trig source changed to IMM**  
This error is generated if you attempt to set the channel advance source (ROUTE:CHAN:ADVance:SOURce command) to the same source used for the scan trigger (TRIGger:SOURce command). The command has been accepted and executed but the scan trigger source is reset to "IMMEDIATE".
- 224**                    **Settings conflict: chan adv source changed to IMM**  
This error is generated if you attempt to set the scan trigger source (TRIGger:SOURce command) to the same source used for the channel advance source (ROUTE:CHAN:ADVance:SOURce command). The command has been accepted and executed but the channel advance source is reset to "IMMEDIATE".

**Instrument Errors**

- 225**            **Settings conflict: DMM disabled or missing**  
This command is valid only when the internal DMM is installed and enabled. Use the `INSTRUMENT:DMM?` command to determine the state of the internal DMM. *For more information, see “Internal DMM Disable” on page 167.*
- 226**            **Settings conflict: DMM enabled**  
When the internal DMM is enabled, the `ROUTE:CHAN:ADVance:SOURce` and `ROUTE:CHAN:FWIRe` commands *are not* allowed. Use the `INSTRUMENT:DMM?` command to determine the state of the internal DMM. *For more information, see “Internal DMM Disable” on page 167.*
- 251**            **Unsupported temperature transducer type**  
An invalid RTD or thermistor type has been specified. The following RTDs are supported:  $\alpha = 0.00385$  (“85”) and  $\alpha = 0.00391$  (“91”). The following thermistors are supported: 2.2 k $\Omega$  (“2252”), 5 k $\Omega$  (“5000”), and 10 k $\Omega$  (“10000”). *Example:* `CONF:TEMP RTD,1,(@101)`
- 261**            **Not able to execute while scan initiated**  
While a scan is running, you cannot change any parameters that affect the scan (channel configuration, scan interval, scaling values, alarm limits, issue a Card Reset, or recall a stored state). To stop a scan in progress, send the `ABORt` command or a bus Device Clear.
- 271**            **Not able to accept unit names longer than 3 characters**  
For `Mx+B` scaling, you can specify a custom label with up to three characters. You can use letters (A-Z), numbers (0-9), an underscore ( \_ ), or the “#” character which displays a degree symbol ( ° ) on the front panel.
- 272**            **Not able to accept character in unit name**  
For `Mx+B` scaling, you can specify a custom label with up to three characters. The first character must be a letter or the “#” character (the “#” character is allowed only as the leftmost character in the label). The remaining two characters can be letters, numbers, or an underscore.

- 281**                    **Not able to perform on more than one channel**  
You can perform this operation on only one channel at a time. Check the channel list that you sent with this command to see if it contains more than one channel. This error is generated by the `ROUTE:MON` and `DATA:LAST?` commands.
- 291**                    **Not able to recall state: it is empty**  
You can only recall a state from a location that contains a previously stored state. The state location that you attempted to recall is empty. The storage locations are numbered 0 through 5.
- 292**                    **Not able to recall state: DMM enable changed**  
The enable/disable state of the internal DMM has been changed since the instrument state was stored. Use the `INSTRUMENT:DMM?` command to determine the state of the internal DMM. *For more information, see “Internal DMM Disable” on page 167.*
- 301**                    **Module currently committed to scan**  
When you add a multiplexer channel to a scan list, that entire module is dedicated to the scan. You cannot perform low-level close or open operations on any channels on that module (even those channels that are not configured). To stop a scan in progress, send the `ABORT` command or a bus Device Clear.
- 303**                    **Module not able to perform requested operation**  
A command was received which is not valid for the specified module. This error is most commonly generated when you send a command intended for the multifunction module to a switching module.
- 305**                    **Not able to perform requested operation**  
The requested operation is not valid for the specified channel. You may have tried to a configure a channel for current measurements (valid only on channels 21 and 22 on the 34901A module). Or you may have tried to configure scaling on a module that does not connect to the internal DMM.

**Instrument Errors**

**306**

**Part of a 4-wire pair**

For 4-wire resistance measurements, the instrument automatically pairs channel  $n$  with channel  $n+10$  (34901A) or  $n+8$  (34902A) to provide the source and sense connections. To change the configuration on the upper channel in a 4-wire pair, you must first reconfigure the lower channel to a measurement function other than 4-wire resistance.

**307**

**Incorrectly configured ref channel**

For thermocouple measurements using an external reference, the instrument automatically reserves channel 01 on the multiplexer in the *lowest* slot as the reference channel. Before configuring a thermocouple channel with an external reference, you must configure the reference channel (channel 01) for a *thermistor or RTD* measurement.

This error is also generated if you change the function on the reference channel (channel 01) after selecting the external reference source on a thermocouple channel.

**308**

**Channel not able to perform requested operation**

The channel is unable to perform the requested operation.

**309**

**Incorrectly formatted channel list**

The channel list is not formatted correctly. Examples of proper formats are shown below.

(@321) - channel 21 on the module in slot 300.

(@221:222) - channels 21 through 22 on the module in slot 200.

(@121:122,222,321:322) - channels 21 and 22 on the module in slot 100, channel 22 on the module in slot 200, and channels 21-22 on the module in slot 300.

- 401           **Mass storage error: failed to create file**  
The file was not created on the USB drive.
- 402           **Mass storage error: failed to open file**  
The file was not opened on the USB drive.
- 403           **Mass storage error: failed to close file**  
The file was not closed on the USB drive.
- 404           **Mass storage error: file write error**  
The file data was not written on the USB drive.
- 405           **Mass storage error: file read error**  
File data was not read from the USB drive.
- 406           **Mass storage error: file write error**  
File data was not flushed to the USB drive.
- 407           **Mass storage error: failed to remove file**  
The instrument was unable unable to delete the file on the USB drive.
- 408           **Mass storage error: failed to create directory**  
The instrument was unable to create the directory on the USB drive.
- 409           **Mass storage error: failed to remove directory**  
The instrument was unable to remove the directory on the USB drive.
- 410           **Not enough disk space**  
The external USB drive is full.
- 411           **No external disk detected**  
The operation requires a USB drive, which is not detected.
- 412           **External disk has been detached**  
The external USB drive has been unplugged.
- 413           **File already exists**  
The instrument was unable to create new file because a file with that name already exists on the USB drive.

**Instrument Errors**

- 414** Directory already exists  
The instrument was unable to create new directory because a directory with that name already exists on the USB drive.
- 415** File not found  
The file does not exist on the USB drive.
- 416** Path not found  
The directory does not exist on the USB drive.
- 417** File not opened for writing  
The instrument failed to open the file for writing on the USB drive.
- 418** File not opened for reading  
The instrument failed to open the file for reading from the USB drive.

- 450**            **Overflow during data collection: readings lost in USB transfer**  
Internal error: readings were collected too fast and were not buffered for output to the USB drive.
- 451**            **Overflow during USB output: readings lost in USB transfer**  
Internal error: USB write operation was unable to keep up with data collection.
- 452**            **Reading memory export aborted due to measurement reconfig**  
The export of reading memory was aborted because of measurement reconfiguration.
- 453**            **Not able to execute while logging data to USB**  
Operation can not be completed while data is being actively logged to USB.
- 454**            **Not able to execute while copying data to USB**  
Operation can not be completed while data is being exported to USB.
- 455**            **Not able to execute while importing a configuration from USB**  
Operation can not be completed while a measurement configuration is being imported from USB.
- 457**            **Logging request ignored: USB device is busy**  
Logging was not started because USB is busy, but the scan will continue to run normally, placing data in reading memory.
- 458**            **External USB drive is inaccessible**  
External USB drive can not be accessed; either the disk is full or else it may need to be reformatted. The instrument will behave as if no drive is present. The instrument was unable to find a valid partition to use for storing instrument data.

**Instrument Errors**

- 459**            **Logging to USB was stopped**  
Data logging was stopped prior to completion due to an abort or some other error condition.
- 460**            **Logging to USB was stopped after 2^32 sweeps of data**  
Instrument is only able to capture 2^32 (~4.3 billion) sweeps worth of data on an external USB drive
- 461**            **Memory lost: non-volatile settings; USB drive**  
Data in non-volatile memory was lost or corrupted. USB logging enable, row limit and column separator will be set to defaults.
- 462**            **Configuration import aborted**  
Reconfiguration of the instrument was aborted.
- 463**            **Configuration import failed**  
This is a summary error that will be generated if ANY other errors were reported during configuration import.
- 464**            **Invalid import file**  
The instrument did not recognize the USB configuration import file.
- 465**            **Import file cardset does not match instrument**  
The current instrument configuration does not match the cardset expected by the USB import file.
- 466**            **Operation not allowed in a configuration import file**  
An illegal command was used inside the USB import file.
- 467**            **No readings to export**  
Reading memory is empty; nothing was exported to the USB drive.
- 468**            **Unable to fetch measurement config from internal processor**  
The instrument was unable to fetch measurement configuration data from the secondary processor due to a communications error.
- 469**            **Internal processor returned an invalid measurement config**  
Configuration data returned by secondary processor was bad. Measurement configuration could not be determined.



- 470 Measurement was reconfigured; Cannot save configuration data**  
Measurement configuration no longer agrees with the corresponding set of readings. Configuration data will not be saved to the USB drive.
- 471 USB operation aborted; Cannot save configuration data**  
An abort or device clear was received while fetching configuration data from secondary processor. Configuration data will not be saved to the USB drive.
- 472 One or more blcfg file names invalid; files inaccessible**  
Agilent BenchLink Data Logger BLCFG configuration files on the USB drive are limited to 40 character filenames (including the .blcfg extension), and all characters must be ANSI. Only legal filenames will be selectable for import.
- 473 Disk contains too many blcfg files; oldest files inaccessible**  
Instrument will only catalog the 50 most recently created Agilent BenchLink Data Logger BLCFG files. Older files will not be selectable for import.

**Instrument Errors**

- 501 I/O processor: isolator framing error**
- 502 I/O processor: isolator overrun error**
- 511 Communications: RS-232 framing error**
- 512 Communications: RS-232 overrun error**
- 513 Communications: RS-232 parity error**
- 514 (34970A only) RS-232 only: unable to execute using HP-IB**  
There are three commands which are allowed only with the RS-232 interface: `SYSTEM:LOCAL`, `SYSTEM:REMOTE`, and `SYSTEM:RWLOCK`.
- 514 (34972A only) Not allowed; Instrument locked by another I/O session**  
The requested operation is not allowed because another I/O session has locked the instrument.
- 521 Communications: input buffer overflow**
- 522 Communications: output buffer overflow**
- 532 Not able to achieve requested resolution**  
The instrument cannot achieve the requested measurement resolution. You may have specified an invalid resolution in the `CONFIGure` or `MEASure?` command.
- 540 Not able to null channel in overload**  
The instrument cannot store an overload reading ( $9.90000000E+37$ ) as the offset for `Mx+B` scaling using a null measurement.
- 550 Not able to execute command in local mode**  
The instrument has received a `READ?` or `MEASure?` command while in the local mode.

---

## Self-Test Errors

The following errors indicate failures that may occur during a self-test. Refer to the *34970A/34972A Service Guide* for more information.

601	Self-test: front panel not responding
602	Self-test: RAM read/write
603	Self-test: A/D sync stuck
604	Self-test: A/D slope convergence
605	Self-test/Cal: not able to calibrate rundown gain
606	Self-test/Cal: rundown gain out of range
607	Self-test: rundown too noisy
608	Self-test: serial configuration readback
609	Self-test: DC gain x1
610	Self-test: DC gain x10
611	Self-test: DC gain x100
612	Self-test: Ohms 500 nA source
613	Self-test: Ohms 5 uA source
614	Self-test: DC 300V zero
615	Self-test: Ohms 10 uA source
616	Self-test: DC current sense
617	Self-test: Ohms 100 uA source
618	Self-test: DC high voltage attenuator
619	Self-test: Ohms 1 mA source
620	Self-test: AC rms zero
621	Self-test: AC rms full scale
622	Self-test: frequency counter
623	Self-test: not able to calibrate precharge
624	Self-test: not able to sense line frequency
625	Self-test: I/O processor not responding
626	Self-test: I/O processor self-test

---

## Calibration Errors

The following errors indicate failures that may occur during a calibration. Refer to the *34970A/34972A Service Guide* for more information.

- 701 Cal: security disabled by jumper**  
The calibration security feature has been disabled with a jumper inside the instrument. When applicable, this error will occur at power-on to alert you that the instrument is unsecured.
- 702 Cal: secured**  
The instrument is secured against calibration.
- 703 Cal: invalid secure code**  
You have entered an invalid calibration security code. You must use the same security code to unsecure the instrument that was used to secure it, and vice versa. The security code may contain up to 12 alphanumeric characters. The first character *must* be a letter, but the remaining characters can be letters, numbers, or an underscore ( \_ ). You do not have to use all 12 characters but the first character must always be a letter. *The security code is set to “HP034970” or “AT034972” when the instrument is shipped from the factory.*
- 704 Cal: secure code too long**  
The security code may contain up to 12 alphanumeric characters. A security code was received which contained more than 12 characters.
- 705 Cal: aborted**  
A calibration in progress is aborted when you turn off the instrument or send a bus Device Clear.
- 706 Cal: value out of range**  
The specified calibration value (CALibration:VALue) is not valid for the present measurement function and range.
- 707 Cal: signal measurement out of range**  
The specified calibration value (CALibration:VALue) does not match the signal applied to the instrument.
- 708 Cal: signal frequency out of range**  
The input signal frequency for an ac calibration does not match the required input frequency for this calibration.
- 709 Cal: no cal for this function or range**  
You cannot perform calibrations for most ac current ranges, the 100 M $\Omega$  resistance range, and period.

***NOTE:** The following error messages indicate possible hardware failures within the instrument. If any of the following errors occur, contact your nearest Agilent Service Center for repair.*

710	Cal: full scale correction out of range
720	Cal: DCV offset out of range
721	Cal: DCI offset out of range
722	Cal: RES offset out of range
723	Cal: FRES offset out of range
724	Cal: extended resistance self cal failed
725	Cal: 300V DC correction out of range
730	Cal: precharge DAC convergence failed
731	Cal: A/D turnover correction out of range
732	Cal: AC flatness DAC convergence failed
733	Cal: AC low frequency convergence failed
734	Cal: AC low frequency correction out of range
735	Cal: AC rms converter noise correction out of range
736	Cal: AC rms 100th scale correction out of range
740	Cal data lost: secure state
741	Cal data lost: string data
742	Cal data lost: DCV corrections
743	Cal data lost: DCI corrections
744	Cal data lost: RES corrections
745	Cal data lost: FRES corrections
746	Cal data lost: AC corrections

**Calibration Errors**

- 747 (34970A only) Config data lost: HP-IB address**
- 747 (34972A only) Calibration failed**
- 748 (34970A only) Config data lost: RS-232**
- 748 (34972A only) Cal checksum failed internal data**
- 749 DMM relay count data lost**

---

## Plug-In Module Errors

**NOTE:** *The following error messages indicate possible hardware failures within the instrument. If any of the following errors occur, contact your nearest Agilent Service Center for repair.*

901	Module hardware: unexpected data received
902	Module hardware: missing stop bit
903	Module hardware: data overrun
904	Module hardware: protocol violation
905	Module hardware: early end of data
906	Module hardware: missing end of data
907	Module hardware: module srq signal stuck low
908	Module hardware: not responding
910	Module reported an unknown module type
911	Module reported command buffer overflow
912	Module reported command syntax error
913	Module reported nonvolatile memory fault
914	Module reported temperature sensor fault
915	Module reported firmware defect
916	Module reported incorrect firmware installed

**Plug-In Module Errors**



---

## Application Programs

---

# Application Programs

This chapter contains several example programs to help you develop programs for your specific measurement application. See the *Agilent 34970A/34972A Programmer's Reference Help* for details on the SCPI language for the instrument.

The examples in this chapter have been tested on a PC running on Windows 95. The examples are written for use over the GPIB interface and require a VISA (*Virtual Instrument Software Architecture*) library for use with your GPIB interface card in your PC. You will want to make sure that you have the **visa32.dll** file in your *c:\windows\system* directory for the examples to work properly.

These programs were written for the 34970A, but other than the connectivity, the principles and code should generally apply to the 34972A as well.

For programs specific to the 34972A, see the product page at

**[www.agilent.com/find/34972A](http://www.agilent.com/find/34972A)**

**Note:** *The GPIB (IEEE-488) address is set to "09" when the instrument is shipped from the factory. The examples in this chapter assume an GPIB address of 09.*

---

## Example Programs for Excel 7.0

This section contains two example programs written using Excel macros (*Visual Basic® for Applications*) to control the 34970A/34972A. Using Excel, you can send SCPI commands to configure the instrument and then record measurement data on the Excel spreadsheet.

To write an Excel macro you must first open a module in Excel. Go to the **Insert** menu, choose *Macro*, and then *Module*. Name this module “Send Commands” by clicking on the tab with the right mouse button. Create another module and name it “Port Configuration”. You will use the “Port Configuration” module to configure all of the overhead required to communicate with the instrument over the interface. You will use the “Send Commands” module to send the SCPI commands to the instrument using the “Port Configuration” module.

Two Excel examples are included in this section. To enter the first example (“takeReadings”), type the text as shown on page 244 into the “Send Commands” module. Then type the text for configuring the interface as shown on page 245 into the “Port Configuration” module.

After entering the information for both modules, go to a spreadsheet and run the example program. Note that you must run the macro from a spreadsheet. With the cursor in the spreadsheet, select *Macro* from the **Tools** menu. Then double-click on the “takeReadings” macro in the Macro dialog box.

To run the second example (“ScanChannels”), type the text as shown on page 247 into the “Send Commands” module and reuse the “Port Configuration” module from the first example (page 245).

Make any changes necessary to suit your application in the “Send Commands” module. You must enter the information in the modules exactly as shown or an error will be generated. If several system errors occur while attempting to run a macro, you may have to reboot your PC to get the GPIB port to work properly.

**Note:** To use these examples with Windows® 3.1, you will need to modify the declarations at the top of the “Port Configuration” module. Change **visa32.dll** to **visa.dll** in all declarations.

## Chapter 6 Application Programs

### Example Programs for Excel 7.0

#### Excel 7.0 Example: takeReadings Macro

```

' *****
' This Excel Macro (Visual Basic) configures the 34970A for scanning with the 34901A,
' 34902A, or 34908A multiplexer modules. When this subroutine is executed, it will
' take the specified number of readings on the selected channel. You can easily modify the
' number of readings, channel delay, and channel number. To make these changes, modify the
' code in the section titled 'SET UP'. Note that you must have one of the above
' modules installed in slot 100 for this program to run properly. You must also have an
' GPIB interface card installed in your PC with the VISA or VTL library.
' *****
,
Option Explicit
Sub takeReadings()
    Columns(1).ClearContents
    Columns(2).ClearContents
    Dim I As Integer
    Dim numberMeasurements As Integer
    Dim measurementDelay As Single
    Dim points As Integer
    ' Used for counter in For-Next loop
    ' Number of readings
    ' Delay between relay closure and measurement
    ' *****
    ' To change the GPIB address, modify the variable 'VISAaddr' below.
    VISAaddr = "9"
    OpenPort
    SendSCPI "*RST"
    ' Open communications on GPIB
    ' Issue a Factory Reset to the instrument
    ' *****
    ' SET UP: Modify this section to select the number of readings, channel delay,
    ' and channel number to be measured.
    numberMeasurements = 10
    measurementDelay = 0.1
    ' Number of readings
    ' Delay (in secs) between relay closure and measurement
    ' Configure the function, range, and channel
    SendSCPI "CONF:VOLT:DC (@103)"
    ' Configure channel 103 for DC voltage
    ' *****
    ' Select channel delay and number of readings
    SendSCPI "ROUT:CHAN:DELAY " & Str$(measurementDelay)
    SendSCPI "TRIG:COUNT " & Str$(numberMeasurements)
    ' Set up the spreadsheet headings
    Cells(2, 1) = "Chan Delay:"
    Cells(2, 2) = measurementDelay
    Cells(2, 3) = "sec"
    Cells(3, 1) = "Reading #"
    Cells(3, 2) = "Value"

    SendSCPI "INIT"
    Do
    ' Start the readings and wait for instrument to put
    ' one reading in memory
        SendSCPI "DATA:POINTS?"
        ' Get the number of readings stored
        points = Val(getScpi())
    Loop Until points >= 1
    ' Remove one reading at a time from memory
    For I = 1 To numberMeasurements
        SendSCPI "DATA:REMOVE? 1"
        ' Request 1 reading from memory
        Cells(I + 3, 1) = I
        ' The reading number
        Cells(I + 3, 2) = Val(getScpi())
        ' The reading value
        Do
            ' Wait for instrument to put another reading in memory
            SendSCPI "DATA:POINTS?"
            ' Get the number of readings stored
            points = Val(getScpi())
        Loop Until points >= 1 Or I >= numberMeasurements
    Next I
    ClosePort
    ' Close communications on GPIB
End Sub

```

**Excel 7.0 Example: Port Configuration Macro**

```

Option Explicit
' Declarations for VISA.DLL
' Basic I/O Operations
Private Declare Function viOpenDefaultRM Lib "VISA32.DLL" Alias "#141" (sesn As Long) As Long
Private Declare Function viOpen Lib "VISA32.DLL" Alias "#131" (ByVal sesn As Long, _
    ByVal desc As String, ByVal mode As Long, ByVal TimeOut As Long, vi As Long) As Long
Private Declare Function viClose Lib "VISA32.DLL" Alias "#132" (ByVal vi As Long) As Long
Private Declare Function viRead Lib "VISA32.DLL" Alias "#256" (ByVal vi As Long, _
    ByVal Buffer As String, ByVal Count As Long, retCount As Long) As Long
Private Declare Function viWrite Lib "VISA32.DLL" Alias "#257" (ByVal vi As Long, _
    ByVal Buffer As String, ByVal Count As Long, retCount As Long) As Long

' Error Codes
Global Const VI_SUCCESS = 0
' Global Variables
Global videfaultRM As Long ' Resource manager id for VISA GPIB
Global vi As Long ' Stores the session for VISA
Dim errorStatus As Long ' VTL error code
Global VISAaddr As String

' =====
' This routine requires the file 'VISA32.DLL' which typically resides in the
' c:\windows\system directory on your PC. This routine uses the VTL Library to send
' commands to the instrument. A description of these and additional VTL commands can be
' found in the Agilent VISA User's Guide.
' =====
Public Sub SendSCPI(SCPICmd As String)
' This routine sends a SCPI command string to the GPIB port. If the command is a
' query command (contains a question mark), you must read the response with 'getScpi'

    Dim commandstr As String ' Command passed to instrument
    Dim actual As Long ' Number of characters sent/returned

    'Write the command to the instrument terminated by a line feed
    commandstr = SCPICmd & Chr$(10)
    errorStatus = viWrite(vi, ByVal commandstr, Len(commandstr), actual)
End Sub

Function getScpi() As String
    Dim readbuf As String * 2048 ' Buffer used for returned string
    Dim replyString As String ' Store the string returned
    Dim nulpos As Integer ' Location of any nul's in readbuf
    Dim actual As Long ' Number of characters sent/returned

    ' Read the response string
    errorStatus = viRead(vi, ByVal readbuf, 2048, actual)
    replyString = readbuf
    ' Strip out any nul's from the response string
    nulpos = InStr(replyString, Chr$(0))
    If nulpos Then
        replyString = Left(replyString, nulpos - 1)
    End If
    getScpi = replyString
End Function

```



*Continued on next page*

## Chapter 6 Application Programs

### Example Programs for Excel 7.0

```
Sub OpenPort ()
/*****
' Be sure that the GPIB address has been set in the 'VISAAddr' variable
' before calling this routine.
*****/
' Open the VISA session
errorStatus = viOpenDefaultRM(videfaultRM)
' Open communications to the instrument
errorStatus = viOpen(videfaultRM, "GPIB0:" & VISAAddr & "::INSTR", 0, 2500, vi)
' If an error occurs, give a message
If errorStatus < VI_SUCCESS Then
  Range("A2").Select
  Cells(1, 1) = "Unable to Open Port"
End If
End Sub

Sub ClosePort ()
  errorStatus = viClose(vi)
  ' Close the session
  errorStatus = viClose(videfaultRM)
End Sub

/*****
' This subroutine is used to create delays. The input is in seconds and
' fractional seconds are allowed.
*****/
Sub delay(delay_time As Single)
  Dim Finish As Single
  Finish = Timer + delay_time
  Do
  Loop Until Finish <= Timer
End Sub
```

**Excel 7.0 Example: ScanChannels Macro**

```

' *****
' This Excel Macro (Visual Basic) configures the 34970A for scanning with the 34901A,
' 34902A, or 34908A multiplexer modules. When this subroutine is executed, it will
' scan 5 channels and display the readings on a spreadsheet. You can easily modify the
' channels in the scan list, number of scans, channel delay, and scan delay. To make these
' changes, modify the code in the section titled 'SET UP'. Note that you must have one of
' the above modules installed in slot 100 for this program to run properly. You must also
' have an GPIB interface card installed in your PC with the VISA or VTL library.
' *****

Option Explicit
Sub ScanChannels()
    Dim columnIndex As Integer          ' The column number of the data
                                        ' "1" indicates the first data column
    Dim numberScans As Integer          ' Total number of scans
    Dim numberChannels As Integer       ' Total number of scanned channels
    Dim ScanInterval As Single          ' Time interval in seconds between scans
    Dim points As Integer               ' Reading count in instrument memory
    Dim replyString As String           ' Store the string returned from instrument
    Dim scanList As String              ' List of channels included in scan
    Dim channelDelay As Single          ' Delay between relay closure and measurement
    Dim Channel As Integer
    Range("a1:ba40").ClearContents    ' Clear the spreadsheet
'
' *****
' To change the GPIB address, modify the variable 'VISAaddr' below.
VISAaddr = "9"
OpenPort                               ' Open communications on GPIB
SendSCPI "*RST"                         ' Issue a Factory Reset to the instrument
' *****
' SET UP: Modify this section to select the scan interval, the scan count,
' and channel delay.
'
' These are variables that are used to set the scan parameters
ScanInterval = 10                       ' Delay (in secs) between scans
numberScans = 3                         ' Number of scan sweeps to measure
channelDelay = 0.1                      ' Delay (in secs) between relay closure and measurement
' To delete channels from the scan list, modify the scan list string variable
' 'scanList' below. To add channels to the scan list, modify 'scanList' and then
' configure the channel using the CONFigure command.
'
' 'scanList' is the list of channels in the scan list; note that this does not have
' to include all configured channels in the instrument.
scanList = "@101,102,110:112)"
SendSCPI "CONF:TEMP TC,T,@(101)"        ' Configure channel 101 for temperature
SendSCPI "CONF:TEMP TC,K,@(102)"        ' Configure channel 102 for temperature
SendSCPI "CONF:TEMP THER,5000,@(103)"   ' Configure channel 103 for temperature
SendSCPI "CONF:VOLT:DC (@110,111,112)"   ' Configure three channels for DC volts
' *****
SendSCPI "ROUTE:SCAN " & scanList      ' Select the list of channels to scan
SendSCPI "ROUTE:SCAN:SIZE?"            ' Query the number of channels in scan list and
numberChannels = Val(GetSCPI())         ' set variable equal to number of channels
SendSCPI "FORMAT:READING:CHAN ON"      ' Return channel number with each reading
SendSCPI "FORMAT:READING:TIME ON"      ' Return time stamp with each reading
' Set the delay (in seconds) between relay closure and measurement
SendSCPI "ROUT:CHAN:DELAY " & Str$(channelDelay) & "," & scanList

```

*Continued on next page*

## Chapter 6 Application Programs

### Example Programs for Excel 7.0

```
' Set up the scan trigger parameters after configuring the channels in the scan list
' using the CONFIGure command. The following commands configure the scan interval.
SendSCPI "TRIG:COUNT " & Str$(numberScans)
SendSCPI "TRIG:SOUR TIMER"
SendSCPI "TRIG:TIMER " & Str$(ScanInterval)
Cells(2, 1) = "Start Time"          ' Put headings on spreadsheet
Cells(4, 1) = "Channel"            ' Put headings on spreadsheet

' Start the scan and retrieve the scan start time
SendSCPI "INIT;:SYSTEM:TIME:SCAN?"
replyString = GetSCPI()             ' Put time into string variable
' Convert the time to Excel format and put into cells B2 and C2
Cells(2, 2) = ConvertTime(replyString)
Cells(2, 3) = Cells(2, 2)
Cells(2, 3).NumberFormat = "d-mmm-yy" ' Format for date
Cells(2, 2).NumberFormat = "hh:mm:ss" ' Format for time
Range("a1:ba1").ClearContents     ' Clear out row 1

' Step through the number of scan sweeps
For columnIndex = 1 To numberScans ' Start of scan data
    Do ' Wait for instrument to put a reading in memory
        SendSCPI "DATA:POINTS?"    ' Get the number of readings stored
        points = Val(GetSCPI())
    Loop Until points >= 1
    ' Remove one reading at a time from memory
    For Channel = 1 To numberChannels
        SendSCPI "DATA:REMOVE? 1"   ' Request one reading from memory
        Application.ScreenUpdating = False
        ' Get readings from buffer and store in cell A1
        Cells(1, 1) = GetSCPI()
        ' Parse the string in cell A1 and put into row '1'
        Range("a1").TextToColumns Destination:=Range("a1"), comma:=True
        ' Call routine to organize the data in row 1 into a table
        makeDataTable Channel, columnIndex
        Range("a1:ba1").ClearContents ' Clear out row 1
        Application.ScreenUpdating = True
        Do ' Wait for instrument to put another reading in memory
            SendSCPI "DATA:POINTS?" ' Get the number of readings stored
            points = Val(GetSCPI())
        Loop Until points >= 1 Or Channel >= numberChannels
    Next Channel
Next columnIndex
ClosePort ' Close communications on GPIB
End Sub
```

*Continued on next page*



```

Sub makeDataTable(Channel As Integer, columnIndex As Integer)
' This routine will take the parsed data in row '1' for a channel and put it into a
' table. 'Channel' determines the row of the table and 'columnIndex' determines the
' column (scan sweep count).

' The number of comma-delimited fields returned per channel is determined by the
' FORMat:READing commands. The number of fields per channel is required to locate
' the data in row 1. In this example, there are three cells (fields) per channel.
' Set up the heading while scanning the first channel.
If Channel = 1 Then
' Label the top of the data column and time stamp column
Cells(4, columnIndex * 2) = "Scan " & Str(columnIndex)
Cells(4, columnIndex * 2).Font.Bold = True
Cells(3, columnIndex * 2 + 1) = "time stamp"
Cells(4, columnIndex * 2 + 1) = "min:sec"
End If
' Get channel number, put in column 'A' for first scan only
If columnIndex = 1 Then
Cells(Channel + 4, 1) = Cells(1, 3)
End If
' Get the reading data and put into the column
Cells(Channel + 4, columnIndex * 2) = Cells(1, 1)
' Get the time stamp and put into the column to the right of data; to convert relative
' time to Excel time, divide by 86400.
Cells(Channel + 4, columnIndex * 2 + 1) = Cells(1, 2) / 86400
Cells(Channel + 4, columnIndex * 2 + 1).NumberFormat = "mm:ss.0"
End Sub

Function ConvertTime(TimeString As String) As Date
' This routine will take the string returned from the SYSTEM:TIME:SCAN? command and
' return a number compatible with the Excel format. When loaded into a cell, it can
' be formatted using the Excel 'Format' menu.
Dim timeNumber As Date ' Decimal or time portion of the number
Dim dateNumber As Date ' Integer or date portion of the number
Cells(1, 1).ClearContents
Cells(1, 1) = TimeString
Range("a1").TextToColumns Destination:=Range("a1"), comma:=True
dateNumber = DateSerial(Cells(1, 1), Cells(1, 2), Cells(1, 3))
timeNumber = TimeSerial(Cells(1, 4), Cells(1, 5), Cells(1, 6))
ConvertTime = dateNumber + timeNumber
End Function

Sub GetErrors()
' Call this routine to check for instrument errors. The GPIB address variable
' 'VISAaddr' must be set.
Dim DataString As String
OpenPort
SendSCPI "SYSTEM:ERROR?" ' Read one error from the error queue
Delay (0.1)
DataString = GetSCPI()
MsgBox DataString
ClosePort
End Sub

```

## Example Programs for C and C++

The following C programming examples show you how to send and receive formatted I/O. For more information on non-formatted I/O, refer to the Agilent VISA *User's Guide*. The examples in this section show you how to use the SCPI commands for the instrument with the VISA functionality and does not include error trapping. Error trapping, however, is good programming practice and is recommended for your application. For more information on error trapping, refer to the Agilent VISA *User's Guide*.

The example programs are written in Microsoft® Visual C++ Version 1.52 using project type “QuickWin application”, and using the large memory model. Be sure to have access in the project to **visa.lib** or **visa32.lib** usually found in the *c:\vxiipnp* or *c:\visa* directory.

**C/C++ Example: dac\_out.c**

```

/* dac_out.c
/*****
* Required: 34907A Multifunction Module in slot 200; VISA library      *
* This program uses the VISA library to communicate with the 34970A.  *
* The program queries slot 200 and displays the response. It then resets *
* the instrument and sends the value 'voltage' to the DAC on channel 205. *
*****/

#include <visa.h>
#include <stdio.h>
#include <string.h>
#define ADDR "9" /* Set GPIB address for instrument */

void main ()
{
    ViSession defaultRM; /* Resource manager id */
    ViSession dac; /* Identifies instrument */
    char reply_string [256]; /* String returned from instrument */
    char Visa_address[40]; /* VISA address sent to module */
    double voltage; /* Value of voltage sent to DAC */

    /* Build the address required to open communication with GPIB card.
       The address format looks like this "GPIB0::9::INSTR". */
    strcpy(Visa_address, "GPIB0::");
    strcat(Visa_address, ADDR);
    strcat(Visa_address, "::INSTR");

    /* Open communication (session) with the 34970A */

    viOpenDefaultRM (&defaultRM);
    viOpen (defaultRM, Visa_address, VI_NULL, VI_NULL, &dac);

    /* Query the module id in slot 200; Read response and print. */
    viPrintf (dac, "SYST:CTYPE? 200\n");
    viScanf (dac, "%s", &reply_string);
    printf("Instrument identification string:\n %s\n\n", reply_string);

    viPrintf (dac, "*RST\n"); /* Set power-on condition */
    voltage = 5; /* Set variable to voltage setting */
    viPrintf (dac, "SOURCE:VOLTAGE %f, (@205)\n", voltage); /* Set output voltage */
    /* Close communication session */
    viClose (dac);
    viClose (defaultRM);
}

```

## Chapter 6 Application Programs

### Example Programs for C and C++

#### C/C++ Example: stat\_reg.c

```
/* stat_reg.c
/*****
* Required: VISA library.
* This program demonstrates the use of the 34970A Status Registers
* for an alarm and Operation Complete (OPC) and for enabling and receiving
* an SRQ interrupt. This program also shows how to configure a scan for
* 10 readings on one channel.
*****/

#include <visa.h>
#include <stdio.h>
#include <string.h>

ViSession defaultRM;          /* Resource manager id */
ViSession DataAcqu;          /* Variable to identify an instrument */
char reply_string [256]= {0}; /* string returned from instrument */
double volt [10];
int index, count;
int srqFlag = {0};

/* Function prototypes for SRQ handler */
ViStatus _VI_FUNCH SRQ_handler(ViSession DataAcqu, ViEventType eventType,
    ViEvent context,ViAddr userHdlr);

void main ()
{
    /* Open communication with DataAcqu using GPIB address "9" */
    viOpenDefaultRM (&defaultRM);
    viOpen (defaultRM,"GPIB0::9::INSTR",VI_NULL,VI_NULL, &DataAcqu);

    /* Reset instrument to power-on and clear the Status Byte */
    viPrintf (DataAcqu, "**RST;*CLS\n");

    /* Configure the Status Registers to generate an interrupt whenever an alarm
       is detected on Alarm 1 or when the operation is complete */
    viPrintf (DataAcqu, "STATUS:ALARM:ENABLE 1\n"); /* Enable Alarm 1 */
    viPrintf (DataAcqu, "**ESE 1\n"); /* Enable the Operation Complete bit */
    /* Enable Status Byte Register bit 1 (2) and 5 (32) for SRQ */
    viPrintf (DataAcqu, "**SRE 34\n");
    /* Enable the interrupt handler for SRQ from the instrument */
    viInstallHandler(DataAcqu, VI_EVENT_SERVICE_REQ, SRQ_handler, (ViAddr)10);
    viEnableEvent(DataAcqu,VI_EVENT_SERVICE_REQ, VI_HNDLR, VI_NULL);
    /* Configure the instrument to take 10 DC voltage readings on channel 103.
       Set the alarm and set SRQ if the voltage is greater than 5 volts.*/
    viPrintf (DataAcqu, "CONF:VOLT:DC 10, (@103)\n");
    viPrintf (DataAcqu, "TRIG:SOURCE TIMER\n");
    viPrintf (DataAcqu, "TRIG:TIMER 1\n");
    viPrintf (DataAcqu, "TRIG:COUNT 10\n");
    viPrintf (DataAcqu, "CALC:LIMIT:UPPER 5, (@103)\n");
    viPrintf (DataAcqu, "CALC:LIMIT:UPPER:STATE ON, (@103)\n");
    viPrintf (DataAcqu, "OUTPUT:ALARM1:SOURCE (@103)\n");
    viPrintf (DataAcqu, "INIT;*OPC\n");
    /* Wait for the instrument to complete its operations so waste time
       and stay in the program in case there is an SRQ */
}
```

*Continued on next page*

```

do{ /* Stay in loop until the srqFlag goes negative */
    index = 1;
    for (count = 0; count <45; count++)
        {
            index = 0;
            printf(".");
        }
    printf(" srq flag = %d\n",srqFlag);
}
while (srqFlag>=0); /* A negative srqFlag indicates scan is done */
/* The instrument is done, so close the SRQ handler */
viDisableEvent (DataAcqu,VI_EVENT_SERVICE_REQ,VI_HNDLR);
viUninstallHandler (DataAcqu,VI_EVENT_SERVICE_REQ,SRQ_handler, (ViAddr)10);

viPrintf (DataAcqu,"FETCH?\n"); /* Get all the readings */
viScanf(DataAcqu,"%10lf",&volt);/* Put readings into an array */
for (index = 0;index<10;index++){ /* Print the readings */
    printf("reading %d = %lf\n",index+1,volt[index]);
}

viClose (DataAcqu);          /* Close the communication port */
viClose (defaultRM);
}

/* This function will be called when the instrument interrupts the controller with
an SRQ for alarm and/or Operation Complete */
ViStatus _VI_FUNCH SRQ_handler(ViSession DataAcqu, ViEventType eventType,
ViEvent context,ViAddr userHdlr)
{
    ViUInt16 statusByte;
    viReadSTB(DataAcqu,&statusByte); /* Read status byte register and clear SRQ */
    /* Bit 6 (64) indicates this SRQ is for our instrument, bit 1 (2) indicates
    an alarm, and bit 5 (32) indicates the standard event register;
    so alarm 64+2=66; OPC 64+32=96; both 64+32+2=98 */
    if ((statusByte==66)|(statusByte==98)){
        srqFlag = 1; /* Set flag to indicate this is an alarm */
        viPrintf (DataAcqu,"STATUS:ALARM:EVENT?\n");/* Check and clear alarm */
        viScanf(DataAcqu,"%s",&reply_string);
        printf("alarm event; bit = %s\n",reply_string);
    }
    if ((statusByte==96)|(statusByte==98)){
        srqFlag = -1; /* Set flag to indicate end of operation */
        viPrintf (DataAcqu,"*ESR?\n"); /* Check and clear ESR bit */
        viScanf(DataAcqu,"%s",&reply_string);
        printf("Standard Event Register; bit %s\n",reply_string);
    }
    return VI_SUCCESS;
}

```



 Tutorial

---

# Tutorial

This chapter describes methods that you can use to reduce errors that can affect your measurements. You will also find information to help you better understand how the 34970A/34972A makes measurements and what you can do to get the best results. This chapter is divided into the following sections:

- System Cabling and Connections, *on page 257*
- Measurement Fundamentals, *on page 265*
- Low-Level Signal Multiplexing and Switching, *on page 300*
- Actuators and General-Purpose Switching, *on page 306*
- Matrix Switching, *on page 310*
- RF Signal Multiplexing, *on page 312*
- Multifunction Module, *on page 314*
- Relay Life and Preventive Maintenance, *on page 321*



---

## System Cabling and Connections

This section describes methods to reduce measurement errors that can be introduced by your system cabling. Many system cabling errors can be reduced or eliminated by selecting the proper cable and grounding scheme for your system.

### Cable Specifications

A wide variety of general-purpose and custom cables are available. The following factors influence the type of cable that you choose.

- *Signal Requirements* – such as voltage, frequency, accuracy, and measurement speed.
- *Interconnection Requirements* – such as wire sizes, cable lengths, and cable routing.
- *Maintenance Requirements* – such as intermediate connectors, cable terminations, strain relief, cable lengths, and cable routing.

Cables are specified in a variety of ways. Be sure to check the following specifications for the cable type you intend to use (continued on the following page).

- *Nominal Impedance (insulation resistance)* – Varies with the frequency of the input signal. Check for HI-to-LO, channel-to-channel, and HI- or LO-to-shield. High frequency RF applications have exact requirements for cable impedance.
- *Dielectric Withstand Voltage* – Must be high enough for your application.

---

#### WARNING

*To prevent electrical shock or equipment damage, insulate all channels to the highest potential in the system. It is recommended that you use wire with 600 V rated insulation.*

---

Chapter 7 Tutorial  
**System Cabling and Connections**

- *Cable Resistance* – Varies with wire gauge size and cable length. Use the largest gauge wire possible and try to keep the cable lengths as short as possible to minimize the cable resistance. The following table lists typical cable resistance for copper wire of several gauge sizes (the temperature coefficient for copper wire is 0.35% per °C).

AWG	$\Omega$ / ft (2 conductors) at 25 °C
14	5 m $\Omega$
16	10 m $\Omega$
18	15 m $\Omega$
20 *	20 m $\Omega$
22	30 m $\Omega$
24	50 m $\Omega$

\* *Recommended wire size for the screw terminals on 34970A/34972A plug-in modules.*

- *Cable Capacitance* – Varies with the insulation type, cable length, and cable shielding. Cables should be kept as short as possible to minimize cable capacitance. In some cases, low-capacitance cable can be used.

The table below lists *typical* cable specifications.

Cable Type	Nominal Impedance	Capacitance	Attenuation
Twisted Pair	100 $\Omega$ at 1 MHz	10 to 20 pF/ft	Up to 1 dB/100 ft at 1 MHz
Shielded Twisted Pair	100 $\Omega$ at 1 MHz	10 to 20 pF/ft	Up to 1 dB/100 ft at 1 MHz
Coaxial	50 $\Omega$ or 75 $\Omega$ at 100 MHz	15 to 25 pF/ft	Up to 6 dB/100 ft at 100 MHz
Twisted Pair Ribbon	100 $\Omega$ at 1 MHz	15 to 20 pF/ft	Up to 1 dB/100 ft at 1 MHz

## Grounding Techniques

One purpose of grounding is to avoid ground loops and minimize noise. Most systems should have at least three separate ground returns.

1. One ground for signals. You may also want to provide separate signal grounds between high-level signals, low-level signals, and digital signals.
2. A second ground is used for noisy hardware such as relays, motors, and high-power equipment.
3. A third ground is used for chassis, racks, and cabinets. The AC power ground should generally be connected to this third ground.

In general, for frequencies below 1 MHz or for low-level signals, use single-point grounding (*see below*). Parallel grounding is superior but is also more expensive and more difficult to wire. If single-point grounding is adequate, the most critical points (those with the lowest levels and/or the most precise measurement requirements) should be positioned near the primary ground point. For frequencies above 10 MHz, use the separate grounding system. For signals between 1 MHz and 10 MHz, you can use a single-point system if the longest ground return path is kept to less than  $1/20$  of a wavelength. In all cases, return-path resistance and inductance should be minimized.

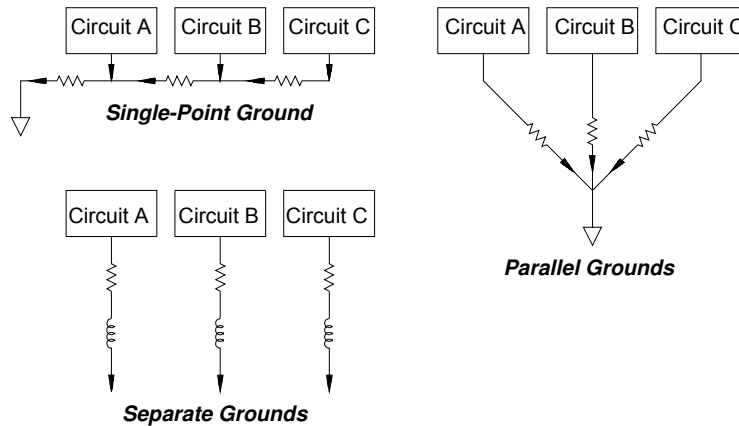

## Shielding Techniques

Shielding against noise must address both capacitive (electrical) and inductive (magnetic) coupling. The addition of a grounded shield around the conductor is highly effective against capacitive coupling. In switching networks, this shielding often takes the form of coaxial cables and connectors. For frequencies above 100 MHz, double-shielded coaxial cable is recommended to maximize shielding effectiveness.

Reducing loop area is the most effective method to shield against magnetic coupling. Below a few hundred kilohertz, twisted pairs may be used against magnetic coupling. Use shielded twisted pair for immunity from magnetic and capacitive pickup. For maximum protection below 1 MHz, make sure that the shield *is not one* of the signal conductors.

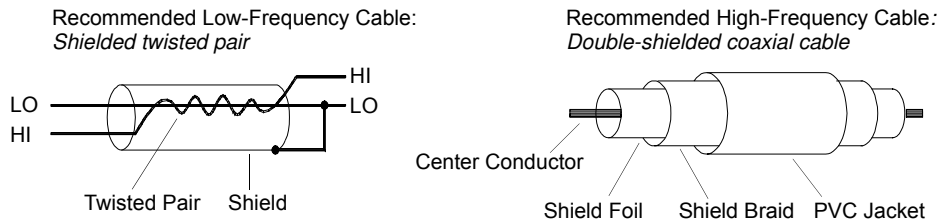

## Separation of High-Level and Low-Level Signals

Signals whose levels exceed a 20-to-1 ratio should be physically separated as much as possible. The entire signal path should be examined including cabling and adjacent connections. All unused lines should be grounded (or tied to LO) and placed between sensitive signal paths. When making your wiring connections to the screw terminals on the module, be sure to wire *like* functions on adjacent channels.

## Sources of System Cabling Errors

**Radio Frequency Interference** Most voltage-measuring instruments can generate false readings in the presence of large, high-frequency signals. Possible sources of high-frequency signals include nearby radio and television transmitters, computer monitors, and cellular telephones. High-frequency energy can also be coupled to the internal DMM on the system cabling. To reduce the interference, try to minimize the exposure of the system cabling to high-frequency RF sources.

If your application is extremely sensitive to RFI radiated from the instrument, use a common mode choke in the system cabling as shown below to attenuate instrument emissions.

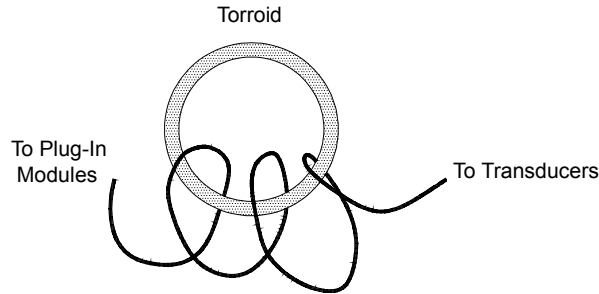

**Thermal EMF Errors** Thermoelectric voltages are the most common source of error in low-level DC voltage measurements. Thermoelectric voltages are generated when you make circuit connections using dissimilar metals at different temperatures. Each metal-to-metal junction forms a *thermocouple*, which generates a voltage proportional to the junction temperature difference. You should take the necessary precautions to minimize thermocouple voltages and temperature variations in low-level voltage measurements. The best connections are formed using copper-to-copper crimped connections. The table below shows common thermoelectric voltages for connections between dissimilar metals.

Copper-to-	Approx. $\mu\text{V}/^\circ\text{C}$
Copper	<0.3
Gold	0.5
Silver	0.5
Brass	3
Beryllium Copper	5
Aluminum	5
Kovar or Alloy 42	40
Silicon	500
Copper-Oxide	1000
Cadmium-Tin Solder	0.2
Tin-Lead Solder	5

**Noise Caused by Magnetic Fields** If you are making measurements near magnetic fields, you should take precautions to avoid inducing voltages in the measurement connections. Voltage can be induced by either movement of the input connection wiring in a fixed magnetic field or by a varying magnetic field. An unshielded, poorly dressed input wire moving in the earth's magnetic field can generate several millivolts. The varying magnetic field around the AC power line can also induce voltages up to several hundred millivolts. You should be especially careful when working near conductors carrying large currents.

Where possible, you should route cabling away from magnetic fields. Magnetic fields are commonly present around electric motors, generators, televisions, and computer monitors. Also make sure that your input wiring has proper strain relief and is tied down securely when operating near magnetic fields. Use twisted-pair connections to the instrument to reduce the noise pickup loop area, or dress the wires as close together as possible.

**Noise Caused by Ground Loops** When measuring voltages in circuits where the internal DMM and the device-under-test are both referenced to a common earth ground, a *ground loop* is formed. As shown below, any voltage difference between the two ground reference points ( $V_{\text{ground}}$ ) causes a current to flow through the LO measurement lead. This causes an error voltage ( $V_L$ ) which is added to the measured voltage.

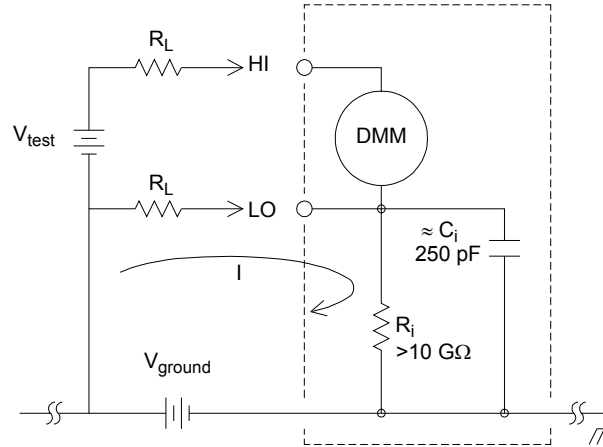

Where:

$R_L$  = Lead resistance

$R_i$  = DMM isolation resistance

$C_i$  = DMM isolation capacitance

$V_{\text{ground}}$  = Ground noise voltage

$$I = \text{Current flow caused by } V_{\text{ground}} = \frac{V_{\text{ground}}}{R_L + Z}$$

$$Z \approx Z_{C_i} = \frac{1}{2\pi fC} \approx 10 \text{ M}\Omega \text{ at 50 or 60 Hz}$$

$$V_L = I \times R_L$$

To minimize ground loop errors:

- If  $V_{\text{ground}}$  is a DC voltage, keep  $R_L$  small compared to  $R_i$ .
- If  $V_{\text{ground}}$  is an AC voltage, keep  $R_L$  small compared to  $Z$ , and set the DMM's integration time to 1 PLC or greater (see page 120 for a discussion of integration time).

***Low-Level AC Measurement Errors*** When measuring AC voltages less than 100 mV, be aware that these measurements are especially susceptible to errors introduced by extraneous noise sources. An exposed test lead will act as an antenna and the internal DMM will measure the signals received. The entire measurement path, including the power line, act as a loop antenna. Circulating currents in the loop will create error voltages across any impedances in series with the instrument's input. For this reason, you should apply low-level AC voltages to the instrument through shielded cables. You should also connect the shield to the input LO terminal.

Be sure to minimize the area of any ground loops that cannot be avoided. A high-impedance source is more susceptible to noise pickup than a low-impedance source. You can reduce the high-frequency impedance of a source by placing a capacitor in parallel with the instrument's input terminals. You may have to experiment to determine the correct capacitance value for your application.

Most extraneous noise is not correlated with the input signal. You can determine the error as shown below.

$$\text{Voltage Measured} = \sqrt{V_{in}^2 + \text{Noise}^2}$$

Correlated noise, while rare, is especially detrimental. Correlated noise will always add directly to the input signal. Measuring a low-level signal with the same frequency as the local power line is a common situation that is prone to this error.

You should use caution when switching high-level and low-level signals on the same module. It is possible that high-level charged voltages may be discharged onto a low-level channel. It is recommended that you either use two different modules or separate the high-level signals from the low-level signals with an unused channel connected to ground.



---

## Measurement Fundamentals

This section explains how the 34970A/34972A makes measurements and discusses the most common sources of error related to these measurements.

### The Internal DMM

The internal DMM provides a universal input front-end for measuring a variety of transducer types without the need for additional external signal conditioning. The internal DMM includes signal conditioning, amplification (or attenuation), and a high resolution (up to 22 bits) analog-to-digital converter. A simplified diagram of the internal DMM is shown below. *For complete details on the operation of the internal DMM, refer to “Measurement Input” on page 74.*

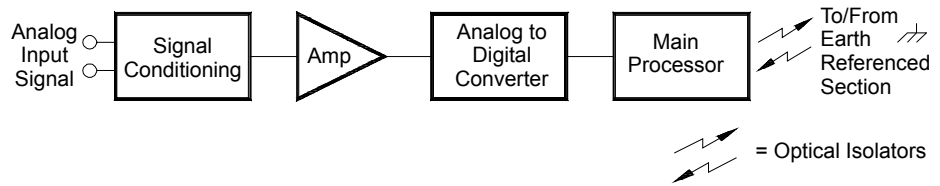

The internal DMM can directly make the following types of measurements. Each of these measurements is described in the following sections of this chapter.

- Temperature (thermocouple, RTD, and thermistor)
- Voltage (dc and AC up to 300V)
- Resistance (2-wire and 4-wire up to 100 MΩ)
- Current (dc and AC up to 1A)
- Frequency and Period (up to 300 kHz)

**Rejecting Power-Line Noise Voltages** A desirable characteristic of an integrating analog-to-digital (A/D) converter is its ability to reject spurious signals. Integrating techniques reject power-line related noise present with DC signals on the input. This is called *normal mode rejection* or NMR. Normal mode noise rejection is achieved when the internal DMM measures the average of the input by “integrating” it over a fixed period. If you set the integration time to a whole number of power line cycles (PLCs) of the spurious input, these errors (and their harmonics) will average out to approximately zero.

When you apply power to the internal DMM, it measures the power-line frequency (50 Hz or 60 Hz), and uses this measurement to determine the integration time. The table below shows the noise rejection achieved with various configurations. For better resolution and increased noise rejection, select a longer integration time.

PLCs	Digits	Bits	Integration Time 60 Hz (50 Hz)	NMR
0.02	4½	15	400 µs (400 µs)	0 dB
0.2	5½	18	3 ms (3 ms)	0 dB
1	5½	20	16.7 ms (20 ms)	60 dB
2	6½	21	33.3 ms (40 ms)	90 dB
10	6½	24	167 ms (200 ms)	95 dB
20	6½	25	333 ms (400 ms)	100 dB
100	6½	26	1.67 s (2 s)	105 dB
200	6½	26	3.33 s (4 s)	110 dB

The following graph shows the attenuation of AC signals measured in the DC voltage function for various A/D integration time settings. Note that signal frequencies at multiples of  $1/T$  exhibit high attenuation.

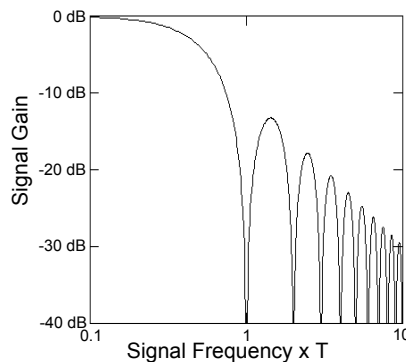

## Temperature Measurements

A temperature transducer measurement is typically either a resistance or voltage measurement converted to an equivalent temperature by software conversion routines inside the instrument. The mathematical conversion is based on specific properties of the various transducers. The mathematical conversion accuracy (not including the transducer accuracy) for each transducer type is shown below.

Transducer	Conversion Accuracy
Thermocouple	0.05°C
RTD	0.02°C
Thermistor	0.05°C

Errors associated with temperature measurements include all of those listed for DC voltage and resistance measurements elsewhere in this chapter. The largest source of error in temperature measurements is generally the transducer itself.

Your measurement requirements will help you to determine which temperature transducer type to use. Each transducer type has a particular temperature range, accuracy, and cost. The table below summarizes some typical specifications for each transducer type. Use this information to help select the transducer for your application. The transducer manufacturers can provide you with exact specifications for a particular transducer.

Parameter	Thermocouple	RTD	Thermistor
Temperature Range	-210°C to 1820°C	-200°C to 850°C	-80°C to 150°C
Measurement Type	Voltage	2- or 4-Wire Ohms	2- or 4-Wire Ohms
Transducer Sensitivity	6 $\mu\text{V}/^\circ\text{C}$ to 60 $\mu\text{V}/^\circ\text{C}$	$\approx R_0 \times 0.004^\circ\text{C}$	$\approx 400\Omega/^\circ\text{C}$
Probe Accuracy	0.5°C to 5°C	0.01°C to 0.1°C	0.1°C to 1°C
Cost (U.S. Dollars)	\$1 / foot	\$20 to \$100 each	\$10 to \$100 each
Durability	Rugged	Fragile	Fragile

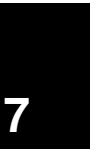

***RTD Measurements*** An RTD is constructed of a metal (typically platinum) that changes resistance with a change in temperature in a precisely known way. The internal DMM measures the resistance of the RTD and then calculates the equivalent temperature.

An RTD has the highest stability of the temperature transducers. The output from an RTD is also very linear. This makes an RTD a good choice for high-accuracy, long-term measurements. The 34970A/34972A supports RTDs with  $\alpha = 0.00385$  (DIN / IEC 751) using ITS-90 software conversions and  $\alpha = 0.00391$  using IPTS-68 software conversions. “PT100” is a special label that is sometimes used to refer to an RTD with  $\alpha = 0.00385$  and  $R_0 = 100\Omega$ .

The resistance of an RTD is nominal at 0 °C and is referred to as  $R_0$ . The 34970A/34972A can measure RTDs with  $R_0$  values from 49 $\Omega$  to 2.1 k $\Omega$ .

You can measure RTDs using a 2-wire or 4-wire measurement method. The 4-wire method provides the most accurate way to measure small resistances. Connection lead resistance is automatically removed using the 4-wire method.

***Thermistor Measurements*** A thermistor is constructed of materials that non-linearly changes resistance with changes in temperature. The internal DMM measures the resistance of the thermistor and then calculates the equivalent temperature.

Thermistors have a higher sensitivity than thermocouples or RTDs. This makes a thermistor a good choice when measuring very small changes in temperature. Thermistors are, however, very non-linear, especially at high temperatures and function best below 100 °C.

Because of their high resistance, thermistors can be measured using a 2-wire measurement method. The internal DMM supports 2.2 k $\Omega$  (44004), 5 k $\Omega$  (44007), and 10 k $\Omega$  (44006) thermistors. The thermistor conversion routines used by the 34970A/34972A are compatible with the *International Temperature Scale of 1990* (ITS-90).

**Thermocouple Measurements** A thermocouple converts temperature to voltage. When two wires composed of dissimilar metals are joined, a voltage is generated. The voltage is a function of the *junction temperature* and the types of metals in the thermocouple wire. Since the temperature characteristics of many dissimilar metals are well known, a conversion from the voltage generated to the temperature of the junction can be made. For example, a voltage measurement of a T-type thermocouple (made of copper and constantan wire) might look like this:

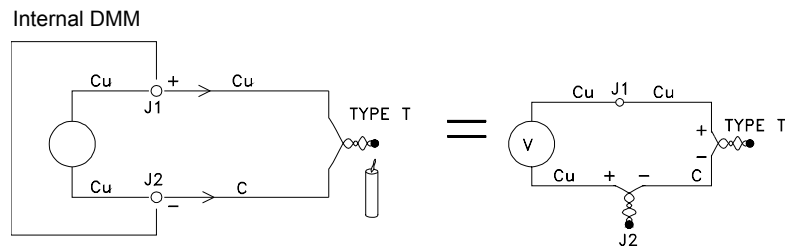

Notice, however, that the connections made between the thermocouple wire and the internal DMM make a second, unwanted thermocouple where the constantan (C) lead connects to the internal DMM's copper (Cu) input terminal. The voltage generated by this second thermocouple affects the voltage measurement of the T-type thermocouple.

If the temperature of the thermocouple created at J2 (the LO input terminal) is known, the temperature of the T-type thermocouple can be calculated. One way to do this is to connect two T-type thermocouples together to create only copper-to-copper connections at the internal DMM's input terminals, and to hold the second thermocouple at a known temperature.

## Chapter 7 Tutorial

### Measurement Fundamentals

An *ice bath* is used to create a known reference temperature (0 °C). Once the reference temperature and thermocouple type are known, the temperature of the measurement thermocouple can be calculated.

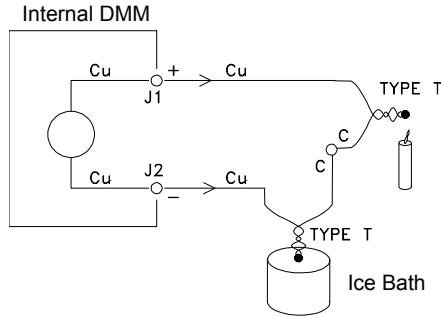

The T-type thermocouple is a unique case since one of the conductors (copper) is the same metal as the internal DMM's input terminals. If another type of thermocouple is used, two additional thermocouples are created. For example, take a look at the connections with a J-type thermocouple (iron and constantan):

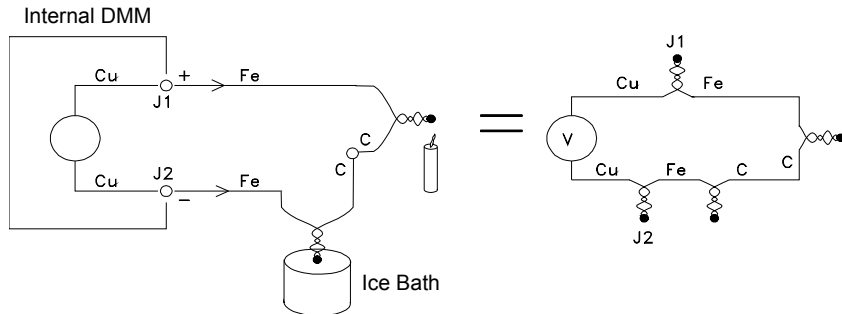

Two additional thermocouples have been created where the iron (Fe) lead connects to the internal DMM's copper (Cu) input terminals. Since these two junctions will generate opposing voltages, their effect will be to cancel each other. However, if the input terminals are not at the same temperature, an error will be created in the measurement.

To make a more accurate measurement, you should extend the copper test leads of the internal DMM closer to the measurement and hold the connections to the thermocouple at the same temperature.

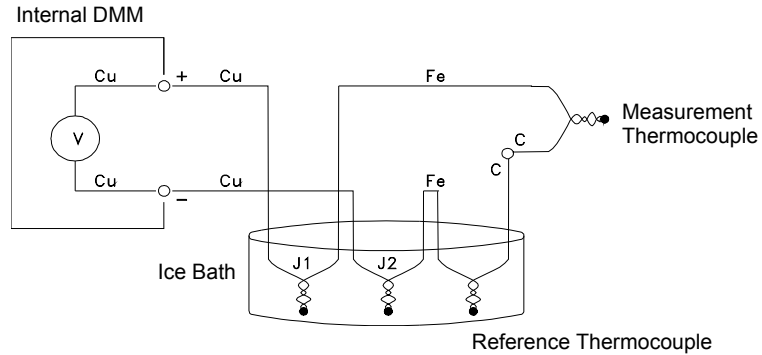

This circuit will give accurate temperature measurements. However, it is not very convenient to make two thermocouple connections and keep all connections at a known temperature. The *Law of Intermediate Metals* eliminates the need for the extra connection. This empirical law states that a third metal (iron (Fe) in this example) inserted between two dissimilar metals will have *no effect* upon the output voltage, provided the junctions formed are at the same temperature. Removing the reference thermocouple makes the connections much easier.

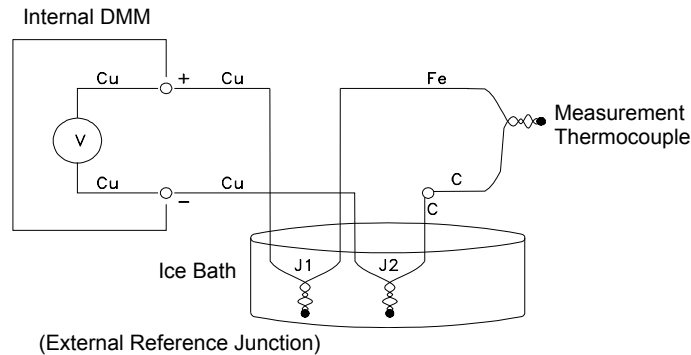

*This circuit is the best solution for accurate thermocouple connections.*

In some measurement situations, however, it would be nice to remove the need for an ice bath (or any other fixed external reference). To do this, an *isothermal block* is used to make the connections. An isothermal block is an electrical insulator, but a good heat conductor. The additional thermocouples created at J1 and J2 are now held at the same temperature by the isothermal block.

Once the temperature of the isothermal block is known, accurate temperature measurements can be made. A temperature sensor is mounted to the isothermal block to measure its temperature.

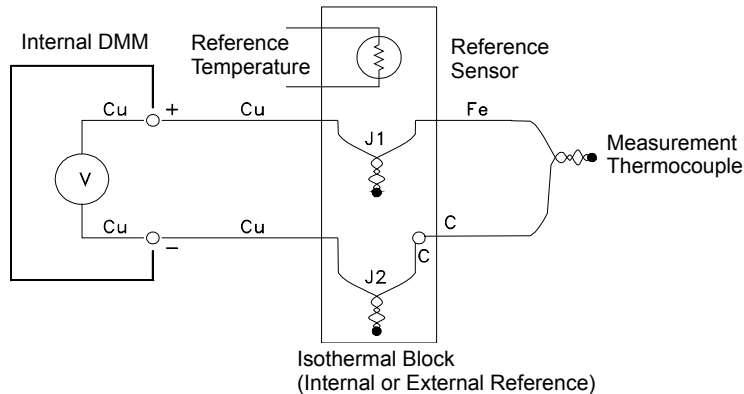

Thermocouples are available in a variety of types. The type is specified by a single letter. The table on the following page shows the most commonly used thermocouple types and some key characteristics of each.

**Note:** The thermocouple conversion routines used by the 34970A/34972A are compatible with the International Temperature Scale of 1990 (ITS-90).



*Thermocouple Types*

T/C Type	Pos (+) Lead	Neg (-) Lead	Temperature Range	Probe Accuracy	Comments
B U.S. British DIN Japanese French	<b>Platinum -30% Rhodium</b> Gray N/A Red Red N/A	<b>Platinum -60% Rhodium</b> Red N/A Gray Gray N/A	250°C - 1820°C	±0.5°C	High Temperature. Beware of contamination. Do not insert in metal tubes.
J U.S. British DIN Japanese French	<b>Iron</b> White Yellow Red Red Yellow	<b>Constantan</b> Red Blue Blue White Black	-210°C - 1200°C	±1.1°C - 2.2°C	For vacuum, inert environments. Least expensive. Not recommended for low temperature.
K U.S. British DIN Japanese French	<b>Nickel-Chromium</b> Yellow Brown Red Red Yellow	<b>Nickel-Aluminum</b> Red Blue Green White Purple	-200°C - 1370°C	±1.1°C - 2.2°C	For oxidizing environments. Good linearity above 8°C.
T U.S. British DIN Japanese French	<b>Copper</b> Blue White Red Red Yellow	<b>Constantan</b> Red Blue Brown White Blue	-200°C - 400°C	±0.5°C - 1°C	Withstands moisture. Has a copper lead. Low temperature applications.
E U.S. British DIN Japanese French	<b>Nickel-Chromium</b> Purple Brown Red Red Yellow	<b>Constantan</b> Red Blue Black White Blue	-200°C - 1000°C	±1°C - 1.7°C	Highest output voltage. Highest resolution.
N U.S. British DIN Japanese French	<b>Nicrosil</b> Orange N/A N/A N/A N/A	<b>Nisil</b> Red N/A N/A N/A N/A	-200°C - 1300°C	±1.1°C - 2.2°C	Superior stability to K type at higher temperatures
R U.S. British DIN Japanese French	<b>Platinum -13% Rhodium</b> Black White Red Red Yellow	<b>Rhodium</b> Red Blue White White Green	-50°C - 1760°C	±0.6°C - 1.5°C	High Temperature. Beware of contamination. Do not insert in metal tubes.
S U.S. British DIN Japanese French	<b>Platinum -10% Rhodium</b> Black White Red Red Yellow	<b>Platinum</b> Red Blue White White Green	-50°C - 1760°C	±0.6°C - 1.5°C	Low error, good stability. High temperature. Beware of contamination. Do not insert in metal tubes.

Constantan = Copper-Nickel; Nicrosil = Nickel-Chromium-Silicon; Nisil = Nickel-Silicone-Magnesium; N/A = Not Available

## Sources of Error in Thermocouple Measurements

**Reference Junction Error** A thermocouple is typically formed by welding or soldering two wires together to make the junction. Soldering introduces a third metal into the junction. Provided that both sides of the thermocouple are at the same temperature, the third metal has little effect.

Commercial thermocouples are welded using a capacitive-discharge technique. This technique is used to prevent overheating of the thermocouple wire near the junction and to prevent the diffusion of the welding gas and atmosphere into the thermocouple wire.

A poor weld or bad solder connection can also cause errors in a thermocouple measurement. Open thermocouple junctions can be detected by checking the resistance of the thermocouple. A resistance measurement of more than 5 k $\Omega$ . typically indicates a defective thermocouple. The 34970A/34972A contains a built-in, automatic *thermocouple check* feature. If you enable this feature, the instrument measures the channel resistance after each thermocouple measurement to ensure a proper connection. *For more information on using the thermocouple check feature, see page 124.*

**Diffusion Error** Diffusion in a thermocouple wire is the process of changing the alloy type along the wire itself. Atmospheric particles can actually diffuse into the metal. These changes in the wire alloy introduce small voltage changes in the measurement. Diffusion is caused by exposure to high temperatures along the wire or by physical stress to the wire such as stretching or vibration.

Temperature errors due to diffusion are hard to detect since the thermocouple will still respond to temperature changes and give nearly correct results. The diffusion effects are usually detected as a drift in the temperature measurements.

Replacing a thermocouple which exhibits a diffusion error may not correct the problem. The extension wire and connections are all subject to diffusion. Examine the entire measurement path for signs of temperature extremes or physical stress. If possible, keep the temperature gradient across the extension wire to a minimum.

**Shunt Impedance** The insulation used for thermocouple wire and extension wire can be degraded by high temperatures or corrosive atmospheres. These breakdowns appear as a resistance in parallel with the thermocouple junction. This is especially apparent in systems using a small gauge wire where the series resistance of the wire is high.

**Shielding** Shielding reduces the effect of *common mode* noise on a thermocouple measurement. Common mode noise is generated by sources such as power lines and electrical motors. The noise is coupled to the unshielded thermocouple wires through distributed capacitance. As the induced current flows to ground through the internal DMM, voltage errors are generated along the distributed resistance of the thermocouple wire. Adding a shield to the thermocouple wire will shunt the common mode noise to earth ground and preserve the measurement.

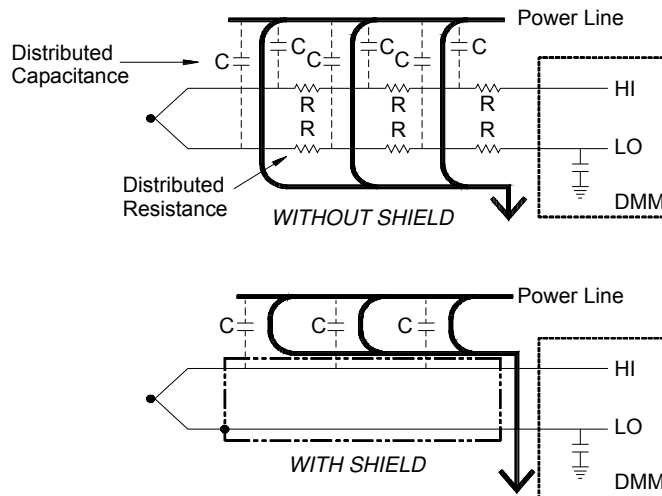

Common mode noise can dramatically affect the internal DMM. A typical thermocouple output is a few millivolts and a few millivolts of common mode noise can overload the input to the internal DMM.

**Calculation Error** An error is inherent in the way a thermocouple voltage is converted to a temperature. These calculation errors are typically very small compared to the errors of the thermocouple, wiring connections, and reference junction (*see page 267*).

## DC Voltage Measurements

To make a useful DC meter, a “front-end” is required to condition the input before the analog-to-digital conversion. Signal conditioning increases the input resistance, amplifies small signals, and attenuates large signals to produce a selection of measuring ranges.

**Signal Conditioning for DC Measurements** Input signal conditioning for DC voltage measurements includes both amplification and attenuation. A simplified input to the internal DMM is shown below.

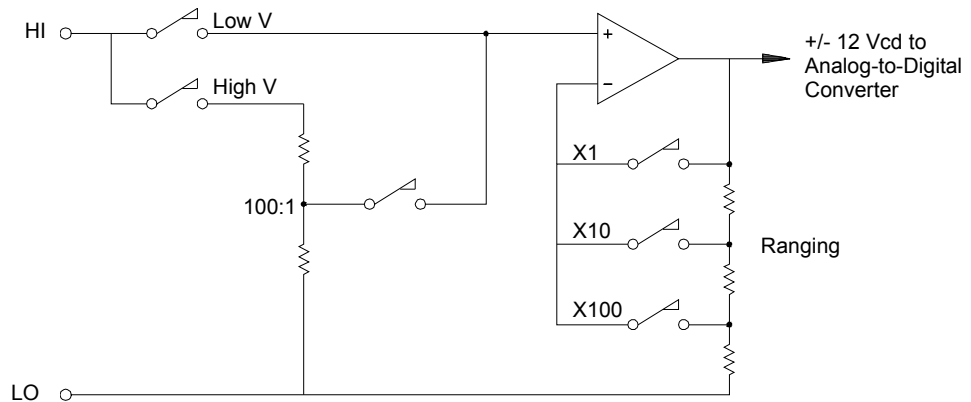

For input voltages less than 12 VDC, the Low V switch is closed and applies the input signal directly to the input amplifier. For higher voltages, the High V switch is closed and the signal is attenuated 100:1 before being applied to the input amplifier. The input amplifier gain is set to one of three values (x1, x10, or x100) to yield a signal in the range of  $\pm 12$  VDC for the analog-to-digital converter.

For the lower voltage ranges, the internal DMM's input resistance is essentially that of the input amplifier. The input amplifier uses a low-bias current (less than 50 pA) FET input stage yielding an input resistance greater than 10 G $\Omega$ . On the 100V and 300V input ranges, the input resistance is determined by the total resistance of the 100:1 divider. You can also set the input resistance to 10 M $\Omega$  by continuously closing the High V switch (*for more information on DC input resistance, see page 130*).

## Sources of Error in DC Voltage Measurements

**Common Mode Rejection** Ideally, the internal DMM is completely isolated from earth-referenced circuits. However, there is finite resistance and capacitance between the input LO terminal and earth ground. If the input terminals are both driven by an earth-referenced signal ( $V_f$ ) then a current will flow through  $R_S$  and create a voltage drop  $V_L$  as shown below.

Any resulting voltage ( $V_L$ ) will appear as an input to the internal DMM. As the value of  $R_S$  approaches zero, so does the error. Additionally, if  $V_f$  is at the power line frequency (50 Hz or 60 Hz), the noise can be greatly reduced by setting the internal DMM's integration time to 1 PLC or greater (see page 120 for a discussion of integration time).

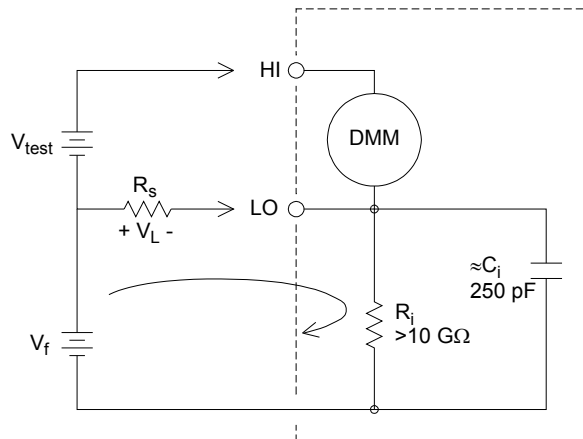

Where:

$V_f$  = Common mode float voltage

$R_S$  = LO lead resistance

$R_i$  = Isolation resistance

$C_i$  = Isolation capacitance

$Z_i$  = Parallel impedance of  $R_i + C_i$

$$\text{Error } (V_L) = \frac{V_f \times R_S}{R_S + Z}$$

**Noise Caused by Injected Current** Residual capacitances in the instrument's power transformer cause small currents to flow from the LO terminal of the internal DMM to earth ground. The frequency of the "injected current" is the power line frequency or possibly harmonics of the power line frequency. The injected current is dependent upon the power line configuration and frequency. A simplified circuit is shown below.

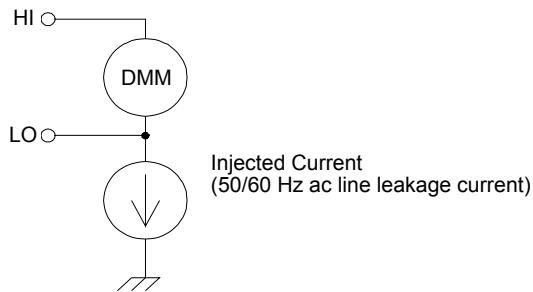

With *Connection A* (see below), the injected current flows from the earth connection provided by the circuit to the LO terminal of the internal DMM. This configuration adds no noise to the measurement. However, with *Connection B*, the injected current flows through the resistor R thus adding noise to the measurement. With *Connection B*, larger values of R will make the problem worse.

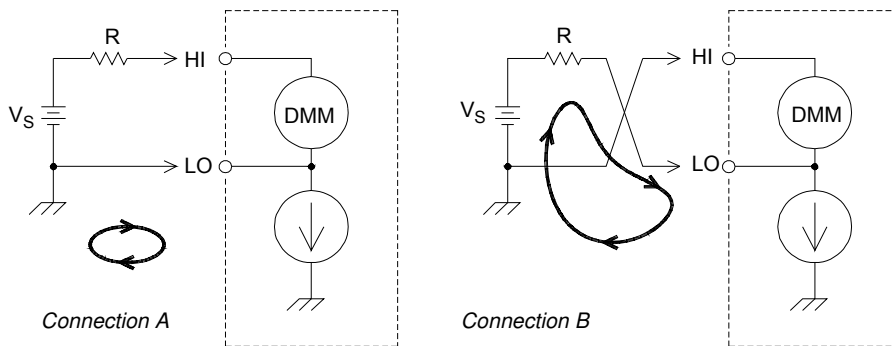

The measurement noise caused by injected current can be significantly reduced by setting the integration time of the internal DMM to 1 PLC or greater (see page 120 for a discussion of integration time).

**Loading Errors Due to Input Resistance** Measurement loading errors occur when the resistance of the device-under-test (DUT) is an appreciable percentage of the instrument's own input resistance. The diagram below shows this error source.

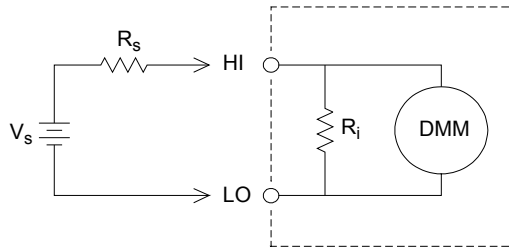

Where:

$V_s$  = Ideal DUT voltage

$R_s$  = DUT source resistance

$R_i$  = Input resistance (10 M $\Omega$  or > 10 G $\Omega$ )

$$\text{Error (\%)} = \frac{-100 \times R_s}{R_s + R_i}$$

To minimize loading errors, set the DMM's DC input resistance to greater than 10 G $\Omega$  when needed (*for more information on DC input resistance, see page 130*).

**Loading Errors Due to Input Bias Current** The semiconductor devices used in the input circuits of the internal DMM have slight leakage currents called *bias currents*. The effect of the input bias current is a loading error at the internal DMM's input terminals. The leakage current will approximately double for every 10 °C temperature rise, thus making the problem much more apparent at higher temperatures.

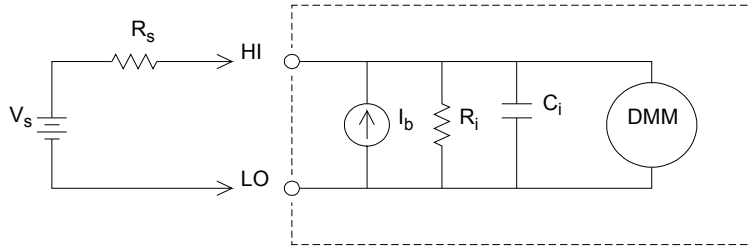

Where:

$I_b$  = DMM bias current

$R_s$  = DUT source resistance

$R_i$  = Input resistance (10 M $\Omega$  or > 10 G $\Omega$ )

$C_i$  = DMM input capacitance

$$\text{Error (V)} = I_b \times R_s$$



## AC Voltage Measurements

The main purpose of an AC “front end” is to change an AC voltage input into a DC voltage which can be measured by the ADC.

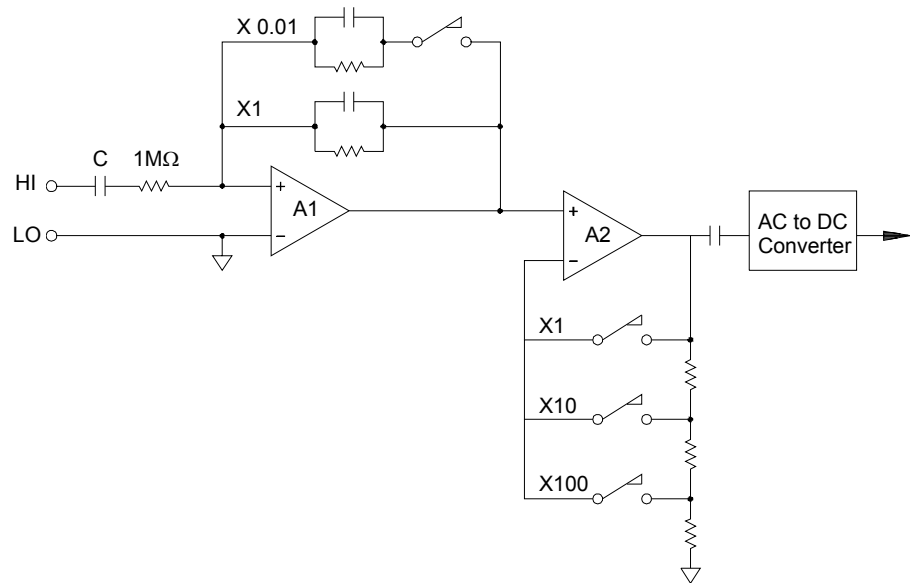

**Signal Conditioning for AC Measurements** Input signal conditioning for AC voltage measurements includes both attenuation and amplification. An input coupling capacitor (C) blocks the DC portion of the input signal so that only the AC component is measured. Ranging is accomplished by combining signal attenuation from the first-stage amplifier and gain from the second-stage amplifier.



The first stage implements a high input impedance (1 MΩ) switchable compensated attenuator. The second stage provides variable-gain signal amplification to scale the input to the AC converter to the full-scale level. Any residual DC offset from the attenuator and amplifier stages is blocked by a capacitor.

An AC voltage front end similar to the one discussed above is also used to measure AC current. Shunt resistors convert the AC current into an AC voltage which can then be measured. Current shunts are switched to provide selectable AC current ranges.

**True RMS AC Measurements** True RMS responding multimeters measure the “heating” potential of an applied voltage. Unlike an “average responding” measurement, a true RMS measurement is used to determine the power dissipated in a resistor. The power is proportional to the square of the measured true RMS voltage, independent of waveshape. An average responding AC multimeter is calibrated to read the same as a true RMS meter for *sinewave inputs only*. For other waveform shapes, an average responding meter will exhibit substantial errors as shown below.

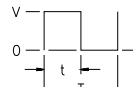
Waveform Shape	Crest Factor (C.F.)	AC RMS	AC+DC RMS	Average Responding Error
	1.414	$\frac{V}{1.414}$	$\frac{V}{1.414}$	Calibrated for 0 error
	1.732	$\frac{V}{1.732}$	$\frac{V}{1.732}$	-3.9%
	$\sqrt{\frac{T}{t}}$	$\frac{V}{C.F.} \times \sqrt{1 - \left(\frac{1}{C.F.}\right)^2}$	$\frac{V}{C.F.}$	-46% for C.F. = 4

The internal DMM’s AC voltage and AC current functions measure the ac-coupled true RMS value. This is in contrast to the ac+dc true RMS value shown above. Only the “heating value” of the AC component of the input waveform is measured (dc is rejected). For sinewaves, triangle waves, and square waves, the AC and AC+DC values are equal since these waveforms do not contain a DC offset. Non-symmetrical waveforms, such as pulse trains, contain DC voltages which are rejected by ac-coupled true RMS measurements.

An ac-coupled true RMS measurement is desirable in situations where you are measuring small AC signals in the presence of large DC offsets. For example, this situation is common when measuring AC ripple present on DC power supplies. There are situations, however, where you might want to know the ac+dc true RMS value. You can determine this value by combining results from DC and AC measurements as shown below. You should perform the DC measurement using at least 10 power line cycles of integration (6½ digit mode) for best AC rejection.

$$AC + DC = \sqrt{AC^2 + DC^2}$$

***Making High-Speed AC Measurements*** The internal DMM's AC voltage and AC current functions implement three low-frequency filters. These filters allow you to trade-off low frequency accuracy for faster scanning speed. The *fast filter* settles in 0.12 seconds and is useful for measurements above 200 Hz. The *medium filter* settles in 1 second and is useful for measurements above 20 Hz. The *slow filter* settles in 7 seconds and is useful for measurements above 3 Hz.

With a few precautions, you can perform AC measurements at speeds up to 100 readings per second (use manual ranging to eliminate autoranging delays). By setting the preprogrammed channel settling delays to zero, each filter will allow up to 100 channels per second. However, the measurement might not be very accurate since the filter is not fully settled. In scanning applications where sample-to-sample levels vary widely, the medium filter (20 Hz) will settle at 1 reading per second, and the fast filter (200 Hz) will settle at 10 readings per second.

If the sample-to-sample levels are similar, little settling time is required for each new reading. Under this specialized condition, the medium filter (20 Hz) will provide reduced accuracy results at 5 readings per second, and the fast filter (200 Hz) will provide reduced accuracy results at 50 readings per second. Additional settling time may be required when the DC level varies from sample to sample.

The internal DMM's DC blocking circuitry has a settling time constant of 0.2 seconds. This settling time only affects measurement accuracy when DC offset levels vary from sample to sample. If maximum measurement speed is desired in a scanning system, you may want to add an external DC blocking circuit to those channels with significant DC voltages present. This circuit can be as simple as a resistor and a capacitor.

AC Filter	Channel Delay	Settling Time
200 Hz (Fast)	AUTO	0.12 seconds
20 Hz (Medium)	AUTO	1 second
3 Hz (Slow)	AUTO	7 seconds
200 Hz (Fast)	0	0.02 seconds
20 Hz (Medium)	0	0.2 seconds
3 Hz (Slow)	0	1.5 seconds

*DC blocking settling time (1 time constant) = 0.2 seconds.*

## Sources of Error in AC Voltage Measurements

Many of the errors associated with DC voltage measurements also apply to AC voltage measurements. Additional errors unique to AC voltage measurements are described in this section.

**Crest Factor Errors (non-sinusoidal inputs)** A common misconception is that “since the internal DMM is true RMS, its sinewave accuracy specifications apply to all waveforms.” Actually, the shape of the input signal can dramatically affect measurement accuracy. A common way to describe signal waveshapes is *crest factor*. Crest factor is the ratio of the peak value to the RMS value of a waveform.

For a pulse train, for example, the crest factor is approximately equal to the square root of the inverse of the duty cycle as shown in the table on page 360. In general, the greater the crest factor the greater the energy contained in higher frequency harmonics. All multimeters exhibit measurement errors that are crest factor dependent. Crest factor errors are shown in the specifications in chapter 8. Note that the crest factor errors *do not* apply for input signals below 100 Hz when using the *slow* AC filter.

You can estimate the measurement error due to signal crest factor as shown below:

$$\text{Total Error} = \text{Error}_{\text{sine}} + \text{Error}_{\text{crest factor}} + \text{Error}_{\text{bandwidth}}$$

Where:

$$\text{Error}_{\text{sine}} = \text{DMM's sinewave accuracy (see Chapter 8, Specifications)}$$

$$\text{Error}_{\text{crest factor}} = \text{DMM's crest factor (see Chapter 8, Specifications)}$$

$$\text{Error}_{\text{bandwidth}} = \text{Estimated bandwidth error as shown below:}$$

$$\text{Error}_{\text{bandwidth}} = \frac{-\text{C.F.}^2 \times F}{4\pi \times \text{BW}}$$

Where:

$$\text{C.F.} = \text{Signal crest factor (see the table on page 282)}$$

$$F = \text{Fundamental input signal frequency}$$

$$\text{BW} = \text{DMM's -3 dB bandwidth (1 MHz for the 34970A/34972A)}$$

**Example: Calculating Measurement Error**

Calculate the approximate measurement error for a pulse train input with a crest factor of 3 and a fundamental frequency of 20 kHz. The internal DMM is set to the 1 V range. For this example, use the *90-day* accuracy specifications of  $\pm (0.05\%$  of reading +  $0.04\%$  of range), as shown in chapter 8.

$$\text{Error}_{\text{sine}} = \pm(0.05\% + 0.04\%) = \pm 0.09\%$$

$$\text{Error}_{\text{crest factor}} = 0.15\%$$

$$\text{Error}_{\text{bandwidth}} = \frac{-3^2 \times 20000}{4 \times 3.14159 \times 1000000} * 100 = 1.4\%$$

$$\text{Total Error} = 0.09\% + 0.15\% + 1.4\% = 1.6\%$$

**AC Loading Errors** In the AC voltage function, the input of the internal DMM appears as a 1 M $\Omega$  resistance in parallel with 150 pF of capacitance. The cabling that you use to connect signals to the instrument will also add additional capacitance and loading. The table below shows the approximate input resistance at various frequencies.

Input Frequency	Input Resistance
100 Hz	700 k $\Omega$
1 kHz	600 k $\Omega$
10 kHz	100 k $\Omega$
100 kHz	10 k $\Omega$

For low frequencies:

$$\text{Error (\%)} = \frac{-100 \times R_s}{R_s + 1 \text{ M}\Omega}$$

Additional error for high frequencies:

$$\text{Error (\%)} = 100 \times \left[ \frac{1}{\sqrt{1 + (2\pi \times F \times R_s \times C_{in})^2}} - 1 \right]$$

F = Input frequency

R<sub>s</sub> = Source resistance

C<sub>in</sub> = Input capacitance (150 pF) + Cable capacitance

*Use low-capacitance cable when measuring high-frequency AC signals (see page 258).*

***Low-Level AC Measurement Errors*** When measuring AC voltages less than 100 mV, be aware that these measurements are especially susceptible to errors introduced by extraneous noise sources. An exposed test lead will act as an antenna and the internal DMM will measure the signals received. The entire measurement path, including the power line, act as a loop antenna. Circulating currents in the loop will create error voltages across any impedances in series with the instrument's input. For this reason, you should apply low-level AC voltages to the instrument through shielded cables. You should also connect the shield to the input LO terminal.

Be sure to minimize the area of any ground loops that cannot be avoided. A high-impedance source is more susceptible to noise pickup than a low-impedance source. You can reduce the high-frequency impedance of a source by placing a capacitor in parallel with the instrument's input terminals. You may have to experiment to determine the correct capacitance value for your application.

Most extraneous noise is not correlated with the input signal. You can determine the error as shown below.

$$\text{Voltage Measured} = \sqrt{V_{\text{in}}^2 + \text{Noise}^2}$$

Correlated noise, while rare, is especially detrimental. Correlated noise will always add directly to the input signal. Measuring a low-level signal with the same frequency as the local power line is a common situation that is prone to this error.

You should use caution when switching high-level and low-level signals on the same module. It is possible that high-level charged voltages may be discharged onto a low-level channel. It is recommended that you either use two different modules or separate the high-level signals from the low-level signals with an unused channel connected to ground.

***Measurements Below Full Scale*** You can make the most accurate AC measurements when the internal DMM is at full scale of the selected range. Autoranging occurs at 10% and 120% of full scale. This enables you to measure some inputs at full scale on one range and 10% of full scale on the next higher range. Note that the measurement accuracy will be significantly different for the two cases. For highest accuracy, you should use *manual ranging* to select the lowest range possible for the measurement.

***Temperature Coefficient and Overload Errors*** The internal DMM uses an AC measurement technique that periodically measures and removes internal offset voltages when you select a different function or range. When manual ranging to a new range in an *overload condition*, the internal offset measurement may be degraded for the selected range. Typically, an additional 0.01% of range error may be introduced. This additional error will remain until the next periodic removal (typically 15 minutes).



## Current Measurements

*Current measurements are allowed only on the 34901A module.*

An ammeter senses the current flowing through its input connections – approximating a short circuit between its input terminals. An ammeter must be connected in series with the circuit or device being measured such that current flows through both the meter and the test circuit.

A resistor,  $R_s$  in the diagram below, is connected across the input terminals such that a voltage drop proportional to the input current is generated. The value of  $R_s$  is selected as low as possible to minimize the instrument's *burden voltage*, or  $IR$  drop. This voltage drop is sensed by the internal DMM and scaled to the proper current value to complete the measurement (*see the discussion on the following page*).

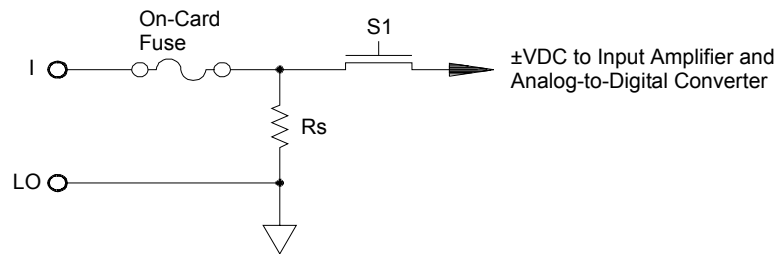

AC current measurements are very similar to DC current measurements. The output of the current-to-voltage sensor is measured by an AC voltmeter. The input terminals are direct coupled (ac+dc coupled) to the shunt so that the internal DMM maintains DC continuity in the test circuit. Performing AC current measurements demands additional care. The *burden voltage* (loading) varies with frequency and input inductance, often causing unexpected behavior in the test circuit (*see the discussion on the following page*).

## Sources of Error in DC Current Measurements

When you connect the internal DMM in series with a test circuit to measure current, a measurement error is introduced. The error is caused by the DMM's series *burden voltage*. A voltage is developed across the wiring resistance and current shunt resistance of the internal DMM as shown below.

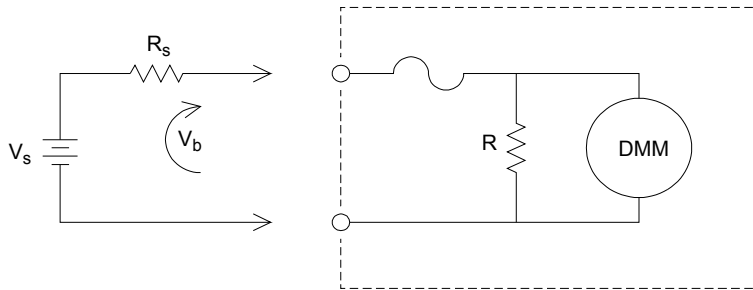

$V_s$  = Source voltage  
 $R_s$  = Source resistance  
 $V_b$  = Burden voltage  
 $R$  = Current shunt resistance

$$\text{Error (\%)} = \frac{-100\% \times V_b}{V_s}$$

## Sources of Error in AC Current Measurements

Burden voltage errors, which apply to DC current, also apply to AC current measurements. However, the burden voltage for AC current is larger due to the internal DMM's series inductance and the measurement connections. The burden voltage increases as the input frequency increases. Some circuits may oscillate when performing current measurements due to the internal DMM's series inductance and the measurement connections.

## Resistance Measurements

An ohmmeter measures the DC resistance of a device or circuit connected to its input. Resistance measurements are performed by supplying a known DC current to an unknown resistance and measuring the DC voltage drop.

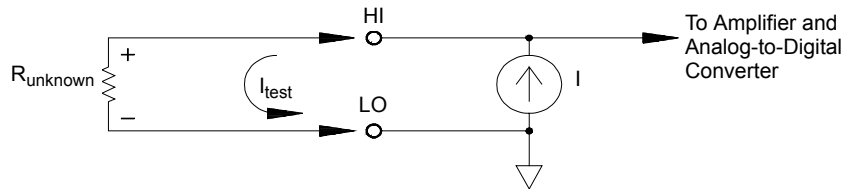

The internal DMM offers two methods for measuring resistance: *2-wire* and *4-wire* ohms. For both methods, the test current flows from the input HI terminal through the resistor being measured. For 2-wire ohms, the voltage drop across the resistor being measured is sensed internal to the DMM. Therefore, test lead resistance is also measured. For 4-wire ohms, separate “sense” connections are required. Since no current flows in the sense leads, the resistance in these leads does not give a measurement error.

**4-Wire Ohms Measurements** The 4-wire ohms method provides the most accurate way to measure small resistances. Test lead, multiplexer, and contact resistances are automatically reduced using this method. The 4-wire ohms method is often used in automated test applications where long cable lengths, input connections, and a multiplexer exist between the internal DMM and the device-under-test.

The recommended connections for 4-wire ohms measurements are shown in the diagram on the following page. A constant current source, forcing current  $I$  through unknown resistance  $R$ , develops a voltage measured by a DC voltage front end. The unknown resistance is then calculated using *Ohm’s Law*.

Chapter 7 Tutorial  
**Measurement Fundamentals**

The 4-wire ohms method is used in systems where lead resistances can become quite large and variable and in automated test applications where cable lengths can be quite long. The 4-wire ohms method has the obvious disadvantage of requiring twice as many switches and twice as many wires as the 2-wire method. The 4-wire ohms method is used almost exclusively for measuring lower resistance values in any application, especially for values less than  $10\Omega$  and for high-accuracy requirements such as RTD temperature transducers.

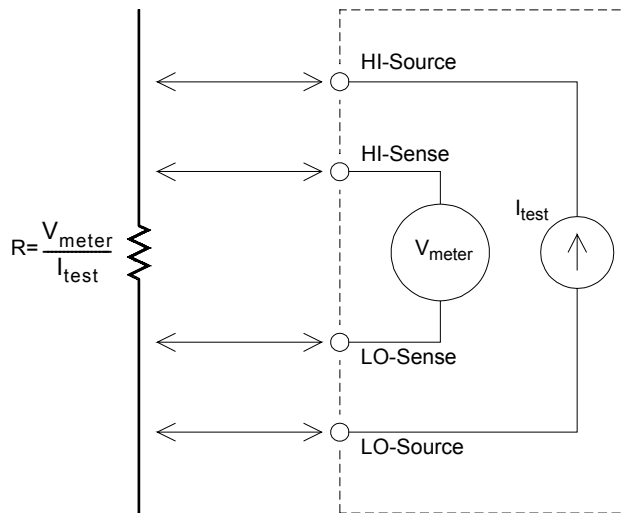

**Offset Compensation** Most connections in a system use materials that produce small DC voltages due to dissimilar metal-to-metal contact (thermocouple effect) or electrochemical batteries (*for a description of the thermocouple effect, see page 262*). These DC voltages also add errors to resistance measurements. The offset-compensated measurement is designed to allow resistance measurements in the presence of small DC voltages.

Offset compensation makes two measurements on the circuit connected to the input channel. The first measurement is a conventional resistance measurement. The second is the same except the internal DMM's test current source is turned off (essentially a normal DC voltage measurement). The second measurement is subtracted from the first prior to scaling the result, thus giving a more accurate resistance measurement. *Refer to "Offset Compensation" on page 132 for more information.*

Offset compensation can be used for 2-wire or 4-wire ohms measurements (but not for RTD or thermistor measurements). The 34970A/34972A disables offset compensation when the measurement function is changed or after a Factory Reset (\*RST command). An Instrument Preset (SYSTEM:PRESet command) or Card Reset (SYSTEM:CPON command) *does not* change the setting.

If the resistor being measured does not respond quickly to changes in current, offset compensation *will not* produce an accurate measurement. Resistors with very large inductances or resistors with large parallel capacitance would fall into this category. In these cases, the channel delay parameter can be increased to allow more settling time after the current source is switched on or off, or offset compensation can be turned off. *For more information on channel delay, see page 105.*

## Sources of Error in Resistance Measurements

**External Voltages** Any voltages present in the system cabling or connections will affect a resistance measurement. The effects of some of these voltages can be overcome by using offset compensation (*as described on the previous page*).

**Settling Time Effects** The internal DMM has the ability to insert automatic measurement settling delays. These delays are adequate for resistance measurements with less than 200 pF of combined cable and device capacitance. This is particularly important if you are measuring resistances above 100 k $\Omega$ . Settling due to RC time constant effects can be quite long. Some precision resistors and multifunction calibrators use large parallel capacitances (1000 pF to 0.1  $\mu$ F) with high resistance values to filter out noise currents injected by their internal circuitry. Non-ideal capacitances due to dielectric absorption (soak) effects in cables and other devices may have much longer settling times than expected just by RC time constants. Errors will be measured when settling after the initial connection, after a range change, or when using offset compensation. You may need to increase the channel delay time before a measurement in these situations (*for more information on channel delay, see page 105*).

**High-Resistance Measurement Errors** When you are measuring large resistances, significant errors can occur due to insulation resistance and surface cleanliness. You should take the necessary precautions to maintain a “clean” high-resistance system. Test leads and fixtures are susceptible to leakage due to moisture absorption in insulating materials and “dirty” surface films. Nylon and PVC are relatively poor insulators ( $10^9$  ohms) when compared to PTFE insulators ( $10^{13}$  ohms). Leakage from nylon or PVC insulators can easily contribute a 0.1% error when measuring a 1 M $\Omega$  resistance in humid conditions. The table below shows several common insulating materials and their typical resistances.

Insulating Material	Resistance Range	Moisture Absorbing
PTFE	1 T $\Omega$ to 1 P $\Omega$	N
Nylon	1 G $\Omega$ to 10 T $\Omega$	Y
PVC	10 G $\Omega$ to 10 T $\Omega$	Y
Polystyrene	100 G $\Omega$ to 1 P $\Omega$	N
Ceramic	1 G $\Omega$ to 1 P $\Omega$	N
Glass Epoxy (FR-4, G-10)	1 G $\Omega$ to 10 T $\Omega$	Y
Phenolic, Paper	10 M $\Omega$ to 10 G $\Omega$	Y

## Strain Gage Measurements

Although the instrument does not directly support strain measurements, you can measure a strain gage using a 4-wire resistance measurement with scaling. However, *BenchLink Data Logger 3* software has built-in strain gage measurement capability.

When a force is applied to a body, the body deforms. The deformation per unit length is called *strain* ( $\epsilon$ ). Strain may be either tensile (+) or compressive (-). Practical strain values are usually quite small (typically less than 0.005 inch/inch for most metals) and are often expressed in micro-strains ( $\mu\epsilon$ ). There are three common types of strain measurements as shown below.

*Normal Strain* ( $\epsilon$ ) is a measure of the deformation along the axis of the applied force.  $\epsilon = \Delta L/L$

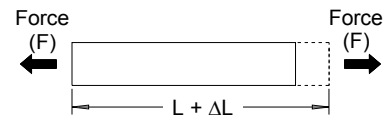

*Shearing Strain* ( $\gamma$ ) is a measure of the angular distortion of a body. It is approximated by the tangent of the angle formed by the angular change between two line segments that were parallel in the undeformed state.

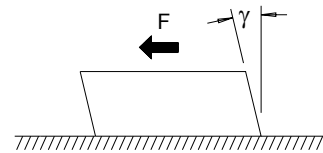

*Poisson Strain* ( $\nu$ ) measures a property of materials known as the *Poisson Ratio*. It is the negative ratio of transverse and longitudinal normal strain when a body has a longitudinal tensile force applied.  $\nu = -\epsilon_t/\epsilon$ , where  $\epsilon_t = \Delta D/D$  and  $\epsilon = \Delta L/L$

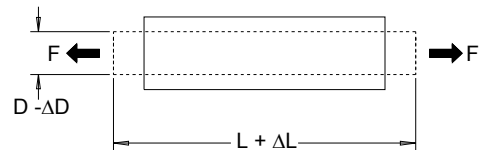

**Stress** Stress is a term used to compare the loading applied to a material with its ability to carry the load. Stress ( $\sigma$ ) in a material can not be measured directly; it must be computed from material properties and measurable quantities such as strain and force.

**Strain Sensors** The metal foil resistance strain gage is by far the most widely used strain measurement sensor. It consists of a thin metallic foil grid bonded to a thin insulating, adhesive backing. The resistance of the foil varies linearly with strain. Strain in the test body is simply the ratio of the foil's strained to unstrained resistance:  $\epsilon = \Delta R / R$ .

The *Gage Factor* (GF) indicates the sensitivity of a strain gage and is a measure of the fractional resistance change per strain:  $GF = (\Delta R / R) / \epsilon$ . Devices with a higher gage factor will exhibit a greater resistance change per strain applied.

Strain gages are available in many patterns with various numbers and configurations of elements. The most common element is the single gage form shown below. Multi-element strain gages, also called *rosettes*, are used to measure components of strain in different directions. Two-element (90°) and three-element (45° or 60°) configurations are the most common.

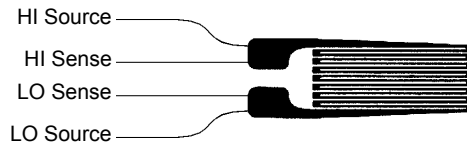

**Common Uses for Strain Gages** Strain gages are used to sense many types of physical parameters. Strain gages are primarily a force-sensing device. Force is measured indirectly by measuring the deformation of a test body to a known applied force thus producing a resistance change proportional to the applied force. Many other physical quantities can be measured through force measurements. Common applications of strain gages include weight, pressure, flow, and level measurements.



**Making Strain Gage Measurements** A *Wheatstone bridge* is commonly used to enable instruments with low-sensitivity measuring capabilities to measure small resistance changes common in strain measurements. Instruments with high-resolution resistance measuring capabilities, like the 34970A/34972A internal DMM, can directly measure small resistance changes with high precision and linearity. You should also use the 4-wire resistance method when measuring strain gages to eliminate system cabling errors.

An initial, unstrained, gage resistance measurement is used as the reference ( $R_0$ ) measurement from which strain ( $\Delta R / R_0$ ) is measured. For best results, you should perform this reference measurement after the strain gage has been mounted to the test body. The table below shows the resistance changes corresponding to 1  $\mu\epsilon$  strain for common gage factor and unstrained gage resistance values.

Strain	GF	$R_0$	$\Delta R$	DMM Sensitivity
1 $\mu\epsilon$	2.0	120 $\Omega$	0.24 m $\Omega$	0.1 m $\Omega$ (0.4 $\mu\epsilon$ )
1 $\mu\epsilon$	2.0	350 $\Omega$	0.70 m $\Omega$	1.0 m $\Omega$ (1.4 $\mu\epsilon$ )
1 $\mu\epsilon$	2.0	1000 $\Omega$	2.0 m $\Omega$	1.0 m $\Omega$ (0.5 $\mu\epsilon$ )

Using the  $Mx+B$  scaling function with the equations shown below will allow you to display results directly in strain on the 34970A/34972A front-panel display. You can use a custom measurement label to display readings in “ $\mu\epsilon$ ” (micro-strain) directly. The instrument will automatically add the micro (“ $\mu$ ”) prefix based upon actual calculated values. *For more information on scaling, see page 136.*

$$M = \frac{1}{GF \times R_0} \quad B = -\frac{1}{GF}$$

**Temperature Effects** The resistive element of a strain gage will produce a resistance change  $\Delta R$  due to measured strain as well as changes in gage temperature. This will create an “apparent” strain change which is undesirable. A second gage of similar type can be used to detect temperature changes and thus remove this error source. You should mount the second gage in close proximity and at 90° to the first gage, thus responding to local temperature changes but rejecting strain changes. Subtracting measurements from the second gage will remove any undesirable strain errors.

## Frequency and Period Measurements

The internal DMM uses a reciprocal counting technique to measure frequency and period. This method generates constant measurement resolution for any input frequency. The internal DMM's AC voltage measurement section performs input signal conditioning for frequency and period measurements.

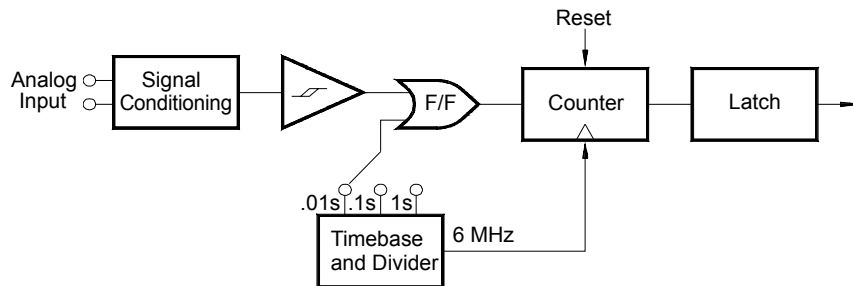

The timebase is divided to provide a gate signal. The gate signal and input signal are combined to enable the counter. During the “on” time, the counter counts the 6 MHz timebase signal. At the end of each gate period, the total count is latched and the result is divided by the known timebase frequency to determine the input frequency. The counter is then reset before the next gate period. The resolution of the measurement is tied to the timebase, and not the input frequency. This increases measurement speed especially at low frequencies.

The reciprocal counter has the advantage of a constant number of digits of display, no matter what the input frequency is. With a reciprocal counter, the number of digits of resolution scales with the gate time. If a 1-second gate gives six digits of resolution, a 0.1-second gate gives five digits, and so forth.

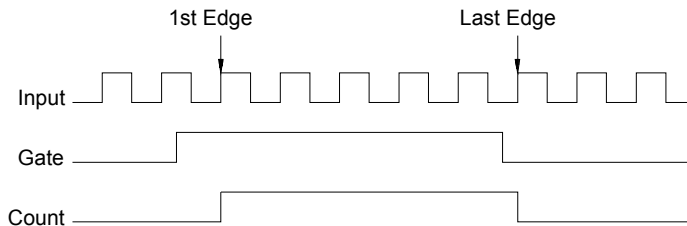

***Sources of Error in Frequency and Period Measurements***

The internal DMM's AC voltage measurement section performs input signal conditioning. All frequency counters are susceptible to errors when measuring low-voltage, low-frequency signals. The effects of both internal noise and external noise pickup are critical when measuring "slow" signals. The error is inversely proportional to frequency. Measurement errors will also occur if you attempt to measure the frequency (or period) of an input following a DC offset voltage change. You must allow the internal DMM's input DC blocking capacitor to fully settle before making frequency measurements.

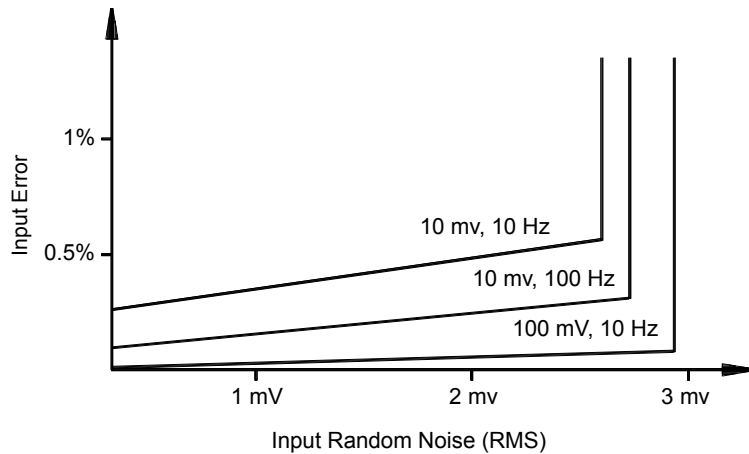

If the external noise pickup becomes large enough to exceed the hysteresis of the measuring circuitry, the frequency function may actually become unusable. External shielding and low-pass filtering may help.

## Low-Level Signal Multiplexing and Switching

Low-level multiplexers are available in the following types: *one-wire*, *2-wire*, and *4-wire*. The following sections in this chapter describe each type of multiplexer. The following low-level multiplexer modules are available with the 34970A.

- 34901A 20-Channel Armature Multiplexer
- 34902A 16-Channel Reed Multiplexer
- 34908A 40-Channel Single-Ended Multiplexer

An important feature of a multiplexer used as a DMM input channel is that only one channel is connected at a time. For example, using a multiplexer module and the internal DMM, you could configure a voltage measurement on channel 1 and a temperature measurement on channel 2. The instrument first closes the channel 1 relay, makes the voltage measurement, and then opens the relay before moving on to channel 2 (called *break-before-make* switching).

Other low-level switching modules available with the 34970A/34972A include the following:

- 34903A 20-Channel Actuator
- 34904A 4x8 Two-Wire Matrix

## One-Wire (Single-Ended) Multiplexers

On the 34908A multiplexer, all of the 40 channels switch the HI input only, with a common LO for the module. The module also provides a thermocouple reference junction for making thermocouple measurements (*for more information on the purpose of an isothermal block, see page 272*).

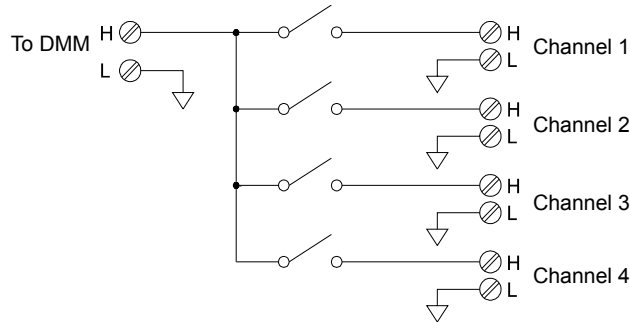

Note: Only one channel can be closed at a time; closing one channel will open the previously closed channel.

## Two-Wire Multiplexers

The 34901A and 34902A multiplexers switch both HI and LO inputs, thus providing fully isolated inputs to the internal DMM or an external instrument. These modules also provide a thermocouple reference junction for making thermocouple measurements (*for more information on the purpose of an isothermal block, see page 272*).

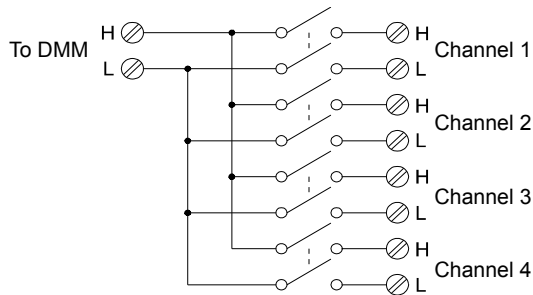

Note: If any channels are configured to be part of the scan list, you cannot close multiple channels; closing one channel will open the previously closed channel.

## Four-Wire Multiplexers

You can make 4-wire ohms measurements using the 34901A and 34902A multiplexers. For a 4-wire ohms measurement, the channels are divided into two independent banks by opening the bank relay.

For 4-wire measurements, the instrument automatically pairs channel  $n$  with channel  $n+10$  (34901A) or  $n+8$  (34902A) to provide the source and sense connections. For example, make the *source* connections to the HI and LO terminals on channel 2 and the *sense* connections to the HI and LO terminals on channel 12.

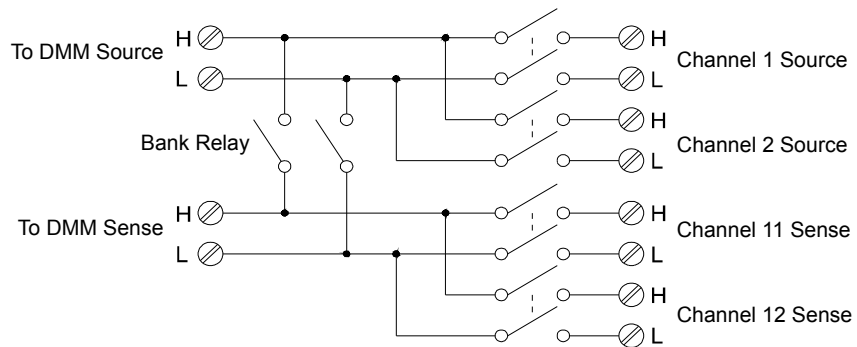

Note: If any channels are configured to be part of the scan list, you cannot close multiple channels; closing one channel will open the previously closed channel.

When making a 4-wire measurement, the test current flows through the *source* connections from the HI terminal through the resistor being measured. To eliminate the test lead resistance, a separate set of *sense* connections are used as shown below.

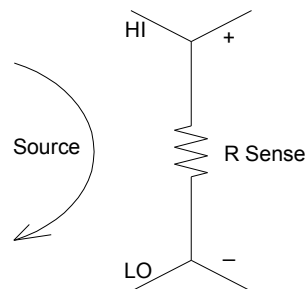

## Signal Routing and Multiplexing

When used stand-alone for signal routing (not scanning or connected to the internal DMM), multiple channels on the 34901A and 34902A multiplexers can be closed at the same time. You must be careful that this does not create a hazardous condition (for example, connecting two power sources together).

Note that a multiplexer *is not* directional. For example, you can use a multiplexer with a source (such as a DAC) to connect a single source to multiple test points as shown below.

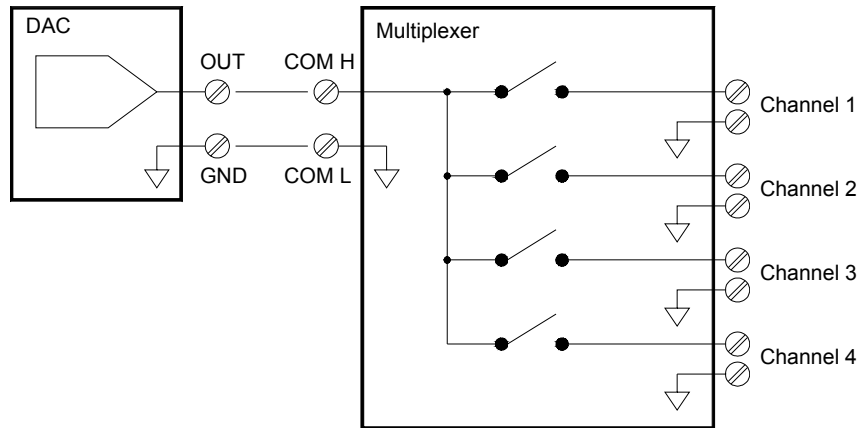

## Sources of Error in Multiplexing and Switching

Noise can be coupled inside a switch by the drive circuitry, by switch thermal EMFs, or by coupling among signal paths. Noise can also be generated outside the network and conducted or coupled into the switch. Although noise problems apply to the entire system, they can become especially acute for switching. Switch networks contain a high concentration of signals, which magnify the errors. Most problems with electric noise can be traced to improper grounding and shielding (*for more information on grounding and shielding, see page 259*).

Noise can be capacitively coupled between physically adjacent channels in a switching system. Noise can be coupled between the switch contacts themselves ( $C_{sw}$ ) or between adjacent cabling ( $C_{adj}$ ).

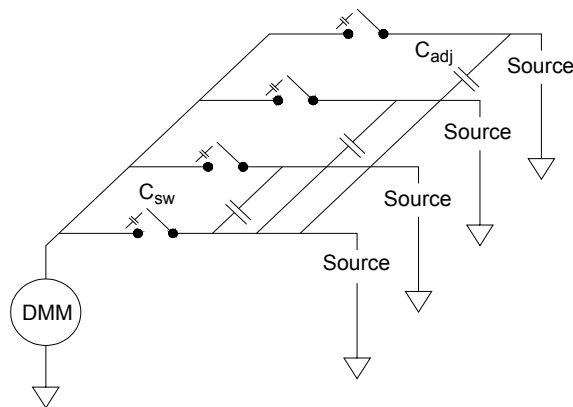

Capacitive noise coupling is a function of area and proximity. A simple method to reduce the noise coupling is to physically separate the switches and cables from each other. However, this may not be practical for all applications.

Another solution is to keep large amplitude signals and small amplitude signals away from each other. Group similar signals together (high voltages, low voltages, analog, and digital). If possible, use two separate switch modules; one for high-level signals and one for low-level signals. If you are using a single module for mixed-signal switching, leave one unused, grounded channel between the groups. Also, ground any unused channels on the module.



The 34901A and 34902A multiplexers have an additional relay, called a *bank switch* or *tree switch*, which helps reduce channel-to-channel noise ( $C_{adj}$ ). The multiplexer channels are divided into two banks. The bank switch isolates one bank of channels from the other, effectively removing any parallel adjacent capacitance from the isolated bank. During a scan, the instrument automatically controls the bank switches.

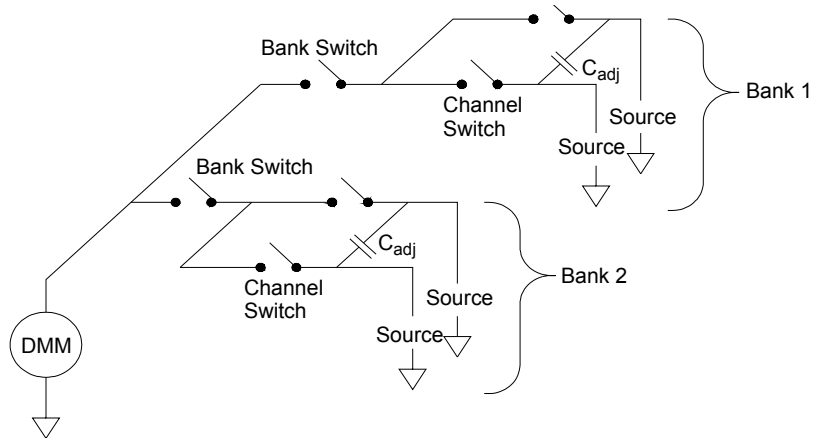

If you are not using all of the channels on the multiplexer, divide the input signals equally between Bank 1 and Bank 2. For example, if you are multiplexing eight channels using the 16-channel multiplexer, use four channels in the lower bank and four channels in the upper bank. For even better noise immunity, leave one unused, grounded channel between each input channel.

Module	Bank 1	Bank 2
34901A	Channels 1 through 10	Channels 11 through 20
34902A	Channels 1 through 8	Channels 9 through 16
34908A	Channels 1 through 20	Channels 21 through 40

## Actuators and General-Purpose Switching

The 34903A Actuator provides 20 independent, isolated SPDT (*single-pole, double-throw*) or Form C switches. This module offers simple on-off switching which you can use to control power devices or for custom switching applications. For example, you can use an actuator to build a simple resistance ladder as shown below.

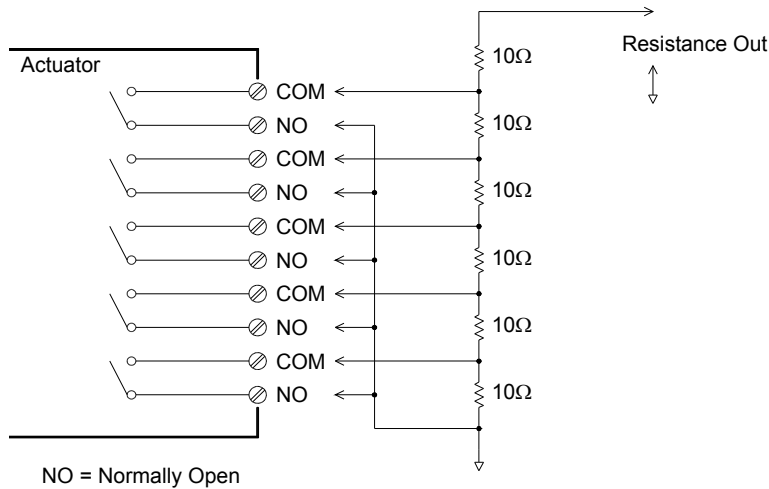

In the above diagram, the resistance is  $60\Omega$  when all of the actuator channels are open (not connected to COM). Note that when the actuator channels are open, as shown above, the normally-closed contacts (*not shown above*) are connected to COM. Values from  $10\Omega$  to  $50\Omega$  are selected by closing the appropriate channel(s) on the module.

## Snubber Circuits

Whenever a relay contact opens or closes, electrical breakdown or arcing can occur between the contacts. This can cause high-frequency noise radiation, voltage and current surges, and physical damage to the relay contacts.

A breadboard area is provided on the 34903A to implement custom circuitry such as simple filters, snubbers, and voltage dividers. The breadboard area provides the space necessary to insert your own components but there are no circuit board traces here. You can build these networks to provide contact protection when actuating AC power line for reactive loads. Although many types of contact protection networks can be used, only RC networks and varistors are described in this section.

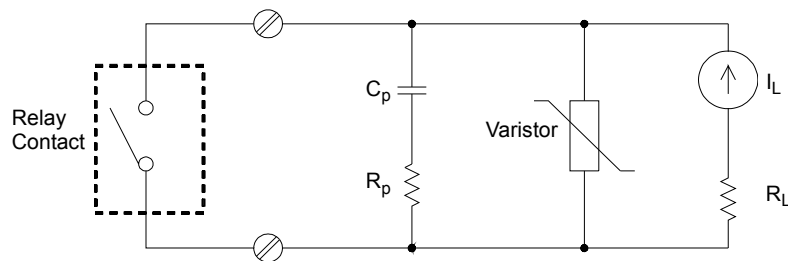

## RC Protection Networks

When designing RC protection networks, the protection resistor  $R_p$  is selected as a compromise between two resistance values. The minimum value of  $R_p$  is determined by the maximum acceptable relay contact current ( $I_{max}$ ). For the 34903A, the maximum allowable relay current ( $I_{max}$ ) is 1A DC or AC rms. Thus, the minimum value for  $R_p$  is  $V/I_o$ , where  $V$  is the peak value of the supply voltage.

$$R_p = \frac{V}{I_{max}} = \frac{V}{2}$$

The maximum value for  $R_p$  is usually made equal to the load resistance  $R_L$ . Therefore, the limits on  $R_p$  can be stated as:

$$\frac{V}{I_{\max}} < R_p < R_L$$

Note that the actual value of the current ( $I_o$ ) in a circuit is determined by the equation:

$$I_o = \frac{V}{R_L}$$

Where  $V$  is the peak value of the source voltage and  $R_L$  is the resistance of the load. The value for  $I_o$  will be used to determine the value of the protection capacitor ( $C_p$ ).

In determining the value of the protection network capacitor ( $C_p$ ), there are several things that you will need to consider. First, the total circuit capacitance ( $C_{\text{tot}}$ ) must be such that the peak voltage across the open relay contacts does not exceed 300 Vrms. The equation for determining the minimum allowable circuit capacitance is:

$$C_{\text{tot}} \geq (I_o/300)^2 \times L$$

where  $L$  is the inductance of the load and  $I_o$  is the current value calculated earlier.

The total circuit capacitance ( $C$ ) is actually made up of the wiring capacitance plus the value of the protection network capacitor  $C_p$ . Therefore, the minimum value for  $C_p$  should be the value obtained for the total circuit capacitance ( $C$ ). Note that the actual value used for  $C_p$  should be substantially greater than the value calculated for  $C$ .

## Using Varistors

Use a varistor to add an absolute voltage limit across the relay contacts. Varistors are available for a wide range of voltage and clamp energy ratings. Once the circuit reaches the voltage rating of the varistor, the varistor's resistance declines rapidly. A varistor can supplement an RC network and is especially useful when the required capacitance ( $C_p$ ) is too large.

## Using Attenuators

Provisions have been made on the 34903A circuit board for installing simple attenuators or filter networks. An attenuator is composed of two resistors that act as a voltage divider. A typical attenuator circuit is shown below.

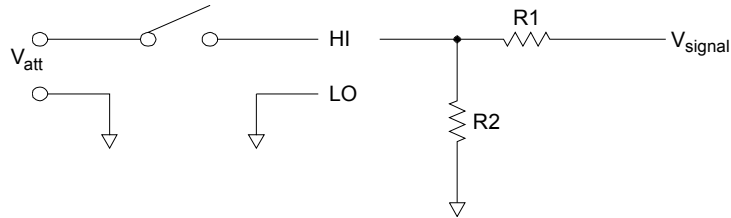

To select the attenuator components, use the following equation:

$$V_{\text{att}} = V_{\text{signal}} \times \frac{R_2}{R_1 + R_2}$$

One typical use for the shunt component is with 4 to 20 mA transducers. A 50Ω, ±1%, 0.5 watt resistor can be installed in the R2 location. The resultant voltage drop (transducer current through the resistor) can be measured by the internal DMM. Thus, the 50Ω resistor converts the 4 to 20 mA current to a 0.2 to 1 volt signal.

---

## Matrix Switching

A matrix switch connects multiple inputs to multiple outputs and therefore offers more switching flexibility than a multiplexer. Use a matrix for switching low-frequency (less than 10 MHz) signals only. A matrix is arranged in rows and columns. For example, a simple 3x3 matrix could be used to connect three sources to three test points as shown below.

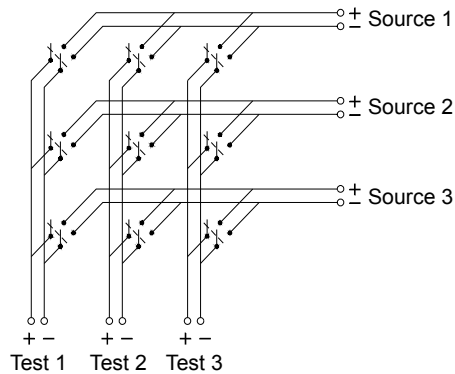

Any one of the signal sources can be connected to any one of the test inputs. Be aware that with a matrix, it is possible to connect more than one source at the same time. It is important to make sure that dangerous or unwanted conditions are not created by these connections.

## Combining Matrices

You can combine two or more matrix switches to provide more complex switching. For example, the 34904A provides a 4-row by 8-column matrix. You can combine two of these modules as either a 4-row by 16-column matrix or an 8-row by 8-column matrix. An 8x8 matrix is shown below.

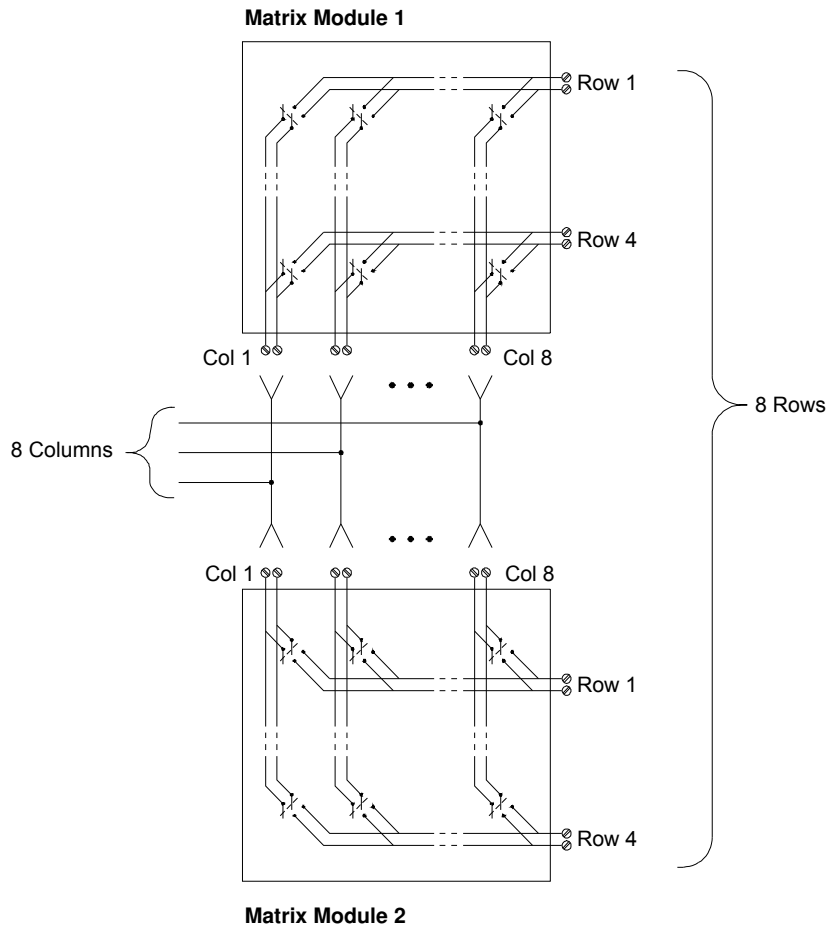

---

## RF Signal Multiplexing

A special type of multiplexer is the RF multiplexer. This type of multiplexer uses special components to maintain a  $50\Omega$  or  $75\Omega$  impedance in the signal line being switched. In a test system, these switches are often used to route a test signal from a signal source to the device-under-test. The switches are bi-directional. The diagram below shows two examples of a 4-to-1 channel RF multiplexer in a test system.

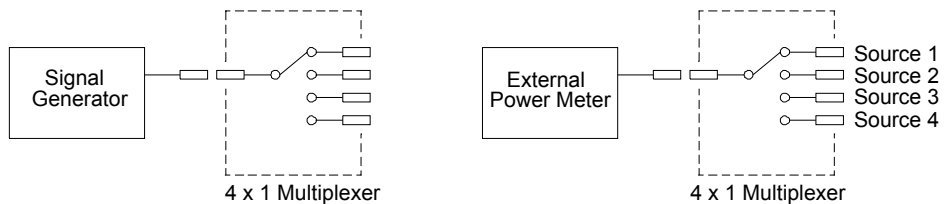

By using patch cables, you can expand RF multiplexers to provide additional test inputs or outputs. For example, you can combine two 4-to-1 multiplexers to create a 7-to-1 multiplexer as shown below.

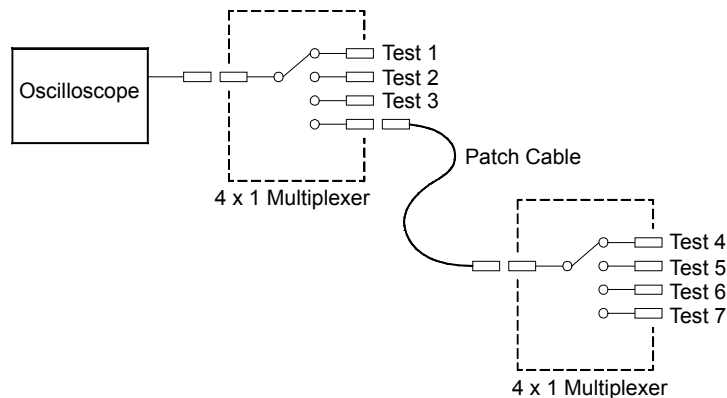

On the 34905A ( $50\Omega$ ) and 34906A ( $75\Omega$ ) RF multiplexers, you can close only one channel per bank at a time; closing one channel in a bank will open the previously closed channel. These modules respond *only* to the CLOSE command (OPEN does not apply). To open a channel, send the CLOSE command to another channel in the same bank.



## Sources of Error in RF Switching

Impedance mismatching can cause a variety of errors in an RF multiplexing system. These errors can cause distorted waveforms, overvoltage, or undervoltage conditions.

To minimize RF impedance mismatching:

- Use the correct cable and connector for the circuit impedance (50Ω or 75Ω). Note that it is difficult to visually differentiate a 50Ω connector from a 75Ω connector.
- Be sure that all leads and signal paths are properly terminated. Unterminated sections of line can appear as near shorts at RF frequencies. Note that the 34905A and 34906A *do not* automatically terminate open channels.

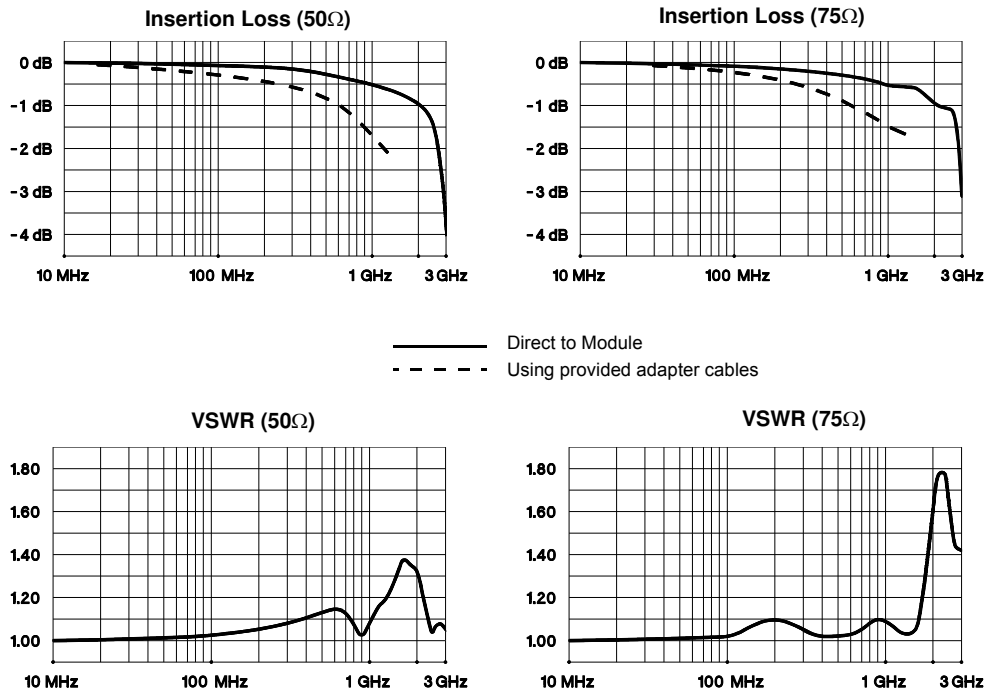

---

## Multifunction Module

### Digital Input

The 34907A module has two non-isolated 8-bit input/output ports which you can use for reading digital patterns.

- You can read the live status of the bits on the port or you can configure a scan to include a digital read.
- You can generate an alarm when a specific bit pattern or bit pattern change is detected on an input channel. The channels *do not* have to be part of the scan list to generate an alarm.
- The internal +5V pull-up circuitry allows you to use the digital input to detect contact closures like micro-switches or limit switches. An open input floats to +5V and is read as a “1”. An input shorted to ground is read as a “0”. An example of a contact closure detection channel is shown below.

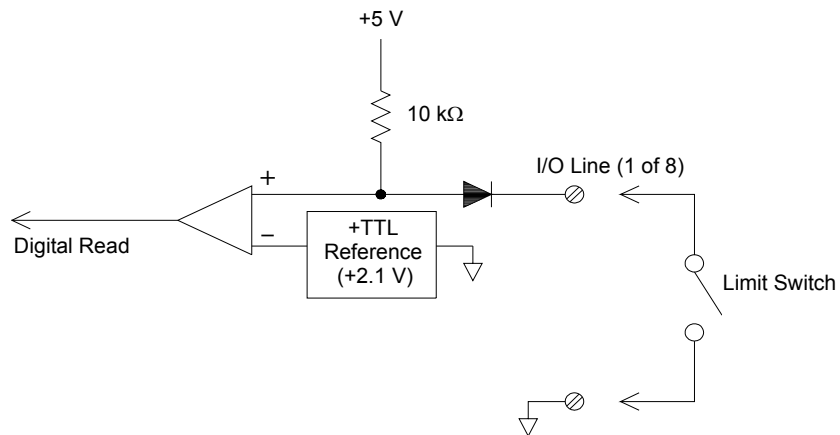

## Digital Output

The 34907A module has two non-isolated 8-bit input/output ports, which you can use for outputting digital patterns. You can combine the two ports to output a 16-bit word. A simplified diagram of a single output bit is shown below.

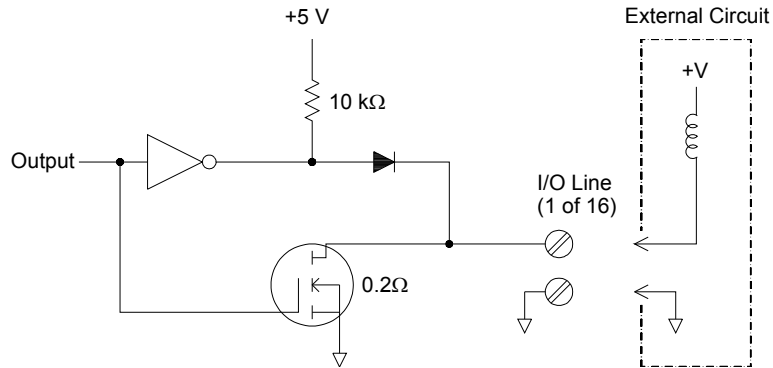

- Each output bit is capable of directly driving up to 10 TTL loads (less than 1 mA). The buffer for each port is used to drive a high output from the internal +5V supply through the diode. The drive is rated at +2.4V minimum at 1 mA.
- Each output bit is also an active sink, capable of sinking up to 400 mA from an external power supply. The FET is used to sink currents and has a nominal “on” resistance of 0.2Ω.
- For non-TTL logic you must provide an external pull-up. A description of the pull-up calculation is given on the following page.
- If used with an external power supply and pull-up, the external supply must be greater than +5 VDC and less than +42 VDC.

## Using an External Pull-Up

In general, an external pull-up is required only when you want to set the output “high” value greater than TTL levels. For example, to use a +12V external power supply, the value of the external pull-up resistor is calculated as follows:

$$V_{CC} = 12 \text{ VDC}$$

$$I_{\max} = I_{\text{out low}} \times \text{safety factor} = 1 \text{ mA} \times 0.5 + 0.5 \text{ mA}$$

$$R = \frac{V_{CC}}{I_{\max}} = \frac{12}{0.0005} = 24 \text{ k}\Omega$$

The value of the logic “high” level with the external 24 kΩ pull-up resistor is calculated as follows:

$$V_{\text{high}} = V_{CC} \times \frac{R_{\text{external}}}{R_{\text{external}} + R_{\text{external}}} = 12 \times \frac{24 \text{ k}\Omega}{24 \text{ k}\Omega + 10 \text{ k}\Omega} = 8.47 \text{ VDC}$$

## Driving External Switches

You can use two digital output channels to control an external switch. For example, you can drive the Agilent 876X series of microwave switches using an external power supply and two digital output channels. The state of the 2-to-1 multiplexer is changed by setting the appropriate output bit low (0).

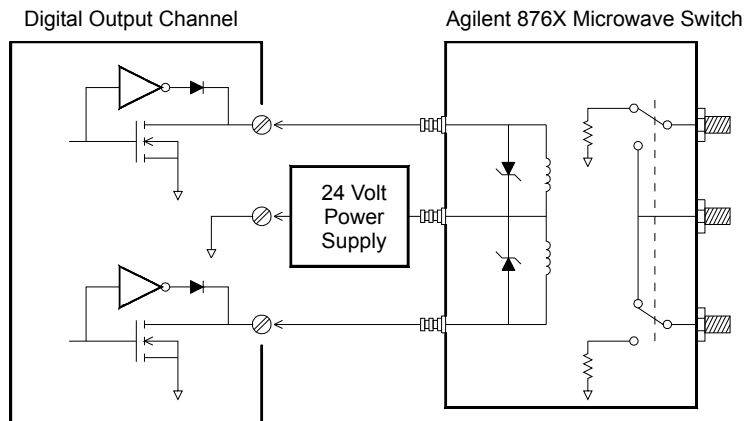

## Totalizer

The 34907A module has a 26-bit totalizer which can count pulses at a 100 kHz rate. You can manually read the totalizer count or you can configure a scan to read the count.

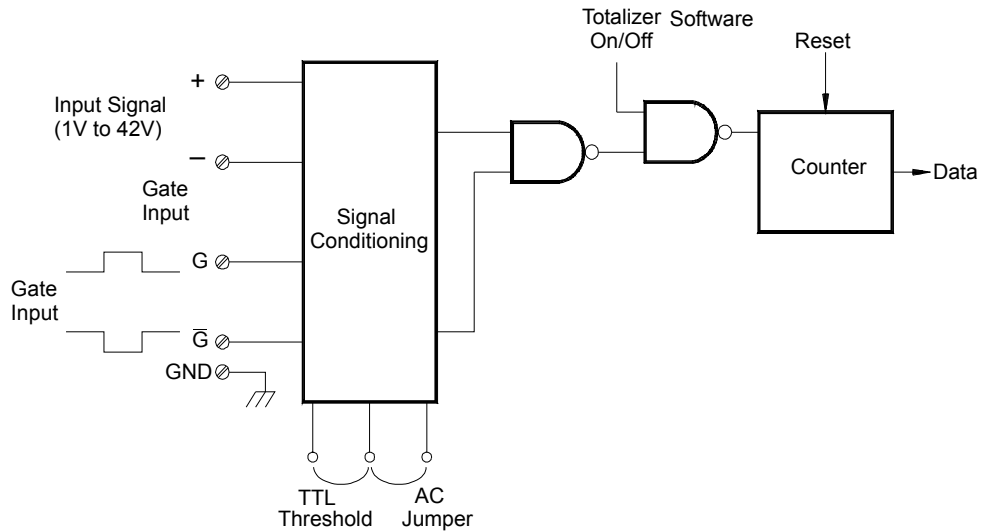

- You can configure the totalizer to count on the rising edge or falling edge of the input signal.
- Using the hardware jumper labeled “Totalize Threshold” on the module, you can control the threshold at which an edge is detected. Move the jumper to the “AC” position to detect changes through 0 volts. Move the jumper to the “TTL” position (factory setting) to detect changes through TTL threshold levels.

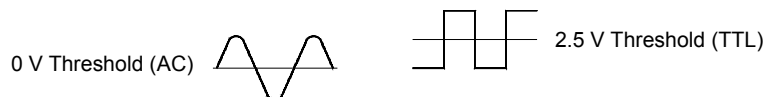

- The maximum count is 67,108,863 ( $2^{26} - 1$ ). The count rolls over to “0” after reaching the maximum allowed value.

- You can control when the totalizer actually records counts by providing a *gate signal* (G and  $\bar{G}$  terminals on the module). A TTL high signal applied to the “G” terminal enables counting and a low signal disables counting. A TTL low signal applied to the “ $\bar{G}$ ” terminal enables counting and a high signal disables counting. The totalizer only counts when both terminals are enabled. You can use either the G terminal, the  $\bar{G}$  terminal, or both. *When a gate is not connected, the gate terminal floats to the enabled state, effectively creating a “gate always” condition.*

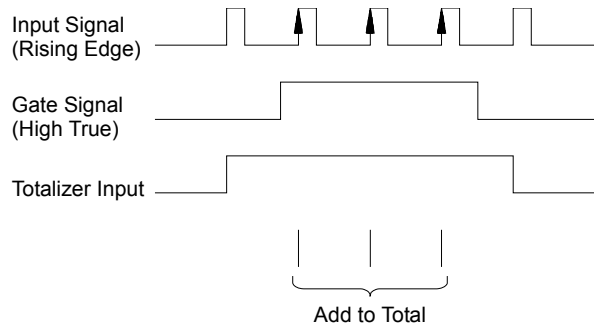

## Totalizer Errors

- Noise on the totalizer input can be a problem, especially on signals with a slow rise time. This noise can create a false indication of a threshold crossing. *For more information on cabling noise, see page 257.*
- Contact bounce on external switches can create false counts. All mechanical switches bounce when they open and close. Use an external capacitor to filter the contact bounce.

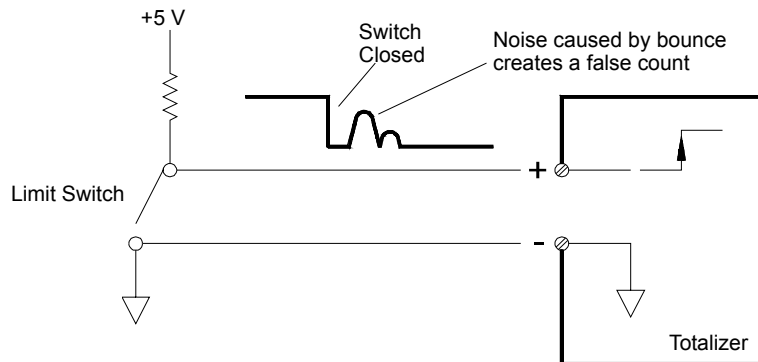

## Voltage (DAC) Output

The 34907A module has two analog outputs capable of outputting calibrated voltages between  $\pm 12$  volts with 16 bits of resolution. Each DAC (*Digital-to-Analog Converter*) channel can be used as a programmable voltage source for analog input to other devices.

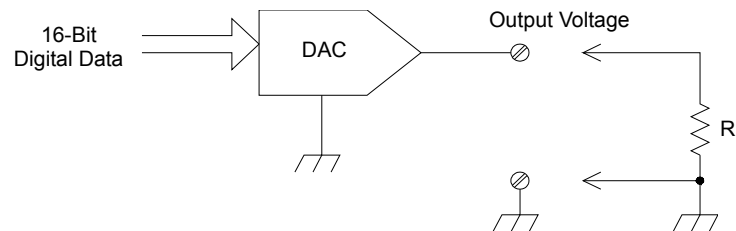

- You can set the output voltage to any value between +12 VDC and -12 VDC, in 1 mV steps. Each DAC is earth referenced; *it cannot float*.
- Each DAC channel is capable of supplying 10 mA maximum current.  
**Note:** You must limit the output current to 40 mA total for all three slots (six DAC channels).
- To maintain the rated output accuracy, the load ( $R_L$  in the diagram shown above) must be greater than 1 k $\Omega$ .

## DAC Errors

The output of a DAC varies with temperature. If possible, you should operate the instrument at a stable temperature and as close as possible to the calibration temperature of the DAC for greater accuracy.

The output of a DAC also exhibits two other types of errors: *differential error* and *integral error*.

- *Differential Error* refers to the smallest possible change in voltage. The DAC output is not linear, but is stepped as progressively larger (or smaller) voltages are programmed. The step size is 1 mV.
- *Integral Error* refers to the difference between the programmed voltage and the actual output voltage from the DAC. This error is included in the output specifications shown in chapter 8.

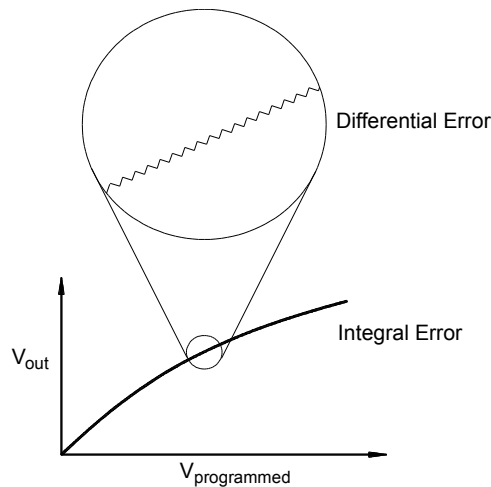



---

## Relay Life and Preventive Maintenance

The 34970A/34972A *Relay Maintenance System* automatically counts the cycles on each relay in the instrument and stores the total count in non-volatile memory on each switch module. Use this feature to track relay failures and predict system maintenance requirements. *For more information on using this feature, refer to “Relay Cycle Count” on page 169.*

Relays are electromechanical devices which are subject to wear-out failure modes. The life of a relay, or the number of actual operations before failure, is dependent upon how it is used – applied load, switching frequency, and environment.

You can use the graphs shown in this section to estimate relay lifetimes for your application. Additional background information is also provided to give you a better understanding of relay wear-out mechanisms. In general, relay lifetimes depend heavily upon the signals that are being switched and the types of measurements being performed.

- Switching typical signal levels will result in relay lifetimes from 1,000,000 to 10,000,000 operations.
- High-power switching (>25% rating) or high-voltage switching (>100V) applications will yield relay lifetimes from 100,000 to 1,000,000 operations.
- Low-voltage switching (<30V) and low-current switching (<10 mA) applications will yield relay lifetimes to 10,000,000 operations.
- RF switching applications seldom exhibit relay lifetimes exceeding 1,000,000 operations due to more stringent contact resistance requirements (typically less than 0.2Ω).

The following table shows the time required to reach the specified number of switch operations for several switching speeds.

Continuous Switching Speed	Switching Operations		
	100,000	1,000,000	10,000,000
1 / Hour	12 Years		
1 / Minute	10 Weeks	2 Years	
1 / Second	1 Day	12 Days	4 Months
10 / Second	3 Hours	1 Day	12 Days



## Relay Life

As a relay is used, the contacts begin to wear and the resistance of the closed contacts increases. The initial contact resistance of a relay is typically 50 m $\Omega$  (plus lead resistance). When the contact resistance exceeds 20 to 50 times its initial value, the contact resistance becomes very erratic and the relay should probably be replaced. For most applications, a relay with contact resistance greater than 1 $\Omega$  should be replaced. The graph below shows the typical contact resistance characteristics of the relays used on the 34970A/34972A switching modules.

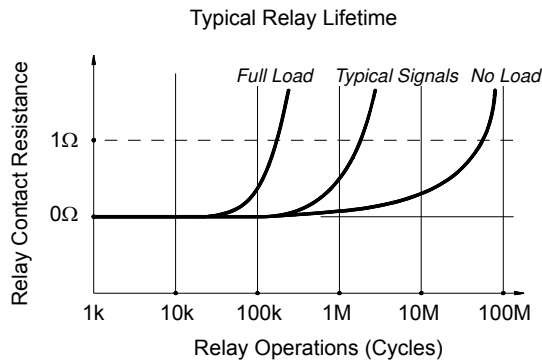

## Relay Load

For most applications, the load switched by the relay is the most important factor affecting relay life. As shown in the graph below, relay life is maximized by switching low power. As the power switched increases, relay life deteriorates.

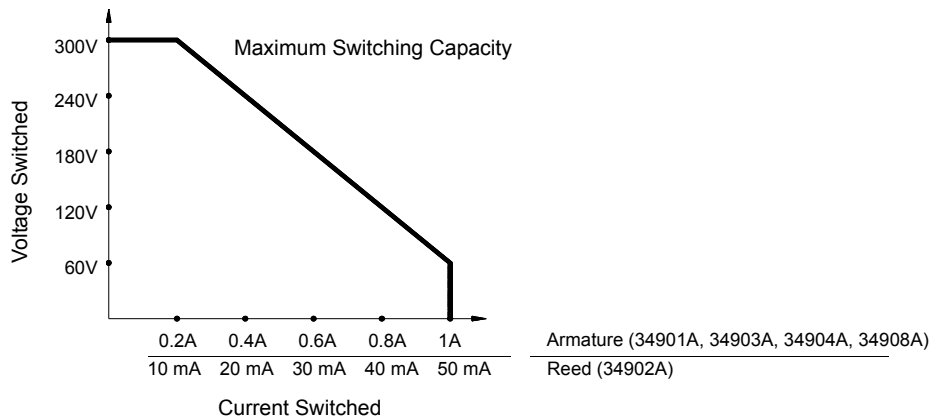

## Switching Frequency

Relay contacts heat up as they switch significant power. The heat is dissipated through the leads and the body of the relay. As you increase the switching frequency to near its maximum, heat cannot dissipate before the next cycle. The contact temperature rises and the life of the relay is reduced.

## Replacement Strategy

There are essentially two strategies that you can use for preventive maintenance of the relays on the switching modules. The strategy that you choose depends upon your application, the consequences of a relay failure in your system, and the number of relay cycles during a measurement session.

The first strategy is to replace each relay as needed after it fails or becomes erratic. This is suitable if you are switching higher loads on only a few relays on the module. The disadvantage of this strategy is the inconvenience of continually replacing relays as they near the end of their life at different times.

The second strategy is to replace all relays on the module or simply purchase a new module as the relays near the end of their life. This strategy is best suited for those applications where all relays on the module are switching similar loads. The failure of several relays over a relatively short period of time may indicate impending failures on other relays switching similar loads. This strategy decreases the risk of failure during actual use at the expense of replacing some relays that may have useful life remaining.

**Note:** In both cases described above, you can use the 34970A/34972A *Relay Maintenance System* to track and even predict relay failures.



- DC, Resistance, and Temperature Accuracy Specifications, *on page 326*
- DC Measurement and Operating Characteristics, *on page 327*
- AC Accuracy Specifications, *on page 328*
- AC Measurement and Operating Characteristics, *on page 329*
- System Characteristics, *on page 330*
- System Speed Specifications [1], *on page 331*
- Module Specifications- 34901A, 34902A, 34908A, 34903A, 34904A, *on page 333*
- Module Specifications - 34905A, 34906A, *on page 334*
- Typical AC Performance Graphs - 34905A, 34906A, *on page 335*
- Module Specifications - 34907A, *on page 336*
- Product and Module Dimensions, *on page 337*
- To Calculate Total Measurement Error, *on page 338*
- Interpreting Internal DMM Specifications, *on page 340*
- Configuring for Highest Accuracy Measurements, *on page 343*

---

## Specifications

## ■ DC, Resistance, and Temperature Accuracy Specifications

± (% of reading + % of range) <sup>[1]</sup>

*Includes measurement error, switching error, and transducer conversion error*

Function	Range <sup>[3]</sup>	Test Current or Burden Voltage	24 Hour <sup>[2]</sup> 23 °C ± 1 °C	90 Day 23 °C ± 5 °C	1 Year 23 °C ± 5 °C	Temperature Coefficient /°C 0 °C - 18 °C 28 °C - 55 °C
<b>DC Voltage</b>	100.0000 mV 1.000000 V 10.00000 V 100.0000 V 300.000 V		0.0030 + 0.0035 0.0020 + 0.0006 0.0015 + 0.0004 0.0020 + 0.0006 0.0020 + 0.0020	0.0040 + 0.0040 0.0030 + 0.0007 0.0020 + 0.0005 0.0035 + 0.0006 0.0035 + 0.0030	0.0050 + 0.0040 0.0040 + 0.0007 0.0035 + 0.0005 0.0045 + 0.0006 0.0045 + 0.0030	0.0005 + 0.0005 0.0005 + 0.0001 0.0005 + 0.0001 0.0005 + 0.0001 0.0005 + 0.0003
<b>Resistance<sup>[4]</sup></b>	100.0000 Ω 1.000000 kΩ 10.00000 kΩ 100.0000 kΩ 1.000000 MΩ 10.00000 MΩ 100.0000 MΩ	1 mA current source 1 mA 100 μA 10 μA 5 μA 500 nA 500nA    10 MΩ	0.0030 + 0.0035 0.0020 + 0.0006 0.0020 + 0.0005 0.0020 + 0.0005 0.002 + 0.001 0.015 + 0.001 0.300 + 0.010	0.008 + 0.004 0.008 + 0.001 0.008 + 0.001 0.008 + 0.001 0.008 + 0.001 0.020 + 0.001 0.800 + 0.010	0.010 + 0.004 0.010 + 0.001 0.010 + 0.001 0.010 + 0.001 0.010 + 0.001 0.040 + 0.001 0.800 + 0.010	0.0006 + 0.0005 0.0006 + 0.0001 0.0006 + 0.0001 0.0006 + 0.0001 0.0010 + 0.0002 0.0030 + 0.0004 0.1500 + 0.0002
<b>DC Current</b> <i>34901A Only</i>	10.00000 mA 100.0000 mA 1.000000 A	< 0.1 V burden <0.6 V <2 V	0.005 + 0.010 0.010 + 0.004 0.050 + 0.006	0.030 + 0.020 0.030 + 0.005 0.080 + 0.010	0.050 + 0.020 0.050 + 0.005 0.100 + 0.010	0.002 + 0.0020 0.002 + 0.0005 0.005 + 0.0010
Temperature	Type	1-Year Best Range Accuracy <sup>[5]</sup>		Extended Range Accuracy <sup>[5]</sup>		Temperature Coefficient /°C
<b>Thermocouple<sup>[6]</sup></b>	B E J K N R S T	1100°C to 1820°C -150°C to 1000°C <b>-150°C to 1200°C</b> -100°C to 1200°C -100°C to 1300°C 300°C to 1760°C 400°C to 1760°C -100°C to 400°C	1.2°C 1.0°C <b>1.0°C</b> 1.0°C 1.0°C 1.2°C 1.2°C 1.0°C	400°C to 1100°C -200°C to -150°C <b>-210°C to -150°C</b> -200°C to -100°C -200°C to -100°C -50°C to 300°C -50°C to 400°C -200°C to -100°C	1.8°C 1.5°C <b>1.2°C</b> 1.5°C 1.5°C 1.8°C 1.8°C 1.5°C	0.03°C 0.03°C <b>0.03°C</b> 0.03°C 0.03°C 0.03°C 0.03°C 0.03°C
<b>RTD</b>	R <sub>0</sub> from 49Ω to 2.1 kΩ	-200°C to 600°C	0.06°C			0.003°C
<b>Thermistor</b>	2.2 k, 5 k, 10 k	-80°C to 150°C	0.08°C			0.002°C

[1] Specifications are for 1 hour warm up and 6½ digits, slow AC filter.

[2] Relative to calibration standards.

[3] 20% over range on all ranges except 300 VDC and 1 Adc ranges.

[4] Specifications are for 4-wire ohms function or 2-wire ohms using Scaling to remove the offset.

Without Scaling, add 4Ω additional error in 2-wire ohms function.

[5] 1 year accuracy. For total measurement accuracy, add temperature probe error.

[6] Thermocouple specifications are not guaranteed when 34907A module is present.

## ■ DC Measurement and Operating Characteristics

<b>DC Measurement Characteristics</b> <sup>[1]</sup>	
<b>DC Voltage</b>	
Measurement Method:	Continuously Integrating Multi-slope III A/D Converter
A/D Linearity:	0.0002% of reading + 0.0001% of range
Input Resistance:	Selectable 10 M $\Omega$ or > 10 G $\Omega$
100 mV, 1V, 10 V ranges	10 M $\Omega$ $\pm$ 1%
100 V, 300 V ranges	< 30 pA at 25 °C
Input Bias Current:	< 30 pA at 25 °C
Input Protection:	300 V on all ranges
<b>Resistance</b>	
Measurement Method:	Selectable 4-wire or 2-wire Ohms Current source reference to LO input
Offset compensation:	Selectable on 100 $\Omega$ , 1k $\Omega$ , 10k $\Omega$ ranges
Max. Lead Resistance:	10% of range per lead for 100 $\Omega$ and 1 k $\Omega$ ranges. 1 k $\Omega$ on all other ranges
Input Protection:	300 V on all ranges
<b>DC Current</b>	
Shunt Resistance:	5 $\Omega$ for 10 mA, 100 mA; 0.1 $\Omega$ for 1A.
Input Protection:	1.5A 250 V fuse on 34901A module
<b>Thermocouple</b>	
Conversion:	ITS-90 software compensation
Reference Junction Type:	Internal, Fixed, or External
Open T/C Check:	Selectable per channel. Open > 5 k $\Omega$
<b>RTD</b>	$\alpha$ - 0.00385 (DIN/IEC 751) using ITS-90 software compensation or $\alpha$ = 0.00391 using IPTS-68 software compensation.
<b>Thermistor</b>	44004, 44007, 44006 series
<b>Measurement Noise Rejection 60 Hz (50 Hz)</b> <sup>[2]</sup>	
DC CMRR:	140 dB
<b>Integration Time</b> <b>Normal Mode Rejection</b> <sup>[3]</sup>	
200 PLC / 3.33s (4s)	110 dB <sup>[4]</sup>
100 PLC / 1.67s (2s)	105 dB <sup>[4]</sup>
20 PLC / 333 ms (400 ms)	100 dB <sup>[4]</sup>
10 PLC / 167 ms (200 ms)	95 dB <sup>[4]</sup>
2 PLC / 33.3 ms (40 ms)	90 dB
1 PLC / 16.7 ms (20 ms)	60 dB
< 1PLC	0 dB

Chapter 8 Specifications  
**AC Accuracy Specifications**

■ **AC Accuracy Specifications**

± (% of reading + % of range)<sup>[1]</sup>  
*Includes measurement error, switching error, and transducer conversion error*

Function	Range <sup>[3]</sup>	Frequency	24 Hour <sup>[2]</sup> 23 °C ± 1 °C	90 Day 23 °C ± 5 °C	1 Year 23 °C ± 5 °C	Temperature Coefficient /°C 0 °C - 18 °C 28 °C - 55 °C
<b>True RMS AC Voltage</b> <sup>[4]</sup>	100.0000 mV to 100 V	3 Hz - 5 Hz 5 Hz - 10 Hz 10 Hz - 20 kHz 20 kHz - 50 kHz 50 kHz - 100 kHz 100 kHz - 300 kHz <sup>[5]</sup>	1.00 + 0.03 0.35 + 0.03 0.04 + 0.03 0.10 + 0.05 0.55 + 0.08 4.00 + 0.50	1.00 + 0.04 0.35 + 0.04 0.05 + 0.04 0.11 + 0.05 0.60 + 0.08 4.00 + 0.50	1.00 + 0.04 0.35 + 0.04 0.06 + 0.04 0.12 + 0.05 0.60 + 0.08 4.00 + 0.50	0.100 + 0.004 0.035 + 0.004 0.005 + 0.004 0.011 + 0.005 0.060 + 0.008 0.20 + 0.02
	300.0000 V	3 Hz - 5 Hz 5 Hz - 10 Hz 10 Hz - 20 kHz 20 kHz - 50 kHz 50 kHz - 100 kHz 100 kHz - 300 kHz <sup>[5]</sup>	1.00 + 0.05 0.35 + 0.05 0.04 + 0.05 0.10 + 0.10 0.55 + 0.20 4.00 + 1.25	1.00 + 0.08 0.35 + 0.08 0.05 + 0.08 0.11 + 0.12 0.60 + 0.20 4.00 + 1.25	1.00 + 0.08 0.35 + 0.08 0.06 + 0.08 0.12 + 0.12 0.60 + 0.20 4.00 + 1.25	0.100 + 0.008 0.035 + 0.008 0.005 + 0.008 0.011 + 0.012 0.060 + 0.020 0.20 + 0.05
<b>Frequency and Period</b> <sup>[6]</sup>	100 mV to 300 V	3 Hz - 5 Hz 5 Hz - 10 Hz 10 Hz - 40 Hz 40 Hz - 300 kHz	0.10 0.05 0.03 0.006	0.10 0.05 0.03 0.01	0.10 0.05 0.03 0.01	0.005 0.005 0.001 0.001
<b>True RMS AC Current</b> <i>34901A Only</i>	10.00000 mA <sup>[4]</sup> and 1.000000 A <sup>[4]</sup>	3 Hz - 5 Hz 5 Hz - 10 Hz 10 Hz - 5 kHz	1.00 + 0.04 0.30 + 0.04 0.10 + 0.04	1.00 + 0.04 0.30 + 0.04 0.10 + 0.04	1.00 + 0.04 0.30 + 0.04 0.10 + 0.04	0.100 + 0.006 0.035 + 0.006 0.015 + 0.006
	100.0000 mA <sup>[7]</sup>	3 Hz - 5 Hz 5 Hz - 10 Hz 10 Hz - 5 kHz	1.00 + 0.5 0.30 + 0.5 0.10 + 0.5	1.00 + 0.5 0.30 + 0.5 0.10 + 0.5	1.00 + 0.5 0.30 + 0.5 0.10 + 0.5	0.100 + 0.06 0.035 + 0.06 0.015 + 0.06

Additional Low Frequency Error for ACV, ACI (% of reading)				Additional Error for Frequency, Period (% of reading)			
Frequency	AC Filter Slow	AC filter Medium	AC Filter Fast	Frequency	6½ Digits	5½ Digits	4½ Digits
10 Hz - 20 Hz	0	0.74	--	3 Hz - 5 Hz	0	0.12	0.12
20 Hz - 40 Hz	0	0.22	--	5 Hz - 10 Hz	0	0.17	0.17
40 Hz - 100 Hz	0	0.06	0.73	10 Hz - 40 Hz	0	0.2	0.2
100 Hz - 200 Hz	0	0.01	0.22	40 Hz - 100 Hz	0	0.06	0.21
200 Hz - 1 kHz	0	0	0.18	100 Hz - 300 Hz	0	0.03	0.21
> 1 kHz	0	0	0	300 Hz - 1 kHz	0	0.01	0.07
				>1 kHz	0	0	0.02

[1] Specifications are for 1 hour warm up and 6½ digits, Slow AC filter

[2] Relative to calibration standards

[3] 20% over range on all ranges except 300 VAC and 1 A ac ranges and AC current ranges.

[4] For sinewave input >5% of range. For inputs from 1% to 5% of range and <50 kHz, add 0.1% of range additional error.

[5] Typically 30% of reading error at 1 MHz, limited to 1x10<sup>8</sup> V Hz

[6] Input > 100 mV. For 10 mV to 100 mV inputs, multiply % of reading error x 10.

[7] Specified only for inputs > 10 mA



## AC Measurement and Operating Characteristics

### AC Measurement Characteristics <sup>[1]</sup>

#### True RMS AC Voltage

Measurement Method:	AC-coupled True RMS -measures the AC component of input with up to 300 VDC of bias on any range
Crest Factor:	Maximum 5:1 at Full Scale
Additional Crest Factor Errors (non-sinewave): <sup>[2]</sup>	Crest Factor 1-2: 0.05% of reading Crest Factor 2-3: 0.15% of reading Crest Factor 3-4: 0.30% of reading Crest Factor 4-5: 0.40% of reading
AC Filter Bandwidth:	
Slow	3 Hz - 300 kHz
Medium	20 Hz - 300 kHz
Fast	200 Hz - 300 kHz
Input Impedance:	1 M $\Omega$ $\pm$ 2%, in parallel with 150 pF
Input Protection:	300 Vrms on all ranges

#### Frequency and Period

Measurement Method:	Reciprocal counting technique
Voltage Ranges:	Same as AC Voltage function
Gate Time:	1s, 100 ms, or 10 ms
Measurement Timeout:	Selectable 3 Hz, 20 Hz, 200 Hz LF limit

#### True RMS AC Current

Measurement Method:	Direct coupled to the fuse and shunt. AC-coupled True RMS measurement (measures the AC component only)
Shunt Resistance:	5 $\Omega$ for 10 mA; 0.1 $\Omega$ for 100 mA, 1A
Input Protection:	1.5A 250 V fuse on 34901A module

#### Measurement Noise Rejection <sup>[3]</sup>

AC CMRR:	70 dB
----------	-------

#### Measurement Considerations (Frequency and Period)

All frequency counters are susceptible to error when measuring low-voltage, low-frequency signals. Shielding inputs from external noise pickup is critical for minimizing measurement errors.

## Chapter 8 Specifications

### System Characteristics

## System Characteristics

System Characteristics	
<b>Scan Triggering</b>	
Scan Count:	1 to 50,000 or continuous
Scan Interval:	0 to 99 hours; 1 ms step size
Channel Delay:	0 to 60 seconds/channel; 1 ms step size
External Trig Delay:	< 300 $\mu$ s; With Monitor On, < 200 ms
External Trig Jitter:	< 2 ms
<b>Alarms</b>	
Alarm Outputs:	4 TTL compatible. Selectable TTL logic HI or LO on Fail
Latency:	5 ms (typical)
<b>Memory</b>	
	Battery Backed, 34970A - 4 year typical life <sup>[1]</sup> 34972A - User-replaceable battery, recommended replacement during yearly calibration.
Readings:	50,000 internal readings with timestamp, readable during scan.
Time Stamp Resolution:	
Relative	1 ms
Absolute	1 s
States:	5 instrument states
Alarm Queue:	Up to 20 events
USB Drive:	FAT or FAT32 format
<b>General Specifications</b>	
Power Supply:	100 V / 120 V / 220 V/240 V $\pm$ 10%
Power Line Frequency:	45 Hz to 60 Hz automatically sensed
Power Consumption:	(12 W) 25 VA peak
Operating Environment:	Full accuracy for 0 °C to 55 °C Full accuracy to 80% R.H. at 40 °C
Storage Environment:	-40 °C to 70 °C <sup>[1]</sup>
Weight (Mainframe):	Net: 3.6 kg (8.0 lbs)
Safety:	Conforms to CSA, US-1244, IEC 1010 CAT I
RFI and ESD:	CISPR 11, IEC 801/2/3/4
Warranty:	1 year

[1] Storage at temperatures above 40 °C will decrease battery life.

*This ISM device complies with Canadian ICES-001.*

*Cet appareil ISM est conforme à norme NMB-001 du Canada.*



## ■ System Speed Specifications [1]

Single Channel Reading Rates to I/O or internal memory	34970A		34972A
	into Memory	to GPIB or RS232	to LAN, USB or Memory
	readings/sec	readings/sec	readings/sec
Single Channel ASCII dcV readings	500	440	500
Single Channel while changing scale (eg MEAS dcV 10 / MEAS dcV 1)	25	25	25
Single Channel while changing function (eg MEAS dcV / MEAS Ohms)	12	12	12
Scanning Measurement Rates to I/O or internal memory	34970A		34972A
	into Memory	to GPIB or RS232	to LAN, USB or Memory
	ch/sec	ch/sec	ch/sec
<b>Scanning DCV or Ohms channels</b>			
34901A/34908A	60	60	60
34902A	250	210	240
34902A into and out of memory (using INIT, FETCh)	--	180	240
34902A with timestamp (using MEAS)	--	150	240
34902A with scaling and alarms	220	190	220
34902A DCV and ohms on alternate channels	80	80	80
<b>Scanning ACV channels [2]</b>			
34901A/34908A	50	50	50
34902A	100	90	100
<b>Scanning Temperature - Thermistor or T/C channels</b>			
34901A/34908A	50	50	50
34902A	150	150	150
<b>Scanning Digital In/Totalizer channels</b>			
34907A Digital Input	275	250	275
34907A Totalizer	240	210	240

[1] Speeds are for 4½ digits, delay 0, display off, autozero off, unless otherwise noted. Use MEAS command for best I/O performance. RS232 at 115Kbaud.

[2] Maximum, with default delays defeated.

Chapter 8 Specifications  
**System Speed Specifications**

## System Speed Specifications

Data out of memory [3][4]	34970A		34972A	
	over GPIB	over RS232	over USB	over LAN or memory
(FETCh of 50K readings)	readings/sec	readings/sec	readings/sec	readings/sec
Readings	800	600	55K	120K
Readings with timestamp	450	320	35K	60K
Readings with all format options ON.	310	230	25K	50K

[3] Assumes relative time format (time since start of scan)

[4] Typical rates assuming lightly loaded PC and limited other traffic on I/Os. LAN rates assume use of socket connection; VXI11 will be less.

[5] For fixed function and range, readings to memory, scaling/alarms/autozero off

## Module Specifications

34901A, 34902A, 34908A, 34903A, 34904A

General	Multiplexer			Actuator	Matrix
	34901A	34902A	34908A	34903A	34904A
Number of Channels	20+2	16	40	20	4x8
	2/4 wire	2/4 wire	1 wire	SPDT	2 wire
Connects to Internal DMM	Yes	Yes	Yes	No	No
Scanning Speed <sup>[1]</sup>	60 ch/s	250 ch/s	60 ch/s		
Open/Close Speed	120/s	120/s	70/s	120/s	120/s
<b>Maximum Input</b>					
Voltage (dc, AC rms)	300 V	300 V	300 V	300 V	300 V
Current (dc, AC rms)	1 A	50 mA	1 A	1 A	1 A
Power (W, VA)	50 W	2 W	50W	50W	50W
Isolation (ch-ch, ch-earth)      dc, AC rms	300 V	300 V	300 V	300 V	300 V
<b>DC Characteristics</b>					
Offset Voltage <sup>[2]</sup>	< 3 $\mu$ V	<6 $\mu$ V	< 3 $\mu$ V	< 3 $\mu$ V	< 3 $\mu$ V
Initial Closed Channel R <sup>[2]</sup>	< 1 $\Omega$	< 1 $\Omega$	< 1 $\Omega$	< 0.2 $\Omega$	< 1 $\Omega$
Isolation (ch-ch, ch-earth)	> 10 G $\Omega$	> 10 G $\Omega$	> 10 G $\Omega$	> 10 G $\Omega$	> 10 G $\Omega$
<b>AC Characteristics</b>					
Bandwidth	10 MHz	10 MHz	10 MHz	10 MHz	10 MHz
Ch-Ch Cross Talk (dB) <sup>[3]</sup> 10 MHz	-45	-45	-18 <sup>[4]</sup>	-45	-33
Capacitance      HI to LO	< 50 pF	< 50 pF	< 50 pF	< 10 pF	< 50 pF
Capacitance      LO to Earth	< 80 pF	< 80 pF	< 80 pF	< 80 pF	< 80 pF
Volt-Hertz Limit	10 <sup>8</sup>	10 <sup>8</sup>	10 <sup>8</sup>	10 <sup>8</sup>	10 <sup>8</sup>
<b>Other</b>					
T/C cold Junction Accuracy <sup>[2] [5]</sup> (typical)	0.8 °C	0.8 °C	0.8 °C <sup>[7]</sup>		
Switch Life      No Load (typical)	100M	100M	100M	100M	100M
Switch Life      Rated Load (typical) <sup>[6]</sup>	100k	100k	100k	100k	100k
Temperature      Operating	All Modules: 0 °C to 55 °C				
Temperature      Storage	All Modules: -20 °C to 70 °C				
Humidity (non-condensing)	All Modules: 40 °C / 80% R.H.				

[1] See scanning rate specifications for measurement conditions and rates on each instrument.

[2] Errors included in the DMM measurement accuracy specifications

[3] 50 $\Omega$  source, 50 $\Omega$  load

[4] Isolation within channel 1 to 20 or 21 to 40 banks is -40 dB

[5] Thermocouple specifications not guaranteed when 34907A module is present

[6] Applies to resistive loads only

[7] Thermocouple measurements not recommended with 34908A module due to common LO configuration.

Chapter 8 Specifications  
**Module Specifications**

■ **Module Specifications**  
*34905A, 34906A*

	RF Multiplexer	
General	34905A	34906A
Number of Channels	Dual 1x4 50Ω	Dual 1x4 75Ω
Open/Close Speed	60/s	
Maximum Input		
Voltage (dc, AC rms)	42 V	
Current (dc, AC rms)	0.7 A	
Power (W, VA)	20 W	
DC Characteristics		
Offset Voltage <sup>[1]</sup>	< 6 μV	
Initial Closed Channel R <sup>[1]</sup>	< 0.5 Ω	
Isolation (ch-ch, ch-earth)	> 1 GΩ	
Other		
Switch Life	No Load (typical)	5M
Switch Life	Rated Load (typical) <sup>[2]</sup>	100k
Temperature	Operating	0 °C to 55 °C
Temperature	Storage	-20 °C to 70 °C
Humidity (non-condensing)	40 °C/ 80% R.H.	

## Typical AC Performance Graphs

34905A, 34906A

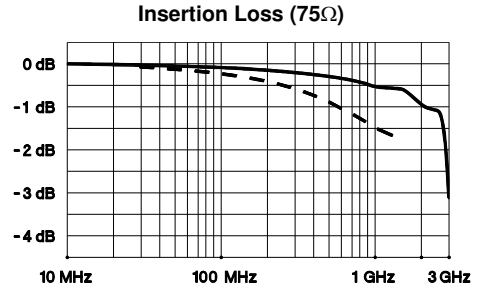
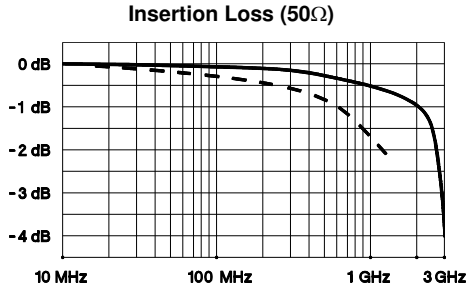

— Direct to Module  
- - - Using provided adapter cables

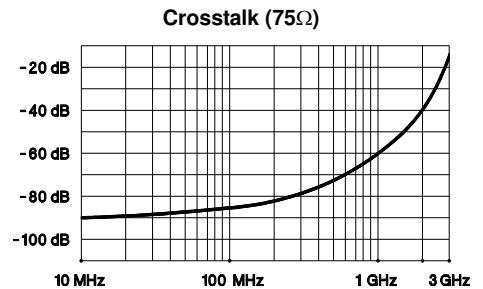
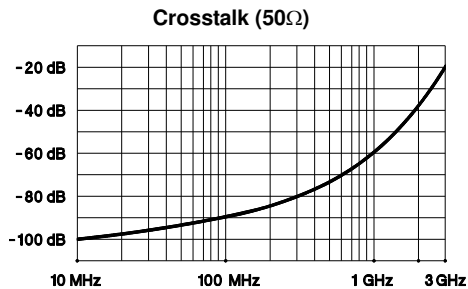
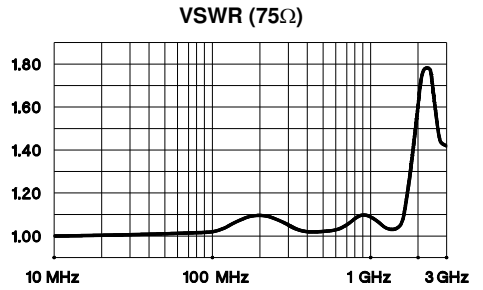
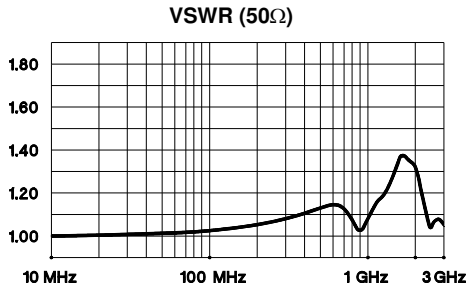

Chapter 8 Specifications  
**Module Specifications**

■ **Module Specifications**  
*34907A*

<b>Digital Input/Output</b>	
Port 1, 2:	8 Bit, input or output, non-isolated
Vin(L):	< 0.8V (TTL)
Vin (H):	> 2.0V (TTL)
Vout(L):	< 0.8V @ Iout = -400 mA
Vout(H)	> 2.4V @ Iout = 1 mA
Vin(H) Max:	<42V with external open drain pull-up
Alarming:	Maskable pattern match or state change
Speed	4 ms (max) alarm sampling
Latency	5 ms (typical) to 34970A/34972A alarm output
Read/Write Speed:	95/s

<b>Totalize Input</b>	
Maximum Count:	$2^{26} - 1$ (67,108,863)
Totalize Input:	100 kHz (max), rising or falling edge, programmable
Signal Level:	1 Vp-p (min) 42 Vpk (max)
Threshold:	0V or TTL, jumper selectable
Gate Input:	TTL-HI, TTL-LO, or none
County Reset:	Manual or Read+Reset
Read Speed:	85/s

<b>Analog Voltage (DAC) Output</b>	
DAC 1, 2:	$\pm 12V$ , non-isolated (earth referenced)
Resolution:	1 mV
Iout:	10 mA max <sup>[1]</sup>
Settling Time:	1 ms to 0.01% of output
Accuracy:	$\pm$ (% of output + mV)
1 year $\pm 5$ °C	0.25% + 20 mV
Temp Coefficient:	$\pm(0.015\% + 1 \text{ mV}) / \text{°C}$

[1] Limited to 40 mA total for all three slots (six DAC channels)



■ **Product and Module Dimensions**

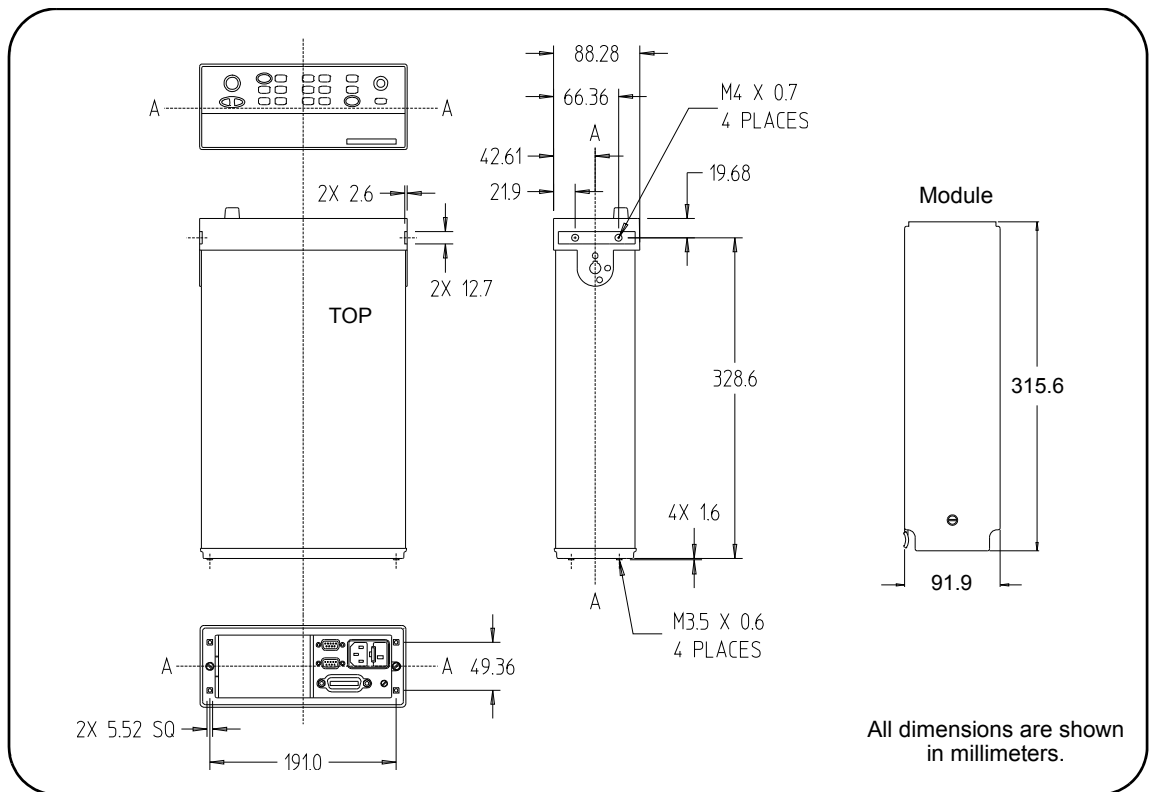
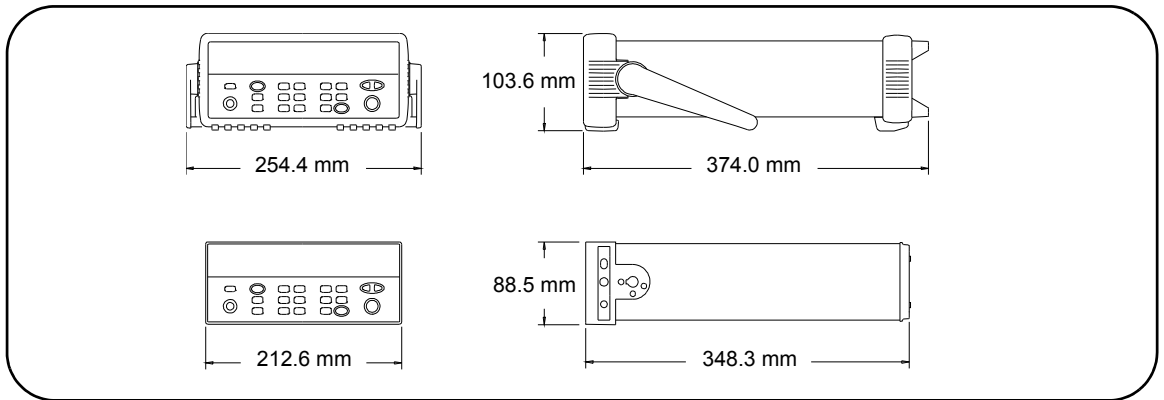

---

## To Calculate Total Measurement Error

Each specification includes correction factors which account for errors present due to operational limitations of the internal DMM. This section explains these errors and shows how to apply them to your measurements. Refer to “*Interpreting Internal DMM Specifications*,” starting on page 340, to get a better understanding of the terminology used and to help you interpret the internal DMM’s specifications.

The internal DMM’s accuracy specifications are expressed in the form: (*% of reading + % of range*). In addition to the reading error and range error, you may need to add additional errors for certain operating conditions. Check the list below to make sure you include all measurement errors for a given function. Also, make sure you apply the conditions as described in the footnotes on the specification pages.

- If you are operating the internal DMM outside the  $23\text{ }^{\circ}\text{C} \pm 5\text{ }^{\circ}\text{C}$  temperature range specified, apply an additional *temperature coefficient error*.
- For DC voltage, DC current, and resistance measurements, you may need to apply an additional *reading speed error*.
- For AC voltage and AC current measurements, you may need to apply an additional *low frequency error or crest factor error*.

**Understanding the “% of reading” Error** The *reading error* compensates for inaccuracies that result from the function and range you select, as well as the input signal level. The reading error varies according to the input level on the selected range. This error is expressed in percent of reading. The following table shows the reading error applied to the internal DMM’s 24-hour DC voltage specification. .

Range	Input Level	Reading Error (% of reading)	Reading Error Voltage
10 VDC	10 VDC	0.0015	$\leq 150\text{ }\mu\text{V}$
10 VDC	1 VDC	0.0015	$\leq 15\text{ }\mu\text{V}$
10 VDC	0.1 VDC	0.0015	$\leq 1.5\text{ }\mu\text{V}$

**Understanding the “ % of range ” Error** The *range error* compensates for inaccuracies that result from the function and range you select. The range error contributes a constant error, expressed as a percent of range, *independent* of the input signal level. The following table shows the range error applied to the DMM’s 24-hour DC voltage specification.

Range	Input Level	Reading Error (% of reading)	Range Error Voltage
10 VDC	10 VDC	0.0004	≤40 μV
10 VDC	1 VDC	0.0004	≤40 μV
10 VDC	0.1 VDC	0.0004	≤40 μV

**Total Measurement Error** To compute the total measurement error, add the reading error and range error. You can then convert the total measurement error to a “percent of input” error or a “ppm (part-per-million) of input” error as shown below.

$$\% \text{ of input error} = \frac{\text{Total Measurement Error}}{\text{Input Signal Level}} \times 100$$

$$\text{ppm of input error} = \frac{\text{Total Measurement Error}}{\text{Input Signal Level}} \times 1,000,000$$

**Example: Computing Total Measurement Error**

Assume that a 5 VDC signal is input to the DMM on the 10 VDC range. Compute the total measurement error using the 90-day accuracy specification of ±(0.0020% of reading + 0.0005% of range).

$$\begin{aligned} \text{Reading Error} &= 0.0020\% \times 5 \text{ VDC} &= 100 \mu\text{V} \\ \text{Range Error} &= 0.0005\% \times 10 \text{ VDC} &= 50 \mu\text{V} \\ \text{Total Error} &= 100 \mu\text{V} + 50 \mu\text{V} &= \pm 150 \mu\text{V} \\ & &= \pm 0.0030\% \text{ of } 5 \text{ VDC} \\ & &= \pm 30 \text{ ppm of } 5 \text{ VDC} \end{aligned}$$

## Interpreting Internal DMM Specifications

This section is provided to give you a better understanding of the terminology used and will help you interpret the internal DMM's specifications.

### Number of Digits and Overrange

The “number of digits” specification is the most fundamental, and sometimes, the most confusing characteristic of a multimeter. The number of digits is equal to the maximum number of “9’s” the multimeter can measure or display. This indicates the number of *full digits*. Most multimeters have the ability to overrange and add a partial or “½” digit.

For example, the internal DMM can measure 9.99999 VDC on the 10 V range. This represents six full digits of resolution. The internal DMM can also overrange on the 10 V range and measure up to a maximum of 12.00000 VDC. This corresponds to a 6½-digit measurement with 20% overrange capability.

### Sensitivity

Sensitivity is the minimum level that the internal DMM can detect for a given measurement. Sensitivity defines the ability of the internal DMM to respond to small changes in the input level. For example, suppose you are monitoring a 1 mVDC signal and you want to adjust the level to within  $\pm 1 \mu\text{V}$ . To be able to respond to an adjustment this small, this measurement would require a multimeter with a sensitivity of at least  $1 \mu\text{V}$ . You could use a 6½-digit multimeter *if* it has a 1 VDC or smaller range. You could also use a 4½-digit multimeter with a 10 mVDC range.

For AC voltage and AC current measurements, note that the smallest value that can be measured is different from the sensitivity. For the internal DMM, these functions are specified to measure down to 1% of the selected range. For example, the internal DMM can measure down to 1 mV on the 100 mV range.

## Resolution

Resolution is the numeric ratio of the maximum displayed value divided by the minimum displayed value on a selected range. Resolution is often expressed in percent, parts-per-million (ppm), counts, or bits. For example, a 6½-digit multimeter with 20% overrange capability can display a measurement with up to 1,200,000 counts of resolution. This corresponds to about 0.0001% (1 ppm) of full scale, or 21 bits including the sign bit. All four specifications are equivalent.

## Accuracy

Accuracy is a measure of the “exactness” to which the internal DMM’s measurement uncertainty can be determined *relative* to the calibration reference used. Absolute accuracy includes the internal DMM’s relative accuracy specification plus the known error of the calibration reference relative to national standards (such as the U.S. National Institute of Standards and Technology). To be meaningful, the accuracy specifications must be accompanied with the conditions under which they are valid. These conditions should include temperature, humidity, and time.

There is no standard convention among instrument manufacturers for the confidence limits at which specifications are set. The table below shows the probability of non-conformance for *each specification* with the given assumptions.

Specification Criteria	Probability of Failure
Mean $\pm 2$ sigma	4.5%
Mean $\pm 3$ sigma	0.3%

Variations in performance from reading to reading, and instrument to instrument, decrease for increasing number of sigma for a given specification. This means that you can achieve greater actual measurement precision for a specific accuracy specification number. The 34970A/34972A is designed and tested to meet performance better than mean  $\pm 3$  sigma of the published accuracy specifications.

## **Interpreting Internal DMM Specifications**

### **24-Hour Accuracy**

The 24-hour accuracy specification indicates the internal DMM's relative accuracy over its full measurement range for short time intervals and within a stable environment. Short-term accuracy is usually specified for a 24-hour period and for a  $\pm 1$  °C temperature range.

### **90-Day and 1-Year Accuracy**

These long-term accuracy specifications are valid for a  $23$  °C  $\pm 5$  °C temperature range. These specifications include the initial calibration errors plus the internal DMM's long-term drift errors.

### **Temperature Coefficients**

Accuracy is usually specified for a  $23$  °C  $\pm 5$  °C temperature range. This is a common temperature range for many operating environments. You must add additional temperature coefficient errors to the accuracy specification if you are operating the internal DMM outside a  $23$  °C  $\pm 5$  °C temperature range (the specification is per °C).

## Configuring for Highest Accuracy Measurements

The measurement configurations shown below assume that the internal DMM is in its *Factory Reset* state. It is also assumed that manual ranging is enabled to ensure proper full scale range selection.

### ***DC Voltage, DC Current, and Resistance Measurements:***

- Set the resolution to 6 digits (you can use the 6 digits slow mode for further noise reduction).
- Set the input resistance to greater than 10 G $\Omega$  (for the 100 mV, 1 V, and 10 V ranges) for the best DC voltage accuracy.
- Use 4-wire ohms and enable offset compensation for the best resistance accuracy.

### ***AC Voltage and AC Current Measurements:***

- Set the resolution to 6 digits.
- Select the slow AC filter (3 Hz to 300 kHz).

### ***Frequency and Period Measurements:***

- Set the resolution to 6 digits.





---

# Index

*If you have questions relating to the operation of the 34970A/34972A, call 1-800-452-4844 in the United States, or contact your nearest Agilent Technologies Sales Office.*

---

## Symbols

- "½" digit, 117
- "B" (Mx+B scaling offset), 136
- "half" digit, 117
- "M" (Mx+B scaling gain), 136
- "OPEN T/C" message, 125
- \*RST command, 196
- \*TRG command, 98

## Numerics

- 34901A module
  - channel numbering, 200
  - description, 200
  - module overview, 12, 200
  - screw terminal diagram, 201
  - simplified schematic, 200
  - wiring log, 201
- 34902A module
  - channel numbering, 202
  - description, 202
  - module overview, 12, 202
  - screw terminal diagram, 203
  - simplified schematic, 202
  - wiring log, 203
- 34903A module
  - channel numbering, 204
  - description, 204, 304
  - module overview, 13, 204
  - RC protection circuitry, 305
  - screw terminal diagram, 205
  - simplified schematic, 204
  - snubber circuitry, 305
  - wiring log, 205
- 34904A module
  - channel numbering, 206
  - combining matrices, 309
  - description, 206, 308
  - module overview, 13, 206
  - screw terminal diagram, 207
  - simplified schematic, 206
  - wiring log, 207

- 34905A module (50W)
  - channel numbering, 208
  - description, 208, 310
  - module overview, 13, 208
  - screw terminal diagram, 209
  - simplified schematic, 208
  - wiring log, 209
- 34906A module (75W)
  - channel numbering, 208
  - description, 208, 310
  - module overview, 13, 208
  - screw terminal diagram, 209
  - simplified schematic, 208
  - wiring log, 209
- 34907A module
  - 8-bit vs. 16-bit operations, 151, 157
  - ac vs. TTL threshold, 154
  - adding to scan list, 151, 155
  - binary format, 49, 151
  - channel numbering, 210
  - clearing the count (totalizer), 156
  - current limitations (DAC), 159, 317
  - decimal format, 49, 151
  - description, 210
  - driving microwave switches, 314
  - gate signal, 153
  - maximum totalizer count, 154
  - module overview, 14, 210
  - screw terminal diagram 211
  - simplified block diagrams, 210
  - Totalize Threshold* jumper, 154, 211
  - totalizer reset mode, 155
  - using alarms, 148
  - wiring log, 211
- 34908A module

- channel numbering, 212
- description, 212
- module overview, 14, 212
- screw terminal diagram 213
- simplified schematic, 212
- wiring log, 213

## 34970A

- block diagram, 64
- firmware revision, 167
- 4W annunciator, 8
- 50W RF switching 310
- 75W RF switching, 310

## A

- ABORT command, 95
- aborting a scan, 94, 95
- absolute time, 104
- ac bandwidth
  - ac current 133
  - ac voltage, 131
  - vs. channel delays, 106
- ac current
  - ac filter, 133, 281
  - connections, 28
  - low frequency filter, 133, 281
  - measurement ranges, 28, 133
  - settling time, 133, 281
- ac filter
  - definition, 131, 133, 281
  - vs. channel delays, 106
- ac measurement errors, 261
- ac settling time, 131, 133
- ac voltage measurements
  - ac filter, 131, 281
  - connections, 28
  - loading errors, 284
  - low frequency filter, 131, 281
  - ranges, 28, 130
  - settling time, 131, 281
  - signal conditioning, 279
  - true RMS measurements, 280

- actuator switching, 73, 304
  - address (GPIB)
    - factory setting, 182, 187, 188, 190
    - selecting, 7, 182, 187, 188, 190
  - address, channel number, 30
  - ADRS annunciator, 8
  - Advanced* key, 42, 121
  - ALARM annunciator, 141
  - ALARM annunciator, 8
  - alarm data, viewing, 143
  - Alarm* key, 41, 47, 142
  - alarm limits
    - annunciators, 141
    - clearing alarm outputs, 146
    - configuring, 47
    - default settings, 48, 142
    - interaction with Mx+B, 47, 140
    - output connector location, 9, 10
    - output connector pinout, 145
    - output latch mode, 145
    - output slope (polarity), 146
    - output track mode, 146
    - scan on alarm, 100
    - setting limits, 47
    - with readings, 104
  - Alarm Out* key, 41, 146
  - alarm output lines
    - clearing, 146
    - connector location, 9, 10
    - connector pinout, 145
    - latch mode, 145
    - slope (polarity), 146
    - track mode, 146
  - alarm queue, 48
    - clearing, 143
    - number of alarms, 139
    - output format, 144
    - storing alarms, 139, 143
  - alarms
    - alarm output lines, 145
    - annunciators, 141
    - default limit values, 142
    - description, 139
    - front-panel annunciators, 141
    - hardware output lines, 141, 145
    - interaction with Mx+B, 140
    - output connector, 145
    - setting limits, 143
    - storing in alarm queue, 139
    - storing in reading memory, 139
    - viewing alarm queue, 143
    - viewing reading memory, 143
    - while scanning, 92
    - with multifunction module, 148
  - Alarms* connector, 145
  - alpha (a) for RTDs
    - default, 127
    - values, 127
  - analog-to-digital conversion
    - explanation, 76
    - integrating technique, 76
    - non-integrating technique, 76
  - annunciators, 8, 141
  - aperture time
    - definition, 120
    - selecting, 120
  - application programs
    - C and C++, 248
    - Excel 7.0, 241, 242
  - attenuation, 256, 264, 307
  - automatic channel delays, 106
  - Automatic Logging 180
  - automatic recall, power-down, 57, 93
  - autorange, threshold values, 115
  - autozero
    - definition, 122
    - vs. integration time, 122
  - average responding error, 280
  - average, during scan, 91
  - AWG, wire gauge size, 256
- ## B
- backplane relays, 200, 202, 303
  - bandwidth (ac)
    - ac current, 133
    - ac voltage, 131
    - vs. channel delays, 106
  - bank switch, 200, 202, 212, 303
  - baud rate (RS-232)
    - factory setting, 54, 56, 184
    - selecting, 54, 56, 184
  - BenchLink Data Logger Software
    - installation, 25
    - on-line help, 26
    - software overview, 11
  - bias current, dc loading errors, 278
  - binary format, digital read, 49, 151
  - bits, vs. integration time, 120
  - block diagram
    - 34970A, 64
    - internal DMM, 74
  - BNC cable kits
    - 34905A, 209
    - 34906A, 209
  - braces ({}), syntax, 89
  - brackets ([ ]), syntax, 89
  - break-before-make switching, 298
  - bridge, strain gage, 295
  - buffering triggers, 99
  - bumpers, removing, 37
  - burden voltage, 288
- ## C
- C and C++ example programs, 248
  - cable kits (SMB-to-BNC)
    - 34905A, 209

- 34906A, 209
- cabling
  - attenuation, 256
  - capacitance, 256
  - coaxial, 67
  - dielectric withstand voltage, 255
  - errors, 259
  - flat ribbon, 67
  - nominal impedance, 255
  - resistance, 256
  - RS-232, 23, 61
  - shielded coaxial, 258
  - shielding, 258
  - specifications, 255
  - twisted pair, 67, 258
  - types, 67
  - wire gauge size, 256
- CALC:AVER command, 110
- calculation error, thermocouple, 273
- calendar
  - factory setting, 166
  - setting, 29, 166
- calibration
  - overview, 191
  - read count, 195
  - security code, 191
  - text message, 194
  - to secure, 193
  - to unsecure, 192
- calibration certificate, 23
- capacitance, cable, 256
- capacitive coupling, 258, 301
- Card Reset* key, 33
- carrying handle
  - adjusting, 36
  - removing, 36
- celsius, setting units, 123
- Channel Advance (external scanning)
  - connector, 9, 10
  - operation, 112
- Channel Closed (external scanning)
  - connector, 9, 10
  - operation, 112
- channel configuration
  - copying, 32
  - front panel, 30
- channel delay
  - automatic, 106
  - default values, 105
  - defined, 105
  - settings, 105
- channel list
  - building from front panel, 94
  - building from remote, 95
  - examples, 89
  - rules, 89
- channel number, with readings, 104
- channel numbering, 30
  - 34901A, 200
  - 34902A, 202
  - 34903A, 204
  - 34904A, 206
  - 34905A, 208
  - 34906A, 208
  - 34907A, 210
  - 34908A, 212
- chassis ground, 9, 10
- clearing reading memory, 91
- clock
  - factory setting, 166
  - setting the, 29, 166
- Close* key, 33
- coaxial cables, 67, 258
- coefficient, temperature, 286
- color codes, thermocouples, 271
- command syntax (SCPI)
  - conventions, 89
  - version query, 173
- common LO multiplexers, 71, 298
- common mode noise, 273
- CONFIG annunciator, 8
- CONFigure command, 95
- connections
  - 2-wire resistance, 28
  - 4-wire resistance, 28
  - ac current, 28
  - ac voltage, 28
  - dc current, 28
  - dc voltage, 28
  - frequency, 28
  - period, 28
  - RTD, 28
  - thermistor, 28
  - thermocouples, 28
- connector location
  - Alarm output, 9, 10, 145
  - Channel Advance, 9, 10
  - Channel Closed, 9, 10
  - Ext Trig, 9, 10, 99
  - GPIB, 9
  - RS-232, 9
- connector pinout
  - alarm output, 145
- contact
  - debounce (totalizer), 316
  - protection, 305
  - resistance, 319
- continuous scan count, 102
- conversion accuracy
  - RTD, 265
  - thermistor, 265
  - thermocouple, 265
- copying, channel configuration, 32
- correlated noise, 261, 285
- count
  - calibration, 195
  - clearing relay cycles, 170
  - reading relay cycles, 169, 319

- count (scan)
  - continuous, 45, 102
  - default value, 45, 102
  - settings, 45, 102
- count-down time, 97
- counter
  - adding to scan list, 51
  - manually reset, 51
  - reading count, 51
  - reset mode, 51
- crest factor
  - defined, 282
- crosspoint switching, 72
- current limitation (DAC), 159, 317
- current measurements
  - ac low frequency filter, 133, 281
  - ac settling time, 133, 281
  - burden voltage, 288
  - connections, 28
  - low frequency filter, 133, 281
  - measurement ranges, 28, 133
  - valid channels, 133
- custom label (Mx+B)
  - displaying "0" character, 137
  - valid characters, 137
- cycles
  - clearing relay count, 170
  - reading relay count, 169, 319
- D**
- DAC output (34907A)
  - current limitations, 159, 317
  - differential error, 318
  - integral error, 318
  - simplified schematic, 317
  - writing to, 52
- data acquisition overview, 60
- data bits (RS-232)
  - factory setting, 184
  - selecting, 184
- DATA:LAST? command, 110
- DATA:POINts? command, 110
- DATA:REMOve? command, 110
- date (calendar)
  - factory settings, 166
  - setting, 29, 166
- dc current
  - connections, 28
  - measurement ranges, 28
- dc voltage
  - bias current, 278
  - common mode noise, 274
  - connections, 28
  - injected current, 276
  - input resistance, 130, 277
  - loading errors, 277
  - measurement ranges, 28, 130
  - signal conditioning, 274
- decimal format (digital input), 49, 151
  - default delays (channel delays), 106
- Default Gateway 190
- delay (channel delay), 105
- DHCP 188
- dielectric withstand voltage, 255
- differential error, (DAC), 318
- diffusion error, 272
- digital channels, external scanning, 113
- digital input (34907A)
  - 8-bit vs. 16-bit operations, 151
  - adding to scan list, 49, 151
  - binary format, 49, 151
  - block diagram, 210
  - card reset, 151, 152
  - decimal format, 49, 151
  - scanning, 92
  - simplified schematic, 312
  - using alarms, 148
- digital output (34907A)
  - 8-bit vs. 16-bit operations, 157
  - binary format, 50, 157
  - card reset, 157
  - decimal format, 50, 157
  - driving microwave switches, 314
  - simplified schematic, 313
  - sink current, 313
  - TTL drive capability, 313
- digits
  - number of, 117
  - vs. integration time, 120
- DIN/IEC 751, 123
- disabling internal DMM, 112
- display
  - annunciators, 8
  - enable/disable, 165
  - text message, 165
- dissimilar metals, 260
- DMM (internal)
  - block diagram, 263
  - enabling/disabling, 167, 169
  - reading relay count, 169
- DNS Server 190
- DTR/DSR flow mode (RS-232), 185
- Dynamic Host Configuration Protocol 188
- E**
- E5810A LAN-to-GPIB, 61
- ERROR annunciator, 8, 163, 216
- error messages, 215–238
- errors
  - ac loading, 284
  - cabing, 259
  - capacitive coupling, 301
  - clearing, 163
  - common mode noise, 273
  - diffusion error, 272
  - frequency measurements, 297
  - loading, dc voltage, 277

- loading, input bias current, 278
- low-level ac, 261
- magnetic fields, 260
- multiplexing and switching, 301
- period measurements, 297
- reading error queue, 163, 216
- RF multiplexing, 311
- thermal EMF, 260
- thermocouple calculation, 273
- thermocouple reference junction, 272
- totalizer, 316
- example programs
  - C and C++, 248
  - Excel 7.0, 241
- Excel macro example programs, 241
- Exporting readings to USB 180
- Express Exchange program, 15
- EXT annunciator, 8
- Ext Trig* connector, 9, 10, 99, 111
- external DMM
  - connections, 111
  - scanning with, 111
- external reference (T/C), 124
- external scanning
  - connections, 111
  - with digital channels, 113
- external trigger
  - connector, 9, 10, 99, 111
  - scan interval, 96
- F**
- factory reset state, 196
- fahrenheit, setting units, 123
- fast ac filter, 131, 133, 134, 281
- fast timeout, 135
- FETCh? command
  - description, 95
- filler panel kit (rack mounting), 38
- filter, ac signal, 131, 133, 134, 281
- firmware revision
  - 34970A, 167
  - plug-in modules, 167
- fixed input range (dc voltage), 130
- fixed reference (thermocouple), 124
- flange kit (rack mounting), 38
- flow mode (RS-232)
  - DTR/DSR mode, 185
  - factory setting, 54, 185
  - Modem mode, 186
  - None (no flow mode), 185
  - RTS/CTS mode, 185
  - selecting, 54, 185
  - XON/XOFF mode, 185
- form C (SPDT) switching, 73, 304
- format
  - alarm queue data, 144
  - scanned readings, 104
- four-wire multiplexers, 71, 300
- four-wire ohms, 132, 289
- four-wiring paring (RTD), 127
- frequency measurements
  - connections, 28
  - low frequency timeout, 135
  - sources of error, 297
- front panel
  - annunciators, 8
  - defining scan list, 30
  - layout, 6
  - menu overview, 7, 39
- front-panel display
  - enable/disable, 165
  - text message, 165
- fuse
  - factory setting, 34
  - location, 9, 10, 35
  - part number, 34
  - replacing, 35
- fuseholder assembly, 9, 10, 35
- G**
- gage factor (strain), 294
- gain "M" (Mx+B) scaling, 46, 136
- gate signal (totalizer), 153, 316
- gauge, wire size, 256
- GET (Group Execute Trigger), 98
- GPIB (IEEE-488)
  - address selection, 9, 53, 55, 183
  - cable, 61
  - connector, 9
  - factory address setting, 174, 180, 182, 187
  - interface selection, 53, 55, 183
  - setting address, 174, 180, 182, 187
- ground loops, 257, 261
- grounding, 257
- H**
- handle
  - adjusting, 36
  - removing, 37
- handshake (RS-232)
  - DTR/DSR mode, 185
  - factory setting, 54, 185
  - Modem mode, 186
  - None (no flow mode), 185
  - RTS/CTS mode, 185
  - selecting, 54, 185
  - XON/XOFF mode, 185
- hardware output lines (alarms), 145
- hardware, rack mounting, 38
- high-frequency switching, 310
- I**
- ice bath, 268
- IEEE-488 (GPIB)

- address selection, 53, 55, 183
  - cable, 61
  - connector, 9
  - factory address setting, 182, 187, 188, 190
  - interface selection, 53, 55, 183
  - setting address, 182, 187, 188, 190
  - impedance mismatching, 311
  - INITiate command
    - description, 95
  - injected current, dc voltage, 276
  - input resistance
    - dc loading errors, 277
    - dc voltage, 130, 131, 277
  - INPut:IMP:AUTO command, 131
  - insertion loss, 311
  - installing
    - BenchLink Data Logger software, 25
  - Instrument configuration, importing 181
  - instrument preset state, 197
  - instrument state storage
    - definition, 57
    - front-panel operation, 161
    - naming states, 57, 160
    - power-down recall, 160
    - remote operation, 161
  - integral error (DAC), 318
  - integrating ADC, 76
  - integration time
    - definition, 120
    - selecting, 120
    - vs. channel delays, 106
    - vs. number of bits, 120
    - vs. number of digits, 120
    - vs. resolution, 120
  - Interface* key, 43, 53, 55, 183
  - interface, GPIB (IEEE-488)
    - address selection, 53, 55, 183
    - cable, 61
    - connector, 9
    - factory address setting, 182
    - interface selection, 53, 55, 183
    - setting address, 182
  - interface, RS-232 (serial)
    - baud rate, 54
    - cable, 61
    - flow control, 54
    - parity, 54
    - stop bits, 54
  - internal DMM
    - block diagram, 263
    - enabling/disabling, 167
    - reading relay count, 169
  - internal reference (thermocouple), 124
  - internal timer, scan interval, 124
  - Interval* key, 42, 97, 113
  - interval scan
    - default value, 97
    - resolution, 97
    - setting from front panel, 97
    - setting from remote, 97
    - settings, 97
  - interval, scan-to-scan, 45, 96
  - IP address 189
  - IPTS-68 conversions, 127, 266
  - isothermal block, 124, 270
  - ITS-90 conversions, 127, 266
- J**
- jumper, *Totalize Threshold*, 154, 211
  - junction temperature, 267
- K**
- kelvins, setting units, 123
- L**
- labels
    - Mx+B scaling, 46, 137
    - stored states, 57
  - LAN Connectivity 187
  - LAN, Resetting 187
  - language, SCPI syntax
    - conventions, 89
    - version query, 173
  - LAN-to-GPIB Gateway, 61
  - LAST annunciator, 8
  - latch mode, alarm output lines, 145
  - limits (alarms)
    - annunciators, 142
    - clearing alarm outputs, 146
    - configuring, 47
    - default settings, 48, 142
    - interaction with Mx+B, 47, 140
    - output connector location, 9, 10
    - output connector pinout, 145
    - output latch mode, 145
    - output slope (polarity), 146
    - output track mode, 146
    - scan on alarm, 100
    - setting limits, 47
    - with readings, 104
  - line voltage
    - factory setting, 34
    - fuse, 34
    - selection, 34
    - selector module, 9, 35
  - loading errors
    - ac voltage, 284
    - dc input resistance, 277
    - input bias current, 278
  - lock-link kit (rack mounting), 38
  - low frequency limit
    - ac current, 133
    - frequency, 135

- 
- M**
- MAC Address 190
  - magnetic field errors, 260
  - mainframe
    - firmware revision, 167
  - maintenance
    - clearing relay count, 169
    - reading relay count, 169, 319
  - matrix switching, combining, 308
  - MAX annunciator, 8
  - maximum reading, during scan, 169
  - Measure* key, 30, 32, 41, 94
  - MEASure? command, 95
  - Measurement Complete* signal, 112
  - measurement range
    - autorange, 115
    - overload, 115
    - selecting, 116
  - measurement resolution
    - "half" digit, 117
    - selecting, 118
    - vs. integration time, 120
  - measurement tutorial, 253
  - medium ac filter, 131, 133, 281
  - medium frequency timeout, 135
  - MEM annunciator, 8
  - memory
    - reading scanned readings, 107
    - viewing alarm data, 143
    - viewing scanned data, 31
  - menus
    - front panel, 7, 39
    - summary, 41
  - message
    - calibration, 194
    - errors, 215–238
    - front-panel display, 165
  - Microsoft Visual C++, 248
  - microwave switches, driving, 314
  - MIN annunciator, 8
  - minimum reading, during scan, 91
  - modem
    - flow control mode (RS-232), 186
  - module description
    - 34901A, 200
    - 34902A, 202
    - 34903A, 204
    - 34904A, 206
    - 34905A, 208
    - 34906A, 208
    - 34907A, 210
    - 34908A, 212
  - module information
    - default settings, 198
    - firmware revision, 167
    - reading relay count, 169
  - Mon* key, 44, 172
  - MON annunciator, 8
  - Monitor function
    - definition, 171
    - scan on alarm, 101, 172
    - while scanning, 91
    - with alarms, 171
    - with Mx+B scaling, 171
  - multiplexer types, 298
  - multiplexers
    - errors, 301
    - four-wire, 71, 300
    - one-wire (single-ended), 71, 298
    - two-wire, 71, 298
    - VHF, 71
  - Mx+B* key, 41, 46
  - Mx+B scaling
    - custom label, 46, 137
    - default gain ("M"), 136, 138
    - default offset ("B"), 136, 138
    - equation used, 136
    - interaction with alarms, 136
    - null stored as offset, 136
    - setting gain ("M"), 46, 138
    - setting offset ("B"), 46, 138
    - strain measurements, 295
    - valid gain ("M") values, 137
    - valid offset ("B") values, 137
    - while scanning, 91, 136
- N**
- name, stored states, 57
  - noise caused by ground loops, 261
  - noise rejection, normal mode, 120
  - nominal impedance, cabling, 255
  - nominal resistance (RTD)
    - default, 127
    - values, 127
  - normal mode rejection, 120, 264
  - NPLC, 120, 264
    - vs. channel delays, 106
  - null, stored as offset ("B"), 137
  - number of bits
    - vs. integration time, 120
  - number of digits, 117
    - vs. integration time, 120
- O**
- OC annunciator, 8
  - offset "B" (Mx+B) scaling, 46, 136
  - offset compensation, 132, 291
  - offset voltages, 122
  - On/Standby* switch, 23
  - ONCE annunciator, 8
  - Open* key, 33
  - output format, alarm queue data, 144
  - output lines, alarms, 141, 145
- P**
- parity (RS-232)
    - factory setting, 184
    - selecting, 54, 184

- pasting, channel configuration, 32  
 PCL, 120, 264  
     vs.channel delays, 106  
 period measurements  
     connections, 28  
     sources of error, 297  
 plug-in module description  
     34901A, 200  
     34902A, 202  
     34903A, 204  
     34904A, 206  
     34905A, 208  
     34906A, 208  
     34907A, 210  
     34908A, 212  
 plug-in module information  
     connecting wiring, 27  
     default settings, 198  
     firmware revision, 167  
     installing in mainframe, 27  
     reading relay count, 169  
     strain relief, 27  
 poisson strain, 293  
 polarity, alarm output lines, 146  
 Power (Standby) switch, 23  
 power cord, 23  
 power failure, during scan, 93  
 power line cycles, 120, 264  
 power-down recall, 57, 93, 160  
 power-line fuse  
     factory setting, 34  
     location, 9, 10, 35  
     part number, 34  
     replacing, 35  
 power-line voltage  
     factory setting, 34  
     fuse, 34  
     selection, 34  
     selector module, 35  
 power-line, rejecting noise, 264  
 preset state, 197  
 programming examples  
     C and C++, 248, 249  
     Excel 7.0, 241, 242, 243  
 PT100 (RTD), 127, 266  
**Q**  
 quick start 21  
 Quick Start Kit, 23  
**R**  
 R0 (RTD)  
     default, 127  
     range, 127  
 rack mounting  
     filler panel, 38  
     flange kit, 38  
     lock-link kit, 38  
     removing bumpers, 37  
     removing handle, 37  
     sliding-shelf kit, 38  
 radio frequency interference, 259  
 random noise, 297  
 range  
     autorange, 115  
     overload, 115  
     selecting, 116  
 ranges by function  
     2-wire ohms, 28, 132  
     4-wire ohms, 28, 132  
         ac current, 28, 133  
         ac voltage, 28, 130  
         dc current, 28, 133  
         dc voltage, 28, 130  
 RC protection circuitry, 305  
*Read* key, 49, 51  
 READ? command, 95  
 reading format, 104  
 readings memory, storing alarms, 139  
 readings, viewing, 31, 107  
 real-time clock  
     factory setting, 166  
     setting, 29, 166  
 rear panel  
     external scanning, 111  
     pictorial overview, 9, 10  
 recall power-down state, 160  
 reference junction (thermocouple)  
     definition, 124  
     external reference, 124  
     fixed temperature, 124  
     internal reference, 124  
     reference channel, 124  
 reference thermocouple, 269  
 relative time, 104  
 relay contact protection, 305  
 relay contact resistance, 319  
 relay cycle count  
     clearing, 170  
     estimating relay life, 319  
     reading, 169, 319  
 relay life, 320  
     relay maintenance system,  
         319  
     vs. load switched, 320  
 relay maintenance system  
     clearing relay count, 170  
     reading relay count, 169, 319  
 remote interface, 53, 55  
 remote interface, GPIB (IEEE-488)  
     address selection, 53, 55, 183  
     cable, 61  
     interface selection, 53, 55, 183  
 remote interface, RS-232 (serial)  
     baud rate, 54, 56  
     cable, 61  
     flow control, 54  
     parity, 54  
     stop bits, 54  
 reset mode, totalizer, 51, 92  
 resistance measurements



- 2-wire ohms, 289
- 4-wire ohms, 289
- connections, 28
- nominal (RTD), 127
- offset compensation, 132, 291
- ranges, 28
- resolution,
  - "half" digit, 117
  - selecting 118
  - vs. integration time, 120
- revision number (firmware)
  - 34970A, 167
  - plug-in modules, 167
- RF cable kits (SMB to BNC), 209
- RF multiplexers
  - insertion loss, 311
  - sources of error, 311
  - VSWR, 311
- RFI radiation, 259
- ribbon cables, 67
- RMT annunciator, 8
- rosette (strain gage), 294
- ROUTe:CHAN:ADV:SOUR command, 114
- ROUTe:CHAN:DElAy command, 105
- ROUTe:CHAN:FWIRe command, 114
- ROUTe:MON:DATA? command, 172
- ROUTe:MON:STATe command, 172
- ROUTe:SCAN command, 95
- RS-232 (serial) interface
  - baud rate, 184
  - cable, 23, 61
  - connector location, 9
  - flow mode, 185
  - parity, 184
  - selecting interface, 183
- RTD measurements, 127
- alpha (a), 127
- connections, 28
- conversion accuracy, 265
- measurement tutorial, 266
- measurement units, 123
- supported types, 28, 123
- RTS/CTS flow mode (RS-232), 185
- rubber bumpers, removing, 37
- S**
- safety notices 3
- Sample (\*) annunciator, 8
- sample programs
  - C and C++, 248
  - Excel 7.0, 241
- scale, temperature units, 123
- scaling (Mx+B)
  - custom label, 46, 137
  - default gain ("M"), 136, 138
  - default offset ("B"), 136, 138
  - equation used, 136
  - interaction with alarms, 136
  - null stored as offset, 136
  - setting gain ("M"), 46, 138
  - setting offset ("B"), 46, 138
  - strain measurements, 295
  - valid gain ("M") values, 137
  - valid offset ("B") values, 137
  - while scanning, 91, 136
- SCAN annunciator, 8
- scan configuration, copying, 32
- scan configuration, front panel, 30
- scan count
  - continuous, 45, 102
  - default value, 45, 102
  - settings, 45, 102
- scan interval
  - default value, 45, 97
  - resolution, 97
  - setting from front panel, 97
  - setting from remote, 97
- Scan key, 31, 94
- scan list
  - adding channels to, 94
  - building from front panel, 94
  - building from remote, 95
  - defining, 30–31
  - examples, 89
  - reading digital input, 49
  - reading totalizer count, 51
  - rules, 89
- scan sweep, defined, 96
- scanning
  - aborting a scan, 94, 95
  - alarm mode, 100
  - channel delay, 105
  - clearing memory, 91, 94, 95
  - external mode, 99
  - external scan with digital input, 113
  - initiating from front panel, 94
  - initiating from remote, 95
  - interval (timer) mode, 97
  - interval trigger, 96
  - manual (once) mode, 98
  - memory overview, 91
  - modules allowed, 90
  - on alarm, 100
  - power failure, 93
  - reading format, 104
  - readings stored in memory, 91
  - removing modules during, 92
  - rules, 90
  - scan once (manual) mode, 98
  - statistics, 91
  - stopping scan, 97
  - storing readings, 92
  - timer (interval) mode, 97
  - viewing readings, 107
  - with alarms, 92
  - with digital input channels, 92

- with external instrument, 111
  - with Monitor function, 91
  - with Mx+B scaling, 91
  - with totalizer channels, 92
- SCPI language
- syntax conventions, 89
  - vision query, 173
- screw terminal connections
- ac current, 28
  - ac voltage, 28
  - dc current, 28
  - dc voltage, 28
  - frequency, 28
  - period, 28
  - resistance, 28
  - RTDs, 28
  - thermistors, 28
  - thermocouples, 28
  - wiring strain relief, 27
  - wiring strip length, 27
- screw terminal diagram
- 34901A, 201
  - 34902A, 203
  - 34903A, 205
  - 34904A, 207
  - 34905A, 209
  - 34906A, 209
  - 34907A, 211
  - 34908A, 213
- secure calibration, 193
- security code (calibration)
- factory setting, 191
  - to change, 193
- self-test
- complete, 24
  - failure, 24
  - power-on, 24
- sense connections (RTD), 127
- sense connections, 300
- sensor types, 68
- serial (RS-232) interface
- baud rate, 184
  - cable, 23, 61
  - connector location, 9
  - flow mode, 185
  - parity, 184
  - selecting interface, 183
- settling delay
- automatic, 106
  - default value, 105
  - defined, 105
  - settings, 105
- settling time, 292
- settling time, ac voltage, 281
- shearing strain, 293
- shielding, 258
- shielding, thermocouple wire, 273
- SHIFT annunciator, 8, 22
- Shift* key, 22
- shunt impedance, 273
- signal conditioning, 76
- ac voltage, 279
  - dc voltage, 274
- simplified schematic,
- 34901A, 200
  - 34902A, 202
  - 34903A, 204
  - 34904A, 206
  - 34905A, 208
  - 34906A, 208
  - 34907A, 210
  - 34908A, 212
- single-channel Monitor, 171, 172
- sink current, digital output, 313
- sliding-shelf kit (rack mounting), 38
- slope, alarm output lines, 146
- slot numbering, 9, 10
- slow ac filter, 131, 281
- slow timeout, 135
- SMB cable kits, 209
- snubber circuitry, 305
- software (BenchLink Data Logger)
- installation, 25
  - on-line help, 26
  - overview, 11
- source connections (RTD), 127
- source connections, 300
- SPDT (Form C) switching, 73, 304
- Standby (Power) switch, 23
- state storage
- definition, 57
  - front-panel operation, 161
  - naming states, 57, 160
  - power-down recall, 160
  - remote operation, 161
- statistics, while scanning, 91
- Status of LAN Connectivity 187
- status register
- example program, 250
- Step* key, 31, 94
- Sto / Rcl* key, 43, 57
- stopping scan, 97
- stored states
- definition, 57
  - front-panel operation, 161
  - naming states, 57, 160
  - power-down recall, 160
  - remote operation, 161
- strain gage
- common uses, 294
  - gage factor, 294
  - measurements, 137, 293
  - Mx+B equations, 137
  - poisson strain, 293
  - rosette, 294
  - shearing strain, 293
  - Wheatstone bridge, 295
- strain relief, 27, 255
- stress (strain gage), 293
- strip length, wiring, 27
- Subnet Mask 189
- sweep (scan), defined, 94, 96

- switch contact resistance, 319
- switch life, 319
- switch types
  - form C (SPDT), 73
  - matrix, 72
  - multiplexer, 71, 298
- switching, errors, 301
- syntax, SCPI conventions, 89
- system cabling, 67, 255
- system clock
  - factory setting, 166
  - setting the, 29, 166
- SYSTem:ERRor? command, 216
- SYSTem:PRESet command, 197
  
- T**
- technical support
  - phone numbers 3
  - Web site 3
- temperature coefficient, 286
- temperature conversion accuracy, 265
- temperature measurements
  - RTDs, 127
  - thermistors, 129
  - thermocouples, 124
- temperature units, 123
- terminal connections
  - ac current, 28
  - ac voltage, 28
  - dc current, 28
  - dc voltage, 28
  - frequency, 28
  - period, 28
  - resistance, 28
  - RTDs, 28
  - thermistors, 28
  - thermocouples, 28
  - wire strain relief, 27
  - wire strip length, 27
- thermal EMF errors, 260
  
- thermistors
  - connections, 28
  - conversion accuracy, 265
  - measurement tutorial, 129, 266
  - measurement units, 123
  - types supported, 28, 123
- Thermocouple Check* feature, 125
- thermocouples
  - calculation error, 273
  - color codes, 271
  - connections, 28
  - conversion accuracy, 265
  - diffusion error, 272
  - external reference, 124
  - fixed reference, 124
  - internal reference, 124
  - isothermal block, 124
  - measurement tutorial, 267
  - measurement units, 123
  - metals used, 271
  - probe accuracy, 271
  - reference junction error, 272
  - reference junction, 124
  - shielding, 273
  - shunt impedance, 273
  - temperature range, 271
  - Thermocouple Check*, 125
  - types supported, 28
- thermoelectric voltages, 260
- threshold, totalize, 154–156
- time (clock)
  - factory setting, 166
  - setting the, 29, 166
- time stamp
  - absolute, 104
  - relative, 104
- timeout, low frequency, 135
- torroid 259
- totalize threshold, 154
  - hardware jumper, 315
  
- totalizer
  - ac vs. TTL threshold, 154
  - adding to scan list, 51, 155
  - block diagram, 315
  - clearing the count, 156
  - contact bounce, 316
  - counting on falling edge, 153
  - counting on rising edge, 153
  - errors, 316
  - gate signal, 153, 316
  - manually reset, 51
  - maximum count, 154, 315
  - reading count, 51
  - reset mode while scanning, 92
  - reset mode, 51, 155
  - scanning, 92
  - Totalize Threshold* jumper, 154
- track mode, alarm output lines, 146
- transducer types, 68
- tree switch, 303
- triangle brackets (<>), syntax, 89
- TRIG:SOUR command, 97
- TRIG:TIMER command, 97
- TRIGGER command, 98
- TRIGger:COUNT command, 103
- triggering
  - buffering, 99
  - external, 99
  - scan, 96
- troubleshooting
  - error messages, 215–238
- true RMS, 280
- TTL drive, digital output, 313
- tutorial 253
- twisted pair cables, 67
- two-wire multiplexers, 71, 298
- two-wire ohms, 289

- U**
- UNIT:TEMP command, 123
- units
  - temperature, 123
  - with readings, 104
- unsecure calibration, 192
- USB Front Panel 180
- USB, exporting readings 180
- USB, formatting readings 180
- USB, importing an instrument configuration 181
- Utility* key 42
- V**
- varistor, 306
- vertical bar ( | ), syntax, 89
- VIEW annunciator, 8
- View* key, 31, 42, 109, 143
- viewing
  - alarm data, 143
  - readings, 107
  - scanned readings, 31
- Visual Basic, example, 241
- VM Complete* signal, 112
- voltage (DAC) output
  - card reset, 159
  - current limitations, 159, 317
  - differential error, 318
  - integral error, 318
  - resetting, 52
  - simplified schematic, 317
  - writing, 52
- voltage dividers, 305
- voltage measurements, 130
  - ac low frequency filter, 131
  - ac settling time, 131
- VSWR, 311
- W**
- Warnings**
  - 34901A, 201
  - 34902A, 203
  - 34903A, 205
  - 34904A, 207
  - 34908A, 212
- warranty 2
- waveform tutorial, 253
- Wheatstone bridge (strain), 295
- wire size (gauge), 256
- wiring connections
  - ac current, 28
  - ac voltage, 28
  - dc current, 28
  - dc voltage, 28
  - frequency, 28
  - period, 28
  - resistance, 28
  - RTDs, 28
  - thermistors, 28
  - thermocouples, 28
  - wiring strain relief, 27
  - wiring strip length, 27
- wiring log
  - 34901A, 201
  - 34902A, 203
  - 34903A, 205
  - 34904A, 207
  - 34905A, 209
  - 34906A, 209
  - 34907A, 211
  - 34908A, 213
- Write* key, 50, 52
- X**
- XON/XOFF annunciator, 185
- Z**
- ZERO:AUTO command, 122