Service Guide

Publication number 16760-97015
May 2005

For Safety and Regulatory information see the pages at the end of the book.

© Copyright Agilent Technologies 2001-2005
All Rights Reserved.

Agilent Technologies 16760A Logic Analyzer

The Agilent 16760A Logic Analyzer—At a Glance

The Agilent Technologies 16760A is a 1500 Mb/s state, 800 MHz timing logic analyzer module for the Agilent Technologies 16700-series or 16900-series logic analysis system. The 16760A offers high performance measurement capability.

Features

Some of the main features of the 16760A are as follows:

- 32 data channels.
- 2 clock/data channels.
- 128 Mb memory depth per channel.
- 1500 MHz maximum state acquisition speed.
- 800 MHz maximum timing acquisition speed.
- Expandable to 170 channels.

Service Strategy

The service strategy for this instrument is the replacement of defective assemblies. This service guide contains information for finding a defective assembly by testing and servicing the 16760A state and timing analyzer module.

The modules can be returned to Agilent Technologies for all service work, including troubleshooting. Contact your nearest Agilent Technologies Sales Office for more details.

Application

This service guide applies to a 16760A module installed in 16700-series or 16900-series logic analysis system mainframes.

In the 16700-series logic analysis system, the 16760A logic analyzer requires software version A.02.20.00 or higher. Agilent 16700-series mainframes with serial number prefixes lower than US4111 are factory-installed with older operating system versions.

In the 16900-series logic analysis system, the 16760A logic analyzer requires software version 03.20.0000 or higher.

If your logic analysis system software is older than the required version, contact your Agilent Technologies Service Center for newer software. Refer to “Mainframe and Operating System” on page 10 for more information.

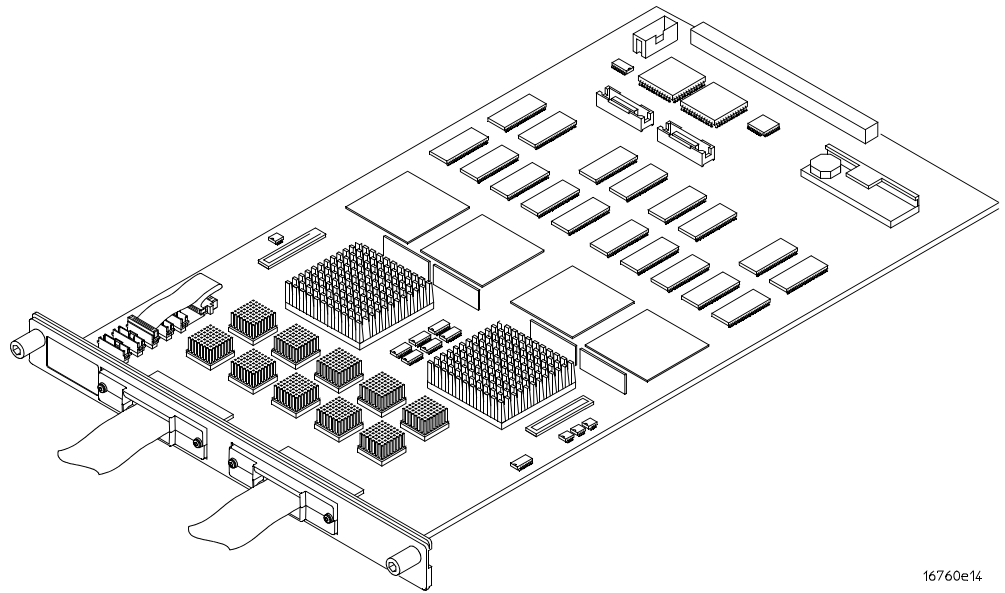

16760e14

The 16760A Logic Analyzer

In This Book

This book is the service guide for the 16760A 1500 Mb/s state, 800 MHz timing logic analyzer module.

This service guide has eight chapters.

Chapter 1, “General Information,” beginning on page 9 contains information about the module and includes accessories for the module, specifications and characteristics of the module, and a list of the equipment required for servicing the module.

Chapter 2, “Preparing for Use,” beginning on page 15 tells how to prepare the module for use.

Chapter 3, “Testing Performance,” beginning on page 19 gives instructions on how to test the performance of the module.

Chapter 4, “Calibrating,” beginning on page 119 contains calibration instructions for the module (if required).

Chapter 5, “Troubleshooting,” beginning on page 121 contains explanations of self-tests and flowcharts for troubleshooting the module.

Chapter 6, “Replacing Assemblies,” beginning on page 171 tells how to replace the module and assemblies of the module and how to return them to Agilent Technologies.

Chapter 7, “Replaceable Parts,” beginning on page 179 lists replaceable parts, shows an exploded view, and gives ordering information.

Chapter 8, “Theory of Operation,” beginning on page 185 explains how the analyzer works.

Contents

1 General Information

Accessories	10
Mainframe and Operating System	10
Specifications	11
Characteristics	12
Environmental Characteristics	12
Recommended Test Equipment	13

2 Preparing for Use

Power Requirements	16
Operating Environment	16
Storage	16
To inspect the module	17
To configure and install the module	17
To test the module	17
To clean the module	18

3 Testing Performance

Overview	20
16900-Series vs. 16700-Series Mainframes	20
Manual Performance Test Strategy	20
Test Interval	21
Test Record Description	21
Test Equipment Required	22
Instrument Warm-Up	22
Assemble the SMA/Flying Lead Test Connectors	23
Run the Software (Self) Tests	27
On a 16900-Series Mainframe	27
On a 16700-Series Mainframe	29
Initialize the Test Equipment for Manual Tests	31
Connect the Test Equipment for Manual Tests	33
Connect the 16760A Logic Analyzer Pod to the 8133A Pulse Generator	33
Connect the 8133A Pulse Generator Output to the 54845A Oscilloscope	35

Contents

Set Up the Test Equipment for Manual Tests	36
Verify and Adjust the 8133A Pulse Generator DC Offset	36
Deskew the Oscilloscope	37
Adjust the Measured Pulse Width to 1.5 ns	38

Manual Test Procedure, 16900-Series Mainframe	40
Test Pod 1 in 200 Mb/s Mode	40
Test Pod 2 in 200 Mb/s Mode	50
Test Pod 1 in 400 Mb/s mode	52
Test Pod 2 in 400 Mb/s mode	57
Test Pod 1 in 800 Mb/s mode	59
Test Pod 2 in 800 Mb/s mode	65
Test Pod 1 in 1250 Mb/s mode	66
Test Pod 2 in 1250 Mb/s mode	70
Test Pod 1 in 1500 Mb/s mode	72
Test Pod 2 in 1500 Mb/s mode	77

Manual Test Procedure, 16700-Series Mainframe	79
Test Pod 1 in 200 Mb/s Mode	79
Test Pod 2 in 200 Mb/s Mode	91
Test Pod 1 in 400 Mb/s mode	93
Test Pod 2 in 400 Mb/s mode	97
Test Pod 1 in 800 Mb/s mode	98
Test Pod 2 in 800 Mb/s mode	104
Test Pod 1 in 1250 Mb/s mode	105
Test Pod 2 in 1250 Mb/s mode	109
Test Pod 1 in 1500 Mb/s mode	110
Test Pod 2 in 1500 Mb/s mode	115

Complete Multi-Card Module Testing	117
------------------------------------	-----

Performance Test Record	118
-------------------------	-----

4 Calibrating

Calibration Strategy	120
----------------------	-----

5 Troubleshooting

To use the flowcharts	123
To run the self-tests	126
On a 16900-Series Mainframe	126
On a 16700-Series Mainframe	126

Contents

Self-Test Descriptions 128

To exit the test system 134

On a 16900-Series Mainframe 134

On a 16700-Series Mainframe 134

To test the cables using an E5378A single-ended probe 135

On a 16900-Series Mainframe 135

On a 16700-Series Mainframe 146

To test the cables using E5379A differential probes 154

On a 16900-Series Mainframe 154

On a 16700-Series Mainframe 164

6 Replacing Assemblies

Tools Required 172

To remove the module 172

To remove the logic analyzer cable 173

To install the logic analyzer cable 174

To replace the circuit board 176

To return assemblies 177

7 Replaceable Parts

Replaceable Parts Ordering 180

Replaceable Parts List 181

Exploded View 183

E5382A Accessories 184

8 Theory of Operation

Block-Level Theory 186

Index

General Information

This chapter lists the accessories, the specifications and characteristics, and the recommended test equipment.

Accessories

One or more of the following accessories, not supplied, are required to operate the 16760A logic analyzer.

Accessories	Agilent Part Number
Single-ended soft touch probe	E5390A
Differential soft touch probe	E5387A
100-pin single-ended probe	E5378A
100-pin differential probe	E5379A
38-pin single-ended probe	E5380A
Single-ended flying lead probe set	E5382A
Differential flying lead probe set	E5381A

Mainframe and Operating System

In the 16700-series logic analysis system, the 16760A logic analyzer requires software version A.02.20.00 or higher. However, the specifications apply to operating system version A.02.60.00 or higher. The mainframe operating system must be upgraded to version A.02.60.00 before attempting the performance verification procedure in Chapter 3. Agilent 16700-series mainframes with serial number prefix lower than US4148 are factory-installed with operating system versions older than A.02.60.00.

In the 16900-series logic analysis system, the 16760A logic analyzer requires software version 03.20.0000 or higher.

If the proper system software version is not loaded, obtain a copy of the updated system software and install it in the logic analyzer mainframe. You can request a 16700-series software upgrade at <http://software.cos.agilent.com/16700>, download the latest 16900-series software from http://www.agilent.com/find/16900_SW_Download, or contact your nearest Agilent Technologies Customer Support Center.

Three Cooling Fans Required in 16700-Series Mainframe

Earlier versions of the 16700A/01A/02A mainframe contained only two cooling fans and might not provide adequate cooling to ensure reliable performance. If the first six digits of the 16700A/02A serial number (located on the back of the instrument) are US3849 or higher, or the first six digits of the 16701A are US3902 or higher, the instrument is a three-fan model, which will supply sufficient cooling.

All 16700B/01B/02B systems already have three cooling fans which provide adequate cooling to ensure reliable performance.

Specifications

The specifications are the performance standards against which the product is tested.

Setup/Hold Window:

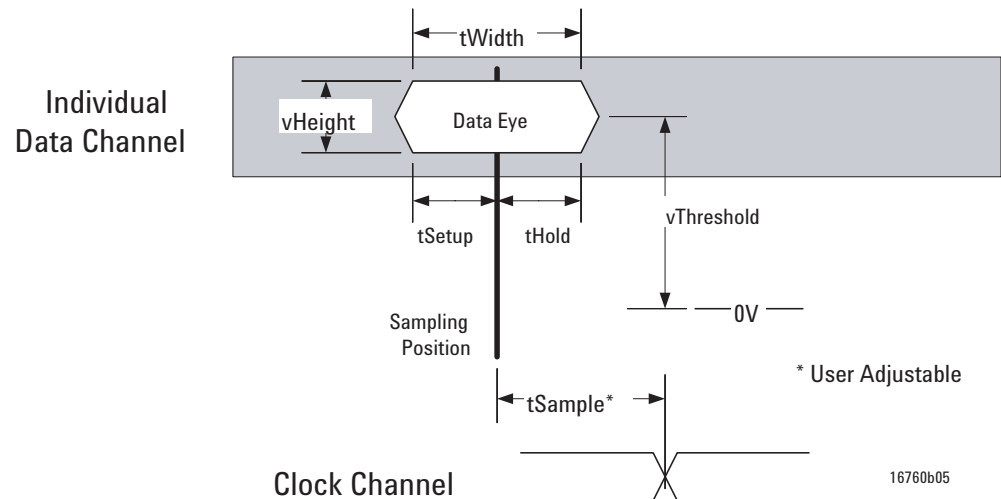

	Specifications for each input						
	Parameter	Minimum					Description/Notes
		1500 Mb/s	1250 Mb/s	800 Mb/s	400 Mb/s	200 Mb/s	
Data to Clock	t_{Width}^*	500 ps			1.25 ns		Eye width in system under test**
	t_{Setup}	250 ps			625 ps		Data setup time required before t_{Sample}
	t_{Hold}	250 ps			625 ps		Data hold time required after t_{Sample}

*Specified for an input signal ≤ 800 mV peak-to-peak voltage swing 1V/ns slew rate, using an Agilent E5378A or E5382A probe.
 **Eye width and height are specified at the probe tip. Eye width as measured by eye finder in the analyzer may be less.

Characteristics

The characteristics are not specifications, but are included as additional information.

Threshold Accuracy	± (30 mV + 1.0% of threshold setting)	
Speed/Depth/Channel Count	Full Channel	Half Channel
Maximum Conventional Timing Rate	400 MHz	800 MHz
Memory Depth	64 M	128 M
Channel Count per Card	34	17
Channel Count per Five-Card Module	170	85

Environmental Characteristics

Probes	
Maximum Input Voltage	± 40 V, CAT I, CAT I = Category I, secondary power line isolated circuits.
Auxiliary Power	
Power Through Cables	1/3 amp at +5 V maximum per cable.
Operating Environment	
Temperature	Instrument, 0 °C to 40 °C (+32 °F to 104 °F) when installed in a 16900A or 16902A mainframe. Instrument, 0 °C to 50 °C (+32 °F to 122 °F) when installed in a 16903A or 16700-series mainframe. Probe lead sets and cables, 0 °C to 65 °C (+32 °F to 149 °F).
Humidity	Instrument, probe lead sets, and cables, up to 95% relative humidity at +40 °C (+122 °F). Non-condensing.
Altitude	To 3000 m (10,000 ft).
Vibration	Operating: Random vibration 5 to 500 Hz, 10 minutes per axis, ≈0.2 g (rms). Non-operating: Random vibration 5 to 500 Hz, 10 minutes per axis, ≈2.41 g (rms); and swept sine resonant search, 5 to 500 Hz, 0.5 g (0-peak), 5 minute resonant dwell at 4 resonances per axis.
	Operating power supplied by mainframe. Indoor use only. Pollution Degree 2.

Recommended Test Equipment

Equipment Required

Equipment	Critical Specifications	Recommended Agilent Model/Part	Use
Probe Adapter	no substitute	E5378A	P, T
Probe Adapter (Qty 2)*	no substitute	E5382A	P, T
Ground Clips (Qty 10)	no substitute	16517-82105 (pkg of 20)	T
Stimulus Board	no substitute	16760-60001	T
Pulse Generator	750 MHz, 666.6 ps pulse width, < 120 ps rise time	8133A Option 003	P, T
Digitizing Oscilloscope	≥11 GHz bandwidth, < 31.8 ps rise time	54750A mainframe with 54751A plug-in module	P
Test connectors**	no substitute		P
150 ps Transition Time Converters (Qty 4)	See page 22.	Agilent or HP 15435A	P
20:1 Probes (Qty 2)		54006A	T
SMA Coax Cable (Qty 3)	≥ 18 GHz bandwidth	8120-4948	P
BNC Coax Cable	BNC (m-m), > 2 GHz bandwidth	8120-1840	P
Adapter	SMA(m)-BNC(f)	1250-1200	P

P = Performance Tests, T = Troubleshooting

*For a multcard module, one probe adapter per card is required.

**Instructions for making these test connectors are in Chapter 3.

Preparing for Use

This chapter gives you instructions for preparing the logic analyzer module for use.

Power Requirements

All power supplies required for operating the logic analyzer are supplied through the backplane connector in the mainframe.

Operating Environment

The operating environment is listed on page 12. Note the non-condensing humidity limitation. Condensation within the instrument can cause poor operation or malfunction. Provide protection against internal condensation.

The logic analyzer module will operate at all specifications within the temperature and humidity range given on page 12. However, reliability is enhanced when operating the module within the following ranges:

Temperature: +20 °C to +35 °C (+68 °F to +95 °F)

Humidity: 20% to 80% non-condensing

Storage

Store or ship the logic analyzer in environments within the following limits:

- Temperature: -40 °C to +75 °C (-40 °F to +167 °F).
- Humidity: Up to 90% at 65 °C.
- Altitude: Up to 15,300 meters (50,000 feet).

Protect the module from temperature extremes which cause condensation on the instrument.

To inspect the module

1 Inspect the shipping container for damage.

If the shipping container or cushioning material is damaged, keep them until you have checked the contents of the shipment and checked the instrument mechanically and electrically.

2 Check the supplied accessories.

One or more of the accessories listed on page 10 are required to operate the 16760A logic analyzer module.

3 Inspect the product for physical damage.

Check the module and the supplied accessories for obvious physical or mechanical defects. If you find any defects, contact your nearest Agilent Technologies Sales Office. Arrangements for repair or replacement are made, at Agilent Technologies' option, without waiting for a claim settlement.

To configure and install the module

Instructions for configuring and installing the module into the mainframe can be found in the installation guide for the mainframe.

If you don't have the installation guide for your mainframe, you can find the latest version on the Internet at www.agilent.com.

For example: to find the installation guide for a 16700B mainframe, go to www.agilent.com and enter "16700B installation guide" in the quick search box. Then, scroll down to "Manuals, Guides & Notifications" to find the *16700B-Series Logic Analysis Systems Installation Guide*.

To test the module

The logic analyzer module does not require an operational accuracy calibration or adjustment. After installing the module, you can test and use the module.

- If you require a test to verify the specifications, see "Testing Performance" on page 19.
- If you require a test to verify correct module operation using software self-tests, see "To run the self-tests" on page 126.
- If the module does not operate correctly, see "Troubleshooting" on page 121.

To clean the module

- With the mainframe turned off and unplugged, use a cloth moistened with a mixture of mild detergent and water to clean the rear panel.
- Do not attempt to clean the module circuit board.

Testing Performance

This chapter tells you how to test the performance of the logic analyzer against the specifications.

Overview

To ensure the logic analyzer is operating as specified, two kinds of tests are made:

- Software (self) tests.
- Manual performance tests.

The logic analyzer is considered performance-verified if all of the software tests and manual performance tests have passed. The procedures in this chapter indicate what constitutes a “Pass” status for each of the tests.

16900-Series vs. 16700-Series Mainframes

The module can be tested in either a 16900-series or 16700-series logic analysis system mainframe. In either case, the SMA/Flying Lead Test Connectors, the equipment required, and setup of the test equipment will be the same, except that the logic analyzer setup will differ. The general instructions for performance test begin on page 23 with instructions for assembling the test connectors. Instructions specific to testing the module in a 16900-series mainframe begin on page 40. Instructions specific to testing the module in a 16700-series mainframe begin on page 79.

Manual Performance Test Strategy

Only specified parameters are tested. The specifications for the 16760A logic analyzer define a *minimum data eye width* and a *minimum clock interval* at which data can be acquired.

Acquisition Mode:	200 Mb/s	400 Mb/s	800 Mb/s	1.25 Gb/s	1.5 Gb/s
Minimum clock interval, active edge to active edge	5 ns	2.5 ns	1.25 ns	800 ps	667 ps
Minimum data pulse width	1.5 ns	1.5 ns	750 ps	750 ps	600 ps

The manual performance tests verify that the logic analyzer meets these specifications.

At each of the five acquisition modes, you test the minimum data eye width at the minimum clock interval, thereby testing both specifications at once.

The minimum clock interval is specified from active clock edge to active clock edge. All tests are performed while clocking data into the logic analyzer on both rising and falling edges of the clock (double edge clock), so the pulse generator test frequency is set to half of the acquisition speed.

Eye finder is used to adjust the sampling position on every channel. *Eye finder* must be used to achieve minimum data eye width.

The test conditions defined in the manual test procedure ensure that the specified parameter is as good as or better than specification. No attempt is made to determine performance which is better than specification. Not all channels of the logic analyzer will be tested; rather a sample of channels is tested. A calibration laboratory may choose to elaborate on these tests and test all channels at their discretion.

One-Card Module

To perform a complete test on a one-card module, start at the beginning of the chapter and follow the test procedure.

Multi-Card Module

To perform a complete test on a multi-card module:

- Perform the software (self) tests (page 27) with the cards connected.
- Then, remove the multi-card module from the mainframe and configure each card as a one-card module. Install the one-card modules into the mainframe and perform the manual tests on each card.
- When the manual tests are complete, remove the one-card modules, reconfigure them into their original multi-card module configuration, reinstall it into the mainframe and perform the software (self) tests again.

For removal instructions see Chapter 6, “Replacing Assemblies,” beginning on page 171. For installation and configuration instructions see Chapter 2, “Preparing for Use,” beginning on page 15.

Test Interval

Test the performance of the module against specifications at two-year intervals.

Test Record Description

A performance test record for recording the results of each procedure is located at the end of this chapter.

Test Equipment Required

Each procedure lists the recommended test equipment. You can use equipment that satisfies the specifications given. However, the procedures are based on using the recommended model or part number.

The following equipment is required for the performance test procedure.

Equipment	Qty	Critical Specification	Recommended Model/Part
Pulse Generator	1	≥ 765 MHz, two channels, differential outputs, 150-180 ps rise/fall time (if faster, use transition time converters).	Agilent or HP 8133A option 003
150 ps Transition Time Converter	4	Required if pulse generator's rise time is less than 150 ps. (Pulse generator conditions: Voffset = 1V, $\Delta V = 250$ mV.) Required for 8133A opt. 003.	Agilent or HP 15435A
Oscilloscope	1	bandwidth ≥ 1.5 GHz, sampling rate ≥ 8 GSa/s	Agilent or HP 54845A/B or similar
SMA Coax Cable	2	> 18 GHz bandwidth	Agilent or HP 8120-4948
Flying Lead Probe Set	2	no substitute	Agilent E5382A
Male BNC to Female SMA adapters	2		Cambridge Products CP-AD507 (ref: www.cambridgeproducts.com)
SMA/Flying Lead test connectors, (f) SMA to (f) SMA to Flying Lead Probe	4	no substitute	See "Assemble the SMA/Flying Lead Test Connectors" on page 23

Instrument Warm-Up

Before testing the performance of the module, warm-up the instrument and the test equipment for 30 minutes.

Assemble the SMA/Flying Lead Test Connectors

The SMA/Flying Lead test connectors provide a high-bandwidth connection between the logic analyzer and the test equipment. The following procedure explains how to fabricate the four required test connectors.

Materials Required

Material	Qty	Critical Specification	Recommended Model/Part
SMA Board Mount Connector	8		Johnson 142-0701-801 (ref: www.johnsoncomponents.com)
Pin Strip Header	1 (will be separated)	.100" X .100" Pin Strip Header, right angle, pin length .230", two rows, .120" solder tails	3M 2380-5121TN or similar 2- row with 0.1" pin spacing
SMA 50 ohm terminators	2	Minimum bandwidth 2 GHz	Johnson 142-0801-866 50 ohm Dummy Load Plug
SMA m-m adapter	4		Johnson 142-0901-811 SMA Plug to Plug or similar

1 Prepare the pin strip header:

- a** Cut or cleanly break a 2 x 2 section from the pin strip.

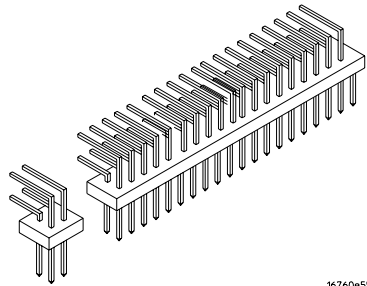

16760e55

- b** Trim about 1.5 mm from the pin strip inner leads and straighten them so that they touch the outer leads.

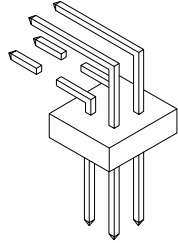

16760e56

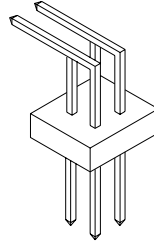

16760e57

- c** Trim about 2.5 mm from the outer leads.

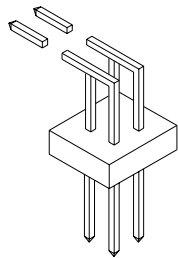

16760e58

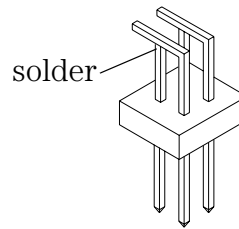

16760e59

- d** Using a very small amount of solder, tack each inner lead to each outer lead at the point where they are touching.

2 Solder the pin strip to the SMA board mount connector:

- a** Solder the leads on the left side of the pin strip to the center conductor of the SMA connector as shown in the diagram below.
- b** Solder the leads on the right side of the pin strip to the inside of the SMA connector's frame as shown in the diagram below. Use a small amount of solder.

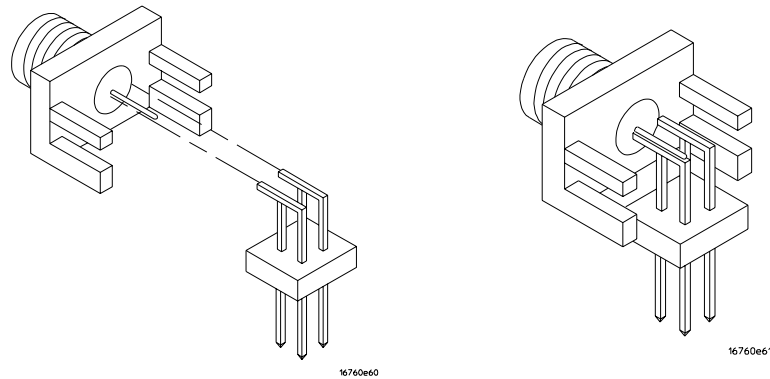

3 Attach the second SMA board mount connector:

- a** Re-heat the solder connection made in the previous step, and attach the second SMA connector, as shown in the diagram below. Note that the second SMA connector is upside-down, compared to the first. Add a little solder to make a good connection.
- b** Solder the center conductor of the second SMA connector to the center conductor of the first SMA connector and the leads on the left side of the pin strip.

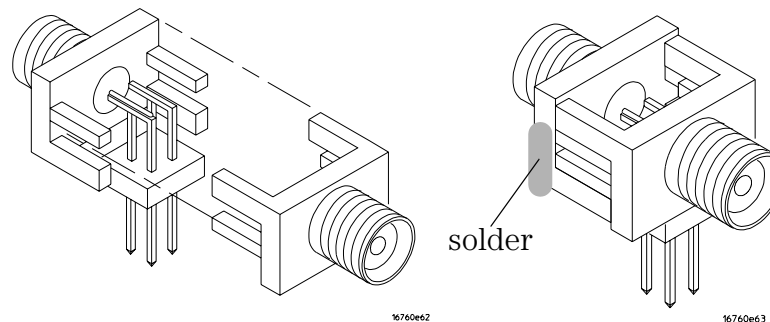

- c** Rotate the assembly 180 degrees and solder the two SMA board mount connector frames together.

4 Check your work:

- a** Ensure that the following four points have continuity between them:
The two pins on the left side of the pin strip, and the center conductors of each SMA connector.
- b** Ensure that there is continuity between each of the two pins on the right side of the pin strip, and the SMA connector frames.
- c** Ensure that there is NO continuity between the SMA connector center conductor and the SMA connector frame (ground).

5 Finish creating the test connectors:

- a** Attach an SMA m-m adapter to one end of each of the four SMA/Flying Lead test connectors.

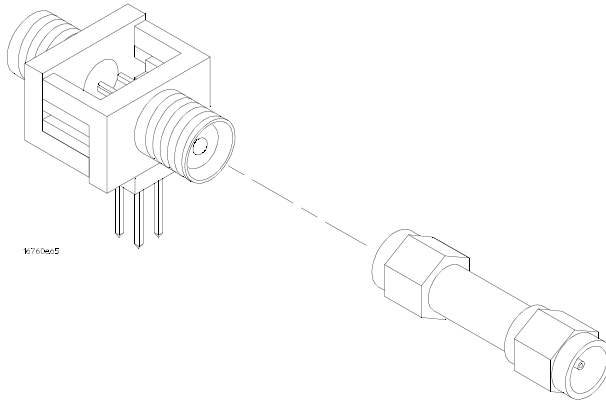

- b** Attach a 50 ohm terminator to the other end of just two of the SMA/Flying Lead test connectors.

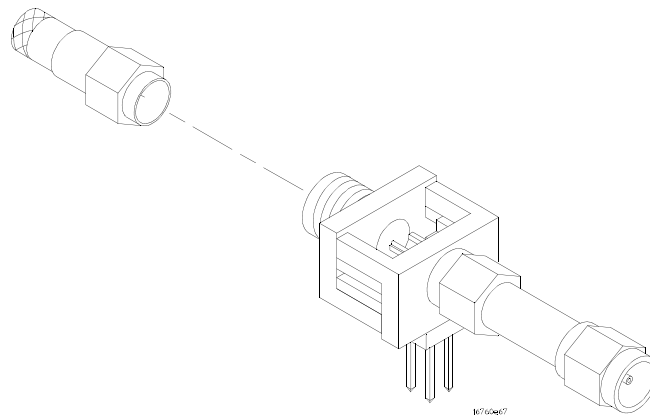

Run the Software (Self) Tests

On a 16900-Series Mainframe

Use the following instructions to test the module using a 16900-series mainframe. If you are using a 16700-series mainframe, use the instructions beginning on page 29.

- 1** Record the 16760A logic analyzer's model and serial number in the Performance Test Record (see page 118). Record your work order number (if applicable) and today's date.
- 2** Record the test equipment information in the "Test Equipment Used" section of the Performance Test Record.
- 3** Turn on the logic analysis system.

NOTE:

Before testing the performance of the module, warm-up the logic analyzer and the test equipment for 30 minutes.

- a** Connect the keyboard and monitor to the rear panel of the logic analysis mainframe (16900A only).
- b** Connect the mouse to the rear panel of the mainframe.
- c** Plug in the power cord to the power connector on the rear panel of the mainframe.
- d** Turn on the main power switch on the mainframe front panel.

While the logic analysis system is booting, observe the boot dialogue for the following:

- Ensure all of the installed memory is recognized.
 - Any error messages.
 - Interrupt of the boot process with or without error message.
- 4** During initialization, check for any failures.

If an error or an interrupt occurs, refer to the *Agilent Technologies 16900A-Series Logic Analysis System Service Guide* for troubleshooting information.

- 5 Do a self-test on the 16900-series logic analysis system.
 - a When the logic analysis system has finished booting, the Waveform window appears. Choose “Help>Self-Test...” from the main menu. The Analysis System Self Tests dialog appears.

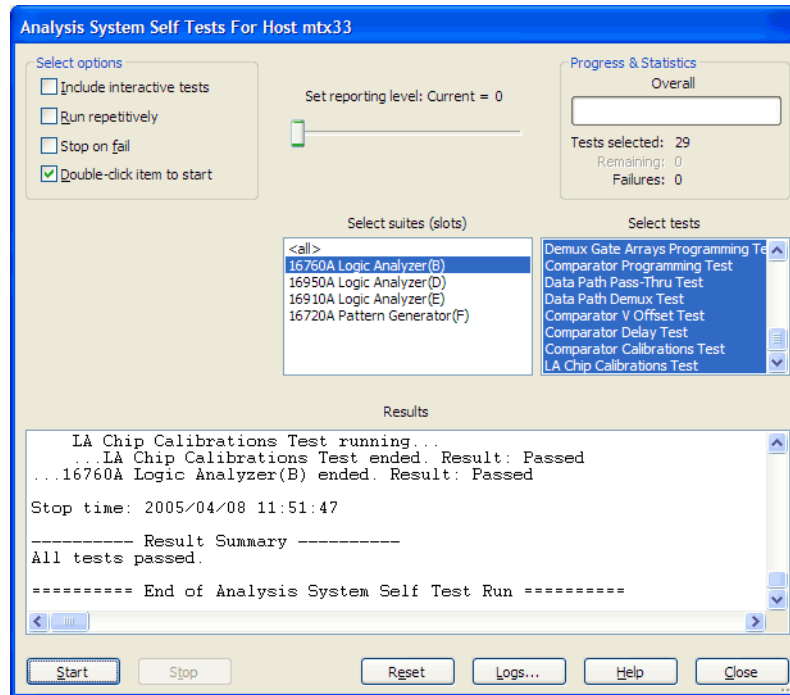

- b In the Select Suite(s) list, select <all>. This will cause <all> to be selected in the Select Test(s) list.
- c Click “Start”. This will perform a complete system self-test.

The progress of the self tests is displayed in the Progress & Statistics area of the window.
- d When the self-tests are complete, check the Results window to ensure that the Result Summary says that all tests passed. If all tests did not pass, refer to “Troubleshooting” on page 121.
- e Click “Close” to close the Analysis System Self Tests dialog.
- f If all module self-tests pass, then record “PASS” in the “Logic Analysis System Self-Tests” section of the Performance Test Record (page 118).

On a 16700-Series Mainframe

- 1** Turn on the logic analysis system.
 - a** Connect the keyboard and monitor to the rear panel of the logic analysis mainframe (16700B only).
 - b** Connect the mouse to the rear panel of the mainframe.
 - c** Plug in the power cord to the power connector on the rear panel of the mainframe.
 - d** Turn on the main power switch on the mainframe front panel.

While the logic analysis system is booting, observe the boot dialogue for the following:

- ensure all of the installed memory is recognized
- any error messages
- interrupt of the boot process with or without error message

A complete transcript of the boot dialogue is in the Agilent Technologies 16700B-series Logic Analysis System Service Guide, Chapter 8, "Theory of Operation."

- 2** During initialization, check for any failures.

If an error or an interrupt occurs, refer to the Agilent Technologies 16700B-series Logic Analysis System Service Guide, Chapter 5, "Troubleshooting." Note that if an Agilent 16760A module is temporarily installed in a mainframe only to test the performance of the module, then the mainframe may report that the module will require an operational accuracy calibration. This is expected, and step 4 in this procedure will clear this error message.

- 3** Do a self-test on the logic analysis system.

- a** When the logic analysis system has finished booting and the System window appears (that is, a session has started), click on the System Administration icon.
- b** Under the Admin tab, click on Self-Test... in the query pop-up, select Yes to exit the current session.

The Self-Test closes the current session because the test algorithms leave the system in an unknown state. Re-launching the session at the end of the self-test will ensure the system is properly initialized.

- c** In the Self-Test window select Test All.

When the tests are finished, the Status will change to Passed or Failed. You can find detailed information about the test results in the Status Message field of the Self-Test window.

Some system CPU board tests may return a status of Untested because they require user action. Procedures to do these tests are found in the Agilent Technologies 16700B-series Logic Analysis System Service Guide. For the purposes of testing the Agilent 16760A module performance, running untested system CPU board tests are not required. If these tests are not done, the Agilent 16760A performance test is not affected.

- d** When the self-tests are complete, select Quit to exit the test menu.
 - e** Record a PASS in the Performance Test Record if all module self-tests pass.
- 4** Set up the logic analysis system.
- a** In the Session Manager window, select "Start Session" to re-launch a logic analysis session.
 - b** In the Logic Analysis System window, select the module icon, then select Setup and Trigger. A Setup and Trigger window will appear.
 - c** In the Setup and Trigger window, click on the Calibration tab. Follow the instructions under the Calibration tab to perform an operational accuracy calibration on the Agilent 16760A module.

Repeat the above step for each single-card Agilent 16760A module installed in the mainframe that is being tested. If any calibration status returns "failed," then the Agilent 16760A module requires repair. If the calibration status returns "passed" for both pods, then record a PASS in the performance test record at the end of this chapter.

- d** Proceed to the next section when the operational accuracy calibration is complete.

Initialize the Test Equipment for Manual Tests

- 1** Turn on the required test equipment. Let all of the test equipment and the logic analyzer warm up for 30 minutes before beginning any test.
- 2** Set up the pulse generator.
 - a** Set the frequency of the pulse generator. We will test in the 200 Mb/s mode first.

The logic analyzer will be tested using a double-edge clock. The test frequency is half the test clock rate because data is acquired on both the rising edge and the falling edge of the clock. Set the frequency to 100 MHz plus the frequency uncertainty of the pulse generator, plus a test margin of 1%.

For example, if you are using an 8133A pulse generator, the frequency accuracy is $\pm 1\%$ of setting. Use a test margin of 1%. Set the frequency to 100 MHz plus 2% (102 MHz).

- b** Set the rest of the pulse generator parameters to the values shown in the following table.

Pulse Generator Setup

Timebase	Pulse Channel 2	Trigger	Pulse Channel 1
Mode: Int	Mode: Pulse \div 1	Disable (LED on)	Mode: Square
Freq: was set in previous step.	Delay: (not available in pulse mode)		Delay: 0 ps
	Width: Initially set to 1.5 ns. Change later (on page 38).		Width: (not available in square mode)
	Ampl: 0.25 V		Ampl: 0.25 V
	Offs: 1.0 V		Offs: 1.0 V
	Output: Enable (LED off)		Output: Enable (LED off)
	Comp: Normal (LED off)		Comp: Normal (LED off)
	Limit: Off (LED off)		Limit: Off (LED off)
	Output: Enable (LED off)		Output: Enable (LED off)

3 Set up the oscilloscope.

a Set up the oscilloscope according to the following tables.

Oscilloscope Setup

Setup: Channel 1	Setup: Ch. 1 Probe	Setup: Channel 2	Setup: Ch. 2 Probe
On	Attenuation: 1.00:1	On	Attenuation: 1.00:1
Scale: 50 mV/div	Units: Volts	Scale: 50 mV/div	Units: Volts
Offset: 1 V	Attenuation Units: Ratio	Offset: 1 V	Attenuation Units: Ratio
Coupling: DC	External Gain: (n/a)	Coupling: DC	External Gain: (n/a)
Input: 50 ohm	Skew: (Set later. See page 37)	Input: 50 ohm	Skew: 0.0 seconds
	External Offset: (n/a)		External Offset: (n/a)

Setup: Channel 3	Setup: Channel 4
Off	Off

Setup: Horizontal	Setup: Trigger	Setup: Acquisition	Setup: Display
Scale: 500 ps/div	Mode: Edge	Sampling Mode: Equiv. Time	Waveforms: Connect dots
Position: 800 ps	Source: Channel 1	Memory Depth: Automatic	Persistence: Minimum
Reference: Center	Level: 1.00 V	Averaging: Enabled	Grid: On (and set intensity)
Delayed: not selected	Edge: Rising Edge	# of Averages: 4	Backlight Saver: as preferred
	Sweep: Auto		

Measure: Markers
Mode: Manual placement
All else: (n/a)

Connect the Test Equipment for Manual Tests

Connect the 16760A Logic Analyzer Pod to the 8133A Pulse Generator

- 1** Connect a Transition Time Converter (if required—see page 22) to each of the four outputs of the 8133A pulse generator: Channel 1 OUTPUT, Channel 1 $\overline{\text{OUTPUT}}$, Channel 2 OUTPUT, Channel 2 $\overline{\text{OUTPUT}}$.
- 2** Connect the two SMA/Flying Lead test connectors (see “Assemble the SMA/Flying Lead Test Connectors” on page 23) *with* 50 ohm terminators to the Transition Time Converters at the 8133A pulse generator Channel 1 OUTPUT and Channel 1 $\overline{\text{OUTPUT}}$. (If Transition Time Converters are not required, connect the SMA/Flying Lead test connectors directly to the pulse generator outputs.)
- 3** Connect the two SMA/Flying Lead test connectors *without* 50 ohm terminators to the Transition Time Converters at the 8133A pulse generator Channel 2 OUTPUT and Channel 2 $\overline{\text{OUTPUT}}$. (If Transition Time Converters are not required, connect the SMA/Flying Lead test connectors directly to the pulse generator outputs.)
- 4** Connect an E5382A Flying Lead Probe Set to Pod 1 of the 16760A logic analyzer.

- 5 Connect the E5382A Flying Lead Probe Set's CLK lead to the pin strip of the SMA/Flying Lead connector at the 8133A pulse generator's Channel 1 OUTPUT.

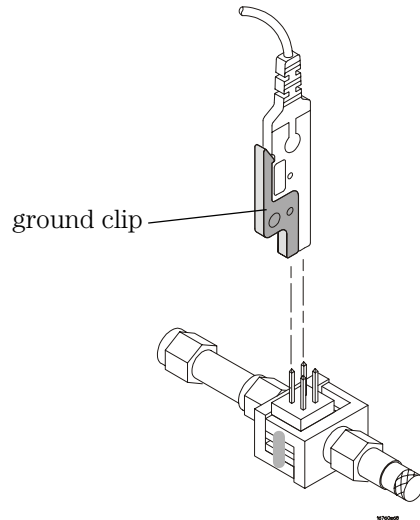

NOTE:

Be sure to use the black ground clip (supplied with the E5382A Flying Lead Probe Set) and orient the leads so that the black clip is connected to one of the SMA/Flying Lead connector's ground pins!

- 6 Connect the E5382A Flying Lead Probe Set's $\overline{\text{CLK}}$ lead to the SMA/Flying Lead connector at the 8133A pulse generator's Channel 1 $\overline{\text{OUTPUT}}$. Again, be sure to use the black ground clip and orient the leads so that the black clip is connected to ground.
- 7 Connect the E5382A Flying Lead Probe Set's bits 6 and 14 to the SMA/Flying Lead test connector's pin strip connector at the 8133A pulse generator's Channel 2 OUTPUT.
- 8 Connect the E5382A Flying Lead Probe Set's bits 2 and 10 to the SMA/Flying Lead test connector's pin strip connector at the 8133A pulse generator's Channel 2 $\overline{\text{OUTPUT}}$.

Connect the 8133A Pulse Generator Output to the 54845A Oscilloscope

- 1** Attach Male BNC to Female SMA adapters to Channels 1 and 2 on the 54845A oscilloscope.
- 2** Attach one end of an SMA cable to the Male BNC to Female SMA adapter on Channel 1 of the oscilloscope.
- 3** Attach the other end of the SMA cable to the SMA/Flying Lead connector at the Channel 2 OUTPUT of the 8133A pulse generator.
- 4** Attach one end of the other SMA cable to the Male BNC to Female SMA adapter on Channel 2 of the oscilloscope.
- 5** Attach the other end of the SMA cable to the SMA/Flying Lead connector at the Channel 2 OUTPUT of the 8133A pulse generator.

Set Up the Test Equipment for Manual Tests

Next, verify and adjust the pulse generator's DC offset, deskew the oscilloscope, and measure and adjust the pulse width.

Verify and Adjust the 8133A Pulse Generator DC Offset

- 1 On the 54845A oscilloscope, select Measure from the menu bar at the top of the display.
- 2 Select Markers...
- 3 In the Markers Setup window set marker "Ay" to 0.875 V, and set marker "By" to 1.125 V.

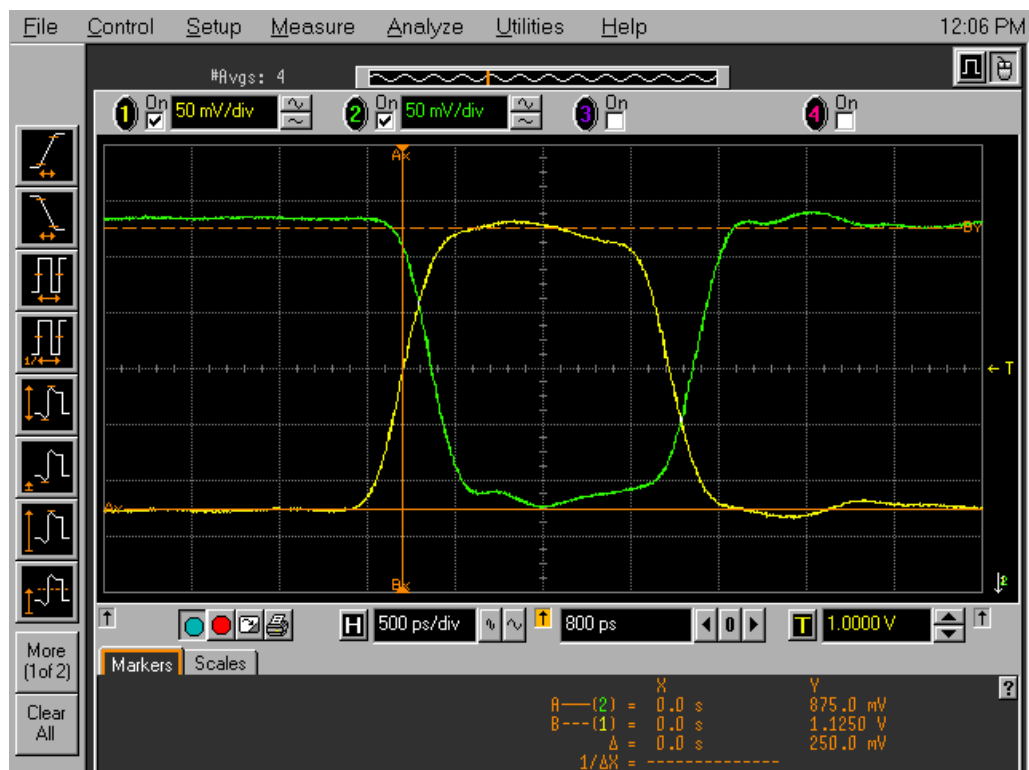

- 4 Observe the waveforms on the oscilloscope display. If they are not centered within the "Ay" and "By" markers, adjust the 8133A pulse generator's Channel 2 OFFSET until the waveforms are centered as well as possible. (The resolution of the 8133A OFFSET setting is 20 mV.)

Deskew the Oscilloscope

This procedure neutralizes any skew in the oscilloscope's waveform display.

- 1 On the 54845A oscilloscope, change the Horizontal scale from 500 ps/div to 200 ps/div. You can do this using the large knob in the Horizontal setup section of the front panel.

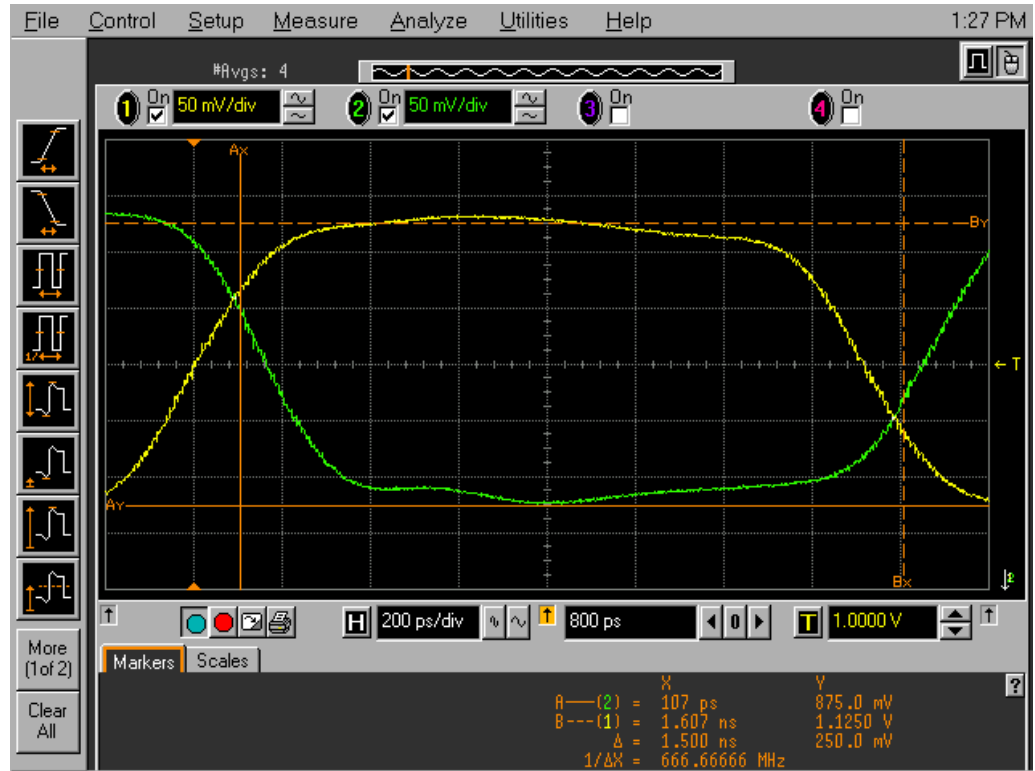

- 2 Select Setup from the menu bar at the top of the oscilloscope display.
- 3 Select Channel 1.
- 4 Select Probes.

NOTE:

If the Probes dialog obscures the waveform display, select Utilities, User Preferences..., and in the Dialog section choose Transparent. Then position the Probes dialog so you can see the horizontal crossings of the waveforms.

- 5 Select Skew </> to deskew Channel 1 and Channel 2 signals so that both channels cross the 54845A horizontal center line at the same time, at both ends of the eye (both crossings of the horizontal center line). The horizontal center of the graticule line is at 1 volt because the vertical offset was set to 1 volt in the oscilloscope setup described on page 32.

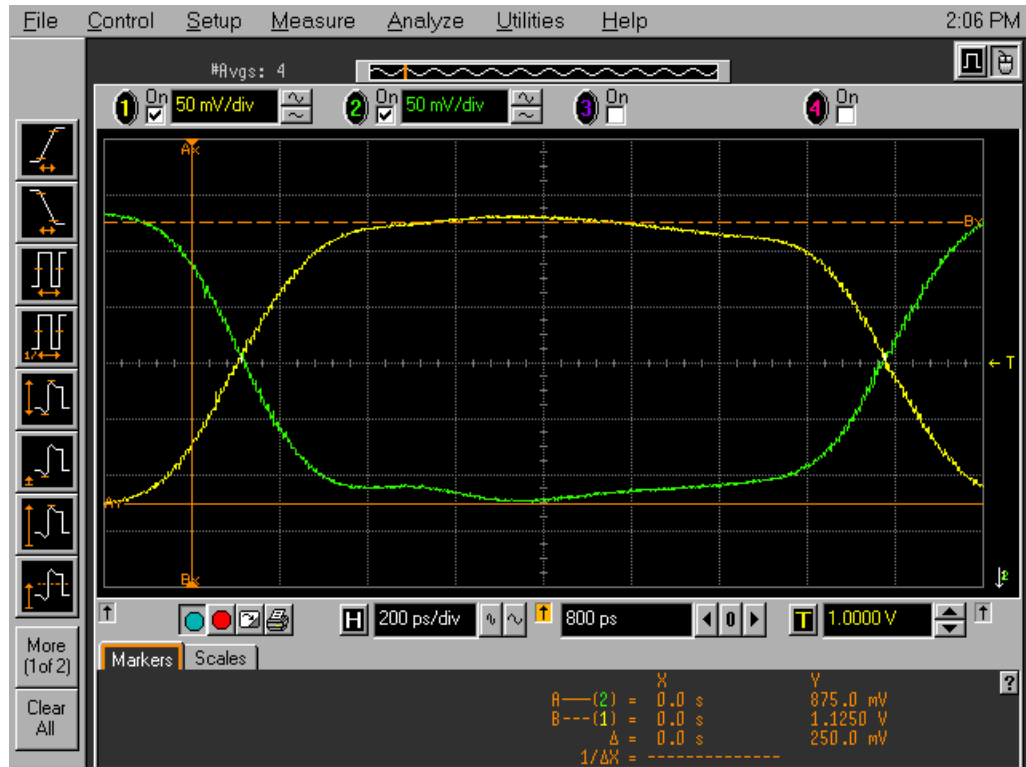

- 6 Select Close in the Probe Setup window.
- 7 Select Close in the Channel Setup window.

Adjust the Measured Pulse Width to 1.5 ns

The pulse generator's pulse width was set to 1.5 ns (in the setup on page 31). In this procedure, you will use the oscilloscope's measurement markers to measure the actual pulse width in the test setup. Then you will adjust the pulse generator so that the measured pulse width is as specified.

- 1 Observe the 54845A oscilloscope display. Change the Channel 2 pulse width of the 8133A pulse generator so that the pulse width measured at 1 volt on the oscilloscope is equal to 1.5 ns minus the measurement

uncertainty and display resolution of the oscilloscope, further reduced by 35 ps for test margin.

For example, if you are using the 54845A/B oscilloscope, the measurement uncertainty is $\pm((0.007\% * \Delta t) + (\text{full scale}/2x \text{ memory depth}) + 30 \text{ ps}) \cong \pm 30 \text{ ps}$. Add 5 ps for display resolution. Add 35 ps test margin.

$$1500 \text{ ps} - 30.15 \text{ ps} - 5 \text{ ps} - 35 \text{ ps} = 1430 \text{ ps}$$

Therefore, set the pulse width as measured on the 54845A/B oscilloscope to 1430 ps.

- 2 On the oscilloscope, move the Ax and Bx markers to the crossing points of the pulse and the horizontal center line. Read the pulse width at the bottom of the oscilloscope display. It is displayed as “ Δ =”.

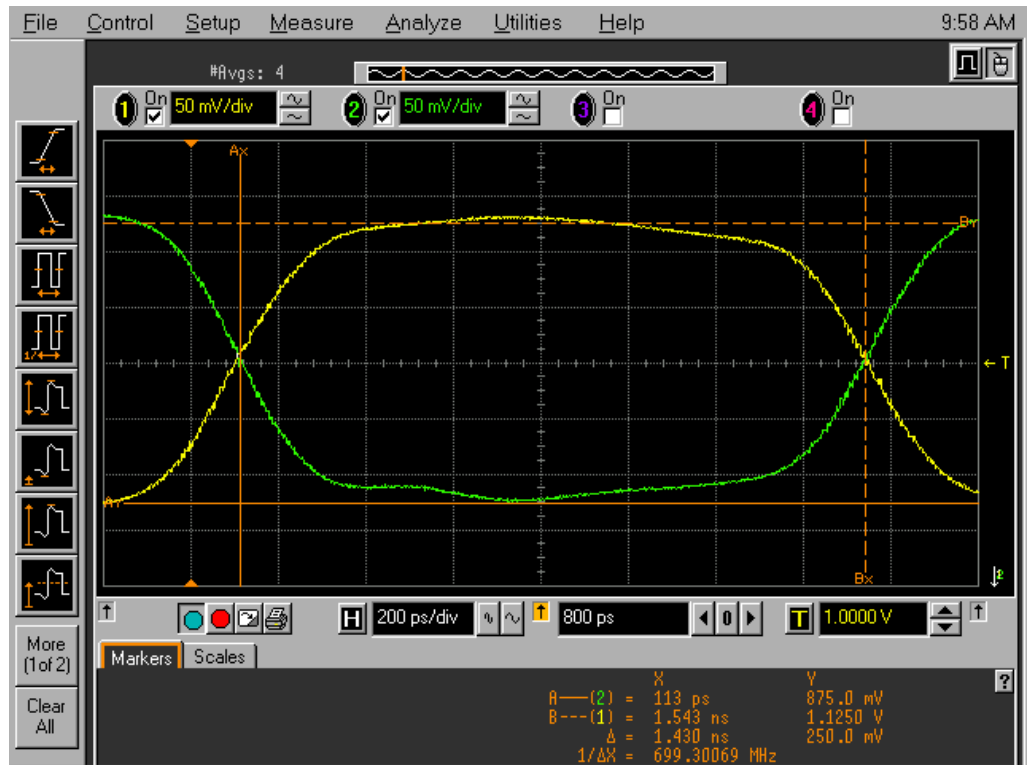



Manual Test Procedure, 16900-Series Mainframe

The steps that follow include pass/fail criteria.

Test Pod 1 in 200 Mb/s Mode

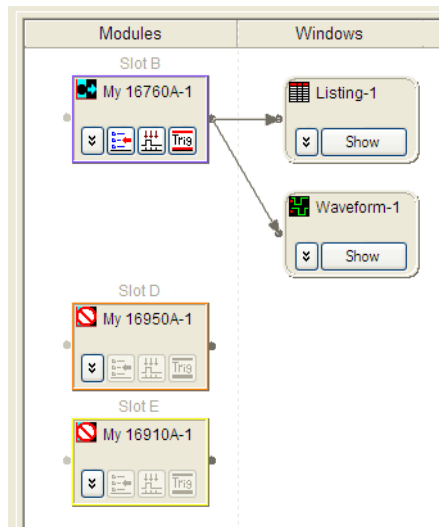
- 1** Configure the logic analyzer:
 - a** In the *Agilent Logic Analyzer* application, choose “File>New” to put the logic analysis system into its initial state.
 - b** Disable all logic analyzers other than the analyzer under test.
 - i** Select the Overview tab at the bottom of the main window.
 - ii** Click on each unused logic analyzer and select disable. Only the logic analyzer to be tested should remain enabled.



- c** Set up threshold voltages and a bus name for the probed signals.
 - i** Click the  Bus/Signal Setup icon.
 - ii** In the Analyzer Setup dialog, click the Threshold button for Pod 1.

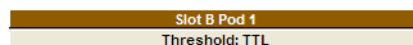

NOTE:

The E5382A probe must be connected to the logic analyzer pod as described on page 33.

- iii In the Threshold Settings dialog, set the threshold value for Pod 1 of the 16760A logic analyzer to “1 V”. Also, check “Apply setting to all pods” to properly set the threshold voltage for Pod 2, and uncheck “Apply settings to clock bits” (because the clock input threshold will be set to “differential” in a later step).

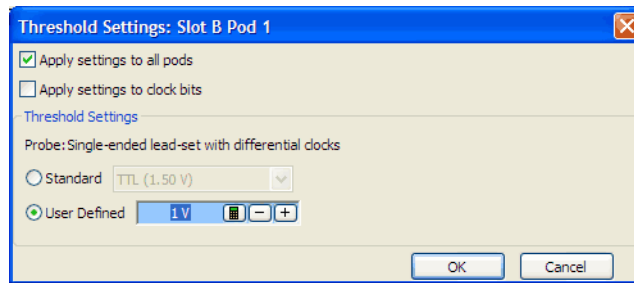

- iv Click “OK” to close the Threshold Settings dialog. Now, in the Analyzer Setup dialog, the activity indicators for Pod 1 show activity on the channels that are connected to the pulse generator.
- v Un-assign all channels (hint: you can do this quickly by clicking on the left-most check mark and dragging to the right across all of the other check marks — if you have a model 16902A or 16903A logic analysis system mainframe you can touch the touchscreen and drag across with your finger) and re-assign Pod 1 channels 2, 6, 10, and 14 to the “My Bus 1” bus.

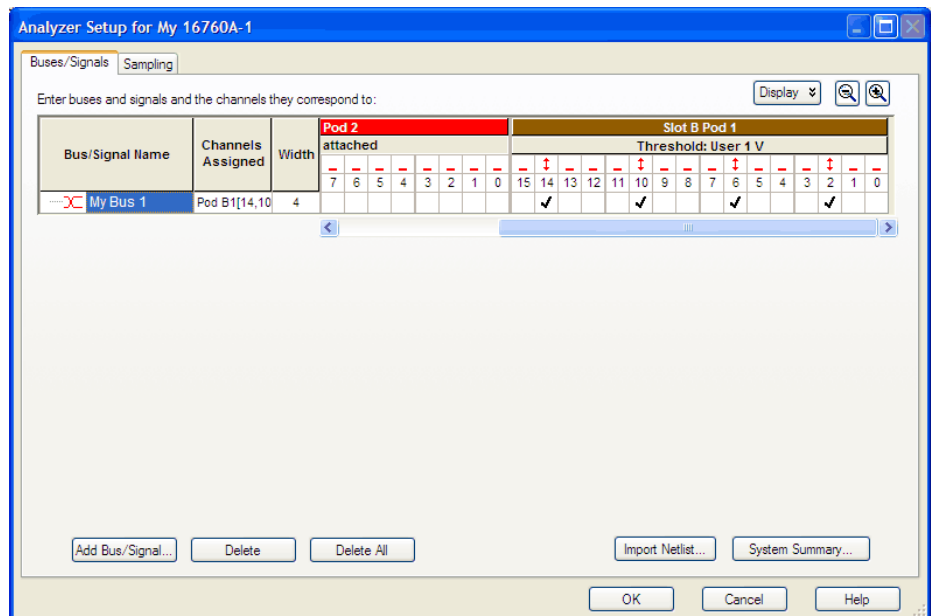

- vi Drag the scroll bar all the way to the left and click the “Clock” threshold

button.



- vii** In the Threshold Settings - Clocks dialog, click the threshold button associated with the Pod 1 clock.

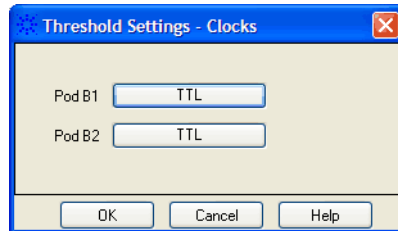

- viii** In the Threshold Settings for Pod 1 dialog, select “Differential”.

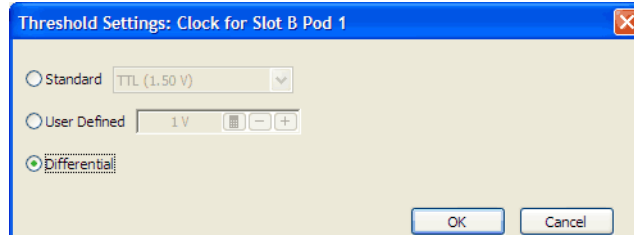

- ix** Click “OK” to close the Threshold Settings dialogs. Now, in the Analyzer Setup dialog, the activity indicator for the Pod 1 clock shows activity.
- d** Set the sampling mode:
 - i** Click the “Sampling” tab in the Analyzer Setup dialog.
 - ii** Select the “State - Synchronous Sampling” Acquisition mode.
 - iii** Set the Trigger Position to “100% poststore”.
 - iv** Set the Acquisition Depth to “128K”.
 - v** Select the “200 Mb/s” Sampling Option.

- vi Select “Both Edges” for Pod1 Clk1.

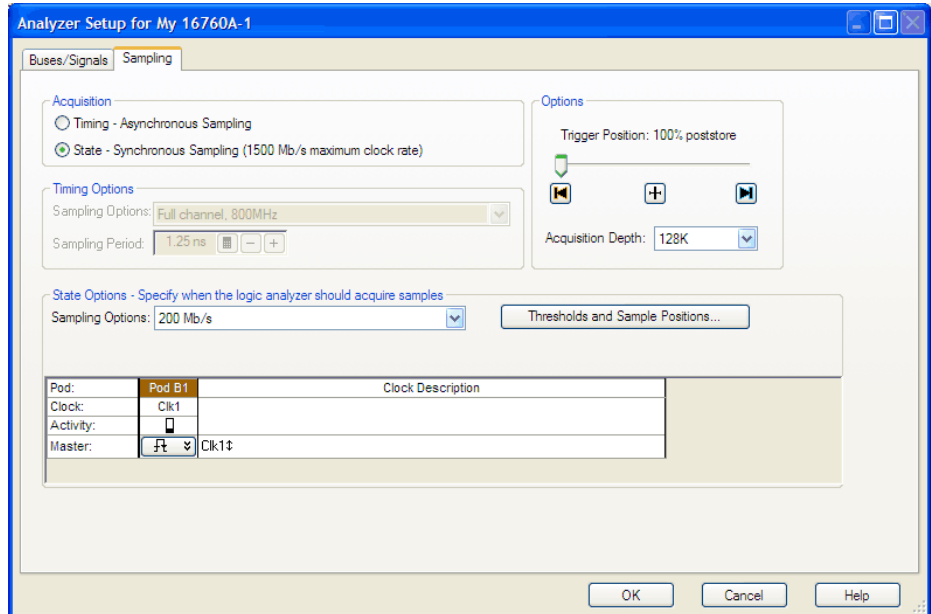

2 Adjust sampling positions using *eye finder*:

- a In the Analyzer Setup dialog’s Sampling tab, click “Thresholds and Sample Positions...”.
- b In the Thresholds and Sample Positions dialog, expand the “My Bus 1” bus name so you can see the individual signals in the bus.
- c If the blue bars in the *eye finder* display are not vertically aligned:
 - i Grab the right-most blue bar in the “My Bus 1” row with the mouse pointer and move it all the way to the left and release the mouse button. This will vertically align all of the blue bars.
- d Using the mouse pointer, grab the blue bar for “My Bus 1” and move it to the recommended starting position of 0.6 ns. All of the blue bars will follow.
- e Click “Run” (the green button in the lower left-hand corner of the dialog).
- f Ensure that an eye appears for each bit near the recommended starting position. Depending on your test setup, the eye position may vary. Any skew between channel 1 and channel 2 of your pulse generator will cause the eye position to shift to the left or right in the *eye finder* display. A shift of up to 0.5 ns should be considered normal. The important point is that your *eye finder* display should look similar to

the picture below (although it may be shifted left or right), and *eye finder* must be able to place the blue bars in the narrow eye.

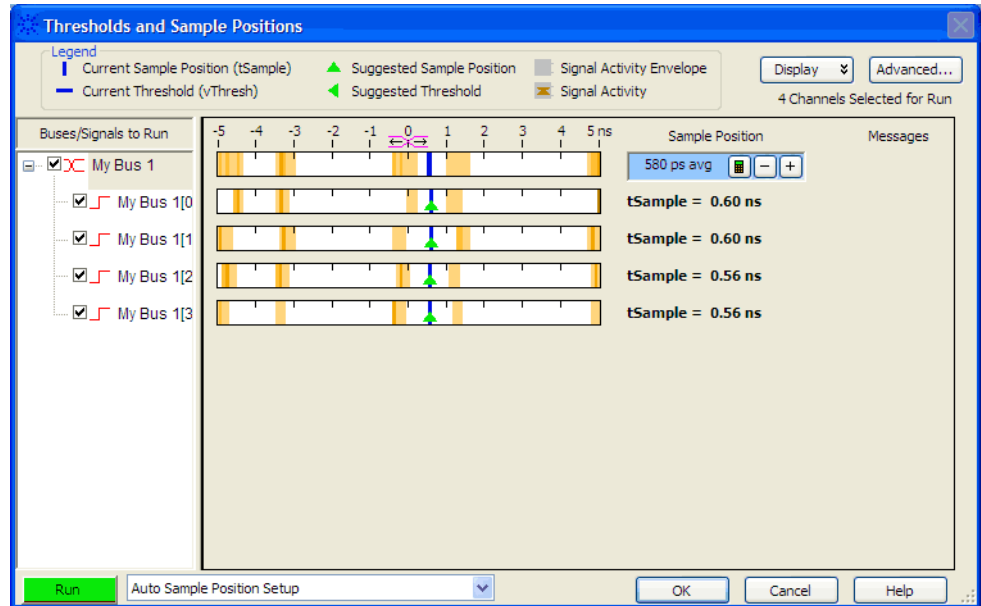

g Re-align any stray channels if necessary. See page 45.

Re-Aligning a Stray Channel

If the blue bar for a particular bit does not appear in its eye near the recommended starting position, you need to re-align the sampling position of the stray channel. In the following example, the sampling position of one channel (My Bus 1[2]) must be re-aligned with the sampling position of the other channels. (The following example shows the analyzer in the 1500 Mb/s mode.)

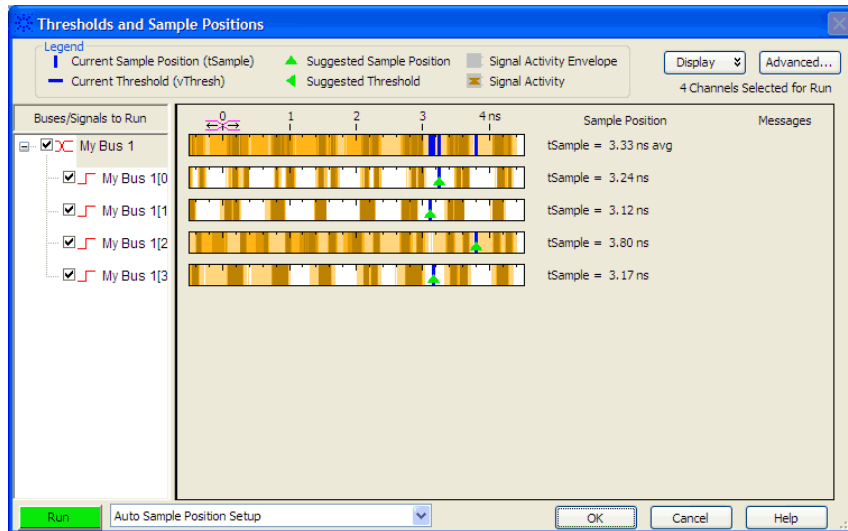

Using the mouse, drag the sample position (blue line) of a stray channel so that it is in the same eye as the other channels (drag channel My Bus 1[2] in the above example). The suggested position from *eye finder* (green triangle) will also move to the new eye. Do this for all remaining stray channels.

Click "Run". *Eye finder* will recalculate the new sample positions based on the sample position changes. The following example shows all sampling positions aligned and in the correct eye (with the analyzer in the 1500 Mb/s mode).

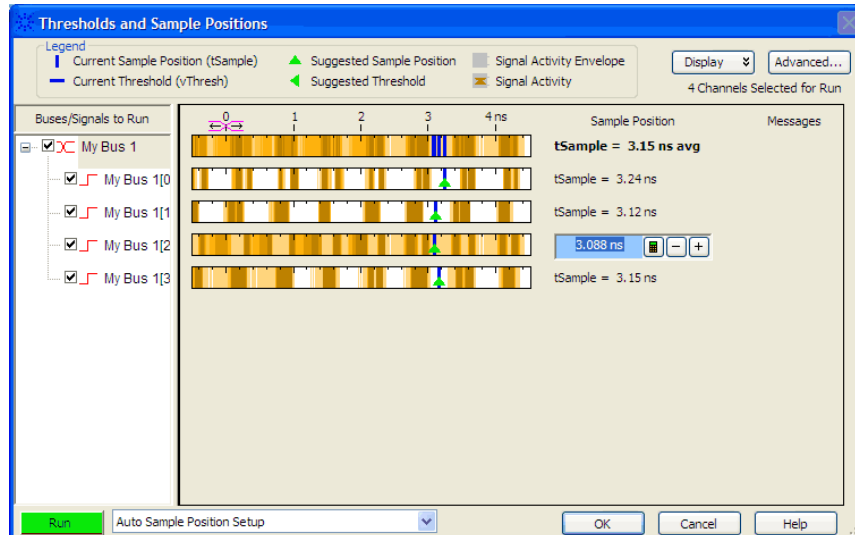

- 3 Determine PASS/FAIL (1 of 2 tests):
 - a PASS/FAIL: If an eye exists near the recommended starting position for every bit, and *eye finder* places a blue bar in the eye for each bit, then the logic analyzer passes this portion of the test.
 - b If an eye does not exist near the recommended starting position for every bit or *eye finder* cannot place the blue bar in the eye, then the logic analyzer fails the test. Record the failure in the test record (shown on page 118).
- 4 In the Listing window, set up the logic analyzer to trigger on the value “A”, and click the  Run icon.

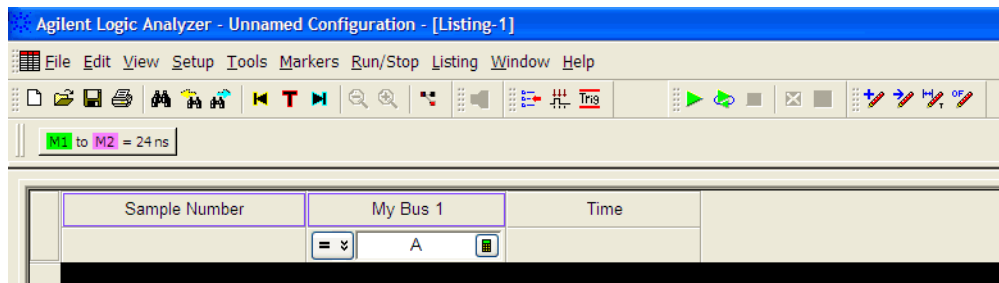

- 5 Set up a marker to search for the appropriate number of A's or 5's:
 - a From the main menu, choose “Marker>New...”.

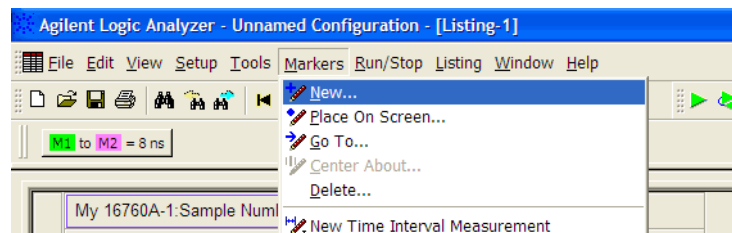

- b In the New Marker dialog's Position box, select “Value” and from “Beginning Of Data”.

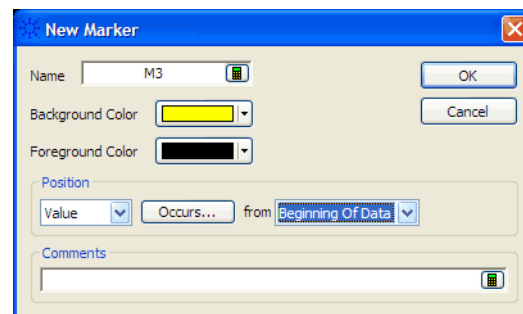

- c Click “Occurs...”.
- d In the Value dialog, enter “131072” occurrences (the decimal equivalent of 128K samples) of the bus value “A” or “5” when “Present”.

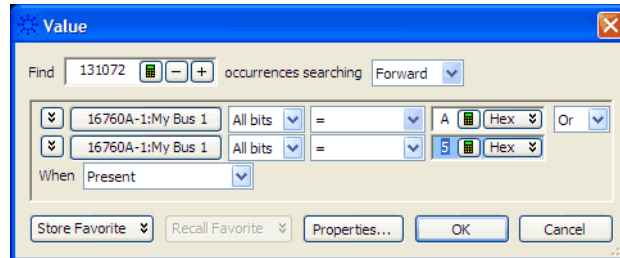

- e Click “Properties...”.
- f In the Value Properties dialog, select when value “is not found”, “Stop repetitive run”.

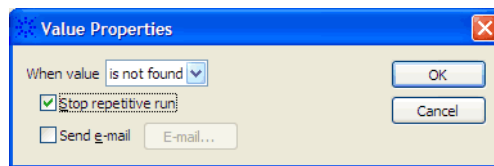

- g Click “OK” to close the Value Properties, Value, and New Marker dialogs.
- 6** Determine PASS/FAIL (2 of 2 tests):

Pass/Fail Point: The Listing window is set up to search for the appropriate number of A's and 5's in the acquisition. If the logic analyzer does not detect the correct number of A's and 5's, an error window will appear.

- a Click the  Run Repetitive icon. Let the logic analyzer run for about one minute.

The logic analyzer acquires data, and the Listing window will continuously updates. Each time the logic analyzer runs, you see the value marker searching for the specified number of occurrences.

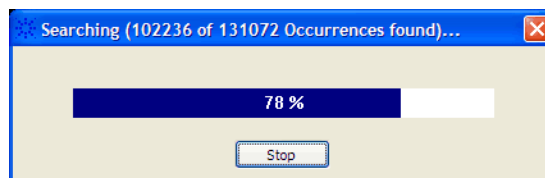

If the “can’t find occurrence” dialog appears, the logic analyzer fails the test.

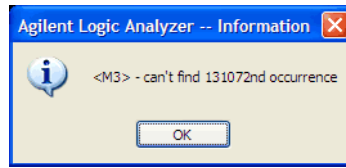

Check your test setup. If the failure is not the result of a problem with the test setup, record the failure in the appropriate place on the Performance Test Record.

NOTE:

Be sure that the black ground clip is making good contact with the ground pin on the test connector.

b After about one minute, click the  Stop icon to stop the acquisition.

If the “can’t find occurrence” dialog does not appear, the logic analyzer passes the test. Record “Pass” in the appropriate place on the Performance Test Record.

NOTE:

As a point of curiosity, you may want to determine the absolute minimum pulse width and/or absolute maximum frequency at which data can be acquired. The “Performance Test Record” on page 118 does not include places for recording these values because the Performance Verification procedure only verifies that the logic analyzer meets specifications. Determination of additional parameters is not required, but may be performed at the discretion of the calibration laboratory.

On some pulse generators, the signal outputs may become slightly unstable for a very short period of time when the signal parameters are adjusted. Adjusting the pulse generator while the logic analyzer is running can cause a false failure.

If the error message is displayed immediately after making an adjustment to the pulse generator, click “OK” to close the error dialog, and re-run the logic analyzer.

7 Test the complement of the bits:

- a** On the 8133A pulse generator, in the PULSE setup for CHANNEL 2, select COMP.
- b** Note that the signal on the oscilloscope has moved. Change the oscilloscope’s horizontal position to -600 ps (or as required) to center the measured pulse on the oscilloscope display.
- c** Verify the DC offset and adjust it if necessary. See page 36.
- d** Deskew the oscilloscope if necessary. See page 37.

- e Adjust the oscilloscope's measurement markers to measure the pulse width. Set the markers so that $\Delta=1430$ ps (this assumes you are using the 8133A pulse generator and the Infiniium oscilloscope). Adjust the pulse generator so that the pulse width is 1430 ps as measured by the markers. See page 38 for details.

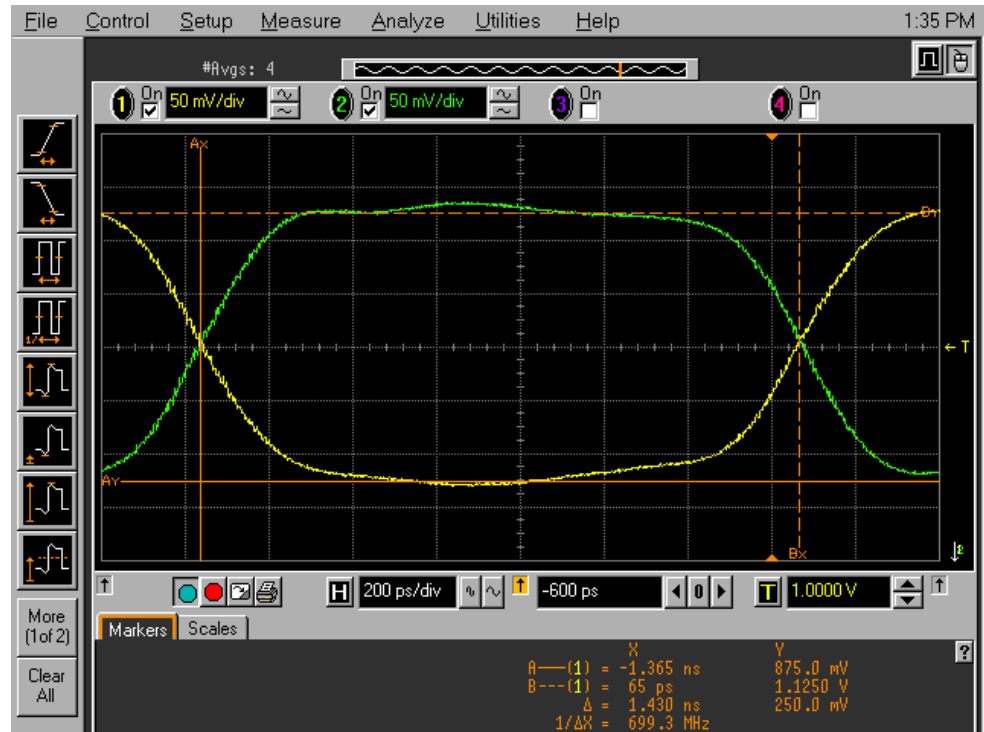

- f Adjust the sampling positions (run *eye finder*). See page 43.
- g Determine pass or fail (1 of 2 tests). See page 46.
- h Click the  Run Repetitive icon.
- i Determine pass or fail (2 of 2 tests). See page 47.

Test Pod 2 in 200 Mb/s Mode

- 1** Change test equipment connections:
 - a** Leave the first E5382A Flying Lead Probe Set connected to Pod 1 of the logic analyzer. Remove the Pod 1 flying leads 2, 6, 10, and 14 from the SMA/Flying Lead test connectors. Do not remove the flying leads that are connected to CLK and $\overline{\text{CLK}}$.
 - b** Connect the second E5382A Flying Lead Probe Set to Pod 2 of the logic analyzer.
 - c** Connect the Pod 2 E5382A Flying Lead Probe Set's bits 6 and 14 to the SMA/Flying Lead test connector's pin strip connector at the 8133A pulse generator's Channel 2 OUTPUT.
 - d** Connect the Pod 2 E5382A Flying Lead Probe Set's bits 2 and 10 to the SMA/Flying Lead test connector's pin strip connector at the 8133A pulse generator's Channel 2 OUTPUT.
- 2** On the 8133A pulse generator, in the PULSE setup for CHANNEL 2, press the COMP button to return the outputs to normal.
- 3** Note that the signal on the oscilloscope has moved. Change the oscilloscope's horizontal position to 800 ps (or as required) to center the measured pulse on the oscilloscope display.
- 4** Verify the DC offset and adjust it if necessary. See page 36.
- 5** Deskew the oscilloscope if necessary. See page 37.
- 6** Re-adjust the pulse width from the pulse generator as measured on the oscilloscope to 1.5 ns. See page 38.
- 7** Re-assign bits to "My Bus 1":
 - a** Click the  Bus/Signal Setup icon.

- b** In the Analyzer Setup dialog's Buses/Signals tab, re-assign the "My Bus 1" bus name to bits 2, 6, 10, and 14 of Pod 2.

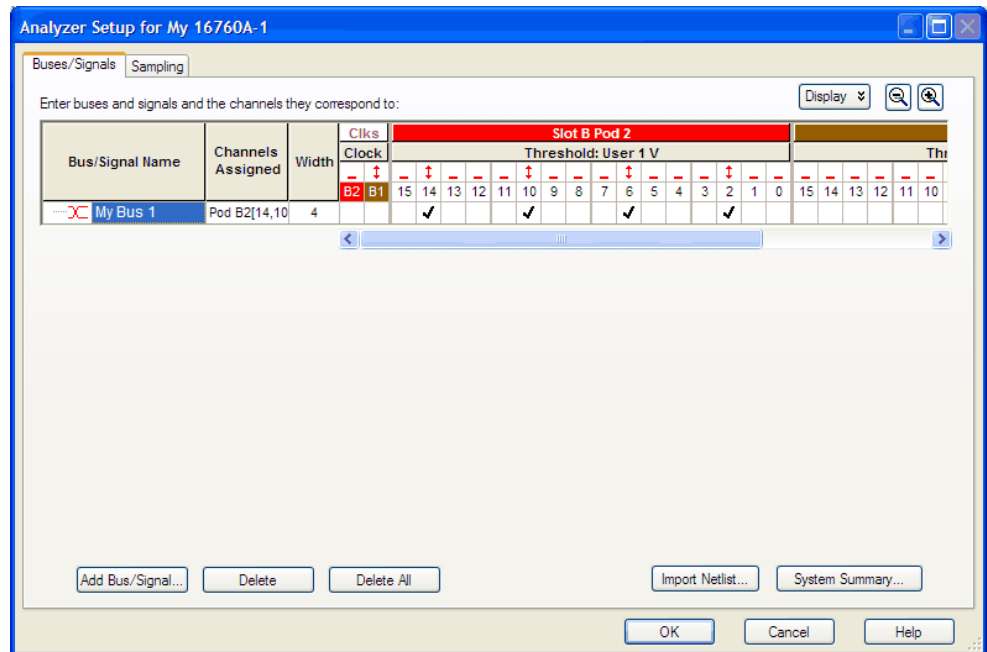

(The threshold voltages for Pod 2 and the Pod 1 clock were previously set up to "1 V" and "differential", respectively.)

- c** Click "OK" to close the Analyzer Setup dialog.
- 8** Adjust the sampling positions using *eye finder*. Be sure to expand "My Bus 1" and use the recommended starting position noted on page 43. Re-align any stray channels if necessary. See page 45.
- 9** Determine pass or fail (1 of 2 tests). See page 46.
- 10** Click the  Run Repetitive icon.
- 11** Determine pass or fail (2 of 2 tests). See page 47.
- 12** Test the complement of the bits. See page 48.

Test Pod 1 in 400 Mb/s mode

- 1** Change test equipment connections:
 - a** Disconnect the Pod 2 E5382A Flying Lead Probe Set's bits 2, 6, 10, and 14 from the SMA/Flying Lead test connectors' pin strip connectors.

The original E5382A Flying Lead Probe Set should still be connected to Pod 1. The Pod 1 clock will be used for all tests.
 - b** Connect the Pod 1 E5382A Flying Lead Probe Set's bits 6 and 14 to the SMA/Flying Lead test connector's pin strip connector at the 8133A pulse generator's Channel 2 OUTPUT.
 - c** Connect the Pod 1 E5382A Flying Lead Probe Set's bits 2 and 10 to the SMA/Flying Lead test connector's pin strip connector at the 8133A pulse generator's Channel 2 OUTPUT.
- 2** On the 8133A pulse generator, in the PULSE setup for CHANNEL 2, press the COMP button to return the outputs to normal.
- 3** Note that the signal on the oscilloscope has moved. Change the oscilloscope's horizontal position to 800 ps (or as required) to center the measured pulse on the oscilloscope display.
- 4** Verify the DC offset and adjust it if necessary. See page 36.
- 5** Set the frequency of the pulse generator. The logic analyzer will be tested using a double-edge clock. The test frequency is half the test clock rate because data is acquired on both the rising edge and the falling edge of the clock. Set the frequency to 200 MHz plus the frequency uncertainty of the pulse generator, plus a test margin of 1%.

For example, if you are using an 8133A pulse generator, the frequency accuracy is $\pm 1\%$ of setting. Use a test margin of 1%. Set the frequency to 200 MHz plus 2% (204 MHz).
- 6** Verify the oscilloscope Deskew and adjust if necessary. See page 37.
- 7** Adjust the measured pulse width from the pulse generator to 1.5 ns (minus the test margin) as described on page 38.
- 8** Change the sampling option:
 - a** Click the  Sampling Setup icon.
 - b** In the Analyzer Setup dialog's Sampling tab, select the "400 Mb/s" Sampling Option.

- c Click “OK” to close the Analyzer Setup dialog.
- 9 Change the logic analyzer pod assignment to use Pod 1:
 - a Choose “Setup>(logic analyzer module name)>Pod Assignment...”.

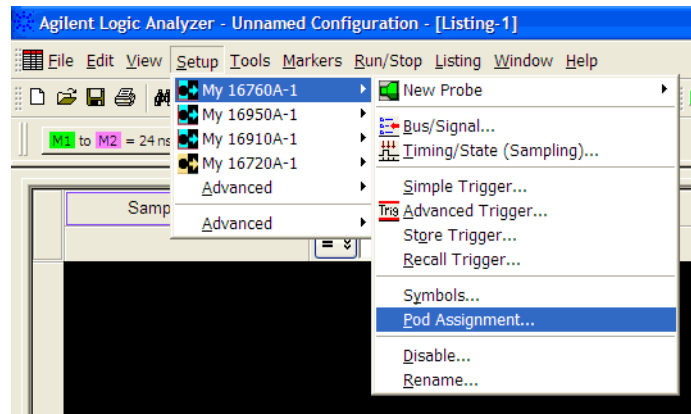

- b In the Pod Assignment dialog, select the logic analyzer module name for Pod 1 and “Reserved for time tag storage” for Pod 2.

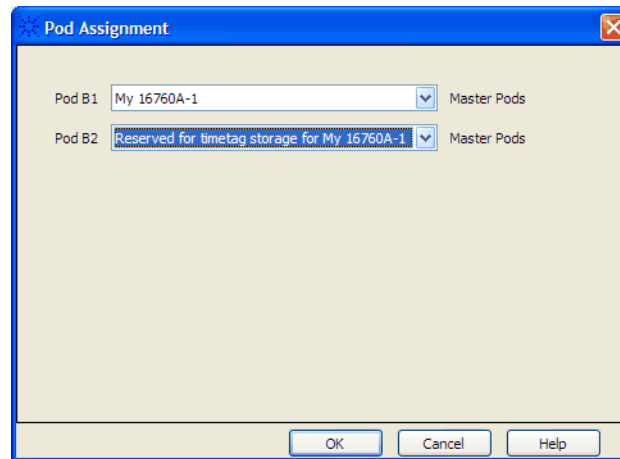

- c Click “OK” to close the Pod Assignment dialog.
- 10 Re-assign bits to “My Bus 1”:
 - a Click the  Bus/Signal Setup icon.
 - b In the Analyzer Setup dialog’s Buses/Signals tab, re-assign the “My Bus 1” bus name to bits 2, 6, 10, and 14 of Pod 1.

(The threshold voltages for Pod 1 and the Pod 1 clock were previously set up to “1 V” and “differential”, respectively.)

c Click “OK” to close the Analyzer Setup dialog.

11 Adjust sampling positions using *eye finder*:

a Click the  Sampling Setup icon.

b In the Analyzer Setup dialog’s Sampling tab, make sure “Rising Edge” is selected for Pod1 Clk1.



c Click “Thresholds and Sample Positions...”.

d In the Thresholds and Sample Positions dialog, expand the “My Bus 1” bus name so you can see the individual signals in the bus.

e Grab the blue bar for “My Bus 1” and move it to approximately 0.9 ns. All blue bars will follow.

f Click “Run” (the green button in the lower left-hand corner of the dialog).

Note the average sampling position chosen by *eye finder*: _____ns.

In the following example, the average sampling position is 0.83 ns. The position may be different based on your test setup.

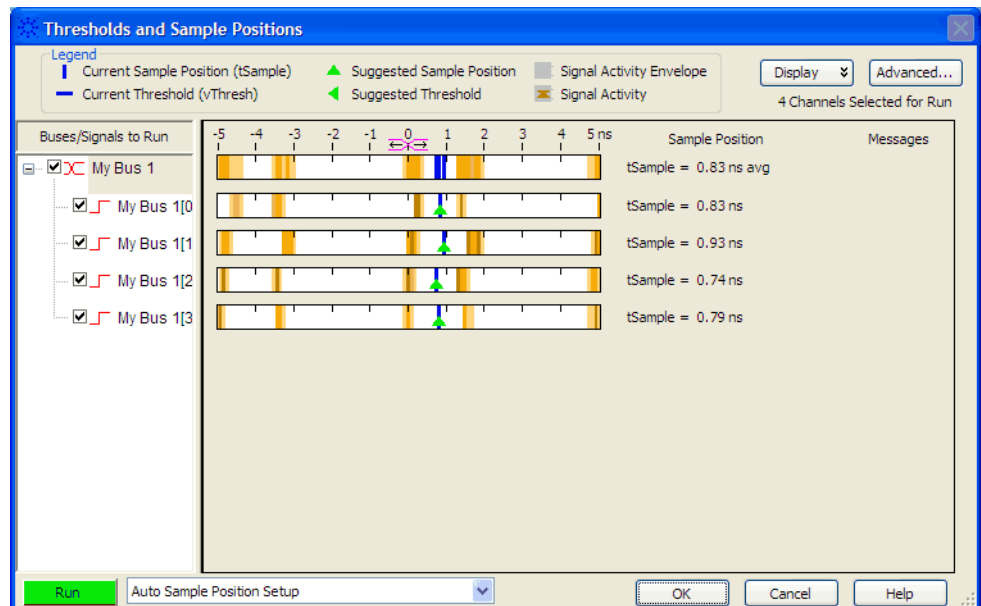

Note that in this step, you place the blue bars in the first narrow window (not the wide window) that appears to the right of zero in the *eye finder* display.

- g** Bring stray channels into alignment if necessary. See page 45.
- h** Click “OK” to close the Thresholds and Sample Positions dialog.
- i** Now, select “Both Edges” for Pod1 Clk1.



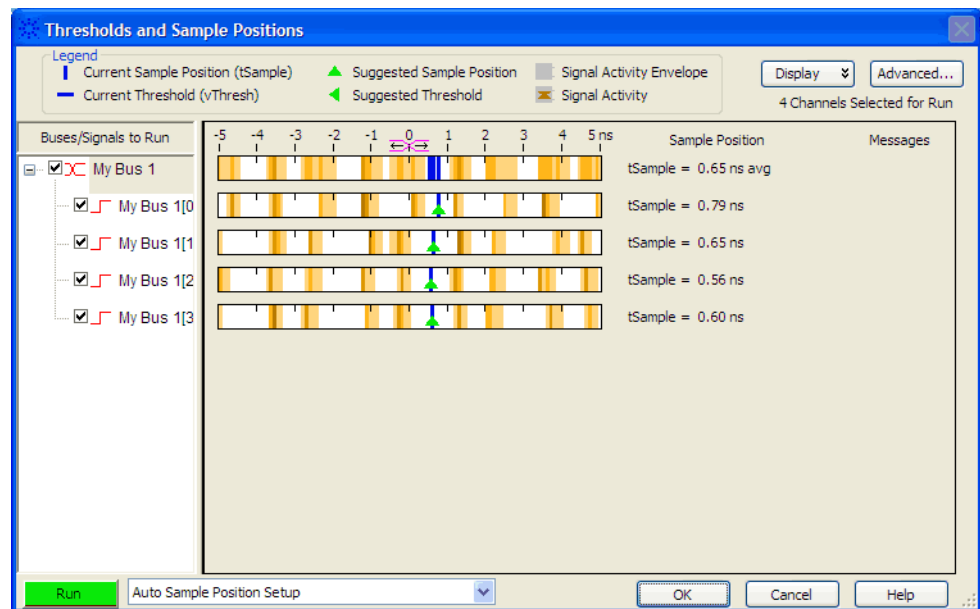

- j** Click “Thresholds and Sample Positions...”.
- k** In the Thresholds and Sample Positions dialog, align the blue bars vertically. See page 43.
- l** Grab the blue bar for “My Bus 1” and move it to the recommended starting position you noted in the prior step.
- m** Click “Run” (the green button in the lower left-hand corner of the dialog) again.

Some eyes may close, but the eyes in the sampling position you chose on page 54 should remain open.



- 12** Perform the procedure “Determine PASS/FAIL (1 of 2 tests):” on page 46.

- 13** Make sure the logic analyzer is set up for testing data acquisition:
 - a** In the Listing window, make sure the logic analyzer is set up to trigger on My Bus 1 value “A”.
 - b** Click the  Run icon.
 - c** Make sure the search marker is set up to search for 131072 occurrences of A's or 5's. See page 46.
- 14** Click the  Run Repetitive icon.
- 15** Perform the procedure “Determine PASS/FAIL (2 of 2 tests):” on page 47.
- 16** Test the complement of the bits:
 - a** On the 8133A pulse generator, in the PULSE setup for CHANNEL 2, select COMP.
 - b** Note that the signal on the oscilloscope has moved. Change the oscilloscope's horizontal position to -600 ps (or as required) to center the measured pulse on the oscilloscope display.
 - c** Verify the DC offset and adjust it if necessary. See page 36.
 - d** Deskew the oscilloscope. See page 37.
 - e** Verify that the pulse width is set to 1.5 ns. See page 38.
 - f** Run *eye finder*.
 - g** Perform the procedure “Determine PASS/FAIL (1 of 2 tests):” on page 46.
 - h** Click the  Run Repetitive icon.
 - i** Perform the procedure “Determine PASS/FAIL (2 of 2 tests):” on page 47.

Test Pod 2 in 400 Mb/s mode

- 1** Change test equipment connections:
 - a** Leave the first E5382A Flying Lead Probe Set connected to Pod 1 of the logic analyzer. Remove the Pod 1 flying leads 2, 6, 10, and 14 from the SMA/Flying Lead test connectors. Do not remove the flying leads that are connected to CLK and $\overline{\text{CLK}}$ flying leads.
 - b** Connect the Pod 2 E5382A Flying Lead Probe Set's bits 6 and 14 to the SMA/Flying Lead test connector's pin strip connector at the 8133A pulse generator's Channel 2 OUTPUT.
 - c** Connect the Pod 2 E5382A Flying Lead Probe Set's bits 2 and 10 to the SMA/Flying Lead test connector's pin strip connector at the 8133A pulse generator's Channel 2 $\overline{\text{OUTPUT}}$.
- 2** On the 8133A pulse generator, in the PULSE setup for CHANNEL 2, press the COMP button to return the outputs to normal.
- 3** Note that the signal on the oscilloscope has moved. Change the oscilloscope's horizontal position to 800 ps (or as required) to center the measured pulse on the oscilloscope display.
- 4** Verify the DC offset and adjust it if necessary. See page 36.
- 5** Deskew the oscilloscope if necessary. See page 37.
- 6** Adjust the measured pulse width from the pulse generator to 1.5 ns (minus the test margin) as described on page 38.

7 Change the logic analyzer pod assignment to use Pod 2:

- a** Choose “Setup>(logic analyzer module name)>Pod Assignment...”.

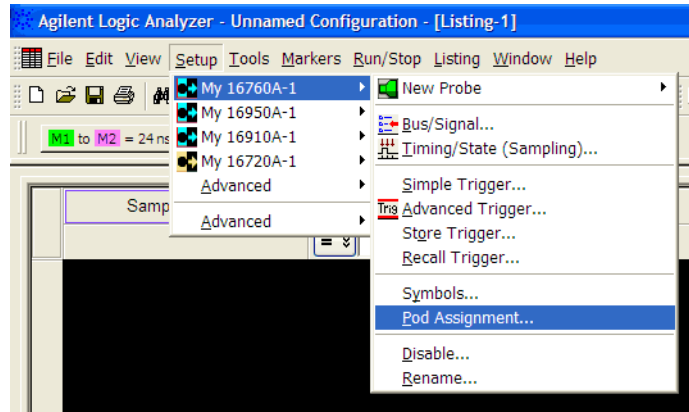

- b** In the Pod Assignment dialog, select “Reserved for time tag storage” for Pod 1 and the logic analyzer module name for Pod 2.

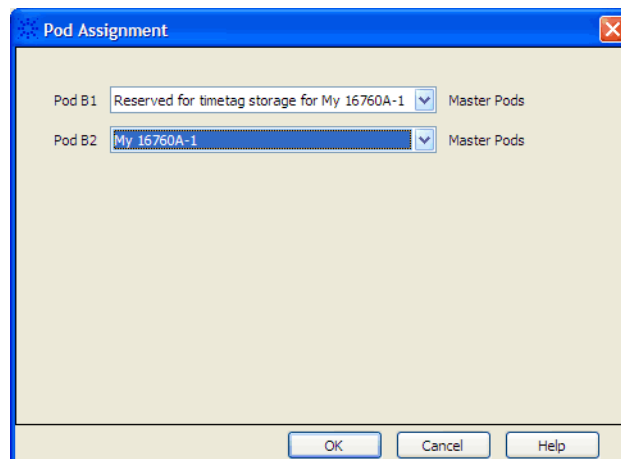



- c** Click “OK” to close the Pod Assignment dialog.

8 Re-assign bits to “My Bus 1”:

- a** Click the  Bus/Signal Setup icon.
- b** In the Analyzer Setup dialog’s Buses/Signals tab, re-assign the “My Bus 1” bus name to bits 2, 6, 10, and 14 of Pod 2.

(The threshold voltages for Pod 2 and the Pod 1 clock were previously set up to “1 V” and “differential”, respectively.)

- c** Click “OK” to close the Analyzer Setup dialog.

- 9 Adjust the sampling positions using *eye finder*. Be sure to expand “My Bus 1”. Use the starting position you noted on page 54. Re-align any stray channels if necessary. See page 45.
 - 10 Determine pass or fail (1 of 2 tests). See page 46.
 - 11 Make sure the logic analyzer is set up for testing data acquisition:
 - a In the Listing window, make sure the logic analyzer is set up to trigger on My Bus 1 value “A”.
 - b Click the  Run icon.
 - c Make sure the search marker is set up to search for 131071 occurrences of A's or 5's. See page 46.
 - 12 Click the  Run Repetitive icon.
 - 13 Determine pass or fail (2 of 2 tests). See page 47.
 - 14 Test the complement of the bits on Pod 2. You can use the procedure “Test the complement of the bits:” on page 56 as a guideline.
-

Test Pod 1 in 800 Mb/s mode

- 1 Change test equipment connections:
 - a Disconnect the Pod 2 E5382A Flying Lead Probe Set's bits 2, 6, 10, and 14 from the SMA/Flying Lead test connectors' pin strip connectors.

The original E5382A Flying Lead Probe Set should still be connected to Pod 1. The Pod 1 clock will be used for all tests.
 - b Connect the Pod 1 E5382A Flying Lead Probe Set's bits 6 and 14 to the SMA/Flying Lead test connector's pin strip connector at the 8133A pulse generator's Channel 2 OUTPUT.
 - c Connect the Pod 1 E5382A Flying Lead Probe Set's bits 2 and 10 to the SMA/Flying Lead test connector's pin strip connector at the 8133A pulse generator's Channel 2 OUTPUT.
 - 2 On the 8133A pulse generator, in the PULSE setup for CHANNEL 2, press the COMP button to return the outputs to normal.
 - 3 Note that the signal on the oscilloscope has moved. Change the oscilloscope's horizontal position to 800 ps (or as required) to center the measured pulse on the oscilloscope display.
-

- 4 Verify the DC offset and adjust it if necessary. See page 36.
- 5 Set the frequency of the pulse generator. The logic analyzer will be tested using a double-edge clock. The test frequency is half the test clock rate because data is acquired on both the rising edge and the falling edge of the clock. Set the frequency to 400 MHz plus the frequency uncertainty of the pulse generator, plus a test margin of 1%.

For example, if you are using an 8133A pulse generator, the frequency accuracy is $\pm 1\%$ of setting. Use a test margin of 1%. Set the frequency to 400 MHz plus 2% (408 MHz).

- 6 Verify the oscilloscope Deskew and adjust if necessary. See page 37.
- 7 Adjust the measured pulse width to 750 ps:

In this procedure, you will use the oscilloscope's measurement markers to measure the actual pulse width in the test setup. Then you will adjust the pulse generator so that the measured pulse width is as specified.

- a Observe the 54845A oscilloscope display. Change the Channel 2 pulse width of the 8133A pulse generator so that the pulse width measured at 1 volt on the oscilloscope is equal to 750 ps minus the measurement uncertainty and display resolution of the oscilloscope, further reduced by 35 ps for test margin.

For example, if you are using the 54845A/B oscilloscope, the measurement uncertainty is $\pm((0.007\% * \Delta t) + (\text{full scale}/2x \text{ memory depth}) + 30 \text{ ps}) \cong \pm 30 \text{ ps}$. Add 5 ps for display resolution. Add 35 ps test margin.



$$750 \text{ ps} - 30 \text{ ps} - 5 \text{ ps} - 35 \text{ ps} = 680 \text{ ps}$$

Therefore, set the pulse width as measured on the 54845A/B oscilloscope to 680 ps.

- b In the oscilloscope horizontal setup, change the position to 450 ps. Change the horizontal scale to 100 ps/div. This will make it easier for you to set the pulse width accurately.

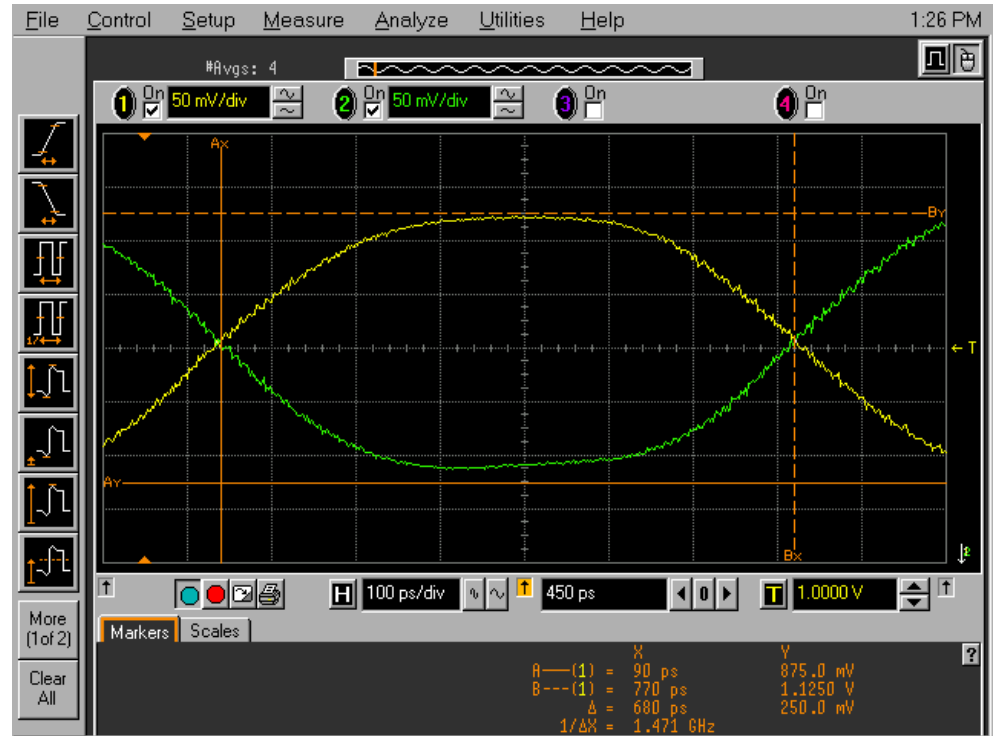
- c On the oscilloscope, move the Ax and Bx markers to the crossing points of the pulse and the horizontal center line. Read the pulse width at the bottom of the oscilloscope display. It is displayed as “Δ=”.



- 8 Change the sampling option:
 - a Click the  Sampling Setup icon.
 - b In the Analyzer Setup dialog's Sampling tab, select the “800 Mb/s” Sampling Option.
 - c Make sure the Clock Mode is “Periodic”.
 - d Click “OK” to close the Analyzer Setup dialog.
- 9 Change the logic analyzer pod assignment to use Pod 1. See page 53.
- 10 Re-assign bits to “My Bus 1”:
 - a Click the  Bus/Signal Setup icon.
 - b In the Analyzer Setup dialog's Buses/Signals tab, re-assign the “My Bus 1” bus name to bits 2, 6, 10, and 14 of Pod 1.

(The threshold voltages for Pod 1 and the Pod 1 clock were previously set up to “1 V” and “differential”, respectively.)

c Click “OK” to close the Analyzer Setup dialog.

11 Adjust sampling positions using *eye finder*:

a Click the  Sampling Setup icon.

b In the Analyzer Setup dialog’s Sampling tab, make sure “Rising Edge” is selected for Pod1 Clk1.



c Click “Thresholds and Sample Positions...”.

d In the Thresholds and Sample Positions dialog, expand the “My Bus 1” bus name so you can see the individual signals in the bus.

e Grab the blue bar for “My Bus 1” and move it to approximately -2.1 ns. All blue bars will follow.

f Click “Run” (the green button in the lower left-hand corner of the dialog).

Note the average sampling position chosen by *eye finder*: _____ns.

In the following example, the average sampling position is -2.14 ns. The position may be different based on your test setup.

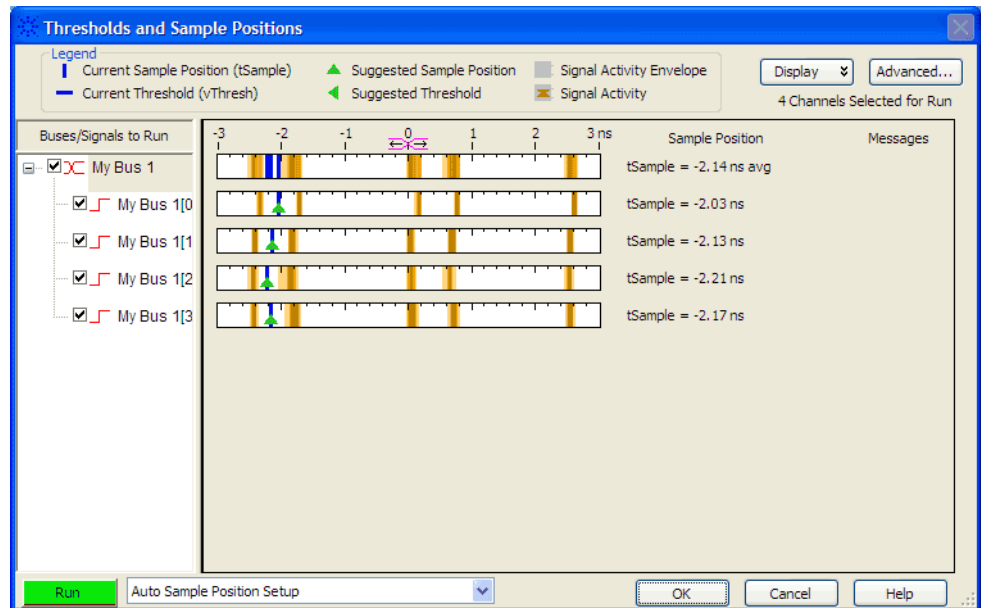

Note that in this step, you place the blue bars in the first narrow window (not the wide window) that appears to the left of zero in the *eye finder* display.

- g** Bring stray channels into alignment if necessary. See page 45.
- h** Click “OK” to close the Thresholds and Sample Positions dialog.
- i** Now, select “Both Edges” for Pod1 Clk1.



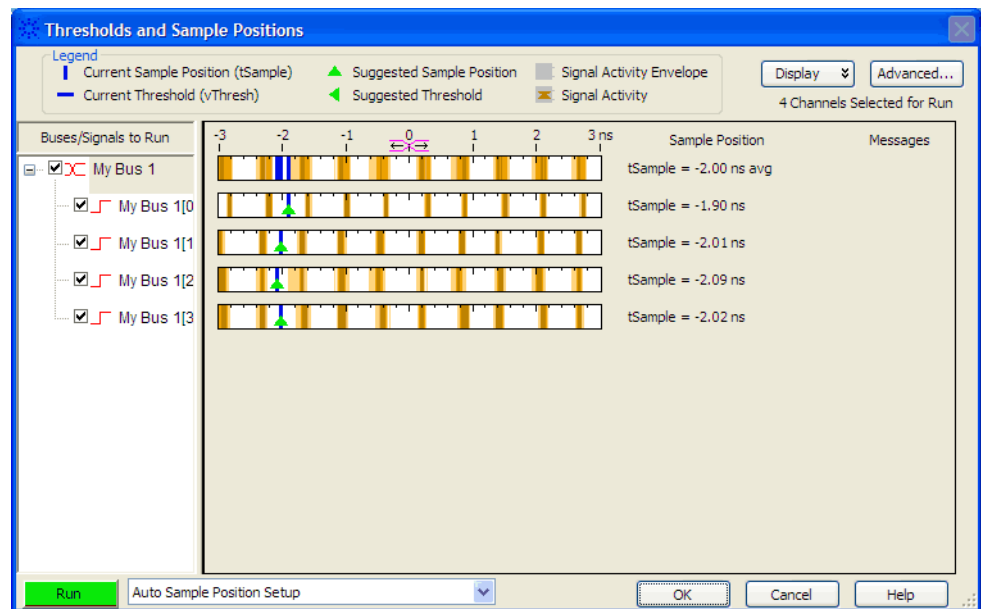

- j** Click “Thresholds and Sample Positions...”.
- k** In the Thresholds and Sample Positions dialog, align the blue bars vertically. See page 43.
- l** Grab the blue bar for “My Bus 1” and move it to the recommended starting position you noted in the prior step.
- m** Click “Run” (the green button in the lower left-hand corner of the dialog) again.

Some eyes may close, but the eyes in the sampling position you chose on page 62 should remain open.





- 12** Perform the procedure “Determine PASS/FAIL (1 of 2 tests):” on page 46.
- 13** Make sure the logic analyzer is set up for testing data acquisition:

- a** In the Listing window, make sure the logic analyzer is set up to trigger on My Bus 1 value “A”.
 - b** Click the  Run icon.
 - c** Make sure the search marker is set up to search for 131072 occurrences of A's or 5's. See page 46.
- 14** Click the  Run Repetitive icon.
- 15** Perform the procedure “Determine PASS/FAIL (2 of 2 tests):” on page 47.
- 16** Test the complement of the bits:
- a** On the 8133A pulse generator, in the PULSE setup for CHANNEL 2, select COMP.
 - b** Note that the signal on the oscilloscope has moved. Change the oscilloscope's horizontal position to -300 ps (or as required) to center the measured pulse on the oscilloscope display.
 - c** Verify the DC offset and adjust it if necessary. See page 36.
 - d** Deskew the oscilloscope. See page 37.
 - e** Adjust the measured pulse width to 750 ps (minus the test margin). See page 60.
 - f** Run *eye finder*.
 - g** Perform the procedure “Determine PASS/FAIL (1 of 2 tests):” on page 46.
 - h** Click the  Run Repetitive icon.
 - i** Perform the procedure “Determine PASS/FAIL (2 of 2 tests):” on page 47.

Test Pod 2 in 800 Mb/s mode

- 1** Change test equipment connections:
 - a** Leave the first E5382A Flying Lead Probe Set connected to Pod 1 of the logic analyzer. Remove the Pod 1 flying leads 2, 6, 10, and 14 from the SMA/Flying Lead test connectors. Do not remove the flying leads that are connected to CLK and $\overline{\text{CLK}}$ flying leads.
 - b** Connect the Pod 2 E5382A Flying Lead Probe Set's bits 6 and 14 to the SMA/Flying Lead test connector's pin strip connector at the 8133A pulse generator's Channel 2 OUTPUT.
 - c** Connect the Pod 2 E5382A Flying Lead Probe Set's bits 2 and 10 to the SMA/Flying Lead test connector's pin strip connector at the 8133A pulse generator's Channel 2 $\overline{\text{OUTPUT}}$.
- 2** On the 8133A pulse generator, in the PULSE setup for CHANNEL 2, press the COMP button to return the outputs to normal.
- 3** Note that the signal on the oscilloscope has moved. Change the oscilloscope's horizontal position to 450 ps (or as required) to center the measured pulse on the oscilloscope display.
- 4** Verify the DC offset and adjust it if necessary. See page 36.
- 5** Deskew the oscilloscope if necessary. See page 37.
- 6** Adjust the measured pulse width from the pulse generator to 750 ps (minus the test margin) as described on page 60.
- 7** Change the logic analyzer pod assignment to use Pod 2. See page 58.
- 8** Re-assign bits to "My Bus 1":
 - a** Click the  Bus/Signal Setup icon.
 - b** In the Analyzer Setup dialog's Buses/Signals tab, re-assign the "My Bus 1" bus name to bits 2, 6, 10, and 14 of Pod 2.

(The threshold voltages for Pod 2 and the Pod 1 clock were previously set up to "1 V" and "differential", respectively.)
 - c** Click "OK" to close the Analyzer Setup dialog.
- 9** Adjust the sampling positions using *eye finder*. Be sure to expand "My Bus 1". You can use the starting position you noted on page 62. Bring stray channels into alignment if necessary. See page 45.

- 10 Determine pass or fail (1 of 2 tests). See page 46.
- 11 Make sure the logic analyzer is set up for testing data acquisition:
 - a In the Listing window, make sure the logic analyzer is set up to trigger on My Bus 1 value “A”.
 - b Click the  Run icon.
 - c Make sure the search marker is set up to search for 131072 occurrences of A's or 5's. See page 46.
- 12 Click the  Run Repetitive icon.
- 13 Determine pass or fail (2 of 2 tests). See page 47.
- 14 Test the complement of the bits on Pod 2. You can use the procedure “Test the complement of the bits:” on page 64 as a guideline.

Test Pod 1 in 1250 Mb/s mode



- 1 Change test equipment connections:
 - a Disconnect the Pod 2 E5382A Flying Lead Probe Set's bits 2, 6, 10, and 14 from the SMA/Flying Lead test connectors' pin strip connectors.

The original E5382A Flying Lead Probe Set should still be connected to Pod 1. The Pod 1 clock will be used for all tests.
 - b Connect the Pod 1 E5382A Flying Lead Probe Set's bits 6 and 14 to the SMA/Flying Lead test connector's pin strip connector at the 8133A pulse generator's Channel 2 OUTPUT.
 - c Connect the Pod 1 E5382A Flying Lead Probe Set's bits 2 and 10 to the SMA/Flying Lead test connector's pin strip connector at the 8133A pulse generator's Channel 2 OUTPUT.
- 2 On the 8133A pulse generator, in the PULSE setup for CHANNEL 2, press the COMP button to return the outputs to normal.
- 3 Note that the signal on the oscilloscope has moved. Change the oscilloscope's horizontal position to 450 ps (or as required) to center the measured pulse on the oscilloscope display.

NOTE:

You can temporarily reduce the frequency on the pulse generator and increase the horizontal scale on the oscilloscope to verify that you are measuring the correct pulse. Then return the settings to normal.

- 4 Verify the DC offset and adjust it if necessary. See page 36.
- 5 Set the frequency of the pulse generator. The logic analyzer will be tested using a double-edge clock. The test frequency is half the test clock rate because data is acquired on both the rising edge and the falling edge of the clock. Set the frequency to 625 MHz plus the frequency uncertainty of the pulse generator, plus a test margin of 1%.

For example, if you are using an 8133A pulse generator, the frequency accuracy is $\pm 1\%$ of setting. Use a test margin of 1%. Set the frequency to 625 MHz plus 2% (638 MHz).
- 6 Verify the oscilloscope Deskew and adjust if necessary. See page 37.
- 7 Adjust the measured pulse width from the pulse generator to 750 ps (minus the test margin) as described on page 60.
- 8 Change the sampling option:
 - a Click the  Sampling Setup icon.
 - b In the Analyzer Setup dialog's Sampling tab, select the "1250 Mb/s Half Channel" Sampling Option.
 - c Click "OK" to close the Analyzer Setup dialog.
- 9 Change the logic analyzer pod assignment to use Pod 1. See page 53.
- 10 Re-assign bits to "My Bus 1":
 - a Click the  Bus/Signal Setup icon.
 - b In the Analyzer Setup dialog's Buses/Signals tab, re-assign the "My Bus 1" bus name to bits 2, 6, 10, and 14 of Pod 1.

(The threshold voltages for Pod 1 and the Pod 1 clock were previously set up to "1 V" and "differential", respectively.)
 - c Click "OK" to close the Analyzer Setup dialog.
- 11 Adjust sampling positions using *eye finder*:

In the 1250 Mb/s mode, only double-edge clocking ("Both Edges") is available. Therefore, we will use a different method for ensuring that we are measuring the correct eye.
 - a Set the pulse generator frequency to half of the required value. If it was set to 638 MHz, then temporarily set it to 319 MHz.
 - b Click the  Sampling Setup icon.

- c** In the Analyzer Setup dialog's Sampling tab, click "Thresholds and Sample Positions...".
- d** In the Thresholds and Sample Positions dialog, expand the "My Bus 1" bus name so you can see the individual signals in the bus.
- e** Grab the blue bar for "My Bus 1" and move it to approximately -0.94 ns. All blue bars will follow.
- f** Click "Run" (the green button in the lower left-hand corner of the dialog).

Note the average sampling position chosen by *eye finder*: _____ ns.

In the following example, the average sampling position is -0.97 ns. The position may be different based on your test setup.

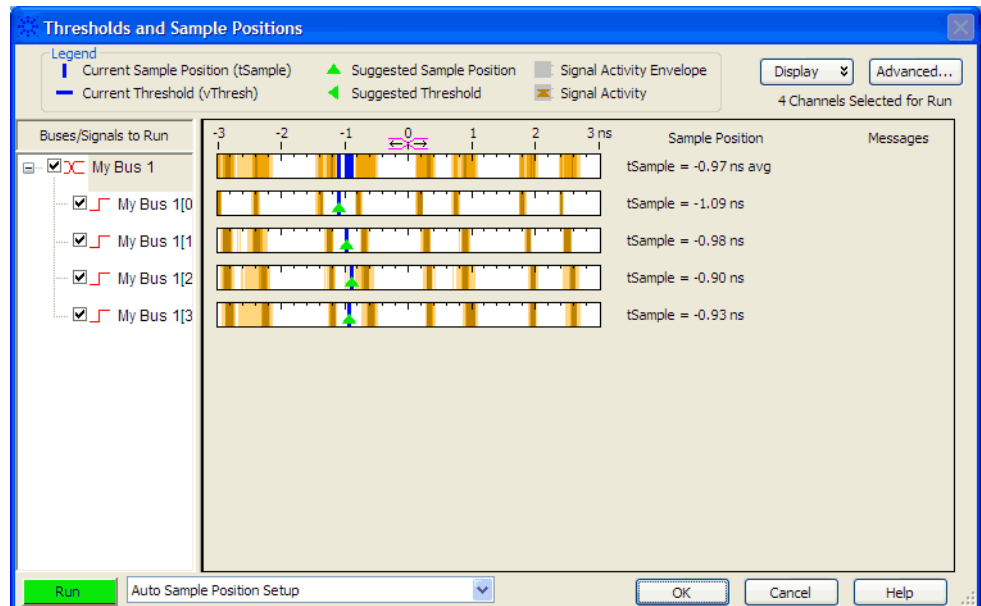



Note that in this step, you place the blue bars in the first narrow window (not the wide window) that appears to the left of zero in the *eye finder* display.

- g** Bring stray channels into alignment if necessary. See page 45.
- h** Re-set the pulse generator frequency to 625 MHz plus the test margin (638 MHz).
- i** Align the blue bars vertically. See page 43.
- j** Grab the blue bar for "My Bus 1" and move it to the recommended starting position you noted in the prior step.

- k** Click “Run” (the green button in the lower left-hand corner of the dialog) again.

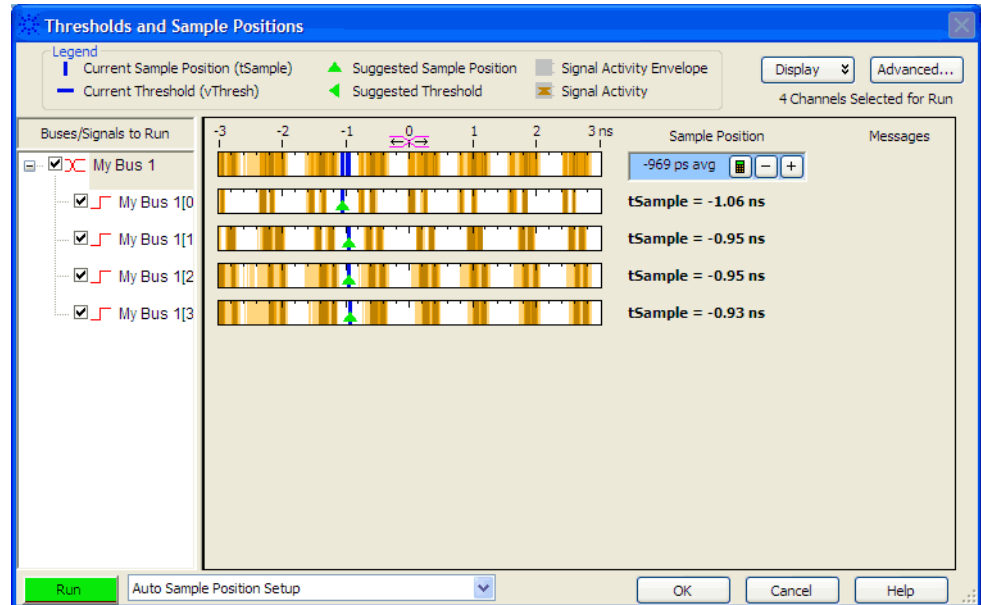
Some eyes may close, but the eyes in the sampling position you chose on page 68 should remain open.





- l** Re-align stray blue bars if necessary. See page 45.
- 12** Perform the procedure “Determine PASS/FAIL (1 of 2 tests):” on page 46.
- 13** Make sure the logic analyzer is set up for testing data acquisition:
 - a** In the Listing window, make sure the logic analyzer is set up to trigger on My Bus 1 value “A”.
 - b** Click the  Run icon.
 - c** Make sure the search marker is set up to search for 131072 occurrences of A's or 5's. See page 46.
- 14** Click the  Run Repetitive icon.
- 15** Perform the procedure “Determine PASS/FAIL (2 of 2 tests):” on page 47.
- 16** Test the complement of the bits:
 - a** On the 8133A pulse generator, in the PULSE setup for CHANNEL 2, select COMP.

- b** Note that the signal on the oscilloscope has moved. Change the oscilloscope's horizontal position to -300 ps (or as required) to center the measured pulse on the oscilloscope display.
- c** Verify the DC offset and adjust it if necessary. See page 36.
- d** Deskew the oscilloscope. See page 37.
- e** Adjust the measured pulse width from the pulse generator to 750 ps (minus the test margin) as described on page 60.
- f** Run *eye finder*.
- g** Perform the procedure "Determine PASS/FAIL (1 of 2 tests):" on page 46.
- h** Click the  Run Repetitive icon.
- i** Perform the procedure "Determine PASS/FAIL (2 of 2 tests):" on page 47.

Test Pod 2 in 1250 Mb/s mode

- 1** Change test equipment connections:
 - a** Leave the first E5382A Flying Lead Probe Set connected to Pod 1 of the logic analyzer. Remove the Pod 1 flying leads 2, 6, 10, and 14 from the SMA/Flying Lead test connectors. Do not remove the flying leads that are connected to CLK and $\overline{\text{CLK}}$ flying leads.
 - b** Connect the Pod 2 E5382A Flying Lead Probe Set's bits 6 and 14 to the SMA/Flying Lead test connector's pin strip connector at the 8133A pulse generator's Channel 2 OUTPUT.
 - c** Connect the Pod 2 E5382A Flying Lead Probe Set's bits 2 and 10 to the SMA/Flying Lead test connector's pin strip connector at the 8133A pulse generator's Channel 2 $\overline{\text{OUTPUT}}$.
- 2** On the 8133A pulse generator, in the PULSE setup for CHANNEL 2, press the COMP button to return the outputs to normal.
- 3** Note that the signal on the oscilloscope has moved. Change the oscilloscope's horizontal position to 450 ps (or as required) to center the measured pulse on the oscilloscope display.
- 4** Verify the DC offset and adjust it if necessary. See page 36.
- 5** Deskew the oscilloscope if necessary. See page 37.

- 6** Adjust the measured pulse width from the pulse generator to 750 ps (minus the test margin) as described on page 60.
- 7** Change the logic analyzer pod assignment to use Pod 2. See page 58.
- 8** Re-assign bits to “My Bus 1”:
 - a** Click the  Bus/Signal Setup icon.
 - b** In the Analyzer Setup dialog’s Buses/Signals tab, re-assign the “My Bus 1” bus name to bits 2, 6, 10, and 14 of Pod 2.

(The threshold voltages for Pod 2 and the Pod 1 clock were previously set up to “1 V” and “differential”, respectively.)
 - c** Click “OK” to close the Analyzer Setup dialog.
- 9** Adjust the sampling positions using *eye finder*. Be sure to expand “My Bus 1”. You can use the starting position you noted on page 68. Re-align any stray channels if necessary. See page 45.
- 10** Determine pass or fail (1 of 2 tests). See page 46.
- 11** Make sure the logic analyzer is set up for testing data acquisition:
 - a** In the Listing window, make sure the logic analyzer is set up to trigger on My Bus 1 value “A”.
 - b** Click the  Run icon.
 - c** Make sure the search marker is set up to search for 131072 occurrences of A’s or 5’s. See page 46.
- 12** Click the  Run Repetitive icon.
- 13** Determine pass or fail (2 of 2 tests). See page 47.
- 14** Test the complement of the bits on Pod 2. You can use the procedure “Test the complement of the bits:” on page 69 as a guideline.

Test Pod 1 in 1500 Mb/s mode

- 1 Change test equipment connections:
 - a Disconnect the Pod 2 E5382A Flying Lead Probe Set's bits 2, 6, 10, and 14 from the SMA/Flying Lead test connectors' pin strip connectors.

The original E5382A Flying Lead Probe Set should still be connected to Pod 1. The Pod 1 clock will be used for all tests.
 - b Connect the Pod 1 E5382A Flying Lead Probe Set's bits 6 and 14 to the SMA/Flying Lead test connector's pin strip connector at the 8133A pulse generator's Channel 2 OUTPUT.
 - c Connect the Pod 1 E5382A Flying Lead Probe Set's bits 2 and 10 to the SMA/Flying Lead test connector's pin strip connector at the 8133A pulse generator's Channel 2 OUTPUT.
- 2 On the 8133A pulse generator, in the PULSE setup for CHANNEL 2, press the COMP button to return the outputs to normal.
- 3 Note that the signal on the oscilloscope has moved. Change the oscilloscope's horizontal position to 450 ps (or as required) to center the measured pulse on the oscilloscope display.

NOTE:

You can temporarily reduce the frequency on the pulse generator and increase the horizontal scale on the oscilloscope to verify that you are measuring the correct pulse. Then return the settings to normal.

- 4 Verify the DC offset and adjust it if necessary. See page 36.
- 5 Set the frequency of the pulse generator. The logic analyzer will be tested using a double-edge clock. The test frequency is half the test clock rate because data is acquired on both the rising edge and the falling edge of the clock. Set the frequency to 750 MHz plus the frequency uncertainty of the pulse generator, plus a test margin of 1%.

For example, if you are using an 8133A pulse generator, the frequency accuracy is $\pm 1\%$ of setting. Use a test margin of 1%. Set the frequency to 750 MHz plus 2% (765 MHz).
- 6 Verify the oscilloscope Deskew and adjust if necessary. See page 37.
- 7 Adjust the measured pulse width to 600 ps:

In this procedure, you will use the oscilloscope's measurement markers to measure the actual pulse width in the test setup. Then you will adjust the pulse generator so that the measured pulse width is as specified.

- a** Observe the 54845A oscilloscope display. Change the Channel 2 pulse width of the 8133A pulse generator so that the pulse width measured at 1 volt on the oscilloscope is equal to 600 ps minus the measurement uncertainty and display resolution of the oscilloscope, further reduced by 35 ps for test margin.



For example, if you are using the 54845A/B oscilloscope, the measurement uncertainty is $\pm((0.007\% * \Delta t) + (\text{full scale}/2x \text{ memory depth}) + 30 \text{ ps}) \cong \pm 30 \text{ ps}$. Add 5 ps for display resolution. Add 35 ps test margin.

$$600 \text{ ps} - 30 \text{ ps} - 5 \text{ ps} - 35 \text{ ps} = 530 \text{ ps}$$

Therefore, set the pulse width as measured on the 54845A/B oscilloscope to 530 ps.

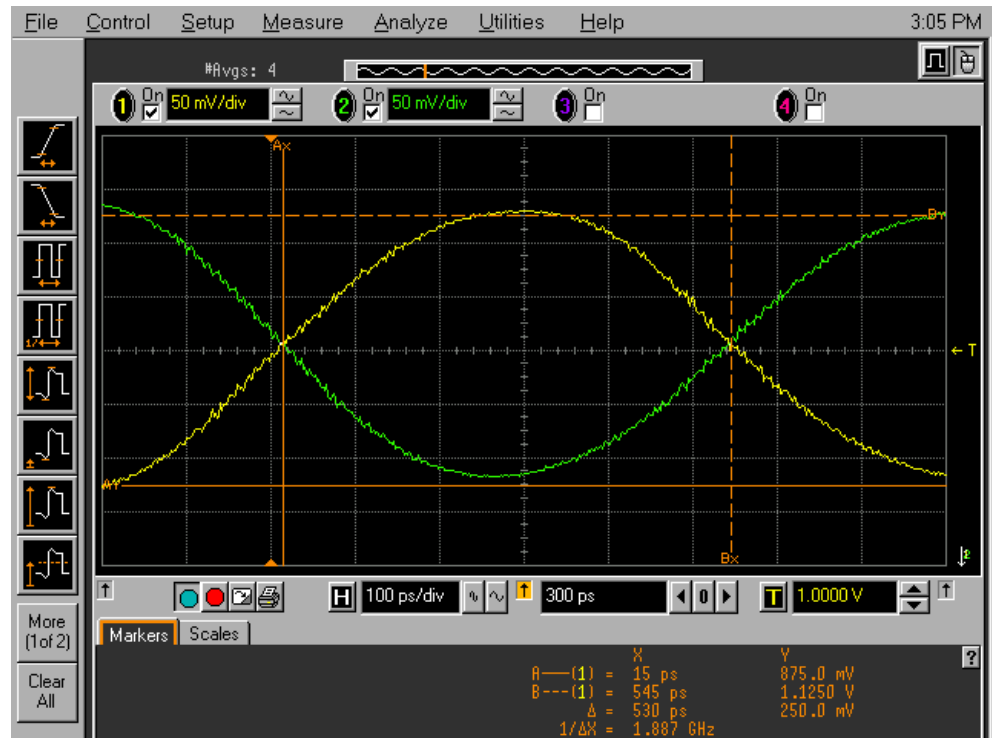
- b** In the oscilloscope horizontal setup, change the position to 300 ps (or as required) to center the pulse on the display.
- c** On the oscilloscope, move the Ax and Bx markers to the crossing points of the pulse and the horizontal center line. Read the pulse width at the bottom of the oscilloscope display. It is displayed as “ Δ ”.



- 8** Change the sampling option:
 - a** Click the  Sampling Setup icon.
 - b** In the Analyzer Setup dialog's Sampling tab, select the "1500 Mb/s Half Channel" Sampling Option.
 - c** Click "OK" to close the Analyzer Setup dialog.
- 9** Change the logic analyzer pod assignment to use Pod 1. See page 53.
- 10** Re-assign bits to "My Bus 1":
 - a** Click the  Bus/Signal Setup icon.
 - b** In the Analyzer Setup dialog's Buses/Signals tab, re-assign the "My Bus 1" bus name to bits 2, 6, 10, and 14 of Pod 1.

(The threshold voltages for Pod 1 and the Pod 1 clock were previously set up to "1 V" and "differential", respectively.)
 - c** Click "OK" to close the Analyzer Setup dialog.
- 11** Adjust sampling positions using *eye finder*:
 - a** Set the pulse generator frequency to half of the required value. If it was set to 765 MHz, then temporarily set it to 383 MHz.
 - b** Click the  Sampling Setup icon.
 - c** In the Analyzer Setup dialog's Sampling tab, click "Thresholds and Sample Positions...".
 - d** In the Thresholds and Sample Positions dialog, expand the "My Bus 1" bus name so you can see the individual signals in the bus.
 - e** Grab the blue bar for "My Bus 1" and move it to approximately 3.1 ns. All blue bars will follow.
 - f** Click "Run" (the green button in the lower left-hand corner of the dialog).

Note the average sampling position chosen by *eye finder*: _____ns.

In the following example, the average sampling position is 3.10 ns. The position may be different based on your test setup.

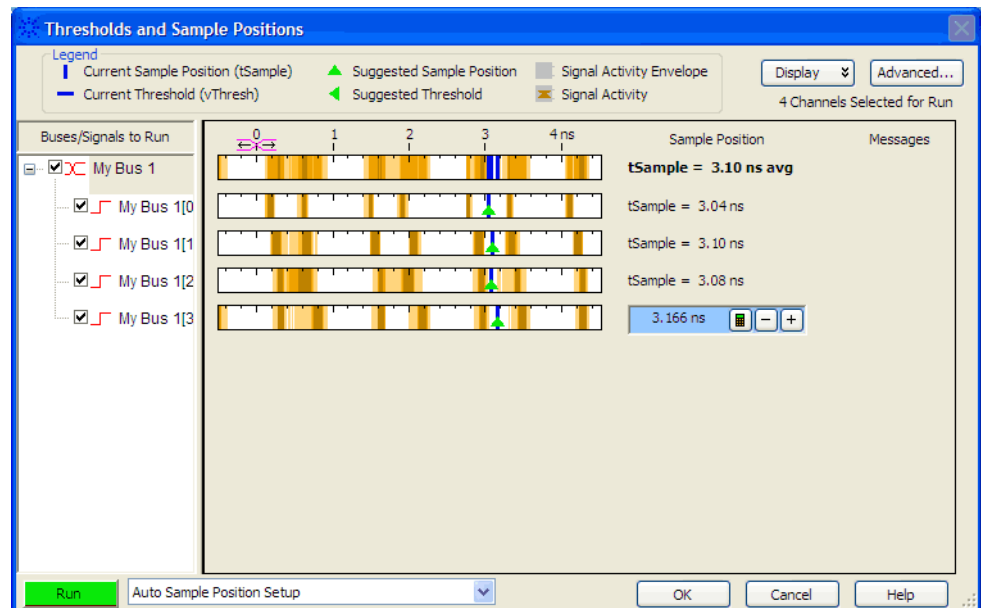



Note that in this step, you place the blue bars in the last complete narrow window that appears on the right in the *eye finder* display.

- g** Bring stray channels into alignment if necessary. See page 45.
- h** Re-set the pulse generator frequency to 750 MHz plus the test margin (765 MHz).
- i** Align the blue bars vertically. See page 43.
- j** Grab the blue bar for “My Bus 1” and move it to the recommended starting position you noted in the prior step.
- k** Click “Run” (the green button in the lower left-hand corner of the dialog) again.

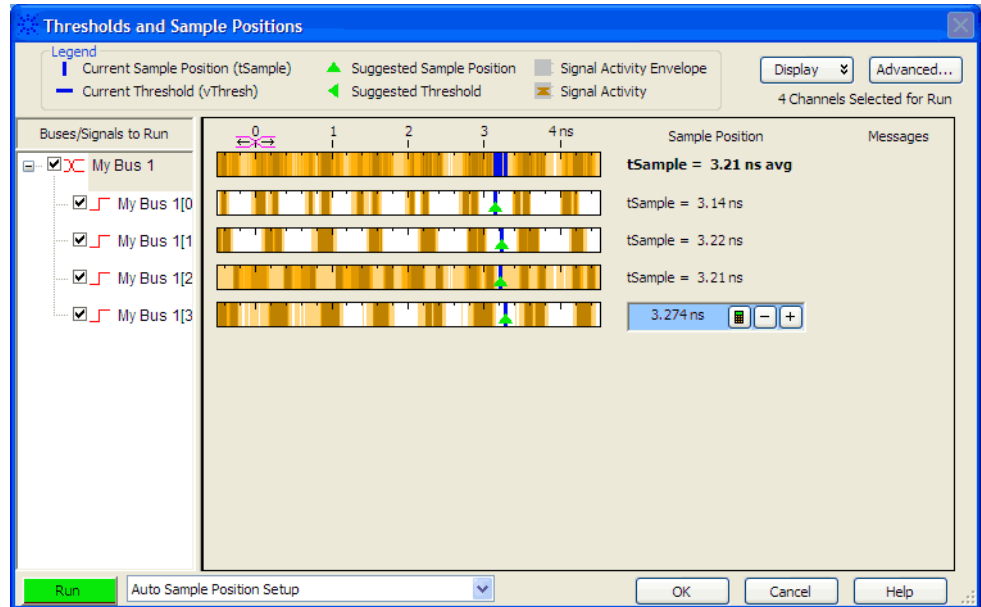
Some eyes may close, but the eyes in the sampling position you chose on page 74 should remain open.





- 1** Re-align stray blue bars if necessary. See page 45.
- 12** Perform the procedure “Determine PASS/FAIL (1 of 2 tests):” on page 46.
- 13** Make sure the logic analyzer is set up for testing data acquisition:
 - a** In the Listing window, make sure the logic analyzer is set up to trigger on My Bus 1 value “A”.
 - b** Click the  Run icon.
 - c** Make sure the search marker is set up to search for 131072 occurrences of A's or 5's. See page 46.
- 14** Click the  Run Repetitive icon.
- 15** Perform the procedure “Determine PASS/FAIL (2 of 2 tests):” on page 47.
- 16** Test the complement of the bits:
 - a** On the 8133A pulse generator, in the PULSE setup for CHANNEL 2, select COMP.
 - b** Note that the signal on the oscilloscope has moved. Change the oscilloscope's horizontal position to -350 ps (or as required) to center the measured pulse on the oscilloscope display.
 - c** Verify the DC offset and adjust it if necessary. See page 36.

- d** Deskew the oscilloscope. See page 37.
- e** Verify that the pulse width is set to 600 ps. See page 72.
- f** Run *eye finder*.
- g** Perform the procedure “Determine PASS/FAIL (1 of 2 tests):” on page 46.
- h** Click the  Run Repetitive icon.
- i** Perform the procedure “Determine PASS/FAIL (2 of 2 tests):” on page 47.

Test Pod 2 in 1500 Mb/s mode

- 1** Change test equipment connections:
 - a** Leave the first E5382A Flying Lead Probe Set connected to Pod 1 of the logic analyzer. Remove the Pod 1 flying leads 2, 6, 10, and 14 from the SMA/Flying Lead test connectors. Do not remove the flying leads that are connected to CLK and $\overline{\text{CLK}}$ flying leads.
 - b** Connect the Pod 2 E5382A Flying Lead Probe Set’s bits 6 and 14 to the SMA/Flying Lead test connector’s pin strip connector at the 8133A pulse generator’s Channel 2 OUTPUT.
 - c** Connect the Pod 2 E5382A Flying Lead Probe Set’s bits 2 and 10 to the SMA/Flying Lead test connector’s pin strip connector at the 8133A pulse generator’s Channel 2 OUTPUT.
- 2** On the 8133A pulse generator, in the PULSE setup for CHANNEL 2, press the COMP button to return the outputs to normal.
- 3** Note that the signal on the oscilloscope has moved. Change the oscilloscope’s horizontal position to 300 ps (or as required) to center the measured pulse on the oscilloscope display.
- 4** Verify the DC offset and adjust it if necessary. See page 36.
- 5** Deskew the oscilloscope if necessary. See page 37.
- 6** Adjust the measured pulse width from the pulse generator to 600 ps (minus the test margin) as described on page 72.
- 7** Change the logic analyzer pod assignment to use Pod 2. See page 58.

- 8** Re-assign bits to “My Bus 1”:
 - a** Click the  Bus/Signal Setup icon.
 - b** In the Analyzer Setup dialog’s Buses/Signals tab, re-assign the “My Bus 1” bus name to bits 2, 6, 10, and 14 of Pod 2.

(The threshold voltages for Pod 2 and the Pod 1 clock were previously set up to “1 V” and “differential”, respectively.)
 - c** Click “OK” to close the Analyzer Setup dialog.
- 9** Adjust the sampling positions using *eye finder*. Be sure to expand “My Bus 1”. You can use the starting position you noted on page 74. Re-align any stray channels if necessary. See page 45.
- 10** Determine pass or fail (1 of 2 tests). See page 46.
- 11** Make sure the logic analyzer is set up for testing data acquisition:
 - a** In the Listing window, make sure the logic analyzer is set up to trigger on My Bus 1 value “A”.
 - b** Click the  Run icon.
 - c** Make sure the search marker is set up to search for 131072 occurrences of A’s or 5’s. See page 46.
- 12** Click the  Run Repetitive icon.
- 13** Determine pass or fail (2 of 2 tests). See page 47.
- 14** Test the complement of the bits on Pod 2. You can use the procedure “Test the complement of the bits:” on page 76 as a guideline.

Manual Test Procedure, 16700-Series Mainframe

The steps that follow include pass/fail criteria.

Test Pod 1 in 200 Mb/s Mode

1 Configure the logic analyzer:

a Configure the Sampling settings:

- i In the Agilent 16700-series logic analysis system's System window, select the 16760A logic analyzer icon, then select "Setup and Trigger". A Setup and Trigger window will appear.
- ii In the logic analyzer Setup and Trigger window, select the Sampling tab (if it is not already selected).
- iii Under the Sampling tab, select State Mode.
- iv Under State Mode Controls, select the "200 Mb/s / 32 M State" mode.
- v Under Clock Setup, at the bottom of the Clock J column, select the clock edge field and set the J clock to "Both Edges".

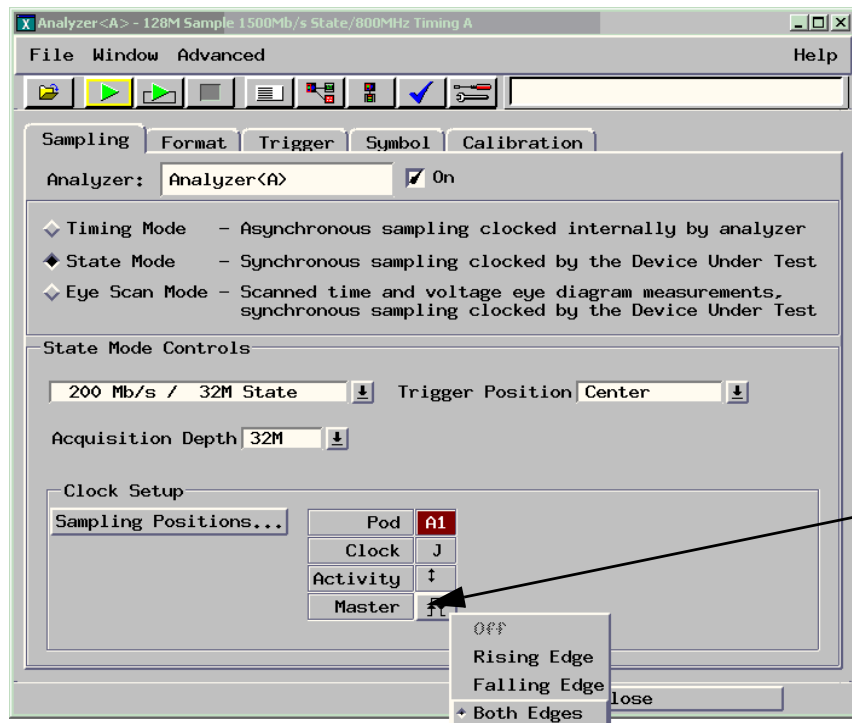

b Configure the Acquisition settings:

- i** In the logic analyzer Setup and Trigger window, select the Trigger tab.
- ii** Under the Trigger tab, select the Settings subtab.
- iii** Select the Acquisition Depth field, then select 128K.
- iv** Select the Trigger Position field, then select Start.
- v** Select the Count field, then select Off.

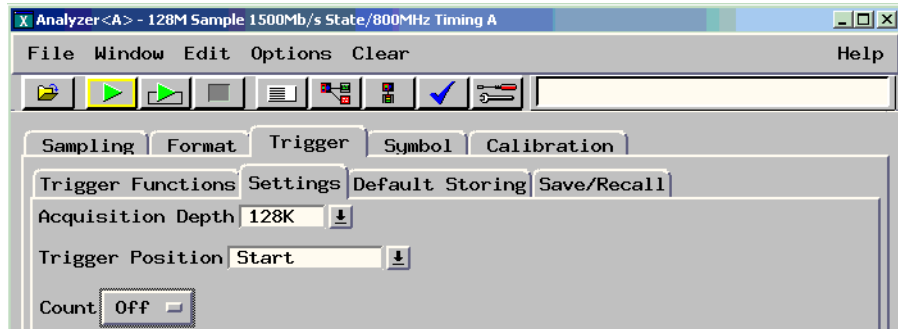

c Configure the Format settings:

- i** In the logic analyzer Setup and Trigger window, select the Format tab.
- ii** Under the Format tab, select Pod Assignment.
- iii** In the Pod Assignment window, use the mouse to drag the pod from the Unassigned Pods column to the Analyzer 1 column.

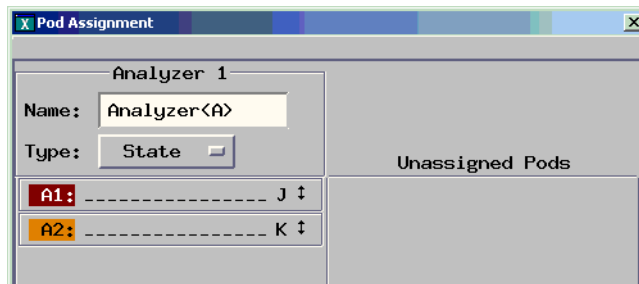

- iv** Select Close to close the Pod Assignment window.

- v Under the Format tab, use the scroll bar to scroll to the right so you can see the fields for Pod 1.

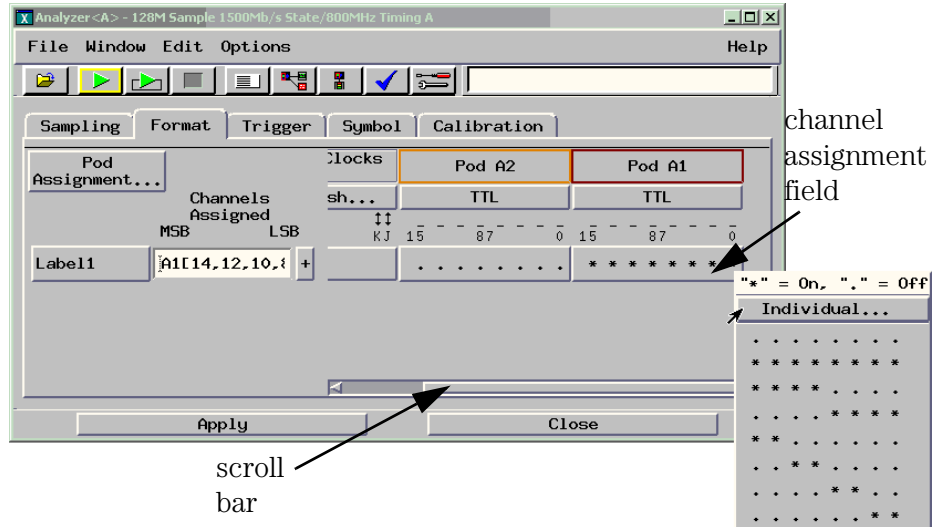

- vi Select the channel assignment field for the pod being tested, then select Individual in the pop-up menu.
- vii Using the mouse, select each asterisk to un-assign all data channels on the pod. Ensure all channels are un-assigned on all pods. Now assign channels 2, 6, 10, and 14 for the pod being tested (Pod 1). An asterisk (*) means that a channel is assigned.

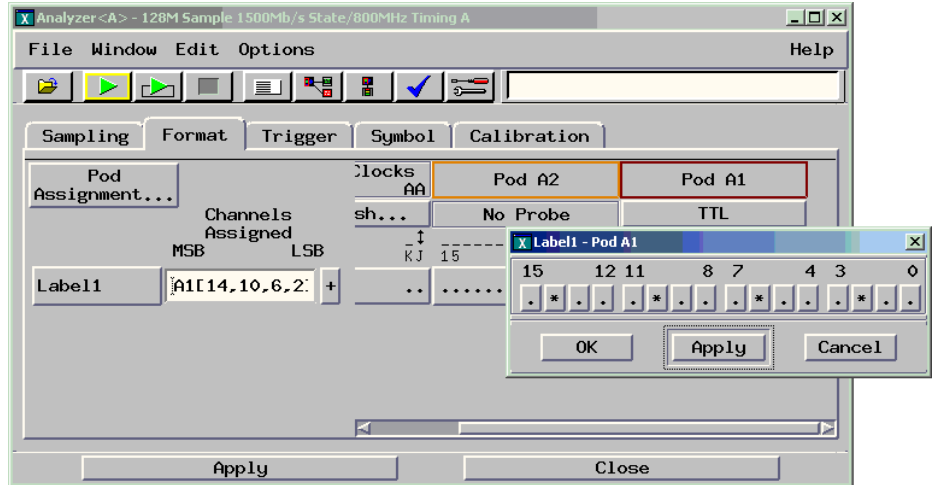

- viii Select OK to close the channel assignment window.

d Configure the clock and data thresholds:

- i** Select the pod threshold field for the pod that you are going to test. The Pod threshold window will appear. You must have the E5382A Flying Lead Probe attached to the pod you will be testing so that the pod threshold dialog will appear when you select the pod threshold field.

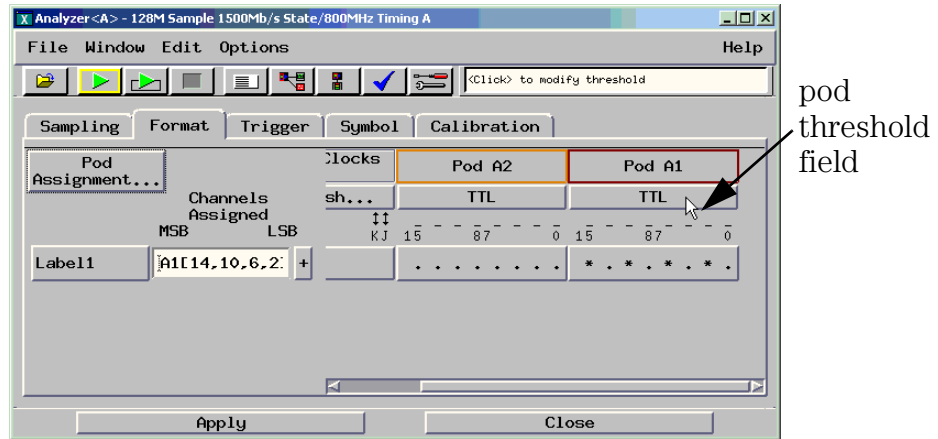

- ii** In the Pod threshold window, select User Defined and set the threshold value to 1 volt. The “Apply threshold settings to all pods” check box doesn’t matter.

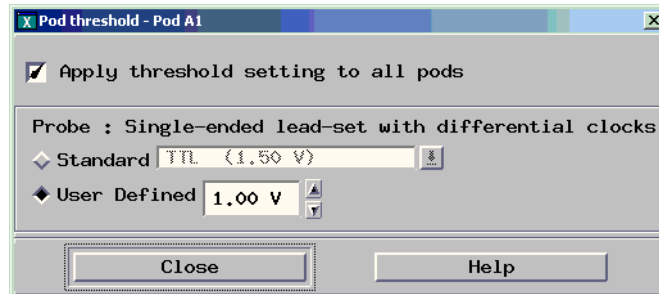

- iii** Select Close to close the Pod threshold window.

- iv Under the Format tab, use the scroll bar at the bottom of the window to scroll to the left and select “Clk Thresh...”.

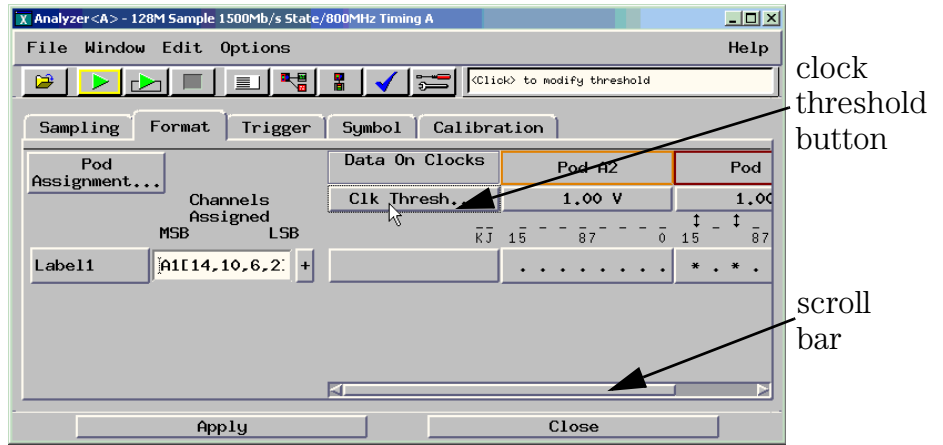

- v In the Clock Thresholds window, select the J clock threshold button, then in the J threshold window select Differential.

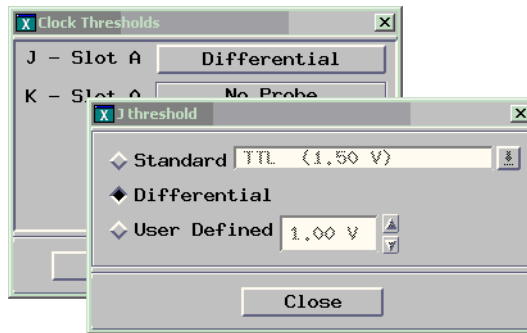

- vi Select Close to close the J threshold window. Select Close to close the Clock Thresholds window.
- e Configure the Trigger settings:
 - i In the logic analyzer Setup and Trigger window, under the Trigger tab, select the Trigger Functions subtab.
 - ii Select “Find pattern n times”.
 - iii Select the Replace button.

- iv Enter “A” in the “Label 1 =” field.

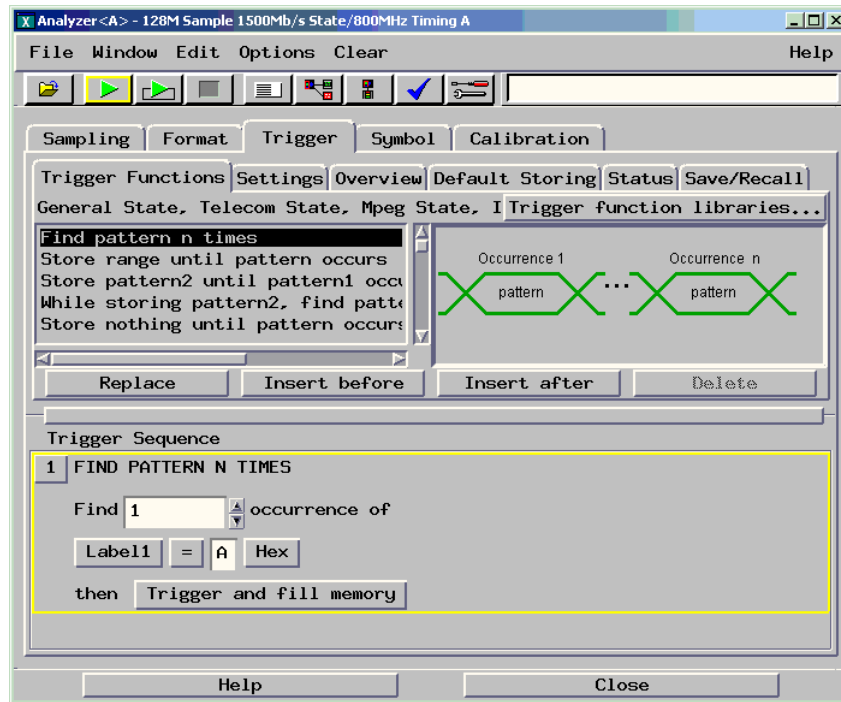

2 Adjust sampling positions using *eye finder*:

- a In the Setup and Trigger window, select the Sampling tab, then select the “Sampling Positions...” button (which is in the Clock Setup area of the window). The *eye finder* window will appear. Ensure that the “Sampling Positions” tab is selected.
- b From the menu bar in the *eye finder* window, select Results.
- c Select “Remove All Eye Finder Data” if this selection is available (if it is not ghosted). Select “Yes” to confirm that you want to remove the data.
- d Select Label1, then select Expand (if not already expanded).
- e If the blue bars in the *eye finder* display are not vertically aligned:
 - i Grab the right-most blue bar in the “Label1 (4 channels)” row with the mouse pointer and move it all the way to the left and release the mouse button. This will vertically align all of the blue bars.
- f Select the Sampling Positions tab in the *eye finder* window.
- g Using the mouse pointer, grab the blue bar for “Label 1 (4 channels)” and move it to the recommended starting position of 0.6 ns. All of the blue bars will follow.

- h** Click “Run Eye Finder” (the large green button).
- i** Ensure that an eye appears for each bit near the recommended starting position. Depending on your test setup, the eye position may vary. Any skew between channel 1 and channel 2 of your pulse generator will cause the eye position to shift to the left or right in the *eye finder* display. A shift of up to 0.5 ns should be considered normal. The important point is that your *eye finder* display should look similar to the picture below (although it may be shifted left or right), and *eye finder* must be able to place the blue bars in the narrow eye.

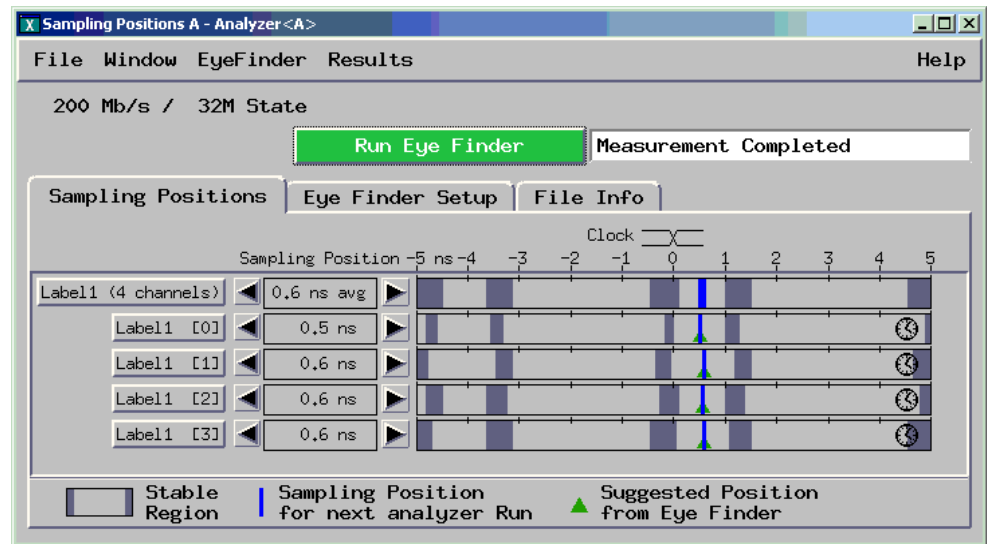

- j** Re-align any stray channels if necessary. See page 86.

Re-Aligning a Stray Channel

If the blue bar for a particular bit does not appear in its eye near the recommended starting position, you need to re-align the sampling position of the stray channel. In the following example, the sampling position of one channel (Label1 [2]) must be re-aligned with the sampling position of the other channels. (The following example shows the analyzer in the 1500 Mb/s mode.)

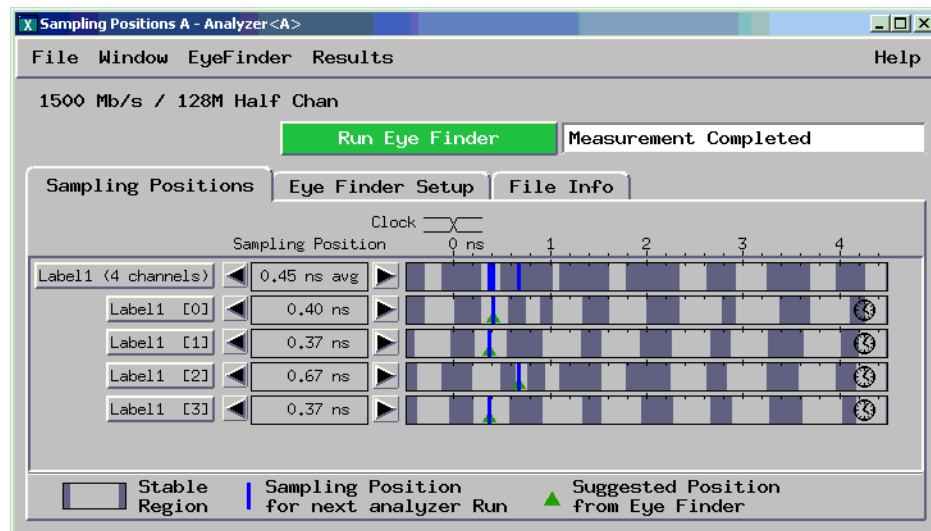

Using the mouse, drag the sample position (blue line) of a stray channel so that it is in the same eye as the other channels (drag channel Label1 [2] in the above example). The Suggested Position from *eye finder* (green triangle) will also move to the new eye. Do this for all remaining stray channels.

Click "Run Eye Finder". *Eye finder* will recalculate the new sample positions based on the sample position changes. The following example shows all sampling positions aligned and in the correct eye (with the analyzer in the 1500 Mb/s mode).

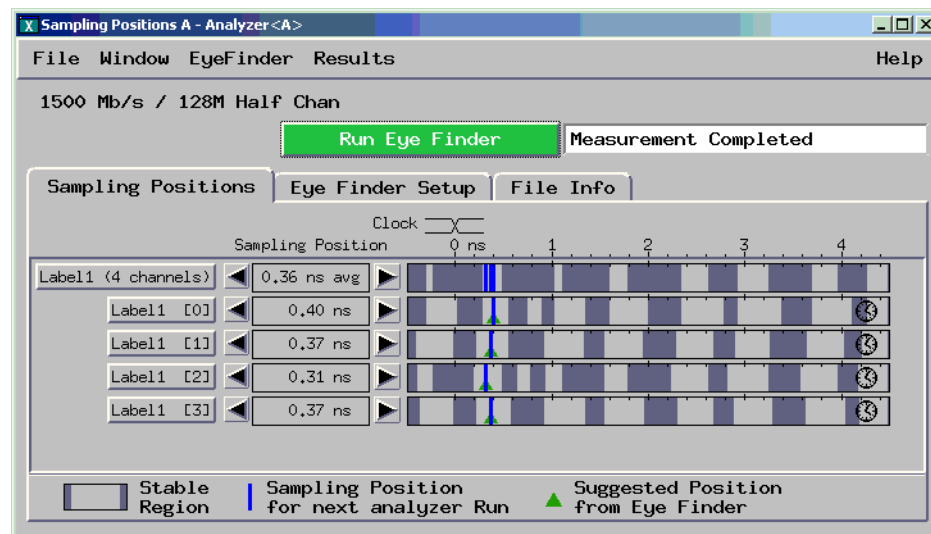

3 Determine PASS/FAIL (1 of 2 tests):

- a** PASS/FAIL: If an eye exists near the recommended starting position for every bit, and *eye finder* places a blue bar in the eye for each bit, then the logic analyzer passes this portion of the test.
- b** If an eye does not exist near the recommended starting position for every bit or *eye finder* cannot place the blue bar in the eye, then the logic analyzer fails the test. Record the failure in the test record (shown on page 118).

4 Open and configure the Listing window:

- a** In the Setup and Trigger window, select Window from the menu bar, then select Slot n: Analyzer<n> (where n is the slot where the module under test is installed). At the pop-up menu, select Listing. The Listing window will appear.

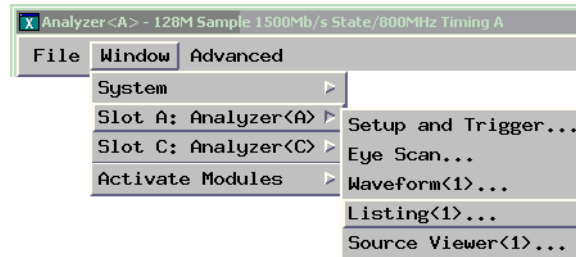

- b** In the Listing window, select the Markers tab.

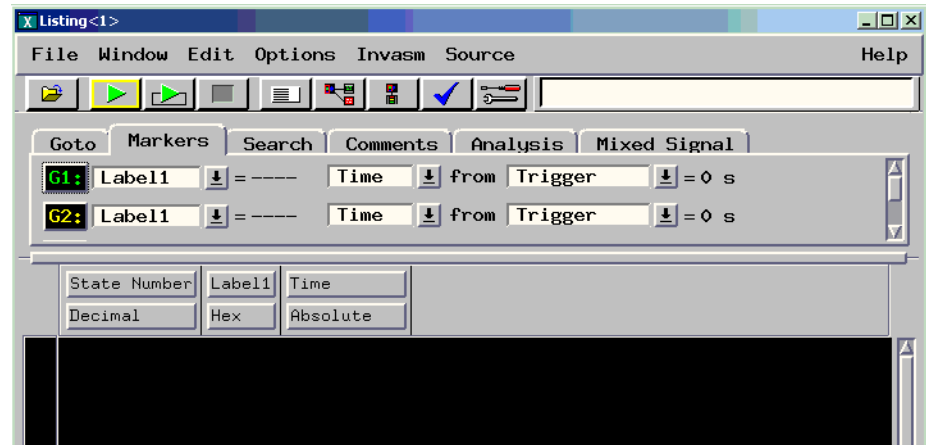

- c** Select the G1: button and the Markers Setup window will appear.
- d** Select the field immediately to the right of G1, and select Pattern.
- e** Select the field immediately to the right of G2, and select Pattern.

- f Right-click on the Interval field (which is below G1 and G2) and select Delete.
- g Select the field immediately to the right of “Data at” and select Beginning.

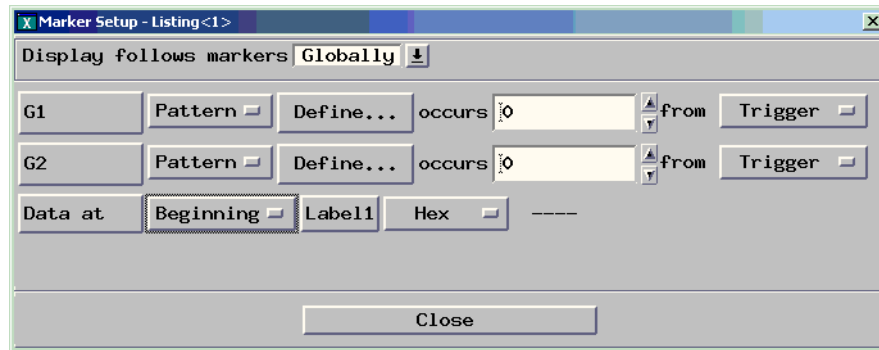

NOTE:

Leave the marker Setup window open. You will be entering numeric values in the "occurs" field after acquiring the first run of test data.

- h Configure the Markers.
 - i In the logic analyzer Listing window, select the Run icon. This will load the logic analyzer memory with data so the markers can be configured. An error message will appear because the marker patterns are not yet specified.
 - ii Select OK to close the error message window.
 - iii In the Marker Setup window, select the G1 Define... button. The “Marker Pattern for <G1>” window will appear. In the pattern field, enter "a", then select Close.

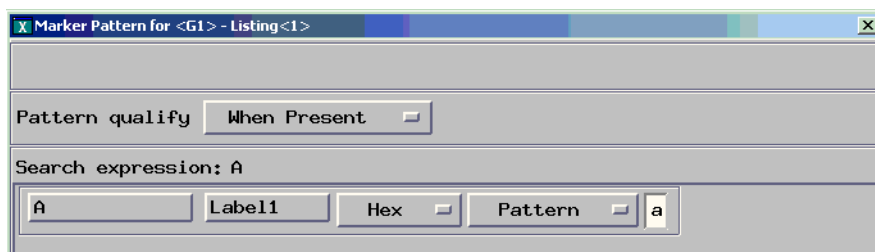

- iv In the Marker Setup window, select the G2 Define... button. The G2 Marker Pattern window will appear. In the pattern field, enter "5", then select Close.
- v In the Marker Setup window, select the 'occurs' value field that corresponds to marker G1. Enter 65535.
- vi In the Marker Setup window, select the 'occurs' value field that

corresponds to marker G2. Enter 65535, then press Enter.

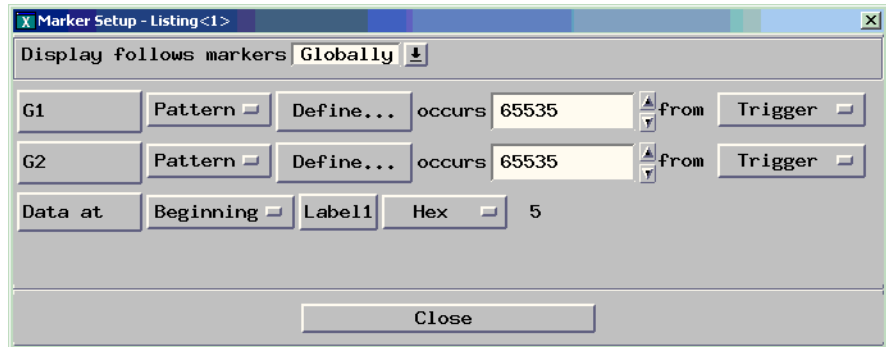

vii Select Close.

i In the Listing window, Select the Run Repetitive icon. The analyzer will run and the listing window will update every few seconds.

5 Determine PASS/FAIL (2 of 2 tests):

Pass/Fail Point: The Listing window is set up to search for the appropriate number of A's and 5's in the acquisition. If the logic analyzer does not detect the correct number of A's and 5's, an error window will appear. The window will be named 'Error - Listing', and it will say "Pattern NOT found for marker...".

a Let the logic analyzer run repetitive for about 1 minute. If no error message is displayed, the test passes.

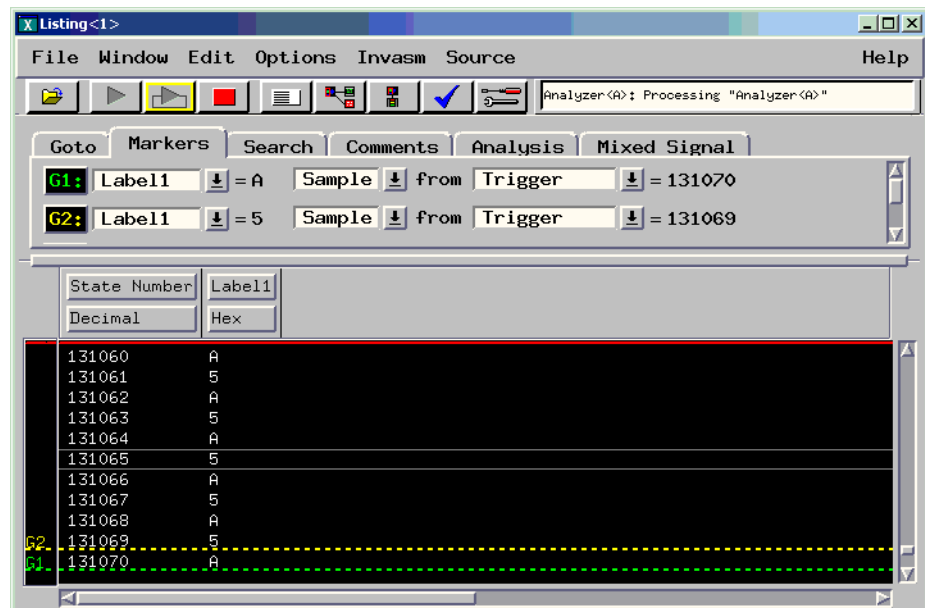

If the red error window “Error- Listing <1> Pattern NOT found...” appears during the minute or so that it runs repetitively, then the logic analyzer fails the test. Record the failure in the appropriate place on the test record.



NOTE: Be sure that the black ground clip is making good contact with the ground pin on the test connector.

- b** After approximately 1 minute select the red stop button in the Listing window.

NOTE: As a point of curiosity, you may want to determine the absolute minimum pulse width and/or absolute maximum frequency at which data can be acquired. The “Performance Test Record” on page 118 does not include places for recording these values because the Performance Verification procedure only verifies that the logic analyzer meets specifications. Determination of additional parameters is not required, but may be performed at the discretion of the calibration laboratory.

On some pulse generators, the signal outputs may become slightly unstable for a very short period of time when the signal parameters are adjusted. Adjusting the pulse generator while the logic analyzer is running can cause a false failure.

If the Pattern NOT found error message appears while making an adjustment to the pulse generator select OK to close the window. If the message appears again after you have stopped adjusting the pulse generator and allowed a short settling time for the pulse generator, then the logic analyzer fails the test.

-
- 6** Test the complement of the bits:
 - a** On the 8133A pulse generator, in the PULSE setup for CHANNEL 2, select COMP.
 - b** Note that the signal on the oscilloscope has moved. Change the oscilloscope’s horizontal position to -600 ps (or as required) to center the measured pulse on the oscilloscope display.
 - c** Verify the DC offset and adjust it if necessary. See page 36.
 - d** Deskew the oscilloscope if necessary. See page 37.

- e Adjust the oscilloscope's measurement markers to measure the pulse width. Set the markers so that $\Delta=1430$ ps (this assumes you are using the 8133A pulse generator and the Infiniium oscilloscope). Adjust the pulse generator so that the pulse width is 1430 ps as measured by the markers. See page 38 for details.

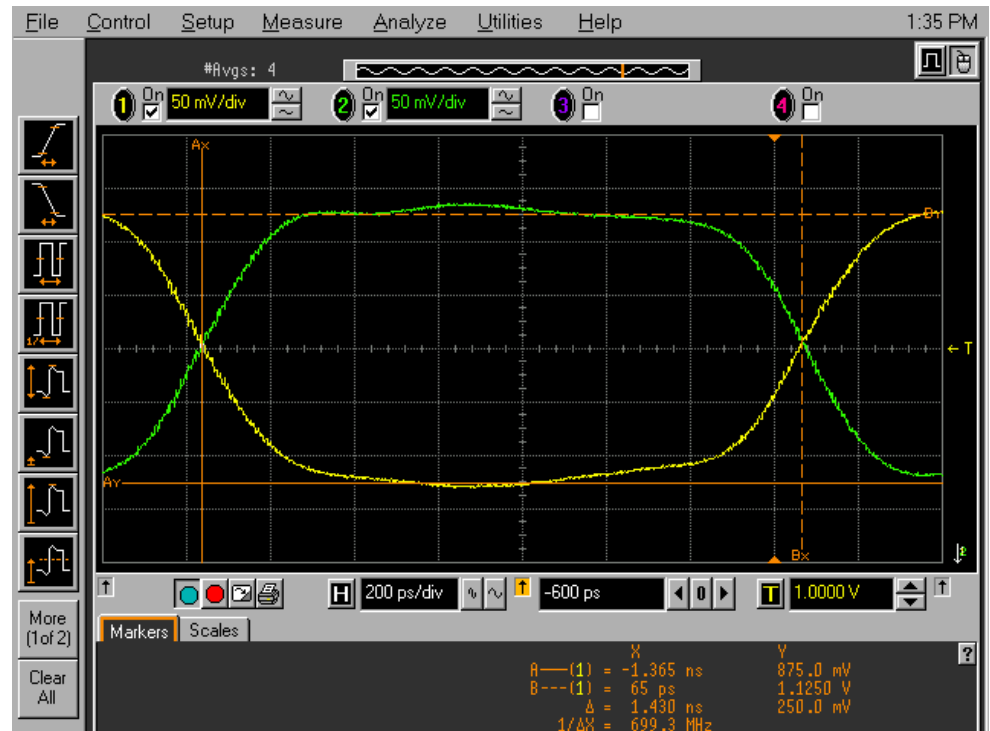

- f Adjust the sampling positions (run *eye finder*). See page 84.
- g Determine pass or fail (1 of 2 tests). See page 87.
- h Ensure that the Listing window is set up. See page 87.
- i Select the Run Repetitive icon in the Listing window.
- j Determine pass or fail (2 of 2 tests). See page 89.

Test Pod 2 in 200 Mb/s Mode

- 1 Change test equipment connections:
 - a Leave the first E5382A Flying Lead Probe Set connected to Pod 1 of the logic analyzer. Remove the Pod 1 flying leads 2, 6, 10, and 14 from the

SMA/Flying Lead test connectors. Do not remove the flying leads that are connected to CLK and $\overline{\text{CLK}}$.

- b** Connect the second E5382A Flying Lead Probe Set to Pod 2 of the logic analyzer.
 - c** Connect the Pod 2 E5382A Flying Lead Probe Set's bits 6 and 14 to the SMA/Flying Lead test connector's pin strip connector at the 8133A pulse generator's Channel 2 OUTPUT.
 - d** Connect the Pod 2 E5382A Flying Lead Probe Set's bits 2 and 10 to the SMA/Flying Lead test connector's pin strip connector at the 8133A pulse generator's Channel 2 OUTPUT.
- 2** On the 8133A pulse generator, in the PULSE setup for CHANNEL 2, press the COMP button to return the outputs to normal.
 - 3** Note that the signal on the oscilloscope has moved. Change the oscilloscope's horizontal position to 800 ps (or as required) to center the measured pulse on the oscilloscope display.
 - 4** Verify the DC offset and adjust it if necessary. See page 36.
 - 5** Deskew the oscilloscope if necessary. See page 37.
 - 6** Re-adjust the pulse width from the pulse generator as measured on the oscilloscope to 1.5 ns. See page 38.
 - 7** Change the logic analyzer configuration:
 - a** In the logic analyzer's Setup and Trigger window, Format tab, unassign all pod 1 bits. A Warning window will appear stating that the trigger function has become invalid. Select OK to close the Warning window.
 - b** Assign bits 2, 6, 10, and 14 of Pod 2.
 - c** Set the Pod 2 threshold to 1 volt (just as you did for Pod 1 on page 82).
 - d** In the "Setup and Trigger..." window, Format tab, use the scroll bar at the bottom of the window to scroll to the left. Ensure that the J clock threshold is set to Differential.
 - e** Re-establish the trigger function:
 - i** In the logic analyzer's Setup and Trigger window, select the Trigger tab, and the Trigger Functions subtab.
 - ii** Select "Find pattern n times" and select the "Replace" button.
 - iii** Enter "A" in the "Label 1 = " field.

- 8** Adjust the sampling positions using *eye finder*. Be sure to expand “Label1 (4 channels)” and use the recommended starting position noted on page 84. Re-align any stray channels if necessary. See page 86.
- 9** Determine pass or fail (1 of 2 tests). See page 87.
- 10** Ensure that the Listing window is set up. See page 87.
- 11** Select the Run Repetitive icon in the Listing window.
- 12** Determine pass or fail (2 of 2 tests). See page 89.
- 13** Test the complement of the bits. See page 90.

Test Pod 1 in 400 Mb/s mode

- 1** Change test equipment connections:
 - a** Disconnect the Pod 2 E5382A Flying Lead Probe Set’s bits 2, 6, 10, and 14 from the SMA/Flying Lead test connectors’ pin strip connectors.

The original E5382A Flying Lead Probe Set should still be connected to Pod 1. The J clock on Pod 1 will be used for all tests.
 - b** Connect the Pod 1 E5382A Flying Lead Probe Set’s bits 6 and 14 to the SMA/Flying Lead test connector’s pin strip connector at the 8133A pulse generator’s Channel 2 OUTPUT.
 - c** Connect the Pod 1 E5382A Flying Lead Probe Set’s bits 2 and 10 to the SMA/Flying Lead test connector’s pin strip connector at the 8133A pulse generator’s Channel 2 OUTPUT.
- 2** On the 8133A pulse generator, in the PULSE setup for CHANNEL 2, press the COMP button to return the outputs to normal.
- 3** Note that the signal on the oscilloscope has moved. Change the oscilloscope’s horizontal position to 800 ps (or as required) to center the measured pulse on the oscilloscope display.
- 4** Verify the DC offset and adjust it if necessary. See page 36.
- 5** Set the frequency of the pulse generator. The logic analyzer will be tested using a double-edge clock. The test frequency is half the test clock rate because data is acquired on both the rising edge and the falling edge of the clock. Set the frequency to 200 MHz plus the frequency uncertainty of the pulse generator, plus a test margin of 1%.

For example, if you are using an 8133A pulse generator, the frequency accuracy is $\pm 1\%$ of setting. Use a test margin of 1%. Set the frequency to 200 MHz plus 2% (204 MHz).

- 6** Verify the oscilloscope Deskew and adjust if necessary. See page 37.
- 7** Adjust the measured pulse width from the pulse generator to 1.5 ns (minus the test margin) as described on page 38.
- 8** Change the logic analyzer configuration:
 - a** In the logic analyzer “Setup and Trigger...” window, select the Sampling tab. In the “State Mode Controls” section, select the “400 Mb/s / 32M State” mode. The mode will change to 400 Mb/s and the clock setup will change to “Rising Edge.”
 - b** In the logic analyzer’s Setup and Trigger window, Format tab, unassign all pod 2 bits.
 - c** Assign bits 2, 6, 10, and 14 of Pod 1.
 - d** Ensure that the Pod 1 threshold is set to 1 volt. See page 82.
 - e** In the “Setup and Trigger...” window, Format tab, ensure that the J clock threshold is still set to Differential.
 - f** Re-establish the trigger function:
 - i** In the logic analyzer’s Setup and Trigger window, select the Trigger tab, and the Trigger Functions subtab.
 - ii** Select “Find pattern n times” and select the “Replace” button.
 - iii** Enter “A” in the “Label 1 = “ field.
- 9** Adjust sampling positions using *eye finder*:
 - a** In the “Setup and Trigger...” window, Sampling tab, Clock Setup area, ensure that the clock mode is set to “Rising Edge”.

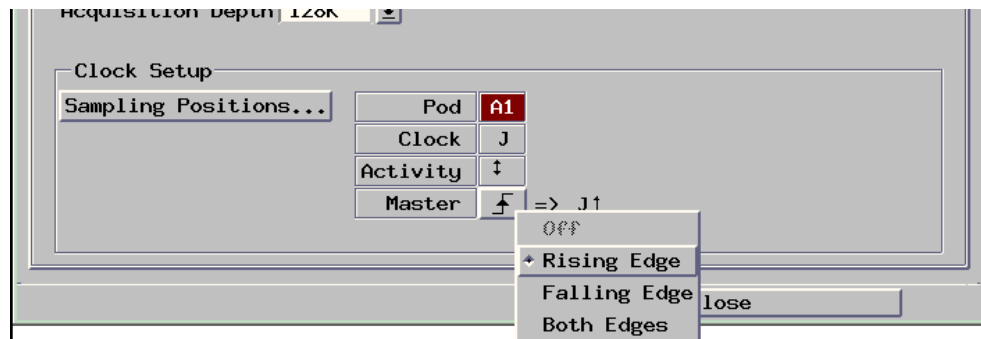

- b** In the *eye finder* (Sampling Positions) window, expand “Label1 (4 channels)”.
- c** Grab the blue bar for “Label1 (4 Channels)” and move it to approximately 0.9 ns. All blue bars will follow.
- d** Click “Run Eye Finder” and note the average sampling position chosen by *eye finder*: _____ ns. Note that in this step, you place the blue bars in the first narrow window (not the wide window) that appears to the right of zero in the *eye finder* display. Then run *eye finder*.

In the following example, the average sampling position is 0.9 ns. The position may be different based on your test setup.

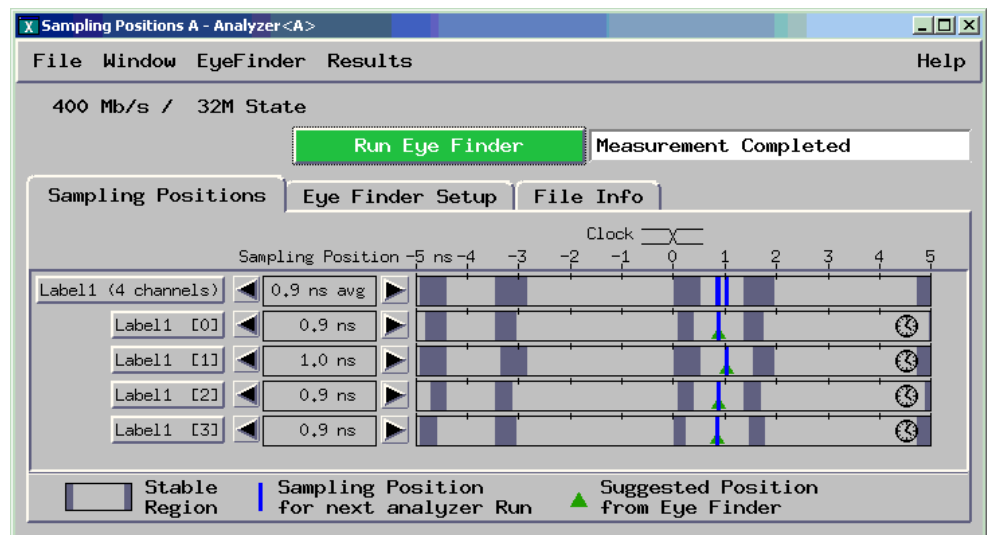

- e** Bring stray channels into alignment if necessary. See page 86.
- f** In the “Setup and Trigger...” window, Clock Setup area, set the clock mode to “Both Edges.”
- g** In the *eye finder* window, align the blue bars vertically. See page 84.
- h** Grab the blue bar for “Label1 (4 Channels)” and move it to the recommended starting position you noted in the prior step.

- i** Click “Run Eye Finder” again. Some eyes may close, but the eyes in the sampling position you chose on page 95 should remain open.

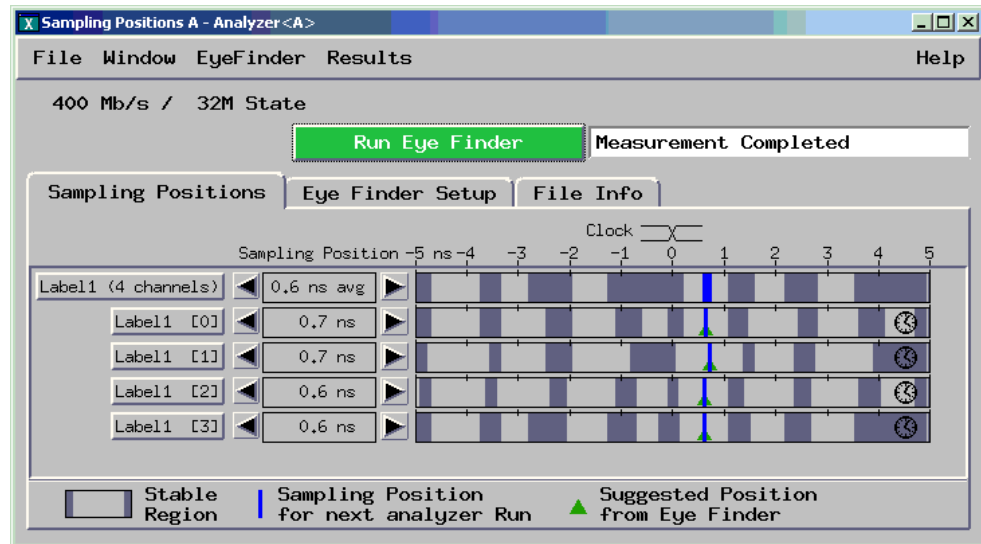

- 10** Perform the procedure “Determine PASS/FAIL (1 of 2 tests):” on page 87.
- 11** Select the Run Repetitive icon in the Listing window.
- 12** Perform the procedure “Determine PASS/FAIL (2 of 2 tests):” on page 89.
- 13** Test the complement of the bits:
 - a** On the 8133A pulse generator, in the PULSE setup for CHANNEL 2, select COMP.
 - b** Note that the signal on the oscilloscope has moved. Change the oscilloscope’s horizontal position to -600 ps (or as required) to center the measured pulse on the oscilloscope display.
 - c** Verify the DC offset and adjust it if necessary. See page 36.
 - d** Deskew the oscilloscope. See page 37.
 - e** Verify that the pulse width is set to 1.5 ns. See page 38.
 - f** Run *eye finder*.
 - g** Perform the procedure “Determine PASS/FAIL (1 of 2 tests):” on page 87.
 - h** Select the Run Repetitive icon in the Listing window.
 - i** Perform the procedure “Determine PASS/FAIL (2 of 2 tests):” on page 89.

Test Pod 2 in 400 Mb/s mode

- 1** Change test equipment connections:
 - a** Leave the first E5382A Flying Lead Probe Set connected to Pod 1 of the logic analyzer. Remove the Pod 1 flying leads 2, 6, 10, and 14 from the SMA/Flying Lead test connectors. Do not remove the flying leads that are connected to CLK and $\overline{\text{CLK}}$ flying leads.
 - b** Connect the Pod 2 E5382A Flying Lead Probe Set's bits 6 and 14 to the SMA/Flying Lead test connector's pin strip connector at the 8133A pulse generator's Channel 2 OUTPUT.
 - c** Connect the Pod 2 E5382A Flying Lead Probe Set's bits 2 and 10 to the SMA/Flying Lead test connector's pin strip connector at the 8133A pulse generator's Channel 2 $\overline{\text{OUTPUT}}$.
- 2** On the 8133A pulse generator, in the PULSE setup for CHANNEL 2, press the COMP button to return the outputs to normal.
- 3** Note that the signal on the oscilloscope has moved. Change the oscilloscope's horizontal position to 800 ps (or as required) to center the measured pulse on the oscilloscope display.
- 4** Verify the DC offset and adjust it if necessary. See page 36.
- 5** Deskew the oscilloscope if necessary. See page 37.
- 6** Adjust the measured pulse width from the pulse generator to 1.5 ns (minus the test margin) as described on page 38.
- 7** Change the logic analyzer configuration:
 - a** In the logic analyzer's Setup and Trigger window, Format tab, unassign all pod 1 bits.
 - b** Assign bits 2, 6, 10, and 14 of Pod 2.
 - c** Verify that the Pod 2 threshold is set to 1 volt (just as you did for Pod 1 on page 82).
 - d** In the "Setup and Trigger..." window, Format tab, use the scroll bar at the bottom of the window to scroll to the left. Ensure that the J clock threshold is set to Differential.
 - e** Re-establish the trigger function:
 - i** In the logic analyzer's Setup and Trigger window, select the Trigger tab, and the Trigger Functions subtab.

- ii** Select “Find pattern n times” and select the “Replace” button.
 - iii** Enter “A” in the “Label 1 = “ field.
 - 8** Adjust the sampling positions using *eye finder*. Be sure to expand “Label1 (4 channels)”. Use the starting position you noted on page 95. Re-align any stray channels if necessary. See page 86.
 - 9** Determine pass or fail (1 of 2 tests). See page 87.
 - 10** Ensure that the Listing window is set up. See page 87.
 - 11** Select the Run Repetitive icon in the Listing window.
 - 12** Determine pass or fail (2 of 2 tests). See page 89.
 - 13** Test the complement of the bits on Pod 2. You can use the procedure “Test the complement of the bits:” on page 96 as a guideline.
-

Test Pod 1 in 800 Mb/s mode

- 1** Change test equipment connections:
 - a** Disconnect the Pod 2 E5382A Flying Lead Probe Set’s bits 2, 6, 10, and 14 from the SMA/Flying Lead test connectors’ pin strip connectors.

The original E5382A Flying Lead Probe Set should still be connected to Pod 1. The J clock on Pod 1 will be used for all tests.
 - b** Connect the Pod 1 E5382A Flying Lead Probe Set’s bits 6 and 14 to the SMA/Flying Lead test connector’s pin strip connector at the 8133A pulse generator’s Channel 2 OUTPUT.
 - c** Connect the Pod 1 E5382A Flying Lead Probe Set’s bits 2 and 10 to the SMA/Flying Lead test connector’s pin strip connector at the 8133A pulse generator’s Channel 2 OUTPUT.
- 2** On the 8133A pulse generator, in the PULSE setup for CHANNEL 2, press the COMP button to return the outputs to normal.
- 3** Note that the signal on the oscilloscope has moved. Change the oscilloscope’s horizontal position to 800 ps (or as required) to center the measured pulse on the oscilloscope display.
- 4** Verify the DC offset and adjust it if necessary. See page 36.
- 5** Set the frequency of the pulse generator. The logic analyzer will be tested using a double-edge clock. The test frequency is half the test clock rate

because data is acquired on both the rising edge and the falling edge of the clock. Set the frequency to 400 MHz plus the frequency uncertainty of the pulse generator, plus a test margin of 1%.

For example, if you are using an 8133A pulse generator, the frequency accuracy is $\pm 1\%$ of setting. Use a test margin of 1%. Set the frequency to 400 MHz plus 2% (408 MHz).

6 Verify the oscilloscope Deskew and adjust if necessary. See page 37.

7 Adjust the measured pulse width to 750 ps:

In this procedure, you will use the oscilloscope's measurement markers to measure the actual pulse width in the test setup. Then you will adjust the pulse generator so that the measured pulse width is as specified.

a Observe the 54845A oscilloscope display. Change the Channel 2 pulse width of the 8133A pulse generator so that the pulse width measured at 1 volt on the oscilloscope is equal to 750 ps minus the measurement uncertainty and display resolution of the oscilloscope, further reduced by 35 ps for test margin.

For example, if you are using the 54845A/B oscilloscope, the measurement uncertainty is $\pm((0.007\% * \Delta t) + (\text{full scale}/2x \text{ memory depth}) + 30 \text{ ps}) \cong \pm 30 \text{ ps}$. Add 5 ps for display resolution. Add 35 ps test margin.

$$750 \text{ ps} - 30 \text{ ps} - 5 \text{ ps} - 35 \text{ ps} = 680 \text{ ps}$$

Therefore, set the pulse width as measured on the 54845A/B oscilloscope to 680 ps.

b In the oscilloscope horizontal setup, change the position to 450 ps. Change the horizontal scale to 100 ps/div. This will make it easier for you to set the pulse width accurately.

- c On the oscilloscope, move the Ax and Bx markers to the crossing points of the pulse and the horizontal center line. Read the pulse width at the bottom of the oscilloscope display. It is displayed as “Δ=”.

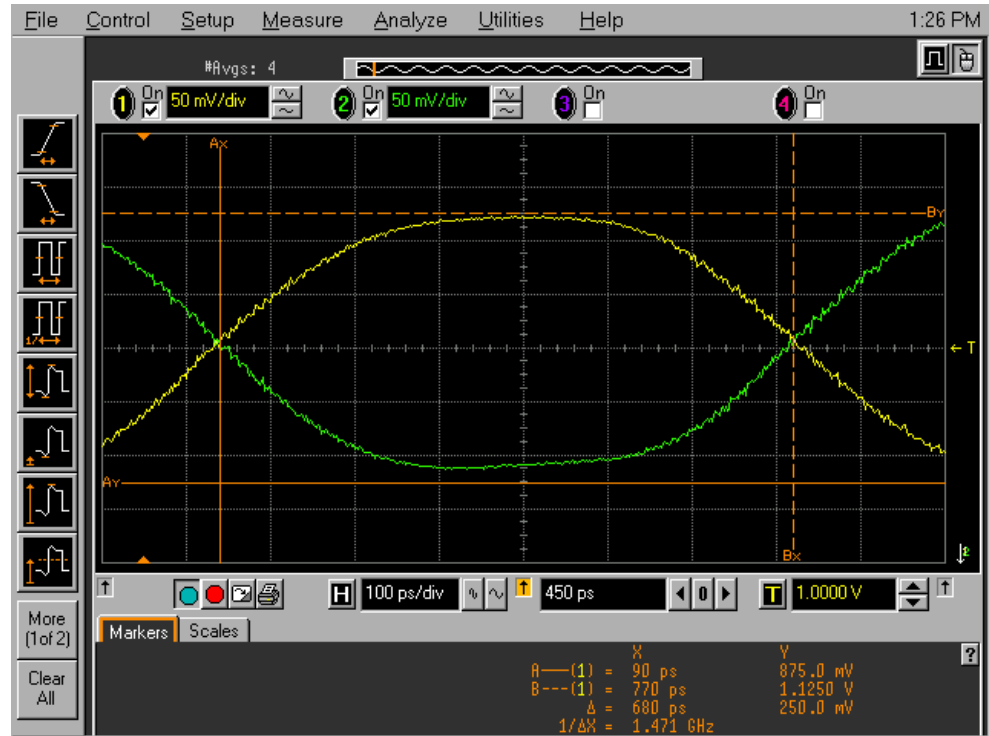

8 Change the logic analyzer configuration:

- a In the logic analyzer “Setup and Trigger...” window, select the Sampling tab. In the “State Mode Controls” section, select the “800 Mb/s / 64M State” mode.
- b In the “Setup and Trigger...” window, Sampling tab, Clock Setup area, set the clock mode to “Rising Edge”.

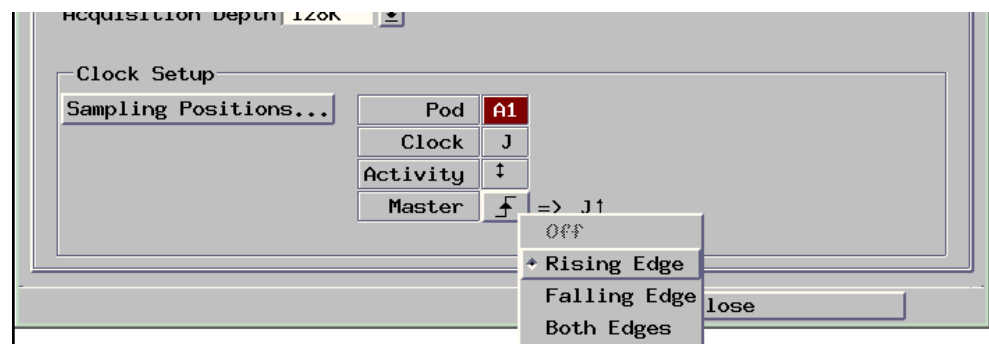

- c** In the logic analyzer's Setup and Trigger window, Format tab, unassign all pod 2 bits.
 - d** Assign bits 2, 6, 10, and 14 of Pod 1.
 - e** Ensure that the Pod 1 threshold is set to 1 volt. See page 82.
 - f** In the "Setup and Trigger..." window, Format tab, ensure that the J clock threshold is still set to Differential.
 - g** Re-establish the trigger function:
 - i** In the logic analyzer's Setup and Trigger window, select the Trigger tab, and the Trigger Functions subtab.
 - ii** Select "Find pattern" and select the "Replace" button.
 - iii** Enter "A" in the "Label 1 = " field.
- 9** Adjust sampling positions using *eye finder*:
- a** In the *eye finder* (Sampling Positions) window, expand "Label1 (4 channels)".
 - b** Grab the blue bar for "Label1 (4 Channels)" and move it to approximately -2.1 ns. All blue bars will follow.

- c Click “Run Eye Finder” and note the average sampling position chosen by *eye finder*: _____ ns. Note that in this step, you place the blue bars in the first narrow window (not the wide window) that appears to the left of zero in the *eye finder* display. Then run *eye finder*.

In the following example, the average sampling position is -2.09 ns. The position may be different based on your test setup.

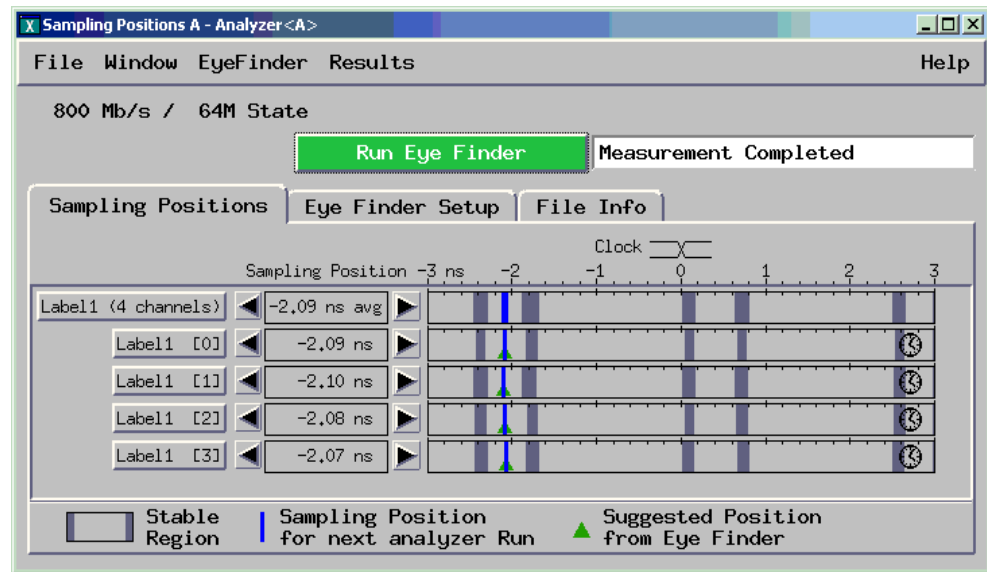

- d Bring stray channels into alignment if necessary. See page 86.
- e In the “Setup and Trigger...” window, Clock Setup area, set the clock mode to “Both Edges.”
- f In the *eye finder* window, align the blue bars vertically. See page 84.
- g Grab the blue bar for “Label1 (4 Channels)” and move it to the recommended starting position you noted in the prior step.

- h** Click “Run Eye Finder” again. Some eyes may close, but the eyes in the sampling position you chose on page 102 should remain open.

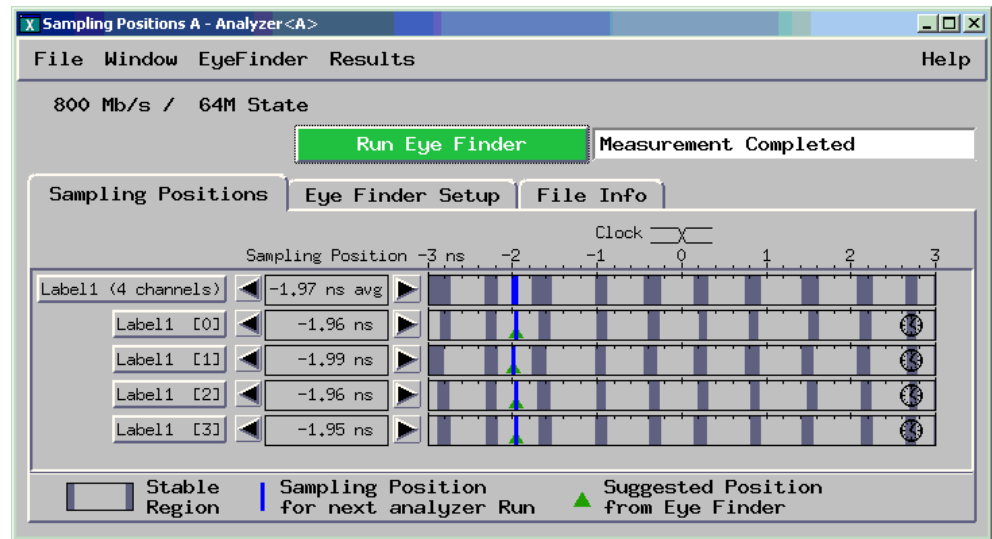

- 10** Perform the procedure “Determine PASS/FAIL (1 of 2 tests):” on page 87.
- 11** Select the Run Repetitive icon in the Listing window.
- 12** Perform the procedure “Determine PASS/FAIL (2 of 2 tests):” on page 89.
- 13** Test the complement of the bits:
- a** On the 8133A pulse generator, in the PULSE setup for CHANNEL 2, select COMP.
 - b** Note that the signal on the oscilloscope has moved. Change the oscilloscope’s horizontal position to -300 ps (or as required) to center the measured pulse on the oscilloscope display.
 - c** Verify the DC offset and adjust it if necessary. See page 36.
 - d** Deskew the oscilloscope. See page 37.
 - e** Adjust the measured pulse width to 750 ps (minus the test margin). See page 99.
 - f** Run *eye finder*.
 - g** Perform the procedure “Determine PASS/FAIL (1 of 2 tests):” on page 87.
 - h** Select the Run Repetitive icon in the Listing window.

- i** Perform the procedure “Determine PASS/FAIL (2 of 2 tests):” on page 89.

Test Pod 2 in 800 Mb/s mode

- 1** Change test equipment connections:
 - a** Leave the first E5382A Flying Lead Probe Set connected to Pod 1 of the logic analyzer. Remove the Pod 1 flying leads 2, 6, 10, and 14 from the SMA/Flying Lead test connectors. Do not remove the flying leads that are connected to CLK and $\overline{\text{CLK}}$ flying leads.
 - b** Connect the Pod 2 E5382A Flying Lead Probe Set’s bits 6 and 14 to the SMA/Flying Lead test connector’s pin strip connector at the 8133A pulse generator’s Channel 2 OUTPUT.
 - c** Connect the Pod 2 E5382A Flying Lead Probe Set’s bits 2 and 10 to the SMA/Flying Lead test connector’s pin strip connector at the 8133A pulse generator’s Channel 2 $\overline{\text{OUTPUT}}$.
- 2** On the 8133A pulse generator, in the PULSE setup for CHANNEL 2, press the COMP button to return the outputs to normal.
- 3** Note that the signal on the oscilloscope has moved. Change the oscilloscope’s horizontal position to 450 ps (or as required) to center the measured pulse on the oscilloscope display.
- 4** Verify the DC offset and adjust it if necessary. See page 36.
- 5** Deskew the oscilloscope if necessary. See page 37.
- 6** Adjust the measured pulse width from the pulse generator to 750 ps (minus the test margin) as described on page 99.
- 7** Change the logic analyzer configuration:
 - a** In the logic analyzer’s Setup and Trigger window, Format tab, unassign all pod 1 bits.
 - b** Assign bits 2, 6, 10, and 14 of Pod 2.
 - c** Verify that the Pod 2 threshold is set to 1 volt (just as you did for Pod 1 on page 82).
 - d** In the “Setup and Trigger...” window, Format tab, use the scroll bar at the bottom of the window to scroll to the left. Verify that the J clock threshold is set to Differential.

- e Re-establish the trigger function:
 - i In the logic analyzer's Setup and Trigger window, select the Trigger tab, and the Trigger Functions subtab.
 - ii Select "Find pattern n times" and select the "Replace" button.
 - iii Enter "A" in the "Label 1 = " field.
- 8 Adjust the sampling positions using *eye finder*. Be sure to expand "Label1 (4 channels)". You can use the starting position you noted on page 102. Bring stray channels into alignment if necessary. See page 86.
- 9 Determine pass or fail (1 of 2 tests). See page 87.
- 10 Ensure that the Listing window is set up. See page 87.
- 11 Select the Run Repetitive icon in the Listing window.
- 12 Determine pass or fail (2 of 2 tests). See page 89.
- 13 Test the complement of the bits on Pod 2. You can use the procedure "Test the complement of the bits:" on page 103 as a guideline.

Test Pod 1 in 1250 Mb/s mode

- 1 Change test equipment connections:
 - a Disconnect the Pod 2 E5382A Flying Lead Probe Set's bits 2, 6, 10, and 14 from the SMA/Flying Lead test connectors' pin strip connectors.

The original E5382A Flying Lead Probe Set should still be connected to Pod 1. The J clock on Pod 1 will be used for all tests.
 - b Connect the Pod 1 E5382A Flying Lead Probe Set's bits 6 and 14 to the SMA/Flying Lead test connector's pin strip connector at the 8133A pulse generator's Channel 2 OUTPUT.
 - c Connect the Pod 1 E5382A Flying Lead Probe Set's bits 2 and 10 to the SMA/Flying Lead test connector's pin strip connector at the 8133A pulse generator's Channel 2 OUTPUT.
- 2 On the 8133A pulse generator, in the PULSE setup for CHANNEL 2, press the COMP button to return the outputs to normal.
- 3 Note that the signal on the oscilloscope has moved. Change the oscilloscope's horizontal position to 450 ps (or as required) to center the measured pulse on the oscilloscope display.

NOTE:

You can temporarily reduce the frequency on the pulse generator and increase the horizontal scale on the oscilloscope to verify that you are measuring the correct pulse. Then return the settings to normal.

- 4 Verify the DC offset and adjust it if necessary. See page 36.
- 5 Set the frequency of the pulse generator. The logic analyzer will be tested using a double-edge clock. The test frequency is half the test clock rate because data is acquired on both the rising edge and the falling edge of the clock. Set the frequency to 625 MHz plus the frequency uncertainty of the pulse generator, plus a test margin of 1%.

For example, if you are using an 8133A pulse generator, the frequency accuracy is $\pm 1\%$ of setting. Use a test margin of 1%. Set the frequency to 625 MHz plus 2% (638 MHz).

- 6 Verify the oscilloscope Deskew and adjust if necessary. See page 37.
- 7 Adjust the measured pulse width from the pulse generator to 750 ps (minus the test margin) as described on page 99.
- 8 Change the logic analyzer configuration:
 - a In the logic analyzer “Setup and Trigger...” window, select the Sampling tab. In the “State Mode Controls” section, select the “1250 Mb/s / 128M Half Chan” mode. The clock mode will change to “Both Edges”.
 - b In the logic analyzer’s Setup and Trigger window, Format tab, unassign all pod 2 bits. The channel assignment dialog looks different in half-channel mode because only half of the channels can be assigned now.
 - c Assign bits 2, 6, 10, and 14 of Pod 1.
 - d Verify that the Pod 1 threshold is set to 1 volt. See page 82.
 - e In the “Setup and Trigger...” window, Format tab, verify that the J clock threshold is still set to Differential.
 - f Re-establish the trigger function:
 - i In the logic analyzer’s Setup and Trigger window, select the Trigger tab, and the Trigger Functions subtab.
 - ii Select “Find pattern n times” and select the “Replace” button.
 - iii Enter “A” in the “Label 1 = “ field.

9 Adjust sampling positions using *eye finder*:

In the 1250 Mb/s mode, only double-edge clocking (“Both Edges”) is available. Therefore, we will use a different method for ensuring that we are measuring the correct eye.

- a** Set the pulse generator frequency to half of the required value. If it was set to 638 MHz, then temporarily set it to 319 MHz.
- b** In the *eye finder* (Sampling Positions) window, expand “Label1 (4 channels)”.
- c** Grab the blue bar for “Label1 (4 Channels)” and move it to approximately -0.94 ns. All blue bars will follow.
- d** Click “Run Eye Finder” and note the average sampling position chosen by *eye finder*: _____ ns. Note that in this step, you place the blue bars in the first narrow window (not the wide window) that appears to the left of zero in the *eye finder* display. Then run *eye finder*.

In the following example, the average sampling position is -0.94 ns. The position may be different based on your test setup.

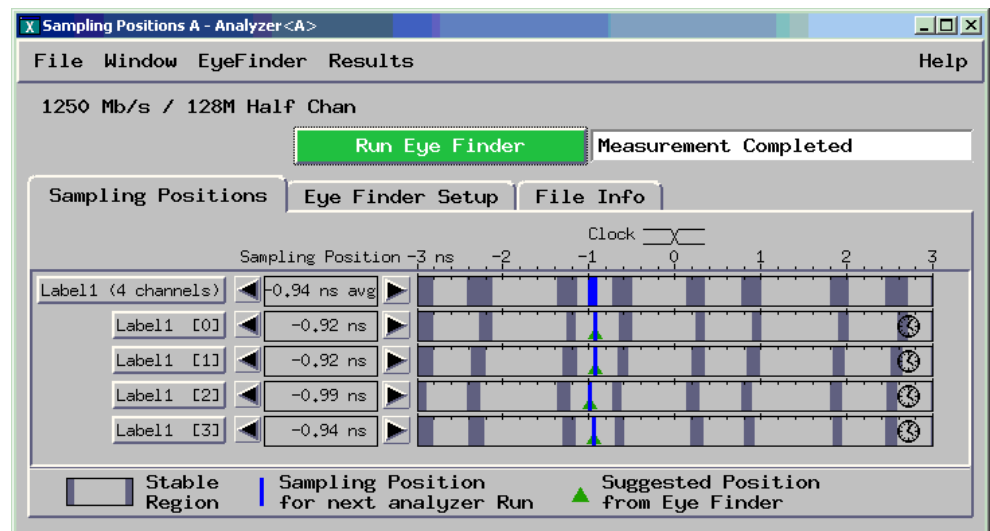

- e** Bring stray channels into alignment if necessary. See page 86.
- f** Re-set the pulse generator frequency to 625 MHz plus the test margin (638 MHz).
- g** In the *eye finder* window, align the blue bars vertically. See page 84.
- h** Grab the blue bar for “Label1 (4 Channels)” and move it to the recommended starting position you noted in the prior step.

- i** Click “Run Eye Finder” again. Some eyes may close, but the eyes in the sampling position you chose on page 107 should remain open. Re-align stray blue bars if necessary. See page 86.

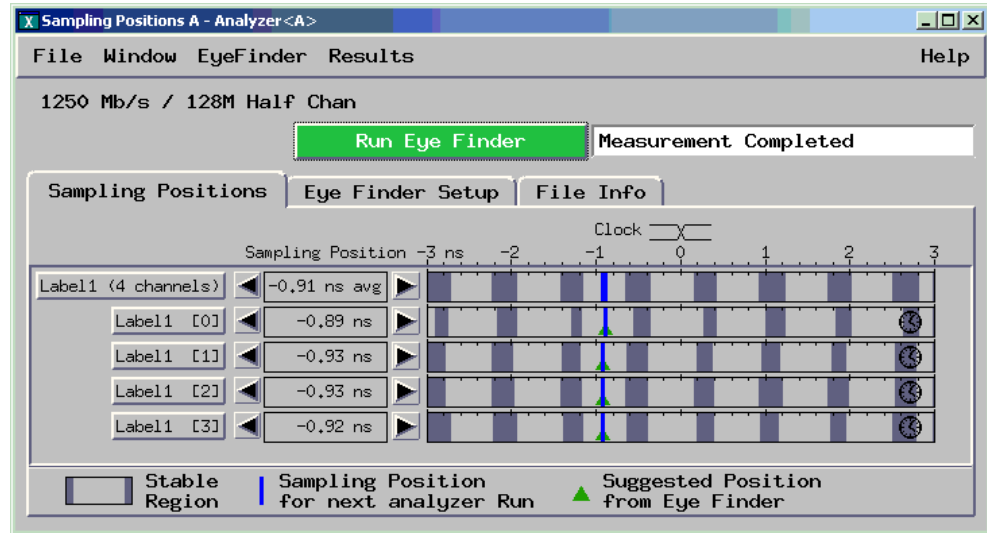

- 10** Perform the procedure “Determine PASS/FAIL (1 of 2 tests):” on page 87.
- 11** Select the Run Repetitive icon in the Listing window.
- 12** Perform the procedure “Determine PASS/FAIL (2 of 2 tests):” on page 89.
- 13** Test the complement of the bits:
 - a** On the 8133A pulse generator, in the PULSE setup for CHANNEL 2, select COMP.
 - b** Note that the signal on the oscilloscope has moved. Change the oscilloscope’s horizontal position to -300 ps (or as required) to center the measured pulse on the oscilloscope display.
 - c** Verify the DC offset and adjust it if necessary. See page 36.
 - d** Deskew the oscilloscope. See page 37.
 - e** Adjust the measured pulse width from the pulse generator to 750 ps (minus the test margin) as described on page 99.
 - f** Run *eye finder*.
 - g** Perform the procedure “Determine PASS/FAIL (1 of 2 tests):” on page 87.
 - h** Select the Run Repetitive icon in the Listing window.

- i** Perform the procedure “Determine PASS/FAIL (2 of 2 tests):” on page 89.

Test Pod 2 in 1250 Mb/s mode

- 1** Change test equipment connections:
 - a** Leave the first E5382A Flying Lead Probe Set connected to Pod 1 of the logic analyzer. Remove the Pod 1 flying leads 2, 6, 10, and 14 from the SMA/Flying Lead test connectors. Do not remove the flying leads that are connected to CLK and $\overline{\text{CLK}}$ flying leads.
 - b** Connect the Pod 2 E5382A Flying Lead Probe Set’s bits 6 and 14 to the SMA/Flying Lead test connector’s pin strip connector at the 8133A pulse generator’s Channel 2 OUTPUT.
 - c** Connect the Pod 2 E5382A Flying Lead Probe Set’s bits 2 and 10 to the SMA/Flying Lead test connector’s pin strip connector at the 8133A pulse generator’s Channel 2 $\overline{\text{OUTPUT}}$.
- 2** On the 8133A pulse generator, in the PULSE setup for CHANNEL 2, press the COMP button to return the outputs to normal.
- 3** Note that the signal on the oscilloscope has moved. Change the oscilloscope’s horizontal position to 450 ps (or as required) to center the measured pulse on the oscilloscope display.
- 4** Verify the DC offset and adjust it if necessary. See page 36.
- 5** Deskew the oscilloscope if necessary. See page 37.
- 6** Adjust the measured pulse width from the pulse generator to 750 ps (minus the test margin) as described on page 99.
- 7** Change the logic analyzer configuration:
 - a** In the logic analyzer’s Setup and Trigger window, Format tab, unassign all pod 1 bits.
 - b** Assign bits 2, 6, 10, and 14 of Pod 2.
 - c** Verify that the Pod 2 threshold is set to 1 volt (just as you did for Pod 1 on page 82).
 - d** In the “Setup and Trigger...” window, Format tab, use the scroll bar at the bottom of the window to scroll to the left. Verify that the J clock threshold is set to Differential.

- e** Re-establish the trigger function:
 - i** In the logic analyzer's Setup and Trigger window, select the Trigger tab, and the Trigger Functions subtab.
 - ii** Select "Find pattern n times" and select the "Replace" button.
 - iii** Enter "A" in the "Label 1 = " field.
- 8** Adjust the sampling positions using *eye finder*. Be sure to expand "Label1 (4 channels)". You can use the starting position you noted on page 107. Re-align any stray channels if necessary. See page 86.
- 9** Determine pass or fail (1 of 2 tests). See page 87.
- 10** Ensure that the Listing window is set up. See page 87.
- 11** Select the Run Repetitive icon in the Listing window.
- 12** Determine pass or fail (2 of 2 tests). See page 89.
- 13** Test the complement of the bits on Pod 2. You can use the procedure "Test the complement of the bits:" on page 108 as a guideline.

Test Pod 1 in 1500 Mb/s mode

- 1** Change test equipment connections:
 - a** Disconnect the Pod 2 E5382A Flying Lead Probe Set's bits 2, 6, 10, and 14 from the SMA/Flying Lead test connectors' pin strip connectors.

The original E5382A Flying Lead Probe Set should still be connected to Pod 1. The J clock on Pod 1 will be used for all tests.
 - b** Connect the Pod 1 E5382A Flying Lead Probe Set's bits 6 and 14 to the SMA/Flying Lead test connector's pin strip connector at the 8133A pulse generator's Channel 2 OUTPUT.
 - c** Connect the Pod 1 E5382A Flying Lead Probe Set's bits 2 and 10 to the SMA/Flying Lead test connector's pin strip connector at the 8133A pulse generator's Channel 2 OUTPUT.
- 2** On the 8133A pulse generator, in the PULSE setup for CHANNEL 2, press the COMP button to return the outputs to normal.
- 3** Note that the signal on the oscilloscope has moved. Change the oscilloscope's horizontal position to 450 ps (or as required) to center the measured pulse on the oscilloscope display.

NOTE:

You can temporarily reduce the frequency on the pulse generator and increase the horizontal scale on the oscilloscope to verify that you are measuring the correct pulse. Then return the settings to normal.

- 4 Verify the DC offset and adjust it if necessary. See page 36.
- 5 Set the frequency of the pulse generator. The logic analyzer will be tested using a double-edge clock. The test frequency is half the test clock rate because data is acquired on both the rising edge and the falling edge of the clock. Set the frequency to 750 MHz plus the frequency uncertainty of the pulse generator, plus a test margin of 1%.

For example, if you are using an 8133A pulse generator, the frequency accuracy is $\pm 1\%$ of setting. Use a test margin of 1%. Set the frequency to 750 MHz plus 2% (765 MHz).

- 6 Verify the oscilloscope Deskew and adjust if necessary. See page 37.
- 7 Adjust the measured pulse width to 600 ps:

In this procedure, you will use the oscilloscope's measurement markers to measure the actual pulse width in the test setup. Then you will adjust the pulse generator so that the measured pulse width is as specified.

- a Observe the 54845A oscilloscope display. Change the Channel 2 pulse width of the 8133A pulse generator so that the pulse width measured at 1 volt on the oscilloscope is equal to 600 ps minus the measurement uncertainty and display resolution of the oscilloscope, further reduced by 35 ps for test margin.

For example, if you are using the 54845A/B oscilloscope, the measurement uncertainty is $\pm((0.007\% * \Delta t) + (\text{full scale}/2\text{x memory depth}) + 30 \text{ ps}) \cong \pm 30 \text{ ps}$. Add 5 ps for display resolution. Add 35 ps test margin.

$$600 \text{ ps} - 30 \text{ ps} - 5 \text{ ps} - 35 \text{ ps} = 530 \text{ ps}$$

Therefore, set the pulse width as measured on the 54845A/B oscilloscope to 530 ps.

- b In the oscilloscope horizontal setup, change the position to 300 ps (or as required) to center the pulse on the display.

- c On the oscilloscope, move the Ax and Bx markers to the crossing points of the pulse and the horizontal center line. Read the pulse width at the bottom of the oscilloscope display. It is displayed as “ Δ ”.

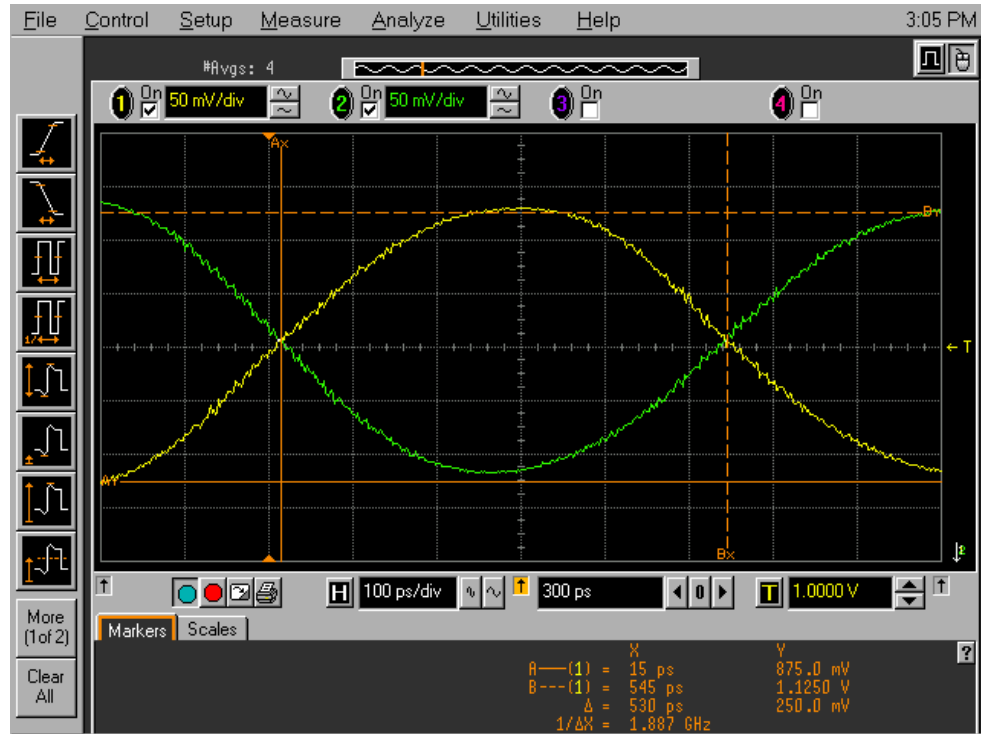

8 Change the logic analyzer configuration:

- a In the logic analyzer “Setup and Trigger...” window, select the Sampling tab. In the “State Mode Controls” section, select the “1500 Mb/s / 128M Half Chan” mode.
- b In the logic analyzer’s Setup and Trigger window, Format tab, unassign all pod 2 bits.
- c Assign bits 2, 6, 10, and 14 of Pod 1.
- d Ensure that the Pod 1 threshold is set to 1 volt. See page 82.
- e In the “Setup and Trigger...” window, Format tab, ensure that the J clock threshold is still set to Differential.
- f Re-establish the trigger function:
 - i In the logic analyzer’s Setup and Trigger window, select the Trigger tab, and the Trigger Functions subtab.
 - ii Select “Find pattern n times” and select the “Replace” button.

iii Enter “A” in the “Label 1 = “ field.

9 Adjust sampling positions using *eye finder*:

- a Set the pulse generator frequency to half of the required value. If it was set to 765 MHz, then temporarily set it to 383 MHz.
- b In the *eye finder* (Sampling Positions) window, expand “Label1 (4 channels)”.
- c Grab the blue bar for “Label1 (4 Channels)” and move it to approximately 3.1 ns. All blue bars will follow.
- d Click “Run Eye Finder” and note the average sampling position chosen by *eye finder*:_____ns. Note that in this step, you place the blue bars in the last complete narrow window that appears on the right in the *eye finder* display. Then run *eye finder*.

In the following example, the average sampling position is 3.10 ns. The position may be different based on your test setup.

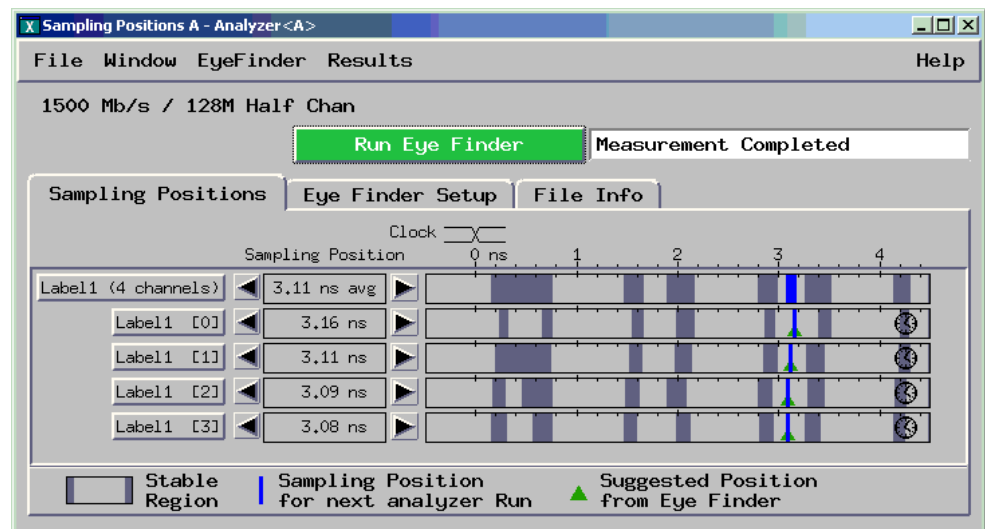

- e Bring stray channels into alignment if necessary. See page 86.
- f Re-set the pulse generator frequency to 750 MHz plus the test margin (765 MHz).
- g In the *eye finder* window, align the blue bars vertically. See page 84.
- h Grab the blue bar for “Label1 (4 Channels)” and move it to the recommended starting position you noted in the prior step.

- i** Click “Run Eye Finder” again. Some eyes may close, but the eyes in the sampling position you chose on page 113 should remain open. Re-align stray blue bars if necessary. See page 86.

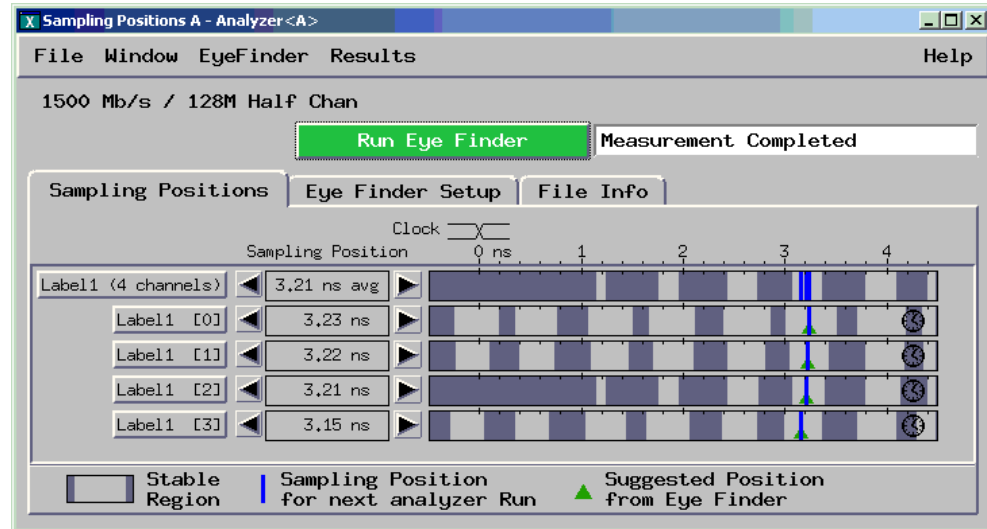

- 10** Perform the procedure “Determine PASS/FAIL (1 of 2 tests):” on page 87.
- 11** Select the Run Repetitive icon in the Listing window.
- 12** Perform the procedure “Determine PASS/FAIL (2 of 2 tests):” on page 89.
- 13** Test the complement of the bits:
 - a** On the 8133A pulse generator, in the PULSE setup for CHANNEL 2, select COMP.
 - b** Note that the signal on the oscilloscope has moved. Change the oscilloscope’s horizontal position to -350 ps (or as required) to center the measured pulse on the oscilloscope display.
 - c** Verify the DC offset and adjust it if necessary. See page 36.
 - d** Deskew the oscilloscope. See page 37.
 - e** Verify that the pulse width is set to 600 ps. See page 111.
 - f** Run *eye finder*.
 - g** Perform the procedure “Determine PASS/FAIL (1 of 2 tests):” on page 87.
 - h** Select the Run Repetitive icon in the Listing window.

- i** Perform the procedure “Determine PASS/FAIL (2 of 2 tests):” on page 89.

Test Pod 2 in 1500 Mb/s mode

- 1** Change test equipment connections:
 - a** Leave the first E5382A Flying Lead Probe Set connected to Pod 1 of the logic analyzer. Remove the Pod 1 flying leads 2, 6, 10, and 14 from the SMA/Flying Lead test connectors. Do not remove the flying leads that are connected to CLK and $\overline{\text{CLK}}$ flying leads.
 - b** Connect the Pod 2 E5382A Flying Lead Probe Set’s bits 6 and 14 to the SMA/Flying Lead test connector’s pin strip connector at the 8133A pulse generator’s Channel 2 OUTPUT.
 - c** Connect the Pod 2 E5382A Flying Lead Probe Set’s bits 2 and 10 to the SMA/Flying Lead test connector’s pin strip connector at the 8133A pulse generator’s Channel 2 OUTPUT.
- 2** On the 8133A pulse generator, in the PULSE setup for CHANNEL 2, press the COMP button to return the outputs to normal.
- 3** Note that the signal on the oscilloscope has moved. Change the oscilloscope’s horizontal position to 300 ps (or as required) to center the measured pulse on the oscilloscope display.
- 4** Verify the DC offset and adjust it if necessary. See page 36.
- 5** Deskew the oscilloscope if necessary. See page 37.
- 6** Adjust the measured pulse width from the pulse generator to 600 ps (minus the test margin) as described on page 111.
- 7** Change the logic analyzer configuration:
 - a** In the logic analyzer’s Setup and Trigger window, Format tab, unassign all pod 1 bits.
 - b** Assign bits 2, 6, 10, and 14 of Pod 2.
 - c** Verify that the Pod 2 threshold is set to 1 volt (just as you did for Pod 1 on page 82).
 - d** In the “Setup and Trigger...” window, Format tab, use the scroll bar at the bottom of the window to scroll to the left. Ensure that the J clock threshold is set to Differential.

- e** Re-establish the trigger function:
 - i** In the logic analyzer's Setup and Trigger window, select the Trigger tab, and the Trigger Functions subtab.
 - ii** Select "Find pattern n times" and select the "Replace" button.
 - iii** Enter "A" in the "Label 1 = " field.
- 8** Adjust the sampling positions using *eye finder*. Be sure to expand "Label1 (4 channels)". You can use the starting position you noted on page 113. Re-align any stray channels if necessary. See page 86.
- 9** Determine pass or fail (1 of 2 tests). See page 87.
- 10** Ensure that the Listing window is set up. See page 87.
- 11** Select the Run Repetitive icon in the Listing window.
- 12** Determine pass or fail (2 of 2 tests). See page 89.
- 13** Test the complement of the bits on Pod 2. You can use the procedure "Test the complement of the bits:" on page 114 as a guideline.

Complete Multi-Card Module Testing

This section applies when cards were received as a multi-card module, and you have reconfigured them as single card modules for manual testing.

All single card modules must be reconfigured into their original multi-card module configuration upon completion of the “Manual Test Procedure, 16900-Series Mainframe” or “Manual Test Procedure, 16700-Series Mainframe”.

- 1** Turn off the mainframe and follow the procedures in “Preparing for Use,” beginning on page 15 to return the cards to their original configuration.
- 2** Then run the self-tests as described in “Run the Software (Self) Tests” on page 27.
- 3** Finally, complete the “Performance Test Record” on page 118.

The Performance Test Record is designed to be used with the equipment specified on page 22. If you are not using the recommended test equipment, you will need to create your own version of the Performance Test Record with parameters that are specific to your test equipment.

Performance Test Record

Performance Test Record

16760A Logic Analyzer	
Logic Analyzer Serial No.	Work Order No.
Date:	Recommended Test Interval - 2 Year/4000 hours
	Recommended next testing:

Test Equipment Used	
Pulse Generator Model No.	Oscilloscope Model No.
Pulse Generator Serial No.	Oscilloscope Serial No.
Pulse Generator Calibration Due Date:	Oscilloscope Calibration Due Date:

Measurement Uncertainty	
Clock Rate	Pulse Width (Eye Width)
Pulse Generator Frequency Accuracy: 8133A: 1% of setting Test Margin: 1%	Oscilloscope Horizontal Accuracy: 54845B: $\pm [(0.007\%) (\Delta t) + (\text{full scale}/(2 \times \text{memory depth})) + 30 \text{ ps}] \cong 30 \text{ ps}$ 54845A/B Oscilloscope Display Resolution: $\pm 5 \text{ ps}$ Test Margin: 35 ps. Sum: 70 ps
Setting: 200 MHz + 2% = 204 MHz (102 MHz double edge) 400 MHz + 2% = 408 MHz (204 MHz double edge) 800 MHz + 2% = 816 MHz (408 MHz double edge) 1250 MHz + 2% = 1275 MHz (638 MHz double edge) 1500 MHz + 2% = 1530 MHz (765 MHz double edge)	Pulse Width setting: 1.5 ns - 70 ps = 1430 ps Pulse Width setting: 1.5 ns - 70 ps = 1430 ps Pulse Width setting: 750 ps - 70 ps = 680 ps Pulse Width setting: 750 ps - 70 ps = 680 ps Pulse Width setting: 600 ps - 70 ps = 530 ps

Tests			
Test	Settings	Pass/Fail Results	
		1 of 2:	2 of 2:
Initial Self-Tests	n/a		
200 Mb/s mode	Minimum clock interval, min. eye width		
400 Mb/s mode	Minimum clock interval, min. eye width		
800 Mb/s mode	Minimum clock interval, min. eye width		
1250 Mb/s mode	Minimum clock interval, min. eye width		
1500 Mb/s mode	Minimum clock interval, min. eye width		
Multi-card module self test	n/a		

Calibrating

This chapter gives you instructions for calibrating the logic analyzer.

Calibration Strategy

The 16760A logic analyzer does not require an operational accuracy calibration. To test the module against the module specifications, refer to Chapter 3, “Testing Performance,” beginning on page 19.

Troubleshooting

This chapter helps you troubleshoot the module to find defective assemblies.

The troubleshooting consists of flowcharts, self-test instructions, a cable test, and a test for the auxiliary power supplied by the probe cable.

If you suspect a problem, start at the top of the first flowchart. During the troubleshooting instructions, the flowcharts will direct you to perform the self-tests or the cable test.

The service strategy for this instrument is the replacement of defective assemblies. This module can be returned to Agilent Technologies for all service work, including troubleshooting. Contact your nearest Agilent Technologies Sales Office for more details.

CAUTION:

Electrostatic discharge can damage electronic components. Use grounded wrist-straps and mats when you perform any service to this instrument or to the cards in it.

To use the flowcharts

Flowcharts are the primary tool used to isolate defective assemblies. The flowcharts refer to other tests to help isolate the trouble. The circled numbers on the charts indicate connections with the other flowcharts. Start your troubleshooting at the top of the first flowchart.

Mainframe Operating System

Before troubleshooting a 16760A logic analyzer module, ensure that the required logic analysis system software version is installed on the mainframe. The required software versions are listed in “Mainframe and Operating System” on page 10.

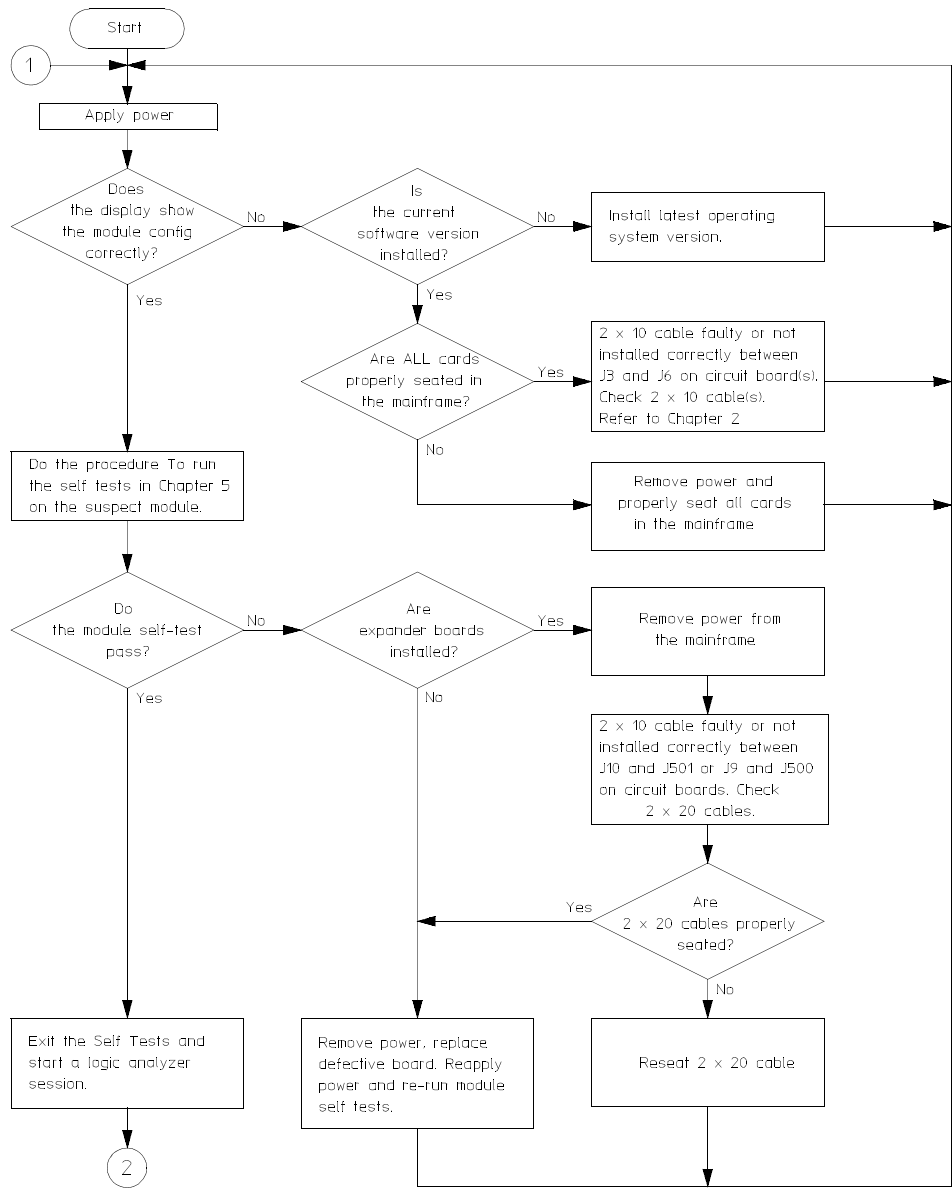

16740b03

Troubleshooting Flowchart 1

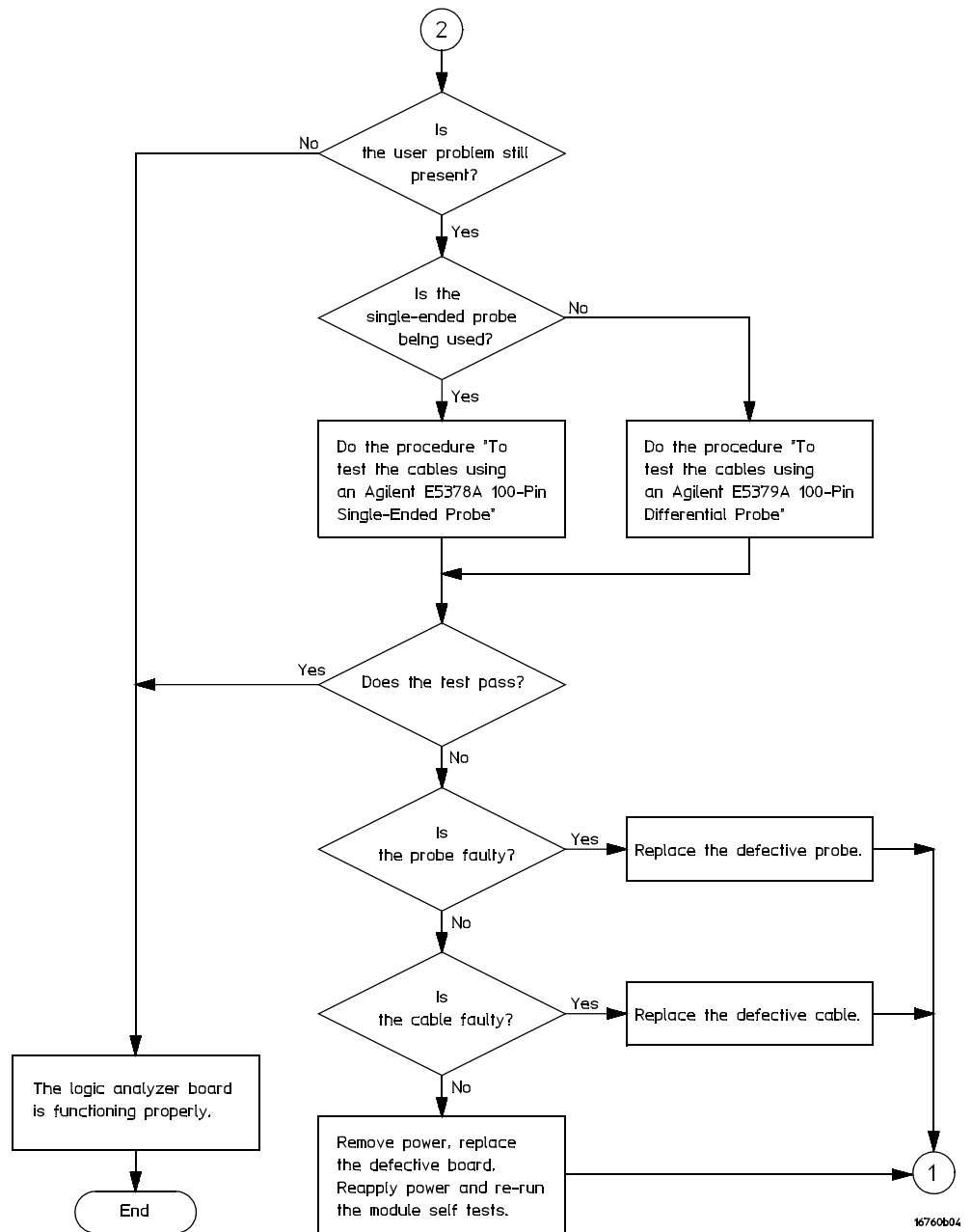

Troubleshooting Flowchart 2

16760b04

To run the self-tests

On a 16900-Series Mainframe

- 1 See Run the Software (Self) Tests “On a 16900-Series Mainframe” on page 27.

On a 16700-Series Mainframe

Self-tests identify the correct operation of major, functional subsystems of the module. You can run all self-tests without accessing the module. If a self-test fails, the troubleshooting flowcharts instruct you to change a part of the module.

To run the self-tests:

- 1 In the System window, select the System Administration icon.
- 2 In the System Administration window, select the Admin tab, then select Self-Test. At the Test Query window, select Yes.

The tests can be run individually, or all the tests can be run by selecting Test All at the bottom of the Self Test window. Note that if Test All is selected, system tests requiring user action will not be run. See the “Agilent Technologies 16700B/16702B Logic Analysis System and 16701B Expansion Frame Service Guide” for more information about the mainframe self-tests. Module self-tests are described on page 126.

- 3 In the Self Test window under the System tab, select System CPU Board.
- 4 Run the floppy drive test.
 - a In the Self Test: System CPU Board window, select Floppy Drive Test.
 - b Insert a DOS-formatted disk with 300KB of available space in the mainframe floppy drive.
 - c In the Test Query window, select OK.

The Test Query window instructs you to insert the disk into the disk drive. The other System CPU Board tests require similar user action to successfully run the test.

- 5 In the Self Test: System CPU Board window, select Close to close the window.

- 6 In the Self Test window, select PCI Board. Select Test All to run all PCI board tests.

In the Self Test window, select the Master Frame tab. Select the 16760A module to be tested, then select Test All to run all the module tests. The module test status should indicate PASSED (see screen on next page).

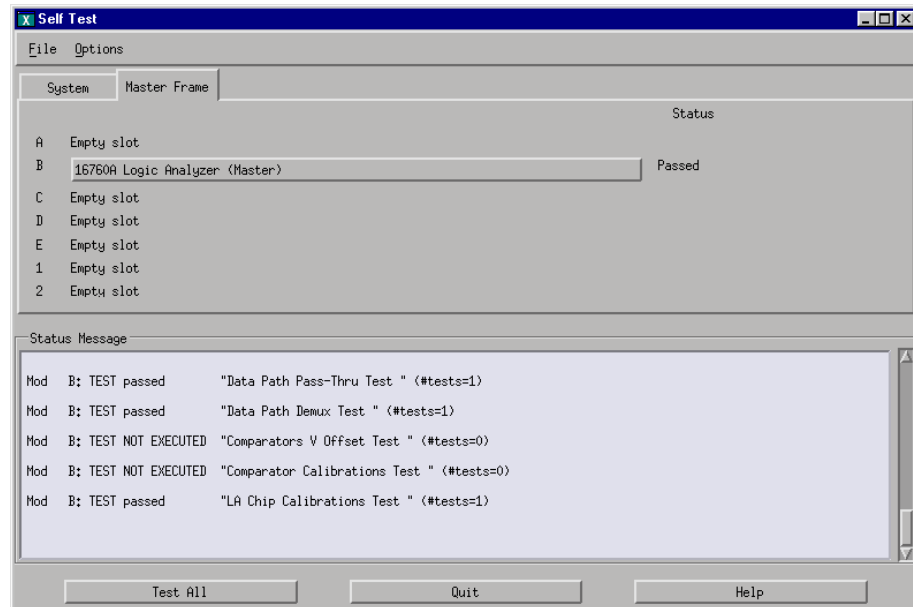

Self-Test Descriptions

The self-tests for the logic analyzer identify the correct operation of major functional areas in the module.

CPLD Register Test. The CPLD Register Test verifies that the mainframe backplane can communicate with the 16760A module CPLD. The CPLD is used to configure the backplane and the memory devices. The test is done using both a walking “1” and walking “0” pattern. After the pattern has been stepped, internal device registers are read.

Passing the CPLD Registers Test implies that the module backplane device can be properly configured for module setup and data download.

Load FPGA Test. The Load FPGA Test verifies that the backplane interface device and the data memory control device can be configured. Configuration data is read from a file. During the configuration process, status signals are checked to verify the 16760A module hardware is operating properly during the configuration upload.

Passing the Load FPGA Test implies that the module can be properly configured for normal operation.

FPGA Register Test. The FPGA Register Test verifies that the read/write registers of the backplane interface device and the memory control device can be written to then read. Both a walking “1” and “0” pattern is written to the device registers. The registers are then read and compared with known values.

Passing the FPGA Registers Test implies that the module hardware configuration can be properly managed as part of normal module operation.

Memory Data Bus Test. The Memory Data Bus Test verifies the read/write access of the acquisition module from the system backplane. In addition, some of the operations of the acquisition memory and control are also tested. A walking “1” and “0” is written to the first memory location. The contents of the first memory location is then downloaded and compared with known values.

Passing the Memory Data Bus Test implies that data stored in the acquisition memory can be uploaded from the 16760A module to the system mainframe.

Memory Address Bus Test. The Memory Address Bus Test verifies the operation of the acquisition memory address bus. After initializing the acquisition memory, the address bus is exercised with a walking “1” and “0” pattern. At each resulting memory address, test data is stored. The test data is then downloaded and compared with known values.

Passing the Memory Address Bus Test implies that each signal line of the acquisition memory address bus is operational, and therefore all locations in the

acquisition memory can be accessed.

HW Assisted Memory Cell Test. After verifying the acquisition memory address bus signal lines using the Memory Address Bus Test, the HW Assisted Memory Cell Test does a read/write test on every location in the acquisition memory. Each location in acquisition memory is filled with a test data pattern. After loading acquisition memory, the test data at each memory location is downloaded then compared with known values.

Passing the HW Assisted Memory Cell Test implies that each location in acquisition memory can be accessed, written, read, and can properly store data.

Memory Unload Modes Test. The Memory Unload Modes Test verifies the CPU interface can properly manage the acquisition memory unload in both full-channel, half-channel, and interleaved modes. Test data is written to acquisition memory. Different unload modes are selected, then the data is read and compared with known values.

Passing the Memory Unload Modes Test implies that the data can be reliably read from acquisition memory in full-channel, half-channel, or interleaved mode. This test along with the Memory Data Bus Test and Memory Address Bus Test provide complete testing of acquisition memory downloading through the CPU interface.

Memory DMA Unload Test. The Memory DMA Unload Test performs the same functions as the Memory Unload Test, except DMA backplane transfers are used to read the data from acquisition memory.

Memory Sleep Mode Test. The Memory Sleep Mode Test verifies the self refresh mode of acquisition memory devices. Memory self refresh mode is enabled when the memory control device is reprogrammed during normal operation.

Passing the Memory Sleep Mode Test verifies the acquisition memory will retain data during changes in 16760A operating modes during normal operation.

HW Accelerated Search Test. The HW Accelerated Search Test verifies the fundamental search capabilities of the module. Acquisition RAM is loaded with test data, and the search registers in the gate arrays are programmed with test patterns. Basic search functions including return and count pattern, are done and monitored for success.

Passing the HW Accelerated Search Test implies that the module's fundamental Hardware accelerated pattern search capabilities are operating and that pattern searches and pattern occurrence counts can be performed.

Chip Registers Read/Write Test. The Chip Registers Read/Write Test verifies that the registers of each acquisition IC are operating properly. Test patterns are written to each register on each acquisition IC, read, and compared with known values. The registers are reset, and verified that each register has been initialized.

Test patterns are then written to ensure the chip address lines are not shorted or opened. Finally test data is written to registers of individual acquisition ICs to ensure each acquisition IC can be selected independently.

Passing the Chip Registers Read/Write Test implies that the acquisition IC registers can store acquisition control data to properly manage the operating of each IC.

Analyzer Chip Memory Bus Test. The Analyzer Chip Memory Bus Test verifies the operation of the acquisition memory buses between acquisition ICs. After initializing the memory a walking “1” and “0” pattern is created at the output of the acquisition ICs. This test data is stored in memory, read, and compared with known values.

Passing the Analyzer Chip Memory Bus Test implies that the acquisition memory buses between the acquisition ICs and acquisition memory is operating, and that acquisition data can propagate from the ICs to memory.

System Clocks (Master/Slave/Psync) Test. The System Clocks (Master/Slave/Psync) Test verifies the system clock are functional between all boards in a master/expander multi-card module. The module is configured for a simple measurement and test data is created. The test data is then downloaded and compared with known values.

Passing the System Clocks (Master/Slave/Psync) Test implies that the acquisition ICs of each expander board of a multi-card configuration can properly receive system clocks, and that all acquisition ICs in the multi-card module will properly capture data.

Analyzer Memory Bus SU/H Measure. The Analyzer Memory Bus SU/H Measure is an internal test that ensures the timing between the acquisition IC and acquisition memory is within acceptable parameters.

System Backplane Clock Test. The System Backplane Clock Test verifies the 100 MHz acquisition system clock. The test also ensures an on-board phase-locked loop can properly generate multiples of the acquisition system clock frequency. The 100 MHz acquisition system clock is first routed directly to the acquisition ICs. A timer is initialized, run, and stopped after 100ms. the counter is read, and compared with a known value. The acquisition system clock is then routed to the phase-locked loop to generate a frequency of 166.7 MHz. Again, the counter is initialized, run, and stopped after 100ms. The counter is read, and compared with a known value.

Passing the System Backplane Clock Test implies that the system acquisition clock is operating, and is within 5% of the desired acquisition frequency.

Inter-chip Resource Bus Test. The Inter-chip Resource Bus Test verifies the resource lines that run between each acquisition IC to ensure that the resource lines can be both driven as outputs and read as inputs. The resource registers are

written with test patterns, read back, then compared with known values. The resource registers are then written with test patterns, read back from a different acquisition IC, and then compared with known values.

Inter-module Flag Bits Test. Flag bits are used for module-to-module communication within the logic analysis system. The Inter-module Flag Bits Test verifies that the flag bit lines can be driven and received by each acquisition IC in each module. Test patterns are written to the flag registers, read by the other acquisition ICs in the other modules, and then compared with known values.

Passing the Inter-module Flag Bits Test implies that the acquisition ICs can communicate using Flag Bits through the CPU interface and the logic analysis system backplane, and that the operations utilizing the flag bits can be properly recognized by all modules in the system.

Global and Local Arm Lines Test. The Global and Local Arm Lines Test verifies that the local arm signal can be received by each acquisition IC on the master board. The test also verifies the global arm signal can be driven by each acquisition IC on a master board, and received by all acquisition ICs in the module on the master and on all expander boards. The arm lines are asserted and read at the acquisition ICs to ensure each acquisition IC recognizes the signal.

Passing the Global and Local Arm Lines Test implies any acquisition ICs on the master board can arm the module, and that all acquisition ICs can recognize the arm signal.

EEPROM Test. The EEPROM Test verifies the operation of the module EEPROM, which stores the operational accuracy calibration factors. The existing contents of the EEPROM are uploaded into system memory. The EEPROM is overwritten with test patterns to verify that each cell in the EEPROM can independently store a 1 or 0. After the test has completed the original contents of the EEPROM are restored and its checksum verified.

Passing the EEPROM Test implies that the current operational accuracy calibration factors can be stored and then retrieved for use by the module to optimize its performance.

ADC Test. The ADC Test verifies the operation on the module analog-to-digital convertor (ADC) used in the module operational accuracy calibration, probe adapter identification, and on-board temperature monitoring. The ADC has built-in test voltage channels which monitors three test voltages. The output of the channels is then compared with known values.

Passing the ADC Test implies that the analog-to-digital convertor is operating properly and that the data paths around the ADC can properly pass data.

Probe ID Read Test. The Probe ID Read Test verifies that the analog-to-digital convertor (ADC) tested above and the on-board digital-to-analog convertor are operating to read the probe adapter ID. Probe adapter identification is done using

a precision resistor. When the probe adapter is installed onto the probe cable, the precision resistor completes a voltage divider network. The Probe ID Read Test exercises the voltage divider network and then reads the voltage across the precision resistor and compares the voltage to known values.

Passing the Probe ID Read Test implies that any of the compatible probe adapters can be properly identified, causing the module to configure itself correctly.

Demux Data Arrays Programming Test. The Demux Data Arrays Programming Test verifies that the gate arrays' programming bits can be properly configured. Various test patterns are written to the programming port of the gate arrays, then read back and compared to expected values.

Passing the Demux Data Arrays Programming Test implied that the gate arrays can be programmed according to the operating mode of the module.

Comparators Programming Test. The Comparators Programming Test verifies that the comparators' programming bits can be properly configured. Various test patterns are written to the programming port of each comparator, then read back and compared to expected values.

Passing the Comparators Programming Test implies that the comparators can be programmed according to the operating mode of the module.

Data Path Pass-Thru Test. The Data Path Pass-Thru Test ensures that incoming data can flow correctly between the comparators and the acquisition ICs. The gate arrays are programmed for low-speed acquisition, which makes them invisible to data. The comparators are configured in test mode to drive a toggling signal on one of the comparator outputs while all other outputs are held quiet. The activity detectors in the acquisition ICs are monitored to verify that only the expected signal is toggling. The test is repeated for each comparator output.

Passing the Data Path Pass-Thru Test implies that incoming data can flow from the module front end to the acquisition ICs without errors for low speed acquisition modes (Timing, 200 MHz State, and 400 MHz State acquisition modes).

Data Path Demux Test. The Data Path Demux Test operates the same as the Data Path Pass-Thru Test, except the gate arrays are programmed for high-speed acquisition where the incoming data is demultiplexed to improve throughput.

Passing the Data Path Demux Test implies that incoming data can flow from the module front end to the acquisition ICs without errors for high speed acquisition modes (800 MHz State and 1250 Mb/s State acquisition modes).

Comparators V Offset Test. The Comparators V Offset Test completes the operation check of the comparators. Voltage offset is programmed into the comparators to ensure proper signal symmetry of the differential signal with

respect to a threshold. The test verifies that the voltage offset can be programmed at all points throughout the offset range.

Passing the Comparators V Offset Test implies that the comparator voltage offset is programmable to ensure differential data signals are properly captured.

Comparators Calibration Test. The Comparators Calibration Test runs the comparator calibration to optimize the performance of the module. Both analog and digital domain tests are run to optimize signal integrity in the module front end.

Passing the Comparators Calibration Test implies that the comparators are completely operational and can be performance optimized. Note that the resulting calibration factors are not stored.

LA Chip Calibration Test. The LA Chip Calibration Test ensures that each acquisition IC in the module can perform an operational accuracy self-calibration every time Run is selected. The module is set in various configurations, after which the self-calibration routing is initiated. The results of the self-calibration is then checked to see if self-calibration was successful.

Passing the LA Chip Calibration Test implies that the module can reliably perform an operation accuracy self-calibration every time Run is selected. Consequently the incoming data is optimized to reduce channel-to-channel skew so the acquisition ICs can reliably capture the incoming data.

To exit the test system

On a 16900-Series Mainframe

- 1 Simply close the self-test window. No additional actions are required.
-

On a 16700-Series Mainframe

- 1 Select Close to close any module or system test windows.
- 2 In the Self Test window, select Quit.
- 3 In the session manager window, select Start Session to launch a new logic analyzer session.

To test the cables using an E5378A single-ended probe

On a 16900-Series Mainframe

This test allows you to functionally verify the logic analyzer cable and an Agilent E5378A probe.

Equipment Required

Equipment	Critical Specification	Recommended Part
Stimulus Board	No Substitute	16760-60001

- 1** Connect the logic analyzer to the stimulus board:
 - a** Connect an Agilent E5378A 100-pin single-ended probe to the logic analyzer module. Connect logic analyzer Pod 1 to the probe output marked “Odd.” Connect logic analyzer Pod 2 to the probe output marked “Even.”
 - b** Connect the probe input to stimulus board connector Pod 3 (J3, 800 Mb/s, full speed clock).
 - c** Connect a power cord to the stimulus board power supply. Connect the stimulus board power supply output to the stimulus board power supply connector J82.

- d** Plug in the stimulus power supply into line power. The green LED DS1 should illuminate showing that the stimulus board is active

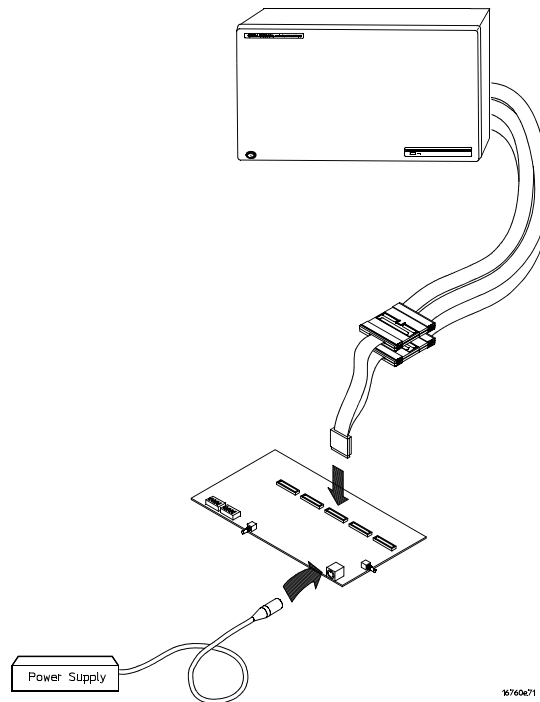

2 Set up the stimulus board:

- a** Configure the oscillator select switch, S1, for an internal 500 MHz clock according to the following settings:
- S1 = 0
 - S2 = 1
 - S3 = 0
 - Int
- b** Configure the data mode switch, S4, according to the following settings:
- Even
 - Count
- c** Press the Resynch VCO button; then, press the Counter RST (Counter Reset) button.

- 3 In the *Agilent Logic Analyzer* application, choose “File>New” to put the logic analysis system into its initial state.
- 4 Set up the logic analyzer’s sampling mode and options:
 - a Click the  Sampling Setup icon.
 - b Select the “State - Synchronous Sampling” Acquisition mode.
 - c Set the Trigger Position to “100% poststore”.
 - d Set the Acquisition Depth to “8K”.
 - e Select the “800 Mb/s” Sampling Option.
 - f Make sure the Clock Mode is “Periodic”.
 - g Select “Rising Edge” for Pod1 Clk1.

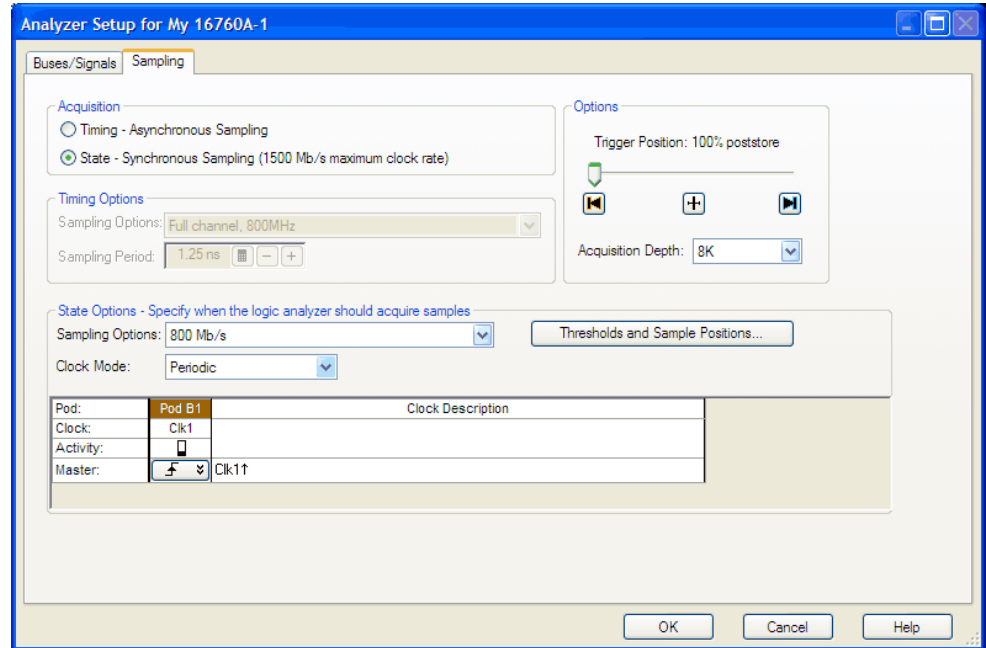

- h Click “OK” to close the Analyzer Setup dialog.
- 5 Set up threshold voltages:
 - a Click the  Bus/Signal Setup icon.
 - b In the Analyzer Setup dialog’s Buses/Signals tab, click the Threshold button for Pod 1.



- c** In the Threshold Settings dialog, set the threshold value for Pod 1 of the 16760A logic analyzer to “1 V”. Also, check “Apply setting to all pods” to properly set the threshold voltage for Pod 2, and uncheck “Apply settings to clock bits” (because the clock input threshold will be set to “differential” in a later step).

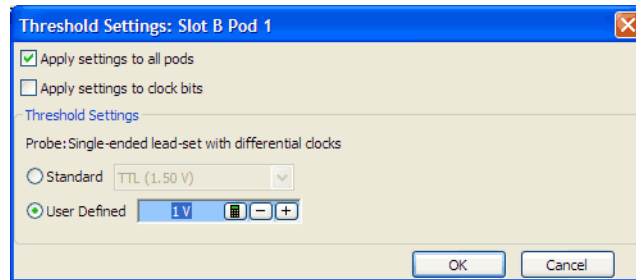

- d** Click “OK” to close the Threshold Settings dialog.

Now, in the Buses/Signals tab of the Analyzer Setup dialog, the activity indicators for Pod 1 show activity.

- e** Click the “Clock” (Cl) threshold button.



- f** In the Threshold Settings - Clocks dialog, click the threshold button associated with the Pod 1 clock.

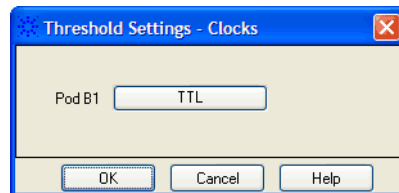

- g** In the Threshold Settings for Pod 1 dialog, select “Differential”.

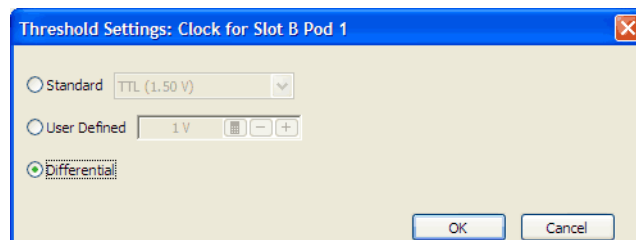

- h** Click “OK” to close the Threshold Settings dialogs.

Now, in the Buses/Signals tab of the Analyzer Setup dialog, the activity indicator for the Pod 1 clock shows activity.

- 6 Set up a bus for the pod's channels:
 - a Click the  Bus/Signal Setup icon.
 - b In the Analyzer Setup dialog's Buses/Signals tab, assign all Pod 1 channels to the bus name "My Bus 1".

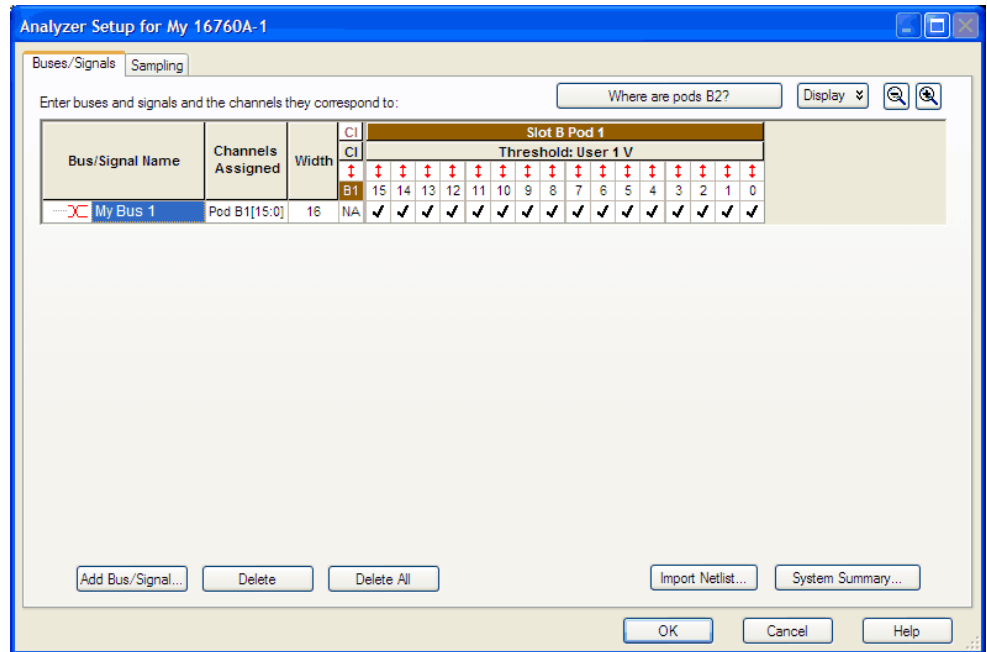

- c Click "OK" to close the Analyzer Setup dialog.
- 7 Adjust sampling positions using *eye finder*:
 - a Click the  Sampling Setup icon.
 - b In the Analyzer Setup dialog's Sampling tab, click "Thresholds and Sample Positions...".
 - c In the Thresholds and Sample Positions dialog, expand the "My Bus 1" bus name so you can see the individual signals in the bus.

- d** Click “Run” (the green button in the lower left-hand corner of the dialog). If any sample positions (blue bars) are in the wrong eye, drag the blue bars into the correct eye, and click “Run” again.

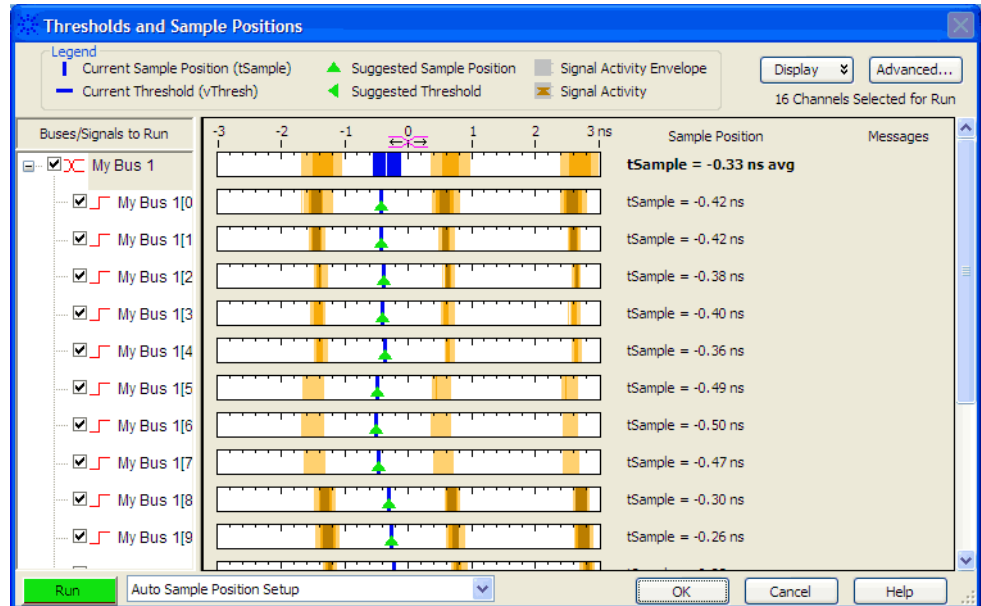

- e** Click “OK” to close the Thresholds and Sample Positions dialog, and click “OK” to close the Analyzer Setup dialog.
- 8** Acquire and verify data:
- a** In the Listing window, set up the logic analyzer to trigger My Bus 1 value “0000”.
- b** Click the  Run icon.

The listing should look similar to:

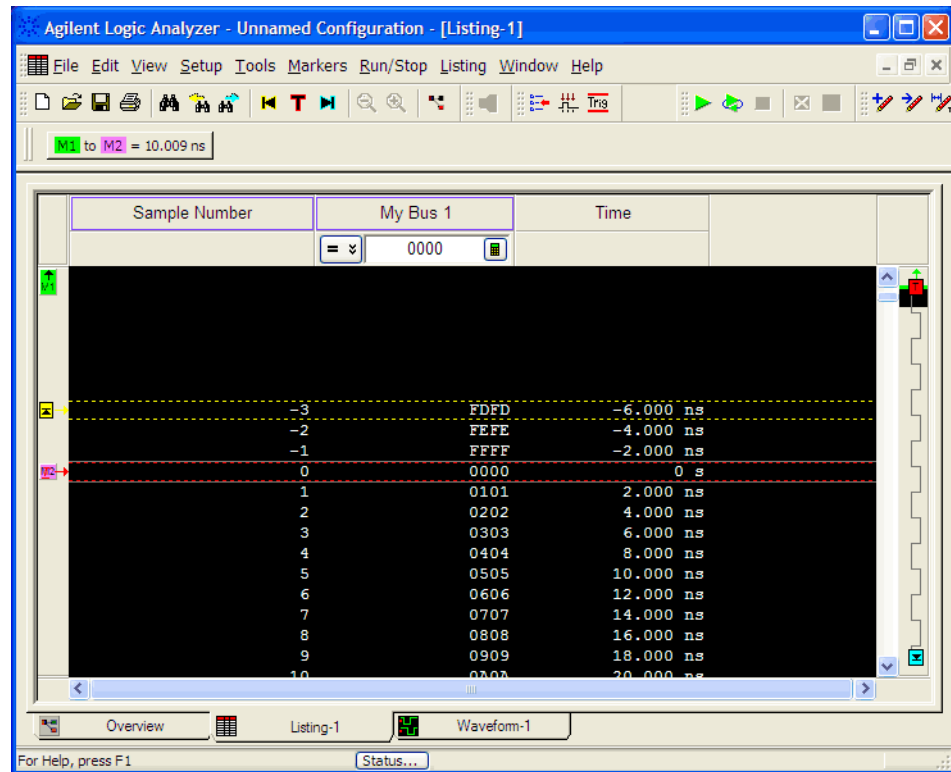

- c Scroll down at least 256 states to verify the data.

The My Bus 1 data shows two incrementing binary counters.

If the listing does not look similar the figure, there is a possible problem with the cable or high density adapter. Causes for cable test failure include:

- Open channel.
- Channel shorted to a neighboring channel.
- Channel shorted to either ground or a supply voltage.

- 9 If the test data is not correct, isolate the failure:

- a Reconnect probe adapter to the logic analyzer. Connect logic analyzer Pod 1 to the probe adapter output marked “Even.” Connect logic analyzer Pod 2 to the probe adapter output marked “Odd.”

- b Click the  Run icon.

The My Bus 1 data shows two decrementing binary counters.

- c Scroll down at least 256 states to verify the data.

If errors in the test data remain, suspect the logic analyzer cable.

If the errors are gone, suspect the E5378A probe adapter. Reconnect the logic analyzer Pod 1 cable to the “Odd” connector on the probe adapter, and connect the Pod 2 cable to the “Even” connector. Then, continue with the remaining steps to test the Pod 2 cable.

10 Change the logic analyzer pod assignment to use Pod 2:

a Choose “Setup>(logic analyzer module name)>Pod Assignment...”.

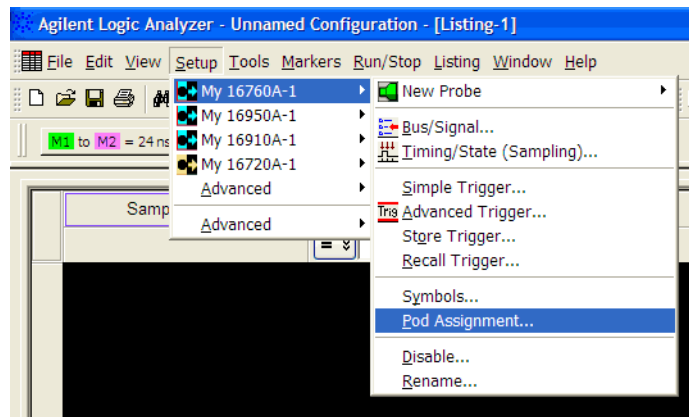

b In the Pod Assignment dialog, select “Reserved for time tag storage” for Pod 1 and the logic analyzer module name for Pod 2.

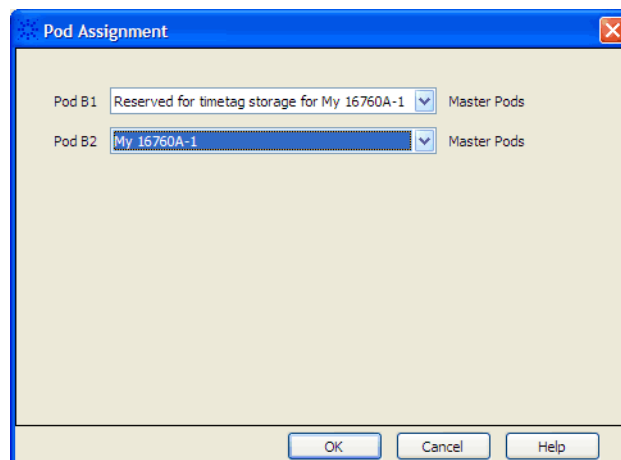

c Click “OK” to close the Pod Assignment dialog.

11 Set up a bus for the pod's channels:

- a** Click the  Bus/Signal Setup icon.
- b** In the Analyzer Setup dialog's Buses/Signals tab, assign all Pod 2 channels to the bus name "My Bus 1".

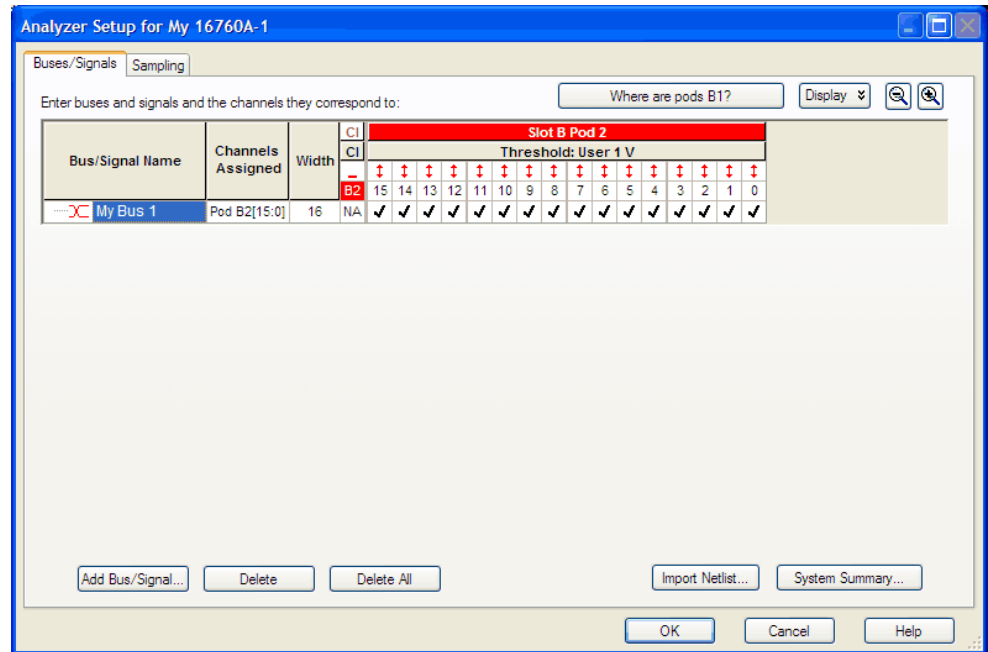

c Click "OK" to close the Analyzer Setup dialog.

12 Adjust sampling positions using *eye finder*:

- a** Click the  Sampling Setup icon.
- b** In the Analyzer Setup dialog's Sampling tab, click "Thresholds and Sample Positions...".
- c** In the Thresholds and Sample Positions dialog, expand the "My Bus 1" bus name so you can see the individual signals in the bus.

- d** Click “Run” (the green button in the lower left-hand corner of the dialog). If any sample positions (blue bars) are in the wrong eye, drag the blue bars into the correct eye, and click “Run” again.

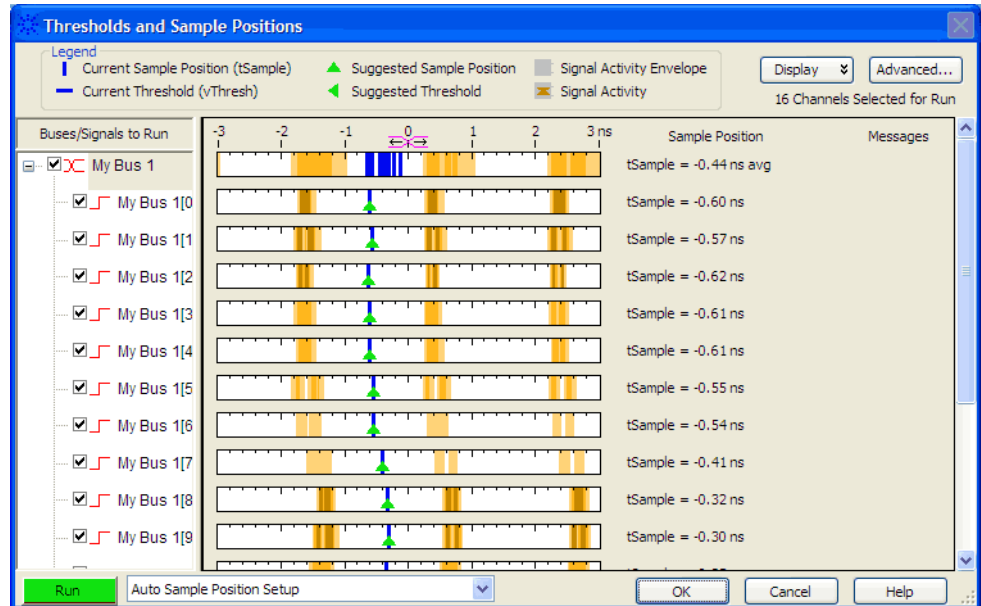

- e** Click “OK” to close the Thresholds and Sample Positions dialog, and click “OK” to close the Analyzer Setup dialog.

13 Acquire and verify data:

- a** In the Listing window, set up the logic analyzer to trigger My Bus 1 value “0000”.
- b** Click the  Run icon.

The listing should look similar to:

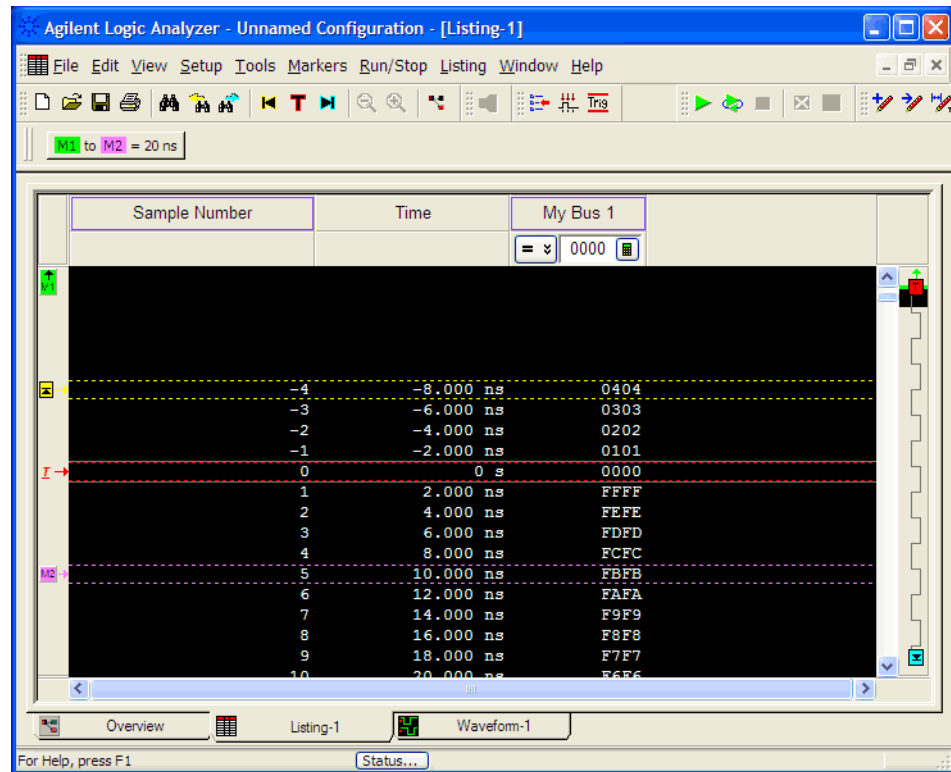

- c Scroll down at least 256 states to verify the data.

The My Bus 1 data shows two decrementing binary counters.

If the listing does not look similar the figure, there is a possible problem with the cable or high density adapter. Causes for cable test failure include:

- Open channel.
- Channel shorted to a neighboring channel.
- Channel shorted to either ground or a supply voltage.

14 If the test data is not correct, isolate the failure:

- a Reconnect probe adapter to the logic analyzer. Connect logic analyzer Pod 1 to the probe adapter output marked “Even.” Connect logic analyzer Pod 2 to the probe adapter output marked “Odd.”
- b Click the  Run icon.

The My Bus 1 data shows two incrementing binary counters.

- c Scroll down at least 256 states to verify the data.

If errors in the test data remain, suspect the logic analyzer cable.

If the errors are gone, suspect the E5378A probe adapter. If the problem is really in the probe adapter, you should have also seen it when testing the Pod 1 cable.

Return to the troubleshooting flowchart.

On a 16700-Series Mainframe

This test allows you to functionally verify the logic analyzer cable and an Agilent E5378A probe.

Equipment Required

Equipment	Critical Specification	Recommended Part
Stimulus Board	No Substitute	16760-60001

- 1 Connect the logic analyzer to the stimulus board.
 - a Connect an Agilent E5378A 100-pin single-ended probe to the logic analyzer module. Connect logic analyzer Pod 1 to the probe output marked “Odd.” Connect logic analyzer Pod 2 to the probe output marked “Even.”
 - b Connect the probe input to stimulus board connector Pod 3 (J3, 800 Mb/s, full speed clock).
 - c Connect a power cord to the stimulus board power supply. Connect the stimulus board power supply output to the stimulus board power supply connector J82.

- d** Plug in the stimulus power supply into line power. The green LED DS1 should illuminate showing that the stimulus board is active

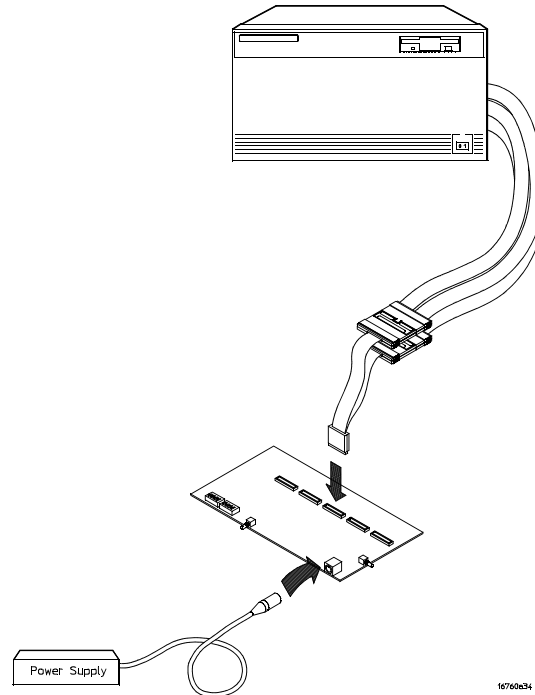

2 Set up the stimulus board.

- a** Configure the oscillator select switch S1 according to the following settings:
- S1 Off
 - S2 Off
 - S3 Off
 - Int
- b** Configure the data mode switch S4 according to the following settings:
- Even
 - Count
- c** Press the Resynch VCO button, then Counter RST (Counter Reset) button.

3 Set up the logic analyzer

- a** Open the Session Manager window and select “Start Session.”
- b** In the logic analyzer system window, select the module icon, then select Setup and Trigger. A Setup and Trigger window appears.
- c** In the logic analysis system window, select the module icon, then select Listing. A Listing window appears.

4 Set up the Sampling tab:

- a** In the logic analyzer Setup and Trigger window, select the Sampling tab.
- b** Under the Sampling tab, select State Mode.
- c** Select the clock edge field for J-clock, then select Rising Edge.

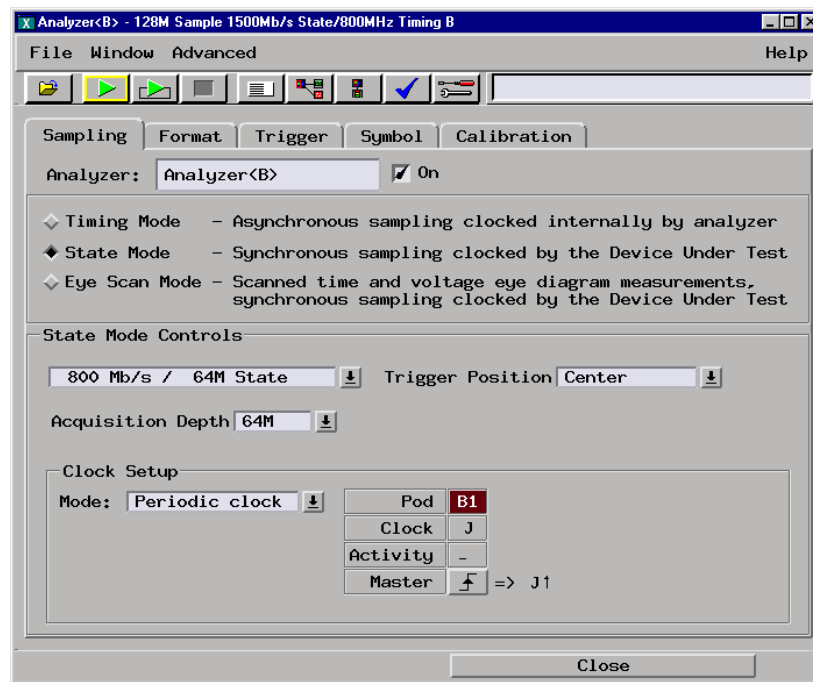
**5** Configure the Trigger settings

- a** In the logic analyzer Setup and Trigger window, select the Trigger tab.
- b** Under the Trigger tab, select the Settings tab.
- c** Select the Acquisition Depth field, then select 8K.
- d** Select the Trigger Position field, then select Start.

- e Select the Count field, then select Off.

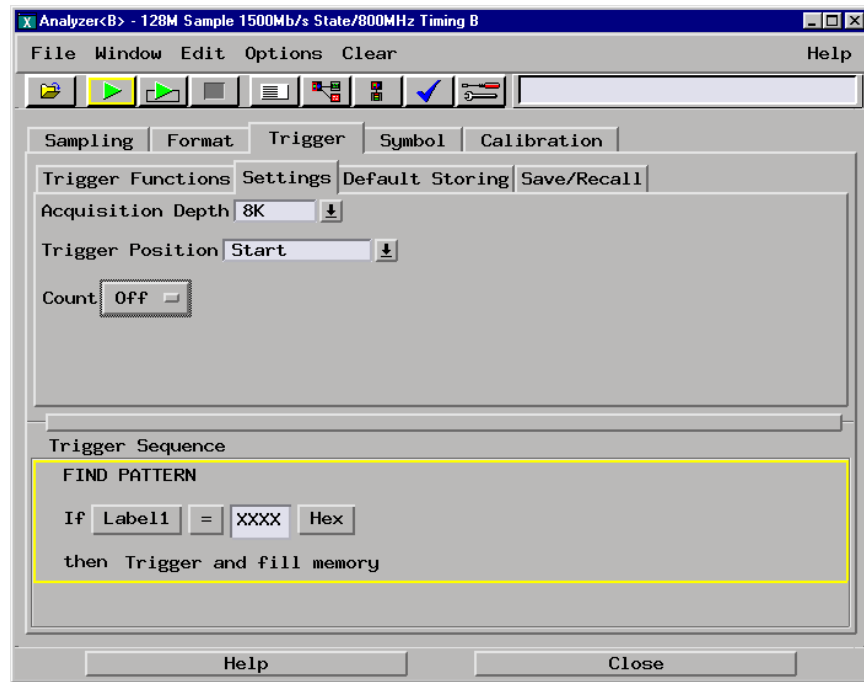

6 Configure the Format tab

- a In the logic analyzer Setup and Trigger window, select the Format tab.
- b Under the Format tab, select Pod Assignment.
- c In the Pod Assignment window, use the mouse to drag the pods to the Analyzer 1 column.

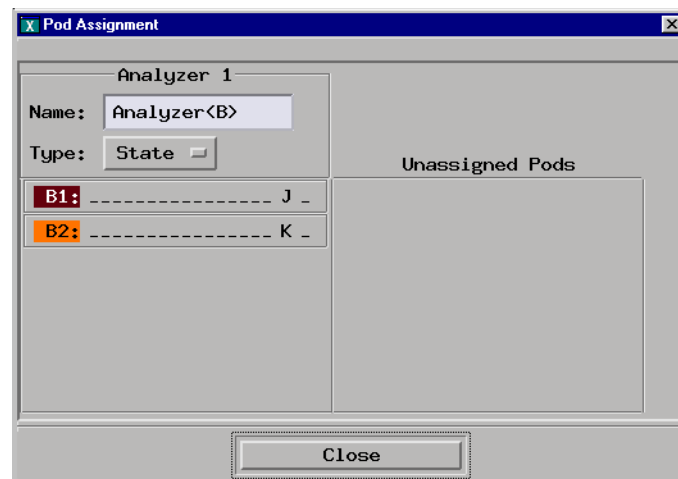

- d Select Close to close the pod assignment window.

- e Under the Format tab, select the field showing the channel assignments for one of the pods being tested, then select “*****” to active all channels.

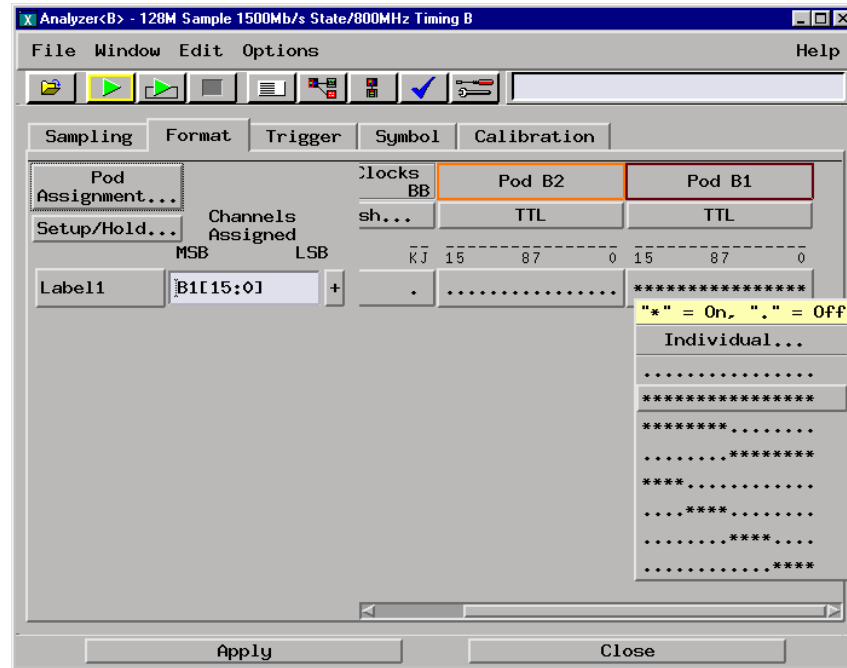

- f Select OK to close the channel assignment window.
- g Repeat e and f for the remaining pods to be tested.
- 7 Configure the logic analyzer thresholds
- a In the logic analyzer Setup and Trigger window, select the Format tab.
- b Under the Format tab, select the threshold field under either pod. The Pod threshold window will appear.
- c In the Pod threshold window, ensure the Apply threshold setting to all pods is checked.

- d** In the Pod threshold window, select User Defined, then select the threshold voltage field. Enter 1.00V.

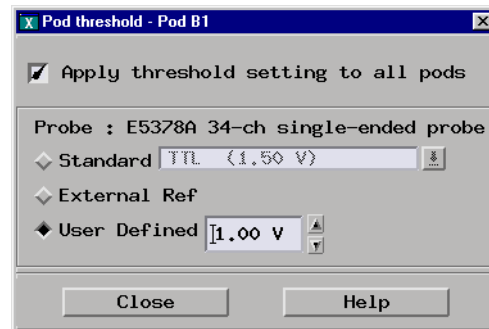

- e** Select Close to close the pod threshold window.
- f** Under the Format tab, select the Clk Thresh... field. The clock threshold window will appear.
- g** Select the threshold field associated with J-clock. The J threshold window will appear.
- h** In the J threshold window, select Differential.

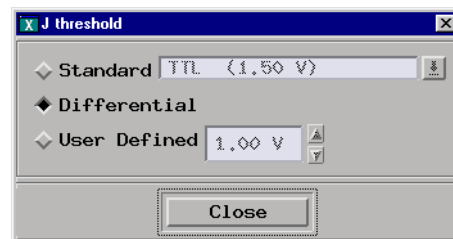

- i** Select Close to close the J threshold window, then select Close to close the Clock threshold window.

- 8 On the logic analyzer, select Run. The listing should look similar to the figure below.

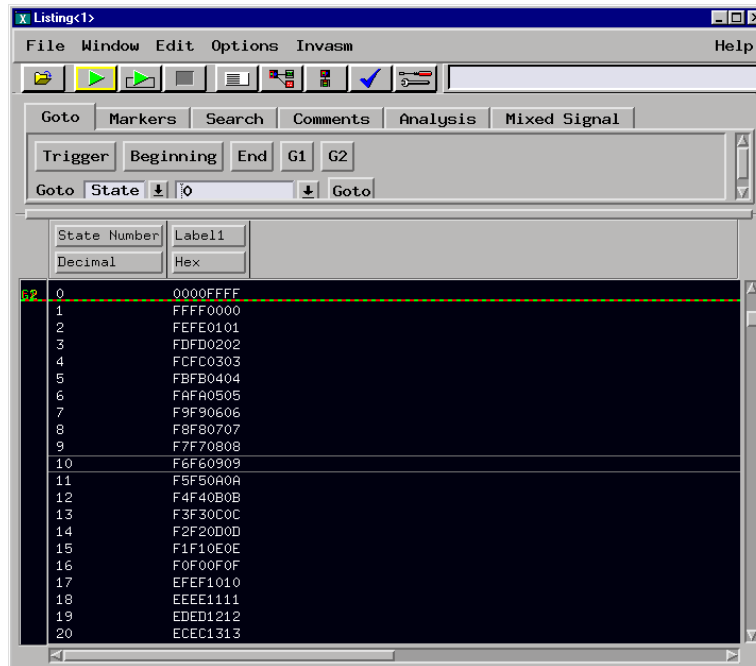

Scroll down at least 256 states to verify the data. The lower two bytes (four digits) of Label1 show two incrementing binary counters. The upper two bytes of Label1 show two decrementing binary counters. If the listing does not look similar the figure, then there is a possible problem with the cable or high density adapter. Causes for cable test failure include:

- Open channel.
- Channel shorted to a neighboring channel.
- Channel shorted to either ground or a supply voltage.

If the test data on either the lower two bytes or the upper two bytes is not correct, then perform the following step to isolate the failure.

- 9 Verify the failure
- Reconnect probe adapter to the logic analyzer module. Connect logic analyzer Pod 1 to the probe adapter output marked “Even.” Connect logic analyzer Pod 2 to the probe adapter output marked “Odd.”

- b** On the logic analyzer, select Run. Note the lower two bytes now displays two decrementing counters, the upper two bytes displays two incrementing counters.

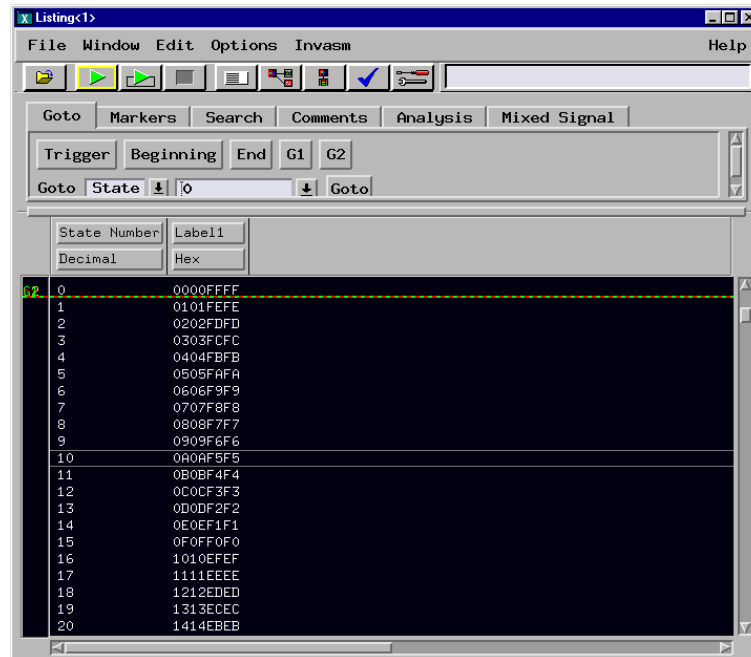

If the error in the test data remains the same two bytes as the previous run (that is, the error follows the cable) then the cable is suspect.

If the error is now in the opposite two bytes (that is, the error follows the E5378A probe adapter) the probe adapter is suspect.

Return to the troubleshooting flowchart.

To test the cables using E5379A differential probes

On a 16900-Series Mainframe

This test allows you to functionally verify the logic analyzer cables and Agilent E5379A probes.

Equipment Required

Equipment	Critical Specification	Recommended Part
Stimulus Board	No Substitute	16760-60001

- 1 Connect the logic analyzer to the stimulus board:
 - a Connect one Agilent E5379A 100-pin differential probe to the logic analyzer Pod 1 cable to be tested. Then, connect the probe input to the stimulus board connector Pod 3 (J3, 800 Mb/s, full speed clock).
 - b Connect another Agilent E5379A 100-pin differential probe to the logic analyzer Pod 2 cable to be tested. Then, connect the probe input to the stimulus board connector Pod 4 (J4, 800 Mb/s, half speed clock).
 - c Connect a power cord to the stimulus board power supply. Connect the stimulus board power supply output to the stimulus board power supply connector J82.

- d** Plug in the stimulus power supply into line power. The green LED DS1 should illuminate showing that the stimulus board is active

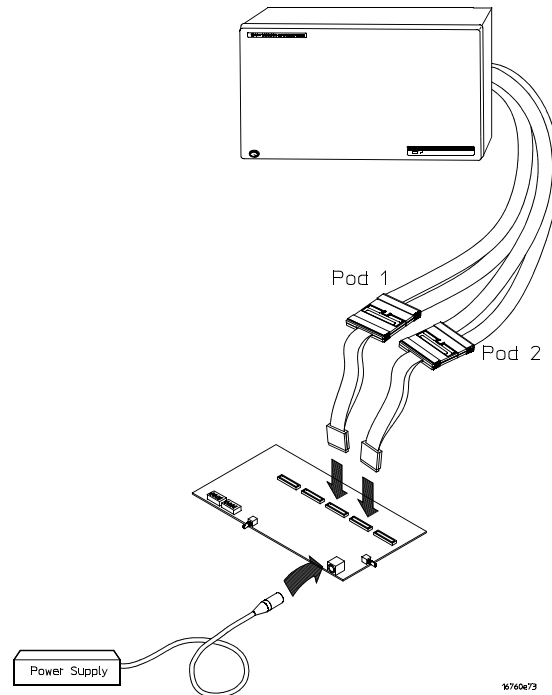

2 Set up the stimulus board:

- a** Configure the oscillator select switch S1 for an internal 500 MHz clock according to the following settings:
- S1 = 0
 - S2 = 1
 - S3 = 0
 - Int
- b** Configure the data mode switch S4 according to the following settings:
- Even
 - Count
- c** Press the Resynch VCO button; then, press the Counter RST (Counter Reset) button.
- 3** In the *Agilent Logic Analyzer* application, choose “File>New” to put the logic analysis system into its initial state.

- 4 Set up the logic analyzer's sampling mode and options:
 - a Click the  Sampling Setup icon.
 - b Select the “State - Synchronous Sampling” Acquisition mode.
 - c Set the Trigger Position to “100% poststore”.
 - d Set the Acquisition Depth to “8K”.
 - e Select the “800 Mb/s” Sampling Option.
 - f Make sure the Clock Mode is “Periodic”.
 - g Select “Rising Edge” for Pod1 Clk1.

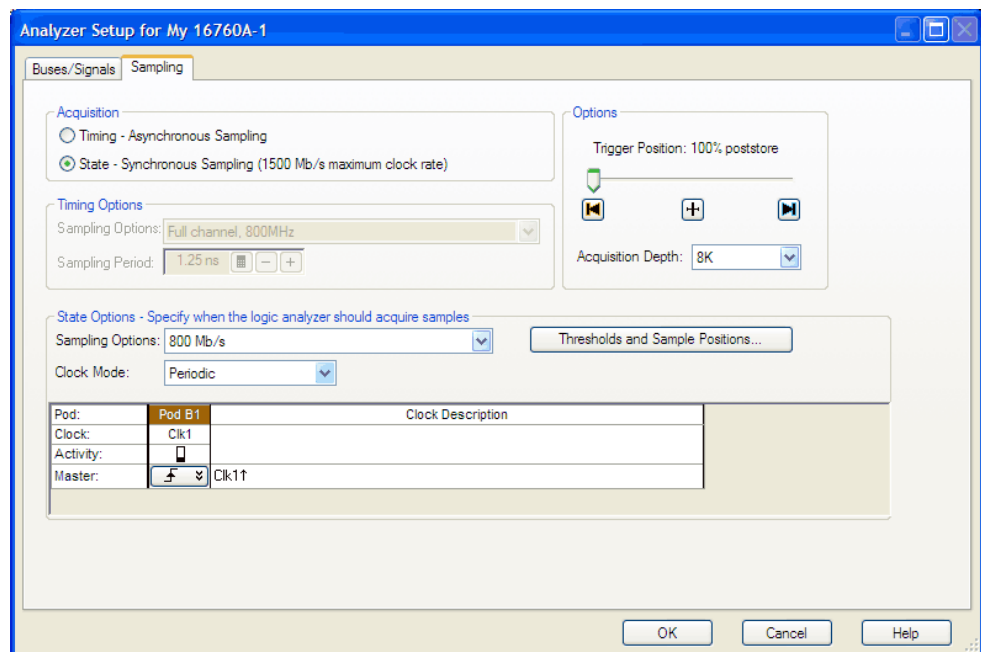

- h Click “OK” to close the Analyzer Setup dialog.
- 5 When E5479A differential probes are detected, pod and clock thresholds are set to “Differential” automatically (so you do not have to perform the step of setting up thresholds).

- 6 Set up a bus for the pod's channels:
 - a Click the  Bus/Signal Setup icon.
 - b In the Analyzer Setup dialog's Buses/Signals tab, assign all Pod 1 channels to the bus name "My Bus 1".

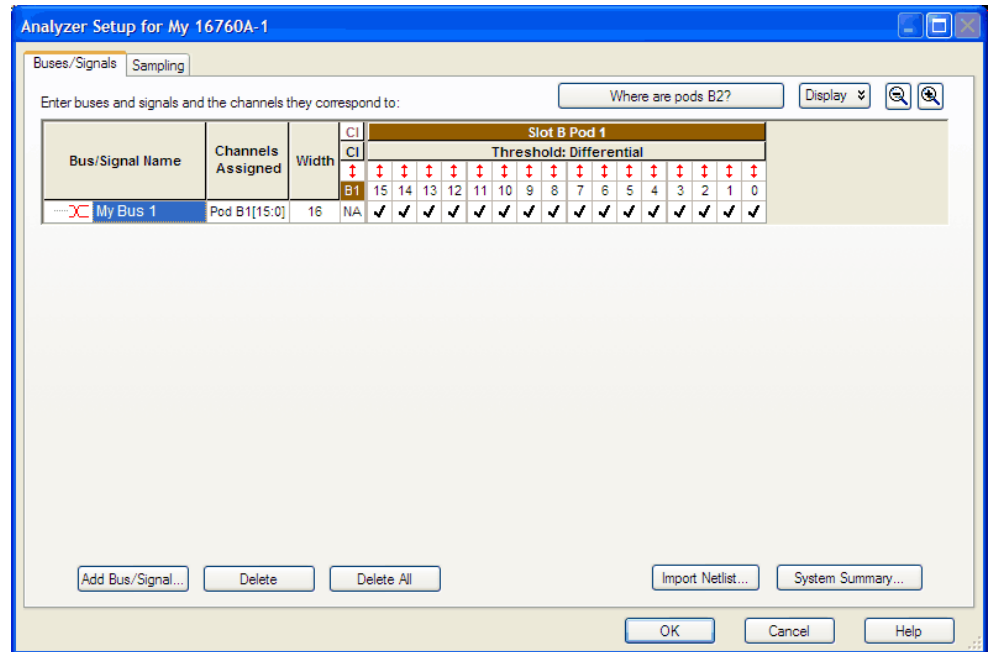

- c Click "OK" to close the Analyzer Setup dialog.
- 7 Adjust sampling positions using *eye finder*:
 - a Click the  Sampling Setup icon.
 - b In the Analyzer Setup dialog's Sampling tab, click "Thresholds and Sample Positions...".
 - c In the Thresholds and Sample Positions dialog, expand the "My Bus 1" bus name so you can see the individual signals in the bus.

- d** Click “Run” (the green button in the lower left-hand corner of the dialog). If any sample positions (blue bars) are in the wrong eye, drag the blue bars into the correct eye, and click “Run” again.

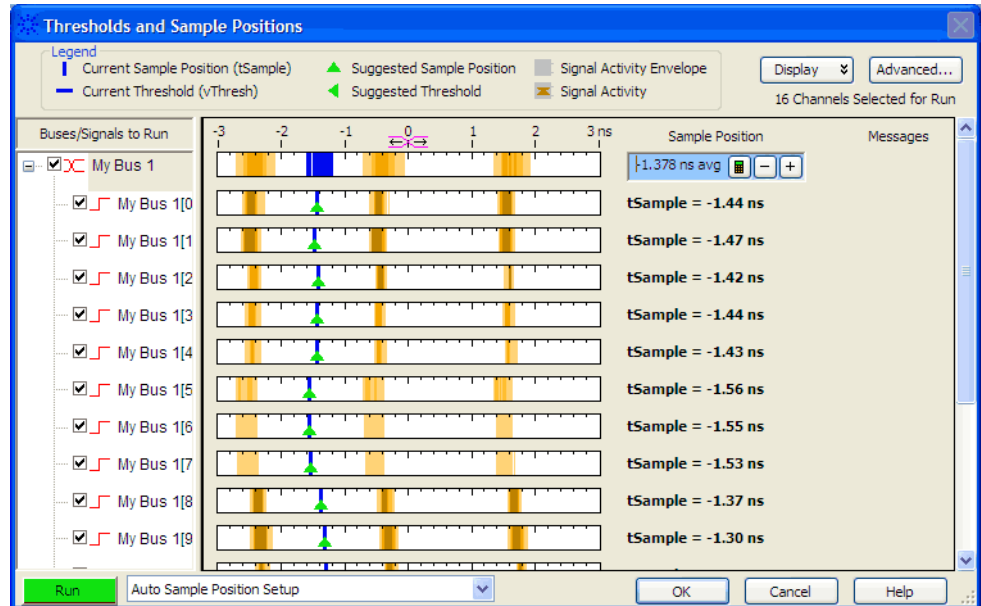

- e** Click “OK” to close the Thresholds and Sample Positions dialog, and click “OK” to close the Analyzer Setup dialog.
- 8** Acquire and verify data:
- a** In the Listing window, set up the logic analyzer to trigger My Bus 1 value “0000”.
- b** Click the  Run icon.

The listing should look similar to:

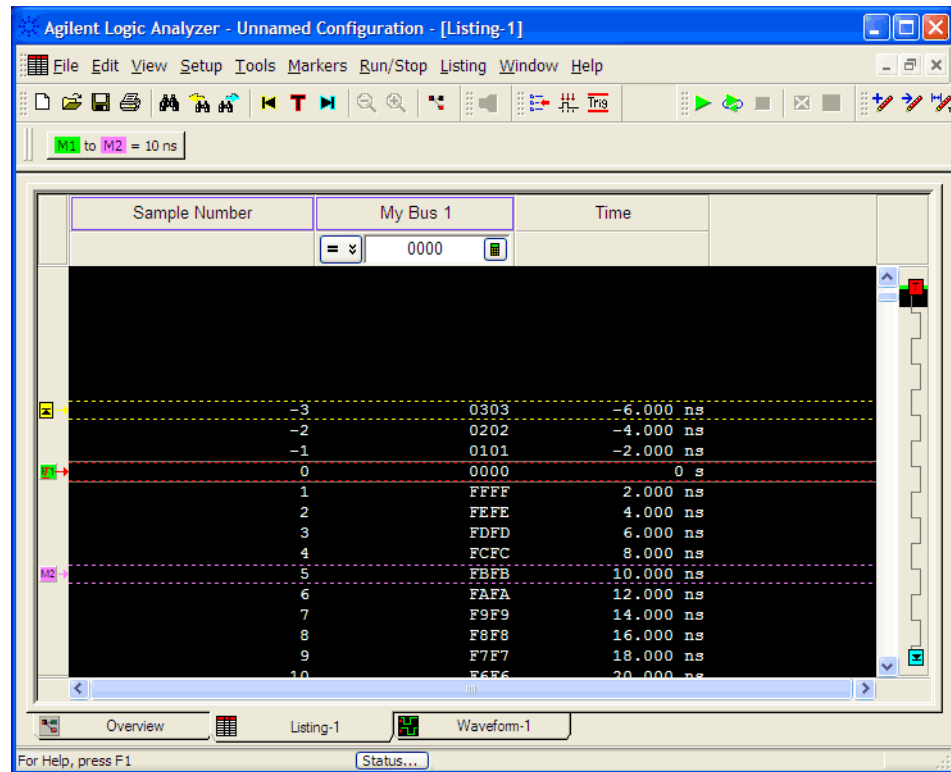

- c Scroll down at least 256 states to verify the data.

The My Bus 1 data shows two decrementing binary counters.

If the listing does not look similar the figure, there is a possible problem with the cable or high density adapter. Causes for cable test failure include:

- Open channel.
 - Channel shorted to a neighboring channel.
 - Channel shorted to either ground or a supply voltage.
- 9 If the test data is not correct, isolate the failure:
- a Swap the E5379A probe adapters. Make sure that the Pod 1 cable remains connected to stimulus board J3 and that the Pod 2 cable remains connected to stimulus board J4.
 - b Click the  Run icon.
 - c Scroll down at least 256 states to verify the data.

If errors in the test data are still there, suspect the logic analyzer cable.

If the errors are gone, suspect the E5379A probe adapter. Return the probe adapters to their original logic analyzer cable and stimulus board connections. Then, continue with the remaining steps to test the Pod 2 cable.

- 10 Change the logic analyzer pod assignment to use Pod 2:
 - a Choose “Setup>(logic analyzer module name)>Pod Assignment...”.

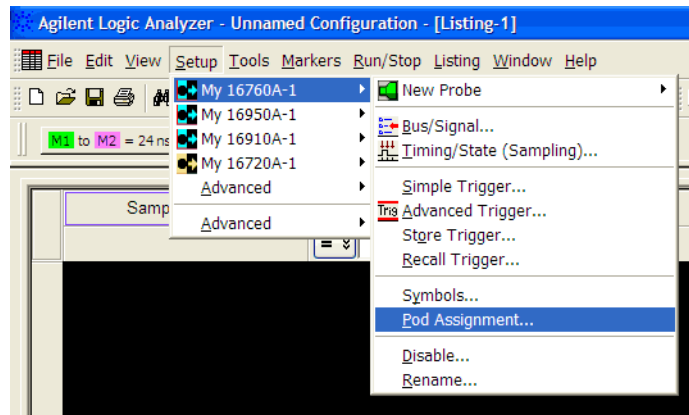

- b In the Pod Assignment dialog, select “Reserved for time tag storage” for Pod 1 and the logic analyzer module name for Pod 2.

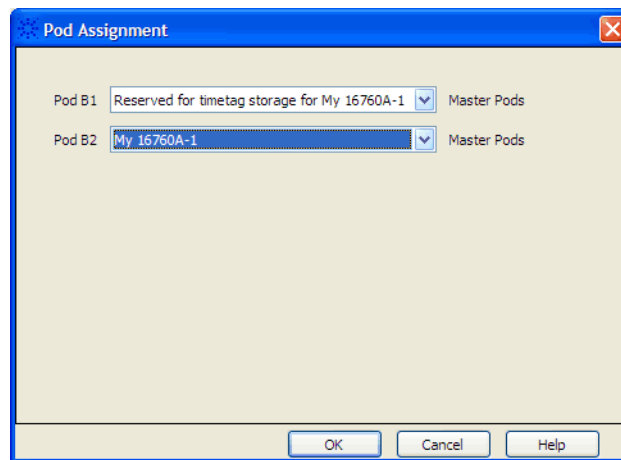

- c Click “OK” to close the Pod Assignment dialog.

11 Set up a bus for the pod's channels:

- a** Click the  Bus/Signal Setup icon.
- b** In the Analyzer Setup dialog's Buses/Signals tab, assign all Pod 2 channels to the bus name "My Bus 1".

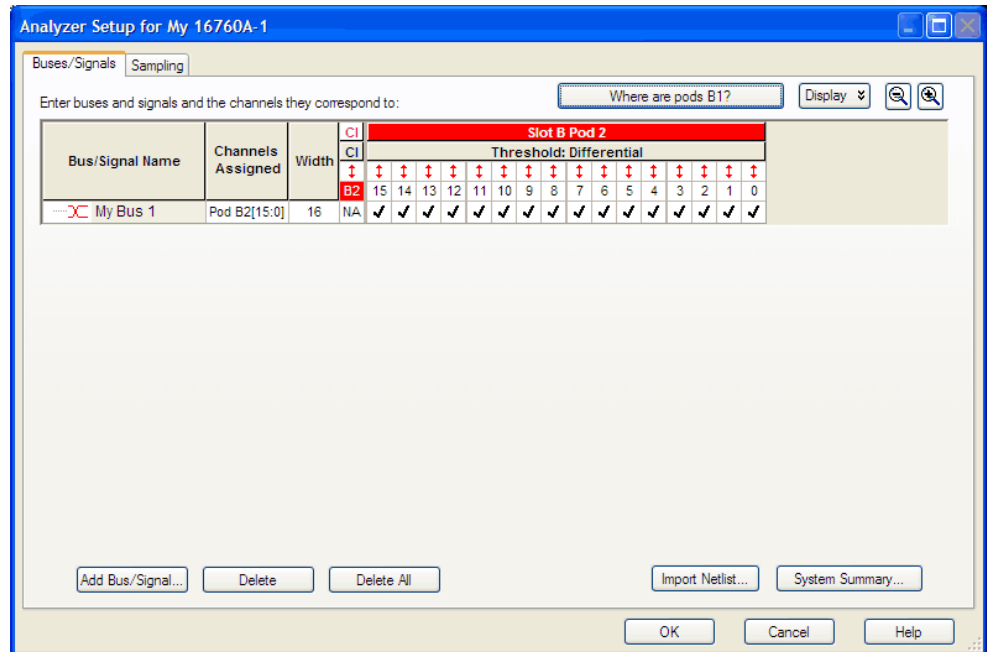

- c** Click "OK" to close the Analyzer Setup dialog.

12 Adjust sampling positions using *eye finder*:

- a** Click the  Sampling Setup icon.
- b** In the Analyzer Setup dialog's Sampling tab, click "Thresholds and Sample Positions...".
- c** In the Thresholds and Sample Positions dialog, expand the "My Bus 1" bus name so you can see the individual signals in the bus.

- d** Click “Run” (the green button in the lower left-hand corner of the dialog). If any sample positions (blue bars) are in the wrong eye, drag the blue bars into the correct eye, and click “Run” again.

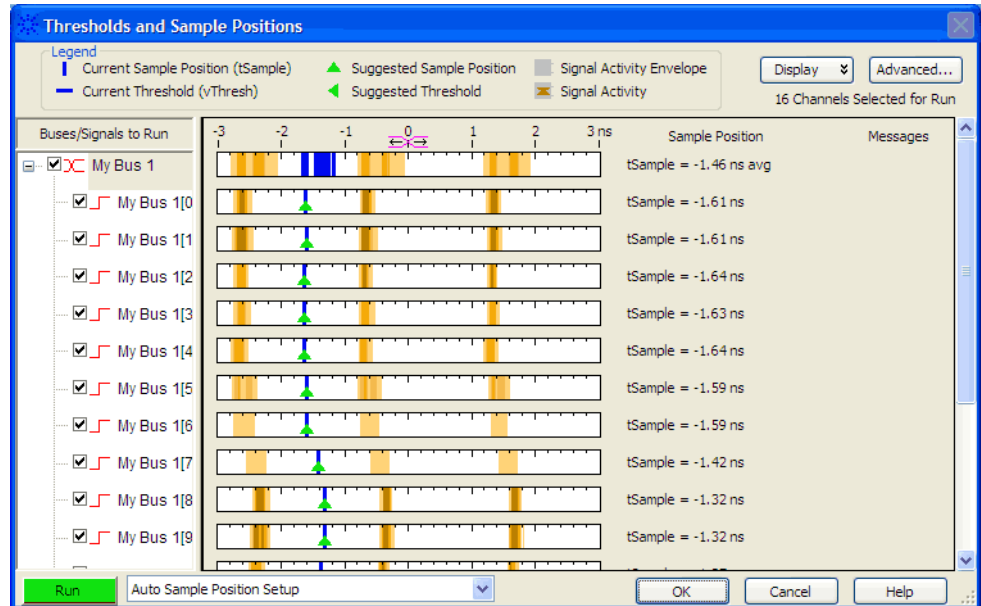

- e** Click “OK” to close the Thresholds and Sample Positions dialog, and click “OK” to close the Analyzer Setup dialog.

13 Acquire and verify data:

- a** In the Listing window, set up the logic analyzer to trigger My Bus 1 value “0000”.
- b** Click the  Run icon.

The listing should look similar to:

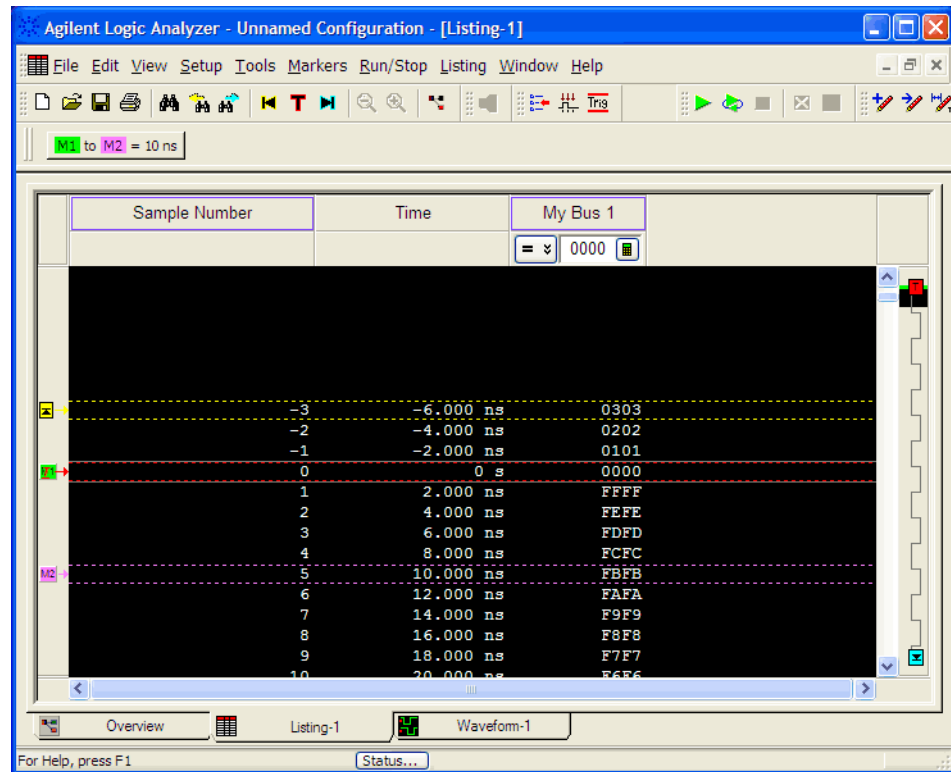

- c Scroll down at least 256 states to verify the data.

The My Bus 1 data shows two decrementing binary counters.

If the listing does not look similar the figure, there is a possible problem with the cable or high density adapter. Causes for cable test failure include:

- Open channel.
- Channel shorted to a neighboring channel.
- Channel shorted to either ground or a supply voltage.

- 14 If the test data is not correct, isolate the failure:

- a Swap the E5379A probe adapters. Make sure that the Pod 1 cable remains connected to stimulus board J3 and that the Pod 2 cable remains connected to stimulus board J4.
- b Click the  Run icon.
- c Scroll down at least 256 states to verify the data.

If errors in the test data remain, suspect the logic analyzer cable.

If the errors are gone, suspect the E5379A probe adapter. If the problem is really in the probe adapter, you should also be able to see it when testing the Pod 1 cable.

Return to the troubleshooting flowchart.

On a 16700-Series Mainframe

This test allows you to functionally verify the logic analyzer cable and an Agilent E5379A probe.

Equipment Required

Equipment	Critical Specification	Recommended Part
Stimulus Board	No Substitute	16760-60001

- 1 Connect the logic analyzer to the stimulus board.
 - a Connect an Agilent E5379A 100-pin differential probe to the logic analyzer cable to be tested.
 - b Connect the probe input to the stimulus board connector Pod 3 (J3, 800 Mb/s, full speed clock).
 - c Connect a power cord to the stimulus board power supply. Connect the stimulus board power supply output to the stimulus board power supply connector J82.

- d** Plug in the stimulus power supply into line power. The green LED DS1 should illuminate showing that the stimulus board is active.

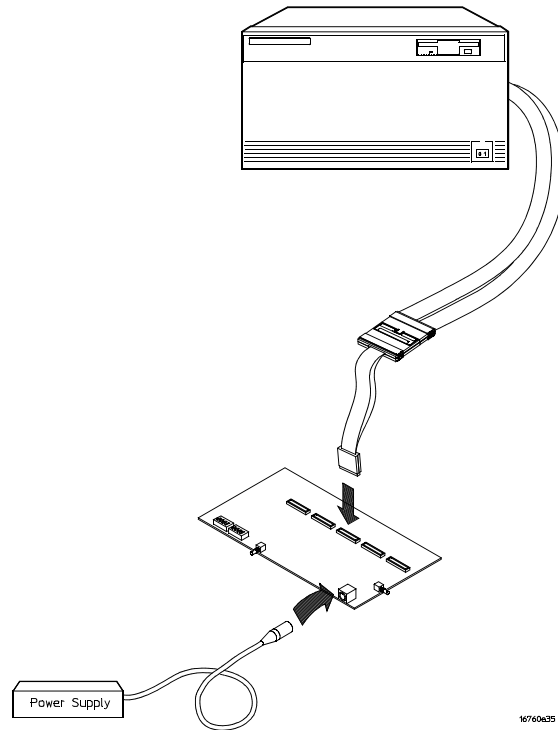

2 Set up the stimulus board

- a** Configure the oscillator select switch S1 according to the following settings:
- S1 Off
 - S2 Off
 - S3 Off
 - Int
- b** Configure the data mode switch S4 according to the following settings:
- Even
 - Count
- c** Press the Resynch VCO button, then the Counter RST (Counter Reset) button.

3 Set up the logic analyzer

- a** Open the Session Manager window and select “Start Session.”
- b** In the Logic Analysis System window, select the module icon, then select Setup and Trigger. A Setup and Trigger window appears.
- c** In the Logic Analysis System window, select the module icon, then select Listing. A Listing window appears.

4 Set up the Sampling tab

- a** In the logic analyzer Setup and Trigger window, select the Sampling tab.
- b** Under the Sampling tab, select State Mode.
- c** Select the clock edge field for J-clock, then select Rising Edge.

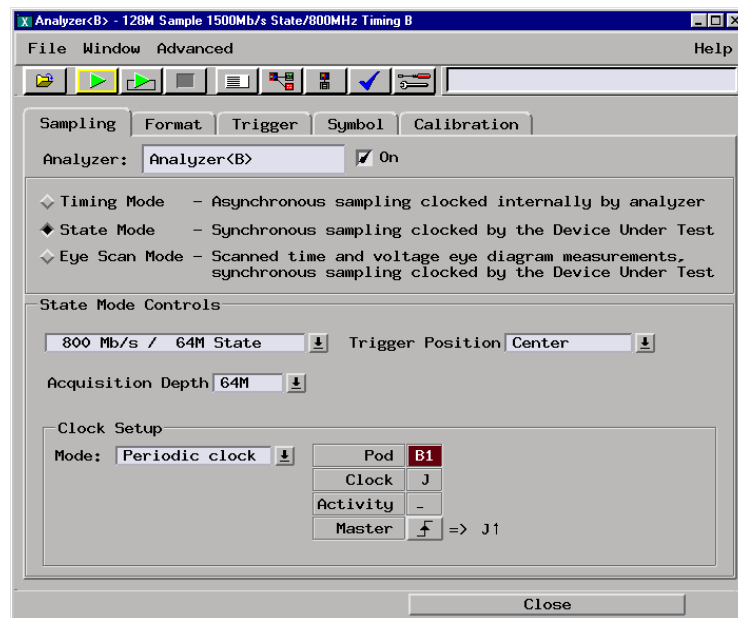
**5** Configure the Trigger settings

- a** In the logic analyzer Setup and Trigger window, select the Trigger tab.
- b** Under the Trigger tab, select the Settings tab.
- c** Select the Acquisition Depth field, then select 8K.
- d** Select the Trigger Position field, then select Start.

- e Select the Count field, then select Off.

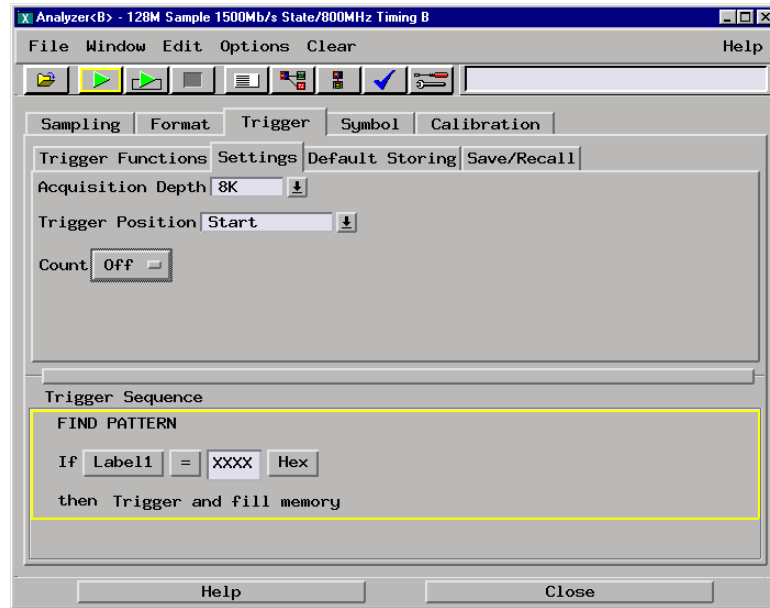

6 Configure the Format tab

- a In the logic analyzer Setup and Trigger window, select the Format tab.
- b Under the Format tab, select Pod Assignment.
- c In the Pod Assignment window, use the mouse to drag the pod under test to the Analyzer 1 column.

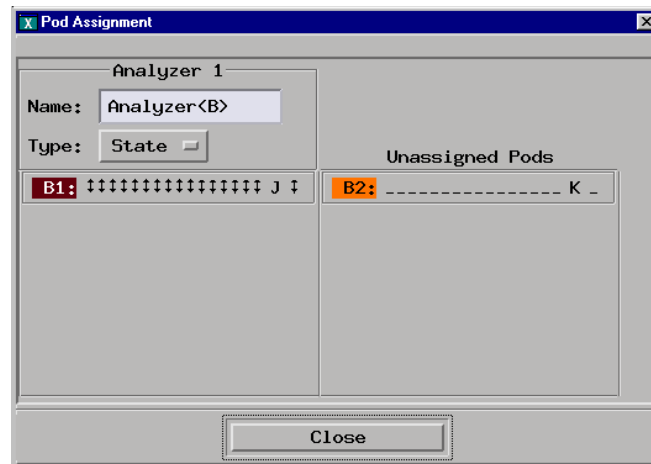

- d Select Close to close the pod assignment window.

- e Under the Format tab, select the field showing the channel assignment for the pod under test, then select “*****” to activate all channels.

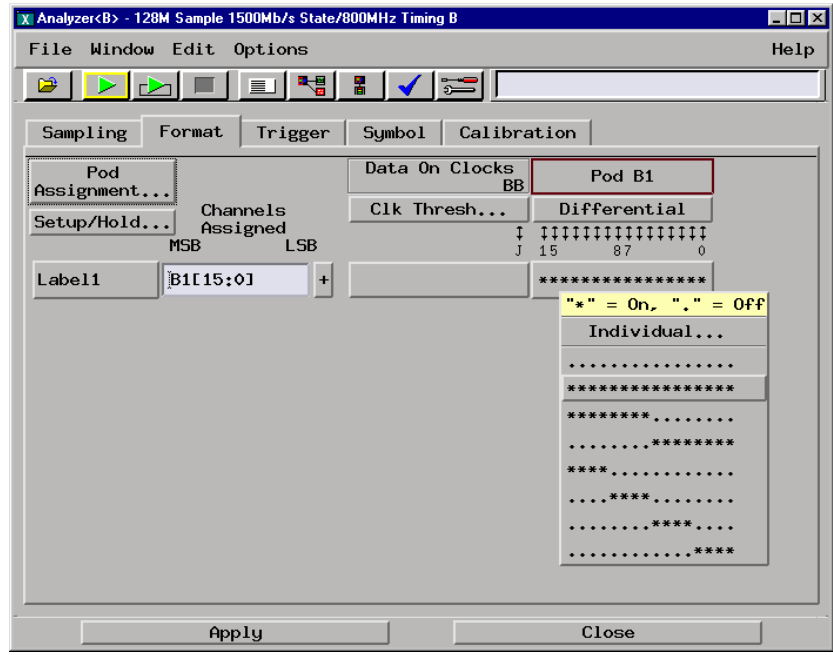

- f Select OK to close the channel assignment window.

7 Configure the logic analyzer thresholds

- a Under the Format tab, select the CLK Thresh... field. The Clock threshold window will appear.
- b Select the threshold field associated with J-clock. The J threshold window will appear.
- c In the J threshold window, select Differential.

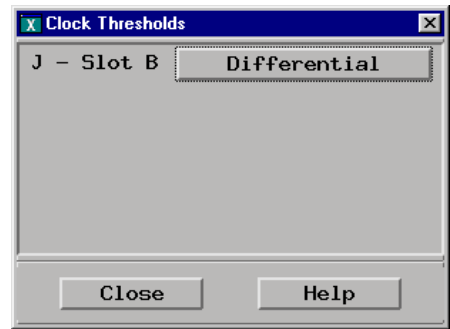

- d Select Close to close the J threshold window, then select Close to close the Clock threshold window.

- 8 On the logic analyzer, select Run. The listing should look similar to the figure below.

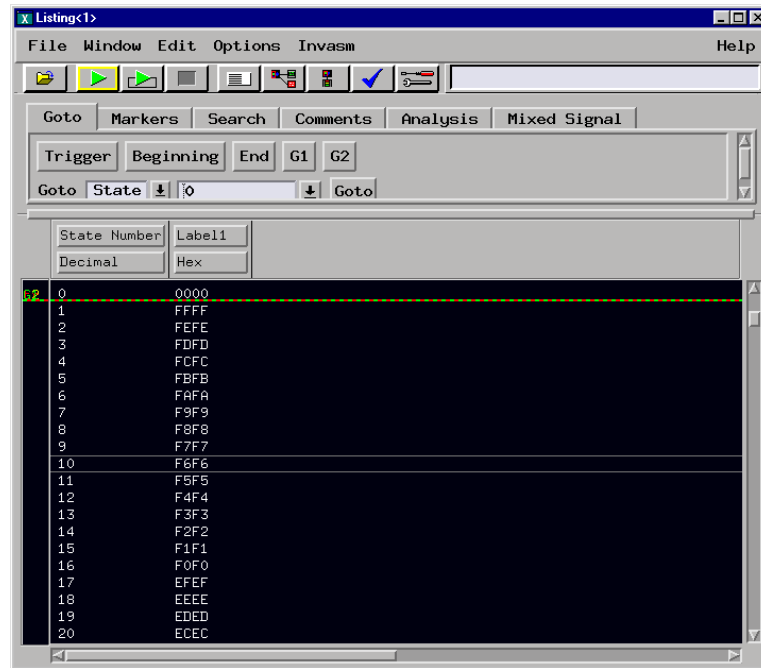

Scroll down at least 256 states to verify the data. Label1 shows two decrementing binary counters. If the listing does not look similar to the figure, then there is a possible problem with the cable or high density probe adapter. Cause for cable test failures include:

- open channel
- channel shorted to a neighboring channel
- channel shorted to either ground or a supply voltage

If the test data is not correct, then perform the following step to isolate the failure.

9 Verify the failure

- Reconnect probe adapter to the other logic analyzer cable.
- Repeat step 6 through 8 to reconfigure the Format tab in the Setup and Trigger window. Deactivate the pod just tested. Activate the pod to be tested and assign all channels to Label1.
- On the logic analyzer, select Run. The expected test data is the same as in step 8 above.

If the test data is now correct (that is, the error follows the cable) then the cable is suspect.

If the test data is still not correct (that is, the error follows the E5379A probe adapter) the probe adapter is suspect.

Return to the troubleshooting flowchart.

Replacing Assemblies

This chapter contains the instructions for removing and replacing the logic analyzer module, the circuit board of the module, and the probe cables of the module as well as the instructions for returning assemblies.

CAUTION: Turn off the instrument before installing, removing, or replacing a module in the instrument.

CAUTION: Electrostatic discharge can damage electronic components. Use grounded wrist-straps, mats, and standard ESD precautions when you perform any service to the mainframe or the modules in it.

Tools Required

- A T10 TORX screwdriver, to remove screws connecting the probe cables and screws connecting the back panel.

To remove the module

Instructions for removing or installing the module into the mainframe can be found in the installation guide for the mainframe.

If you don't have the installation guide for your mainframe, you can find the latest version on the Internet at www.agilent.com.

For example: to find the installation guide for a 16700B mainframe, go to www.agilent.com and enter "16700B installation guide" in the quick search box. Then, scroll down to "Manuals, Guides & Notifications" to find the *16700B-Series Logic Analysis Systems Installation Guide*.

To remove the logic analyzer cable

- 1** Remove power from the instrument
 - a** Exit all logic analysis session. In the session manager, select Shutdown.
 - b** At the query, select Power Down.
 - c** When the “OK to power down” message appears, turn the instrument off.
 - d** Disconnect the power cord.
- 2** Remove the logic analyzer cable clamp.
 - a** Remove two screws that secure the top logic analyzer cable clamp to the outside rear panel.
 - b** Remove two screws that secure the top cable clamp to the inside rear panel.
 - c** Slide the top cable clamp out of the rear panel.

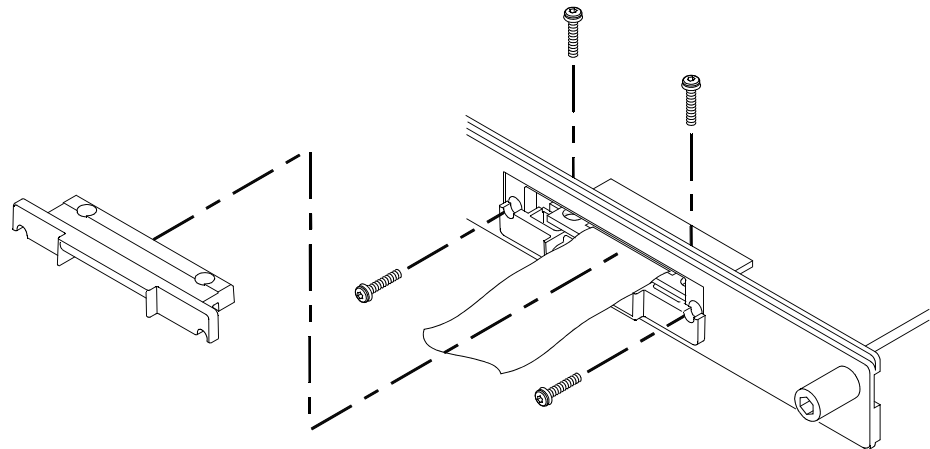

16760e18

- 3** Remove the logic analyzer cable.
 - a** Gently lift the logic analyzer cable end connector from the circuit board connector (J1 or J2).
 - b** Remove the logic analyzer cable end connector through the rear panel. The bottom cable clamp will also be removed with the logic analyzer cable.
- 4** If the logic analyzer cable is faulty, replace the cable and follow the next procedure to install the replacement logic analyzer cable.

To install the logic analyzer cable

- 1** Connect the logic analyzer cable to the logic analyzer circuit board.
 - a** Insert the logic analyzer cable to the logic analyzer circuit board.
 - b** Align the logic analyzer cable end connector with the circuit board cable connector (J1 or J2) and gently apply pressure to seat the logic analyzer cable onto the circuit board connector.
 - c** Insert the top and bottom logic analyzer cable clamps into the rear panel.

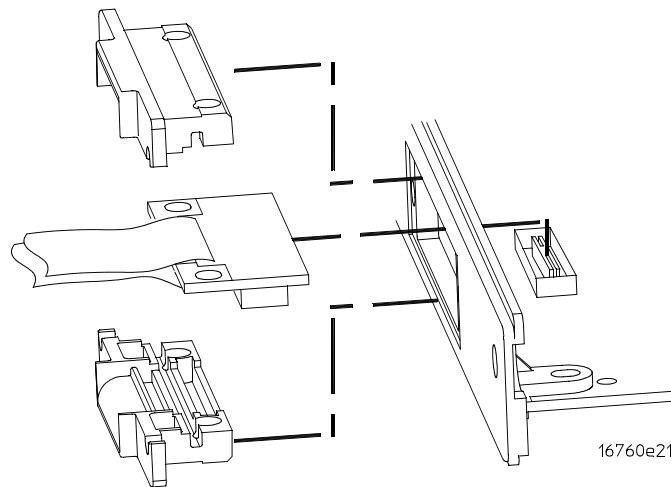

- 2** Secure the cable clamp to the rear panel.
 - a** Install the two longer screws (H5) vertically through the top cable clamp into both the bottom cable clamp and the circuit board. Do not tighten the screws yet.

- b** Install the two shorter screws (H4) through the rear of both cable clamps into the rear panel. Do not tighten the screws yet.

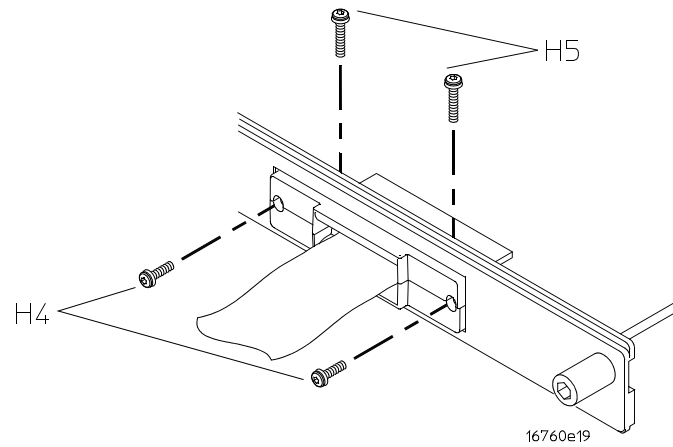

- c** Tighten the short rear panel cable clamp screws (H4) to 5 in/lb. Then tighten the longer cable clamp screws (H5) to 5 in/lb.

CAUTION:

If you over tighten the screws, the threaded inserts on the rear panel, the threaded inserts on the circuit board, or the cable clamp itself might break. Tighten the screws only enough to hold the cable in place, approximately 5 in/lb.

To replace the circuit board

- 1** Remove both logic analyzer cables using the “To remove the logic analyzer cable” procedure on page 173.
- 2** Remove the four screws attaching the ground spring and back panel to the circuit board, then remove the back panel and the ground spring.
- 3** Replace the faulty circuit board with a new circuit board. On the faulty board, make sure the 20-pin ribbon cable is connected between J3 and J6.
- 4** Position the ground spring and back panel on the back edge of the replacement circuit board. Install four screws to connect the back panel and ground spring to the circuit board.
- 5** Install both logic analyzer cables using the procedure “To install the logic analyzer cable” on page 174.

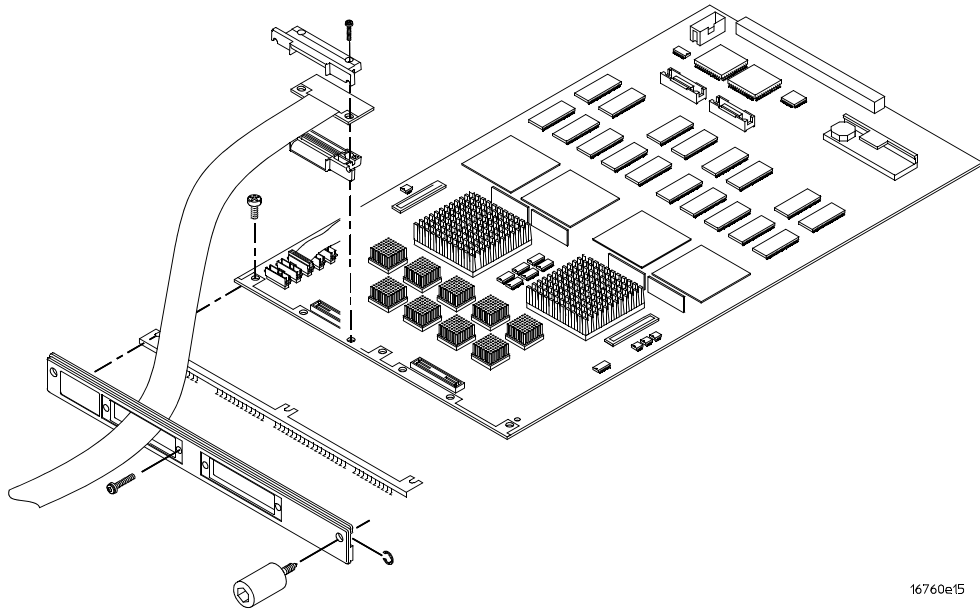

To return assemblies

Before shipping the module to Agilent Technologies, contact your nearest Agilent Technologies Sales Office for additional details. Information on contacting Agilent can be found at <http://www.agilent.com>.

1 Write the following information on a tag and attach it to the module.

- Name and address of owner.
- Model number.
- Serial number.
- Description of service required or failure indications.

2 Remove accessories from the module.

Only return accessories to Agilent Technologies if they are associated with the failure symptoms.

3 Package the module.

You can use either the original shipping containers, or order materials from an Agilent Technologies sales office.

CAUTION:

For protection against electrostatic discharge, package the module in electrostatic material.

4 Seal the shipping container securely, and mark it FRAGILE.

Replaceable Parts

This chapter contains information for identifying and ordering replaceable parts for your module.

Replaceable Parts Ordering

Parts listed

To order a part on the list of replaceable parts, quote the Agilent Technologies part number, indicate the quantity desired, and address the order to the nearest Agilent Technologies Sales Office.

Parts not listed

To order a part not on the list of replaceable parts, include the model number and serial number of the module, a description of the part (including its function), and the number of parts required. Address the order to your nearest Agilent Technologies Sales Office.

Direct mail order system

To order using the direct mail order system, contact your nearest Agilent Technologies Sales Office.

Within the USA, Agilent Technologies can supply parts through a direct mail order system. The advantages to the system are direct ordering and shipment from the Agilent Technologies Part Center in Mountain View, California. There is no maximum or minimum on any mail order. (There is a minimum amount for parts ordered through a local Agilent Technologies Sales Office when the orders require billing and invoicing.) Transportation costs are prepaid (there is a small handling charge for each order) and no invoices.

In order for Agilent Technologies to provide these advantages, a check or money order must accompany each order. Mail order forms and specific ordering information are available through your local Agilent Technologies Sales Office. Addresses and telephone numbers are located in a separate document shipped with the *Agilent Technologies 16900-Series (or 16700-Series) Logic Analysis System Service Manual*.

Exchange assemblies

Some assemblies are part of an exchange program with Agilent Technologies.

The exchange program allows you to exchange a faulty assembly with one that has been repaired and performance verified by Agilent Technologies.

After you receive the exchange assembly, return the defective assembly to Agilent Technologies. A United States customer has 30 days to return the defective assembly. If you do not return the defective assembly within the 30 days, Agilent Technologies will charge you an additional amount. This amount is the difference in price between a new assembly and that of the exchange assembly. For orders not originating in the United States, contact your nearest

Agilent Technologies Sales Office for information.

See Also

“To return assemblies” on page 177.

Replaceable Parts List

The replaceable parts list is organized by reference designation and shows exchange assemblies, electrical assemblies, then other parts.

Information included for each part on the list consists of the following:

- Reference designator.
- Agilent Technologies part number.
- Total quantity included with the module (Qty).
- Description of the part.

Reference designators used in the parts list are as follows:

- A Assembly.
- H Hardware.
- J Connector.
- MP Mechanical Part.
- W Cable.

Replaceable Parts			
Ref. Des.	Agilent Part Number	QTY	Description
Exchange Assemblies			
	16760-69516		Exchange Acquisition Board Assembly
Replacement Assemblies			
A1	16760-66516	1	Acquisition Board Assembly
H1	16500-22401	2	Panel Screw
H2	16500-29101	1	Ground Spring
H3	0510-0684	2	Retaining Ring
H4	0515-0372	4	M3.0x0.5 8mm T10 (Cable Clamp to Rear Panel)
H5	0515-0375	4	M3.0x0.5 16mm T10 (Cable Clamp to Acquisition Board)
H6	0515-0430	3	MSPH M3.0x0.50 6mm T10 (Rear Panel to Acquisition Board)
MP1	01650-94312	1	Label Set - Probe and Cable
MP2	16760-44107	1	Rear Panel
MP3	16760-44108	4	Logic Analyzer Cable Clamp (two clamps per cable)
MP4	16760-94309	1	Module ID Label
W1	16555-61605	1	Cable (2x20)
W2	16715-60001	1	Master/Expander Cable Kit
W3	16760-61601	2	Logic Analyzer Cable
Accessories for Connectivity to the System Under Test			
	E5379A		Differential Probe
	E5378A		Single-Ended Probe, 100-pin
	E5380A		Single-Ended Probe, 38-pin
	E5382A		Flying Lead Probe
	E5381A		Differential Flying Lead Probe Set
	E5386A		Half-channel Adapter
	E5387A		Differential Soft Touch Connectorless Probe
	E5390A		Single-ended Soft Touch Connectorless Probe
	1253-3620		Samtec Connector
	16760-02302		Shroud for 0.062" PC Boards
	16760-02303		Shroud for 0.120" PC Boards
	16760-68702		*Shroud/Connector Kit for 0.062" PC Boards
	16760-68703		*Shroud/Connector Kit for 0.120" PC Boards
	1252-7431		MICTOR Connector
	E5346-44703		MICTOR Shroud for 0.170" PC Boards
	E5346-44704		MICTOR Shroud for 0.125" PC Boards
	E5346-68700		*Shroud/Connector Kit for 0.125" PC Boards

*Shroud/Connector kits include connectors (Qty 5) and shrouds (Qty 5) for the indicated system under test circuit board thickness.

Exploded View

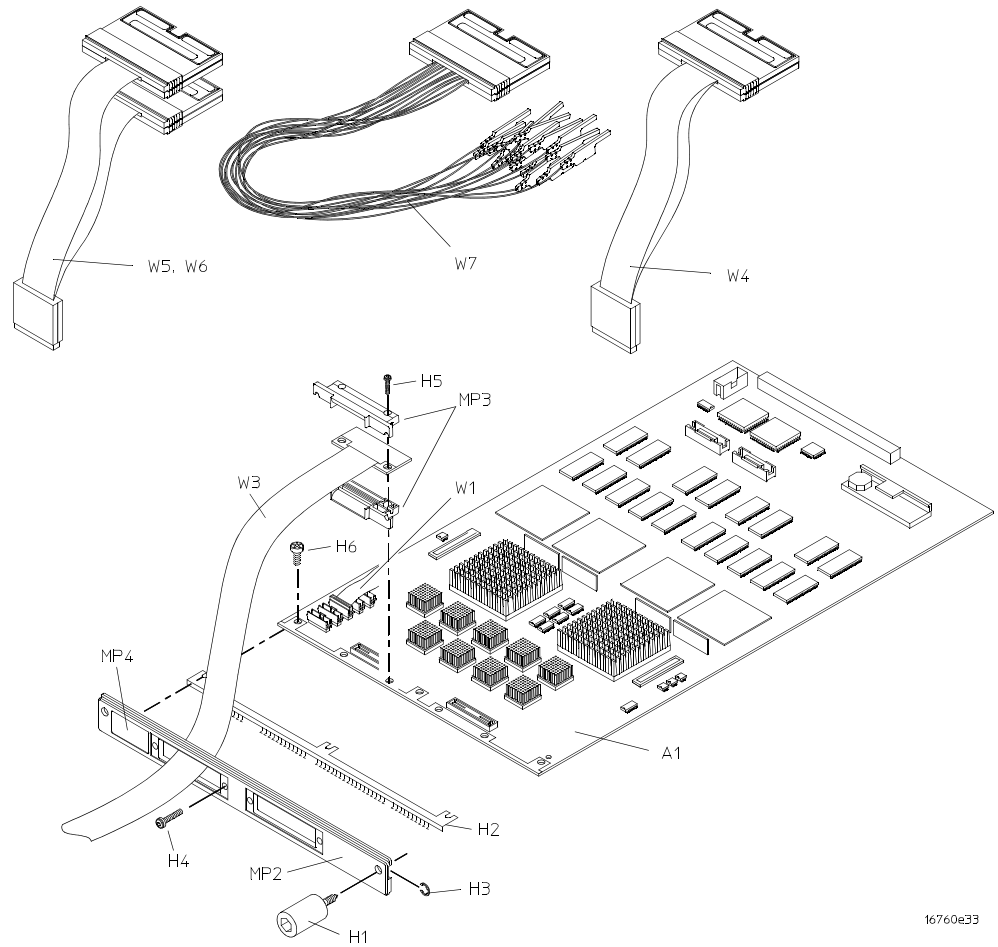

16760e33

Exploded view of the 16760A logic analyzer

E5382A Accessories

The following figure shows the accessories supplied with the E5382A Single-ended Flying Lead Probe Set.

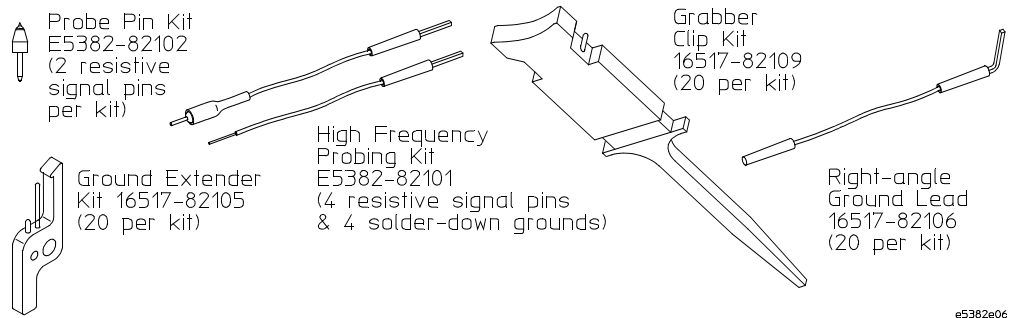

Accessories supplied

The following table shows the part numbers for ordering replacement parts and additional accessories.

Replaceable Parts and Additional Accessories

Description	Qty	Agilent Part Number
Probe Pin Kit	4	16517-82107
High Frequency Probing Kit (4 resistive signal pins & 4 solder-down grounds)	8	16517-82104
Ground Extender	20	16517-82105
Grabber Clip Kit	20	16517-92109
Right-angle Ground Lead	20	16517-82106
Cable - Main	1	E5382-61601
Probe Tip to BNC Adapter	1	E9638A

Theory of Operation

This chapter presents the theory of operation for the logic analyzer module and describes the self-tests.

The information in this chapter is to help you understand how the module operates and what the self-tests are testing. This information is not intended for component-level repair.

Block-Level Theory

The block-level theory of operation is divided into two parts: theory for the logic analyzer used as a single-card module or as a master card in a multi-card module, and theory for the logic analyzer used as an expander card in a multi-card module. A block diagram is shown before each theory.

The 16760A logic analyzer

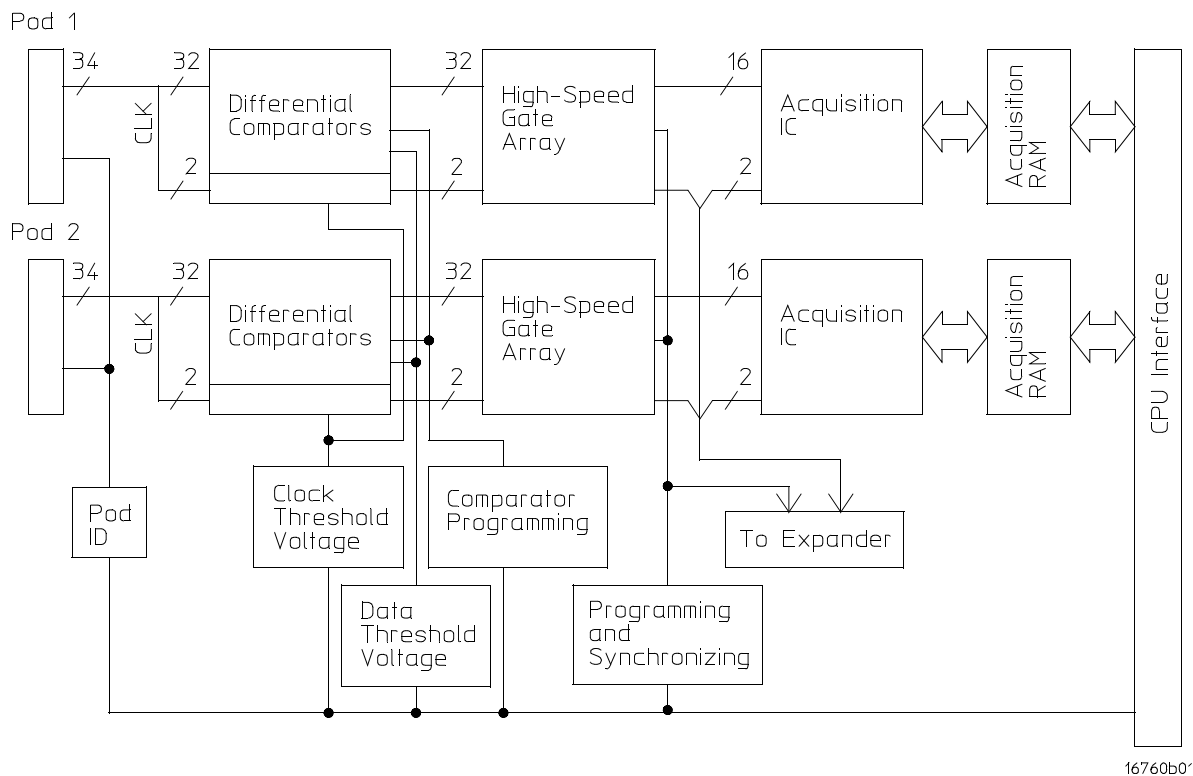

Probe Adapter and Pods. Each pod includes 17 differential channels of analysis data, a threshold voltage input, two serial I2C lines for adapter probe identification, and 50 ground signals. The 17 differential channels of are fed from the probe adapter into the logic analyzer cable (pod) input. For signal-ended operation, the negative side of each of the 17 differential signals is coupled to ground inside the single-ended probe adapter.

On the end of the Samtec probe adapter is a 100-pin application-specific Samtec

connector. The mate to this Samtec connector must be designed into and installed in the system under test. Analysis of single-ended or differential signals is performed depending on whether the single-ended or differential probe adapter is used.

A Mictor-compatible probe adapter is also available. Like the Samtec probe adapter, the Mictor probe adapter is used for single-ended signal analysis through a Mictor connector designed in and installed into a system under test. Note that the performance of the logic analyzer module is limited when a Mictor-compatible probe adapter is used.

A threshold voltage input is provided through the probe adapter and pod for the user to configure the logic analyzer threshold voltage using the threshold voltage of the system under test. The logic analyzer module will then utilize the threshold voltage input to determine the logic high and logic low state of the incoming signals. The logic analysis system user interface allows the user to select the threshold voltage input. The threshold voltage input is designed with safeguards to protect the logic analyzer module from destructive effect of electro-static discharge (ESD).

The serial I2C lines are used to communicate with the probe adapter for identification. Periodic polling allows hot insertion of the probe adapter to the 16760A pod. When the probe adapter is installed at the end of the pod, the logic analyzer module polls the ID of the probe adapter. The module then configures itself for either single-ended or differential signal analyzer. The serial I2C lines are also designed with ESD safeguards.

The pods provide a 5 Vdc $\pm 5\%$ auxiliary power to the end of the cable. A thermal protection circuit senses any over-current and automatically disables the auxiliary power. The auxiliary power circuit is designed with safeguards to protect the logic analyzer module from the effects of electro-mechanical interference (EMI). Additionally, a voltage ramp circuit allows an analysis probe to be hot inserted onto the end of the pod cable. Note that there are currently no analysis probes or other accessories utilizing this auxiliary power that are designed for the 16760A logic analyzer module as of the printing of this service manual.

Comparators. The comparators are differential input/differential output devices that interpret the incoming data and clock signals as either high or low. Threshold voltage, programmed by the user through the user interface, is set by a digital-to-analog converter (DAC) coupled to the negative side of the differential signal through a precision resistor. There are separate DAC-driven threshold voltages for the data and for the clock. In addition, the comparator contains a diode in which the junction temperature is monitored to ensure the module is being properly cooled.

Much of the performance optimization for the module is accomplished by the comparators, including channel delay setting (EyeFinder), programming of input resistance, and frequency compensation adjustment. Module operation such as

state clock modes and configuration are also done by the comparators. A digital-to-analog convertor (DAC) provides the module threshold voltage for single-ended operation. The voltage at the DAC outputs are buffered to provide sufficient line drive. An analog switch is used to channel either the module threshold voltage from the DAC or the threshold voltage input from the system under test to the comparators.

High Speed Gate Array. The high speed gate arrays sample the incoming data in the high speed state modes. The gate arrays have differential inputs and single-ended outputs and translate the incoming data from differential to single-ended signals. The output of the high speed gate arrays is channeled to the input of the acquisition ICs. A synchronizing signal ensures the gate arrays sample the data in step. A programming interface configures the operation of the gate arrays. In addition, each gate array device contains a diode in which the junction temperature is monitored to ensure the module is being cooled properly.

Acquisition IC. Each acquisition circuit is made up of a single acquisition IC. Each acquisition IC functions as a 17-channel state/timing logic analyzer. Two acquisition ICs are included on every single logic analyzer card for a total of 32 data channels and 2 clock/data channels. All of the sequencing, storage qualification, pattern/range recognition and even counting functions are performed by the acquisition IC.

The acquisition ICs perform master clocking functions. The state acquisition clock is sent to each acquisition IC, and the acquisition ICs generate their own sample clock. Every time the user selects RUN, the acquisition ICs individually perform a clock optimization before data is stored. Clock optimization involves using programmable delays in the acquisition ICs to position the master sampling clock transition where valid data is captured. This procedure reduces the effects of channel-to-channel skew and other propagation delays.

In timing acquisition mode, a 100 MHz backplane clock from the logic analysis system mainframe drives the sample rate of the acquisition ICs. A master acquisition IC monitors the RUN signal asserted based on user input. The master acquisition IC then gates the sample clocks to all other acquisition ICs in the module.

Acquisition memory. The acquisition memory is a bank of 16-bit SDRAM devices and stores the processed data from the acquisition IC. Acquisition memory input/output is controlled by a memory controller, a bank of field programmable gate arrays (FPGA). The memory controller is initialized when power is applied to the logic analysis system from files stored on the system hard disk drive. During normal operation of the module, the memory controller is reprogrammed based on configuration of the module from user input. A second initialization file is loaded into the memory controller when the performance verification software is loaded into the system.

CPU Interface. The CPU interface is a programmable logic device that converts the bus signals generated by the microprocessor on the mainframe CPU card into control signals for the logic analyzer module. All functions of the state and timing module can be controlled from the backplane of the mainframe system including storage qualification, sequencing, assigning clock edges, RUN and STOP, and thresholds. Data transfer between the logic analyzer cards and the mainframe CPU is also accomplished through the CPU interface.

Master/Expander Configuration

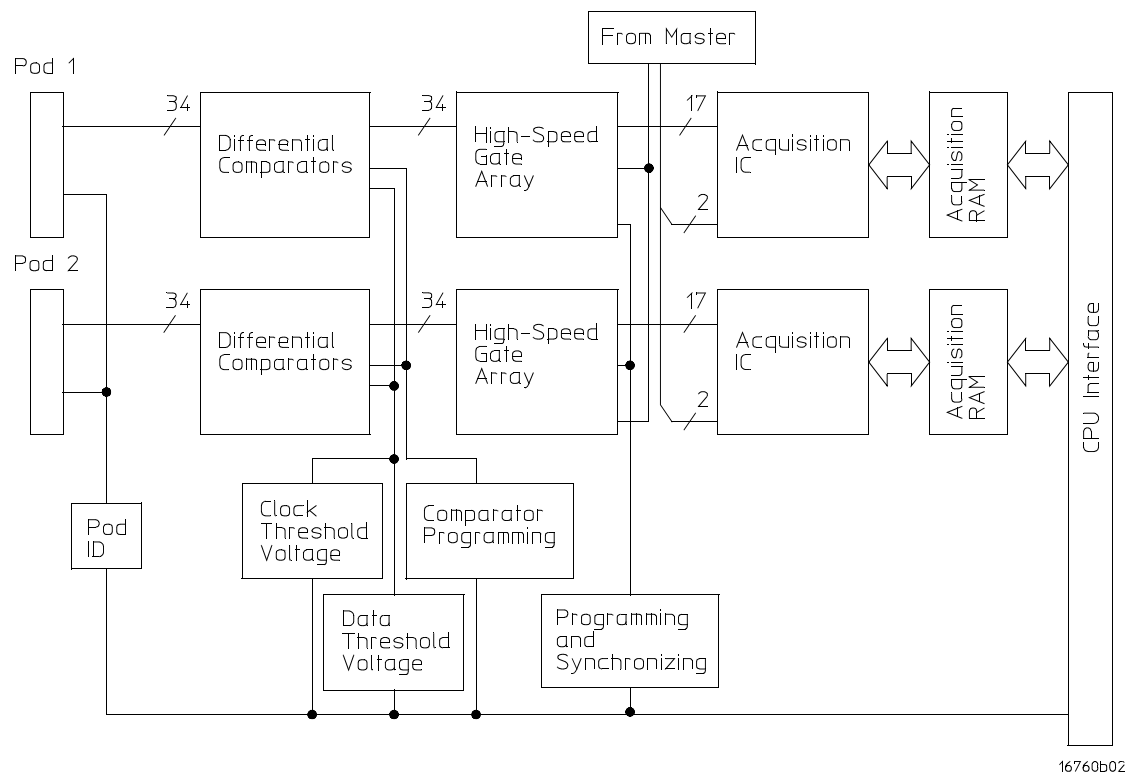

Connectors J3 and J8 route clock and signals for operational accuracy calibration to expander boards in a master/expander multcard module. The master-configured module has the common connector (J3) cabled to the master connector (J6) expander board have their common connector cabled to the expander connectors (J4, J5, J7, and J8) of the master-configured board. Clock signals generated from either the master acquisition IC (timing mode) or from the system under test (state mode) are distributed to the expander boards through the master/expander star connectors. Clock generation is disabled to all expander boards. Additionally, a pattern found signal is routed from all configured expander boards to the master board through the star connectors. When the module is in pattern search mode, the pattern found signal is asserted by the expander board with the found pattern.

Connectors J9, J10, J500, and J501 form and acquisition IC pattern resource bus.

In addition to the master board, identification and operational configuration of the expander boards are done through the CPU interface.

A

accessories, 10
acquisition, 128
 IC, 188
 memory, 188
ADC
 test, 131
assemblies
 exchange, 180
 return, 177

B

block-level theory, 186

C

cable
 install, 174
 remove, 173
 test E5378A cable, 135
 test E5379A cable, 154
calibrating
 see also testing performance
calibration, 119
 strategy, 120
characteristics, 12
 environmental, 12
circuit board
 replace, 176
clean module, 18
cleaning the instrument, 193
comparators, 187
comparators calibration
 test, 133
comparators programming
 test, 132
comparators V offset
 test, 132
configure module, 17
cooling fan, 10
CPLD register, 128
CPU interface, 189

D

data path demux
 test, 132
data path pass-thru
 test, 132
demux data arrays programming
 test, 132

E

EEPROM
 test, 131
environment
 characteristics, 12
 operating, 16
equipment
 test, 13, 22
exchange assemblies, 180
exit test system, 134
eye finder, 43, 84
 adjusting, 43, 84

F

fan
 cooling, 10
features, 2
flowcharts, 123
FPGA
 load test, 128
 register test, 128

G

general information, 9
global arm lines, 131

H

high speed gate array, 188
HW Accelerated Search
 test, 129

I

install
 logic analyzer cable, 174
install module, 17
instrument warm-up, 22
instrument, cleaning the, 193
inter-chip resource bus, 130
inter-module flag bits, 131

L

LA chip calibration
 test, 133
local arm lines, 131

M

mainframe, 10
 fans, 10
 operating system, 123
memory

 address bus test, 128
 analyzer bus SU/H measure, 130
 analyzer chip bus test, 130
 data bus test, 128
 DMA unload test, 129
 HW assisted cell test, 129
 sleep mode test, 129
 unload modes test, 129

module

 clean, 18
 configure, 17
 inspect, 17
 install, 17
 remove, 172
 test, 17
multi-card module, 117
 test, 21

O

one-card module
 test, 21
operating
 environment, 16
 system, 10, 123

P

parts
 ordering, 180
 replaceable, 181
performance test record, 118
power
 requirements, 16
preparing for use, 15
probe ID read
 test, 131
probing, 186

R

remove
 logic analyzer cable, 173
 module, 172
replace
 circuit board, 176
replaceable parts, 179
replacing assemblies, 171
return assemblies, 177

S

self-test, 126
 description, 128
specifications, 11

storage, 16
system
 backplane clock, 130
 operating, 10, 123
 test, 134
 multi-card module, 21
 test record, 118
 theory of operation, 185
 tools required, 172
 troubleshooting, 121

T

test
 ADC, 131
 analyzer chip memory bus, 130
 analyzer memory bus SU/H measure,
 130
 chip registers, 129
 comparators calibration, 133
 comparators programming, 132
 comparators V offset, 132
 CPLD register, 128
 data path demux, 132
 data path pass-thru, 132
 demux data arrays programming, 132
 E5378A cable, 135
 E5379A cables, 154
 EEPROM, 131
 equipment, 13, 22
 FPGA load, 128
 FPGA register, 128
 global and local arm lines, 131
 HW accelerated search, 129
 HW assisted memory cell, 129
 inter-chip resource bus, 130
 inter-module flag bits, 131
 interval, 21
 LA chip calibration, 133
 memory address bus, 128
 memory data bus, 128
 memory DMA unload, 129
 memory sleep mode, 129
 memory unload modes, 129
 module, 17
 multi-card module, 20, 117
 one-card module, 20
 performance record, 118
 probe ID read, 131
 record description, 21
 self-test, 126
 strategy, 20
 system, 134
 system backplane clock, 130
 system clocks, 130
testing performance, 19
 equipment, 13, 22
 interval, 21

Safety Notices

This apparatus has been designed and tested in accordance with IEC Publication 1010, Safety Requirements for Measuring Apparatus, and has been supplied in a safe condition. This is a Safety Class I instrument (provided with terminal for protective earthing). Before applying power, verify that the correct safety precautions are taken (see the following warnings). In addition, note the external markings on the instrument that are described under "Safety Symbols."

Warnings

- Before turning on the instrument, you must connect the protective earth terminal of the instrument to the protective conductor of the (mains) power cord. The mains plug shall only be inserted in a socket outlet provided with a protective earth contact. You must not negate the protective action by using an extension cord (power cable) without a protective conductor (grounding). Grounding one conductor of a two-conductor outlet is not sufficient protection.
- Only fuses with the required rated current, voltage, and specified type (normal blow, time delay, etc.) should be used. Do not use repaired fuses or short-circuited fuseholders. To do so could cause a shock or fire hazard.
- If you energize this instrument by an auto transformer (for voltage reduction or mains isolation), the common terminal must be connected to the earth terminal of the power source.
- Whenever it is likely that the ground protection is impaired, you must make the instrument inoperative and secure it against any unintended operation.
- Service instructions are for trained service personnel. To avoid dangerous electric shock, do not perform any service unless qualified to do so. Do not attempt internal service or adjustment unless another person, capable of rendering first aid and resuscitation, is present.
- Do not install substitute parts or perform any unauthorized modification to the instrument.

- Capacitors inside the instrument may retain a charge even if the instrument is disconnected from its source of supply.

- Do not operate the instrument in the presence of flammable gasses or fumes. Operation of any electrical instrument in such an environment constitutes a definite safety hazard.

- Do not use the instrument in a manner not specified by the manufacturer.

To clean the instrument

If the instrument requires cleaning: (1) Remove power from the instrument. (2) Clean the external surfaces of the instrument with a soft cloth dampened with a mixture of mild detergent and water. (3) Make sure that the instrument is completely dry before reconnecting it to a power source.

Safety Symbols



Instruction manual symbol: the product is marked with this symbol when it is necessary for you to refer to the instruction manual in order to protect against damage to the product.



Hazardous voltage symbol.



Earth terminal symbol: Used to indicate a circuit common connected to grounded chassis.

Notices

© Agilent Technologies, Inc. 2001-2005

No part of this manual may be reproduced in any form or by any means (including electronic storage and retrieval or translation into a foreign language) without prior agreement and written consent from Agilent Technologies, Inc. as governed by United States and international copyright laws.

Manual Part Number

16760-97015, May 2005

Print History

16760-97013, May 2004
16760-97011, August 2003
16760-97009, September 2002
16760-97006, December 2001
16760-97003, May 2001

Agilent Technologies, Inc.
1900 Garden of the Gods Road
Colorado Springs, CO 80907 USA

Restricted Rights Legend

If software is for use in the performance of a U.S. Government prime contract or subcontract, Software is delivered and licensed as "Commercial computer software" as defined in DFAR 252.227-7014 (June 1995), or as a "commercial item" as defined in FAR 2.101(a) or as "Restricted computer software" as defined in FAR 52.227-19 (June 1987) or any equivalent agency regulation or contract clause. Use, duplication or disclosure of Software is subject to Agilent Technologies' standard commercial license terms, and non-DOD Departments and Agencies of the U.S. Government will receive no greater than Restricted Rights as defined in FAR 52.227-19(c)(1-2) (June 1987). U.S. Government users will receive no greater than Limited Rights as defined in FAR 52.227-14 (June 1987) or DFAR 252.227-7015 (b)(2) (November 1995), as applicable in any technical data.

Document Warranty

The material contained in this document is provided "as is," and is subject to being changed, without notice, in future editions. Further, to the maximum extent permitted by applicable law, Agilent disclaims all warranties, either express or implied, with regard to this manual and any information contained herein, including but not limited to the implied warranties of merchantability and fitness for a particular purpose. Agilent shall not be liable for errors or for incidental or consequential damages in connection with the furnishing, use, or performance of this document or of any information contained herein. Should Agilent and the user have a separate written agreement with warranty terms covering the material in this document that conflict with these terms, the warranty terms in the separate agreement shall control.

Technology Licenses

The hardware and/or software described in this document are furnished under a license and may be used or copied only in accordance with the terms of such license.

WARNING

A **WARNING** notice denotes a hazard. It calls attention to an operating procedure, practice, or the like that, if not correctly performed or adhered to, could result in personal injury or death. Do not proceed beyond a **WARNING** notice until the indicated conditions are fully understood and met.

CAUTION

A **CAUTION** notice denotes a hazard. It calls attention to an operating procedure, practice, or the like that, if not correctly performed or adhered to, could result in damage to the product or loss of important data. Do not proceed beyond a **CAUTION** notice until the indicated conditions are fully understood and met.