

Agilent 16451B DIELECTRIC MATERIAL TEST FIXTURE Operation Manual

Manual Change

Agilent Part No. N/A

June 2008

Change 1

Following note is added on the following designated locations.

NOTE

Be careful not to contaminate or not to make a scratch on the surface of the electrode. A scratch or contamination of the electrode's surface sometimes prevents the measured capacitance from falling within the limits shown in "Electrode Adjustment" (Page 3-36). If it happens, replace the scratched/contaminated electrode or contact your nearest Agilent Technologies Sales and Service Office. As long as the measured capacitance falls within the limits, the electrode doesn't need to be replaced or repaired.

Locations:

1. Page 3-29
2. Page 3-37
3. Page 3-41
4. Page 3-44
5. Page 4-8

Change 2

Correct Table 1-2 (Page1-4) as follows.

Compatible Instrument Model	Measurement Frequency Range
4192A LF Impedance Analyzer	5 Hz - 13 MHz
4194A Impedance/Gain-Phase Analyzer	100 Hz - 40 MHz ^{*1}
4263B LCR Meter	100Hz - 100kHz
4268A 120Hz/1kHz Capacitance Meter	120Hz/1kHz
4278A 1 kHz/1 MHz Capacitance Meter	1 kHz/1 MHz
4279A 1 MHz C-V Meter	1 MHz
4284A Precision LCR Meter	20 Hz - 1 MHz
4285A Precision LCR Meter	75kHz - 30MHz
4288A 1 kHz/1 MHz Capacitance Meter	1 kHz/1 MHz
4294A Precision Impedance Analyzer	40Hz - 110MHz ^{*2}
E4980A Precision LCR Meter	20 Hz - 20 MHz

Change 3

Correct the note for table 1-2 in page 1-4.

- *1: The upper frequency of the 4194A is 40 MHz but it is limited to 30 MHz when used with the 16451B.
- *2: The upper frequency of the 4294A is 110 MHz but it is limited to 30 MHz when used with the 16451B.

Change 4

Correct Table 1-3 (Page1-5) as follows.

Instrument Model Number	Correction Function	1m Cable Compensation
4192A	OPEN/SHORT	available
4194A	OPEN/SHORT	available
4263B	OPEN/SHORT/LOAD	available
4268A	OPEN/SHORT/LOAD	available
4278A	OPEN/SHORT/LOAD	available
4279A	OPEN/SHORT/LOAD	available
4284A	OPEN/SHORT/LOAD	available
4285A	OPEN/SHORT/LOAD	available
4288A	OPEN/SHORT/LOAD	available
4294A	OPEN/SHORT/LOAD	available
E4980A	OPEN/SHORT/LOAD	available

Change 5

Correct the text in page 2-3 as follows.

Function

Test fixture for measuring dielectric constant and dissipation factor.

Permits connecting solid materials to the unknown terminals(4-terminal pair configuration) of the 4192A, 4194A, 4263B, 4268A, 4278A, 4279A, 4284A, 4285A, 4288A ,4294A and E4980A.

Change 6

Replace the contents of page 2-4 by the following,

Supplemental Performance Characteristics

This section gives supplemental performance characteristics. Supplemental performance characteristics are not specifications, but are typical characteristics included as additional information for the operator. Supplemental performance characteristics are not guaranteed.

Measurement Accuracy when using contact electrode method

$$\varepsilon_r' \text{ Accuracy } \left(\frac{\Delta \varepsilon_{rm}'}{\varepsilon_{rm}'} \right)$$

$$\tan \delta < 0.1 :$$

$$A_z + 0.04f^2 \varepsilon_{rm}' \varepsilon_0 \frac{\pi \left(\frac{d}{2} \right)^2}{t} + \frac{100(\varepsilon_{rm}' - 1)}{(\varepsilon_{rm}' + \frac{t}{0.01})} \text{ [%] (typical)}$$

Dissipation Factor Accuracy ($\Delta \tan \delta$)

$$\tan \delta < 0.1 : A_d + E_a + E_b$$

$$E_a = 0.005 + 0.0004f^2 \varepsilon_{rm}' \varepsilon_0 \frac{\pi \left(\frac{d}{2} \right)^2}{t} \text{ (typical)}$$

$$E_b = \frac{\tan \delta}{100} \frac{\Delta \varepsilon_{rm}'}{\varepsilon_{rm}'} \text{ (typical)}$$

f: measured frequency [Hz]

f ≤ 30 MHz

ε_{rm}' : measured permittivity

$\tan \delta$: measured dissipation factor

ε_0 : permittivity of air 8.854×10^{-12} [F/m]

d: diameter of electrode {A,B} [m]

t: thickness of material [mm]

A_z : Impedance measurement error of instrument

A_d : D measurement error of instrument

The surfaces of material are assumed to be ideally parallel, flat and smooth.

The above equation is only compatible for electrodes A and B.

Change 7

Correct the sentence at “16451B Overview” in page 3-1.

The 16451B is a test fixture for measuring disc and lm dielectric materials when connected to Agilent’s LCR meters or impedance analyzers, and is usable up to 30 MHz.

Change 8

Correct the sentence of step 8.in Page 3-43.

Keep pressing the Guarded/Guard electrode pressure adjuster shown in Figure 3-25 and turn the three screws in a clockwise sequence until the measured capacitance value is within the limits listed in Table 3-5.

マニュアル チェンジ

Agilent Part No. N/A

June 2008

変更 1

下記脚注を以下に指定するページに追加してください。

記:

電極の表面は汚したりキズをつけることのないよう取り扱いには十分注意してください。電極表面上の汚れやキズによって容量を測定する際、“電極の調節” (Page 3-33) で提示されるリミットの範囲に収まらない可能性が発生します。

このような状況が発生した場合には電極を交換するかお近くのアジレントテクノロジーの営業、もしくはサービスまでお問い合わせください。

容量を測定した際、その測定結果がリミットに収まっている場合には、電極を交換する必要はありません。

追加箇所:

1. Page 3-26
2. Page 3-33 電極の平行度の粗調節の項の前
3. Page 3-37 電極水平置ききの微調節の項の前
4. Page 3-39
5. Page 4-8

変更 2

1-4 ページの 表 1-2 を以下の表に差し替えてください。

適合測定機器	測定周波数
4192A LF Impedance Analyzer	5 Hz - 13 MHz
4194A Impedance/Gain-Phase Analyzer	100 Hz - 40 MHz ^{*1}
4263B LCR Meter	100Hz - 100kHz
4268A 120Hz/1kHz Capacitance Meter	120Hz/1kHz
4278A 1 kHz/1 MHz Capacitance Meter	1 kHz/1 MHz
4279A 1 MHz C-V Meter	1 MHz
4284A Precision LCR Meter	20 Hz - 1 MHz
4285A Precision LCR Meter	75kHz - 30MHz
4288A 1 kHz/1 MHz Capacitance Meter	1 kHz/1 MHz
4294A Precision Impedance Analyzer	40Hz - 110MHz ^{*2}
E4980A Precision LCR Meter	20 Hz - 20 MHz

変更 3

1-4 ページの表 1-2 の脚注を下記に変更してください。

*1: 16451B を使用する際の 4194A の測定周波数の上限は、30 MHz となります。

*2: 16451B を使用する際の 4294A の測定周波数の上限は、30 MHz となります。

変更 4

1-5 ページの 表 1-3 を以下の表に差し替えてください。

Instrument Model Number	Correction Function	1m Cable Compensation
4192A	OPEN/SHORT	available
4194A	OPEN/SHORT	available
4263B	OPEN/SHORT/LOAD	available
4268A	OPEN/SHORT/LOAD	available
4278A	OPEN/SHORT/LOAD	available
4279A	OPEN/SHORT/LOAD	available
4284A	OPEN/SHORT/LOAD	available
4285A	OPEN/SHORT/LOAD	available
4288A	OPEN/SHORT/LOAD	available
4294A	OPEN/SHORT/LOAD	available
E4980A	OPEN/SHORT/LOAD	available

変更 5

2-3 ページ 下記箇所を下記文章に変更してください。

機能:

誘電率および誘電正接測定用テストフィクスチャ

4192A, 4194A, 4263B, 4268A, 4278A, 4279A, 4284A, 4285A, 4288A, 4294A and E4980A の測定端子(4 端子対構成)に固体試料を接続することを可能とする。

周波数範囲: ≤ 30 MHz

変更 6

6-1: 2-7 ページの表 2-1 を下記に変更してください。

使用主電極	試料直径	試料厚さ	主電極直径
A	$\Phi 40 \sim 56$ mm	≤ 10 mm	$\Phi 38$ mm
B	$\Phi 10 \sim 56$ mm	≤ 10 mm	$\Phi 5$ mm
C	$\Phi 56$ mm	≤ 10 mm ^{*1}	$\Phi 5 \sim 50$ mm ^{*2}
D	$\Phi 20 \sim 56$ mm	≤ 10 mm ^{*1}	$\Phi 5 \sim 14$ mm ^{*2}

*1: 薄膜電極厚を含む

*2: 薄膜電極直径

6-2: 2-4 ページ 測定確度の項に下記を追加してください。

$$\varepsilon'_{\text{r m}} \text{ 確度 } \left(\frac{\Delta \varepsilon'_{\text{r m}}}{\varepsilon'_{\text{r m}}} \right)$$

$\tan \delta < 0.1$:

$$A_z + 0.04 f^2 \varepsilon'_{\text{r m}} \varepsilon_0 \left(\frac{\pi \left(\frac{d}{2} \right)^2}{t} \right) + \frac{100(\varepsilon'_{\text{r m}} - 1)}{(\varepsilon'_{\text{r m}} + \frac{t}{0.01})} \quad [\%]$$

ε * の損失確度 ($\Delta \tan \delta$)

$\tan \delta < 0.1$: $A_d + E_a + E_b$

$$E_a = 0.005 + 0.0004 f^2 \varepsilon'_{\text{r m}} \varepsilon_0 \left(\frac{\pi \left(\frac{d}{2} \right)^2}{t} \right)$$

$$E_b = \frac{\tan \delta}{100} \frac{\Delta \varepsilon'_{\text{r m}}}{\varepsilon'_{\text{r m}}}$$

f : 測定周波数 [Hz]

$f \leq 30\text{MHz}$

$\varepsilon'_{\text{r m}}$: 比誘電率の測定値

$\tan \delta$: 損失計数の測定値

ε_0 : 真空の誘電率 8.854×10^{-12} [F/m]

d : 電極の直径 (A, B) [m]

t : 試料の厚さ [mm]

A_z : 測定器のインピーダンス測定誤差

A_d : 測定器の損失測定確度

電極 A と電極 B だけに対応する確度を表す。

被測定材料の両面が理想的に平行・平坦で滑らかであることを前提とする。

4294Aを用いた時の誘電率、誘電正接測定精度（参考値）

電極A、試料厚み：1mmの時

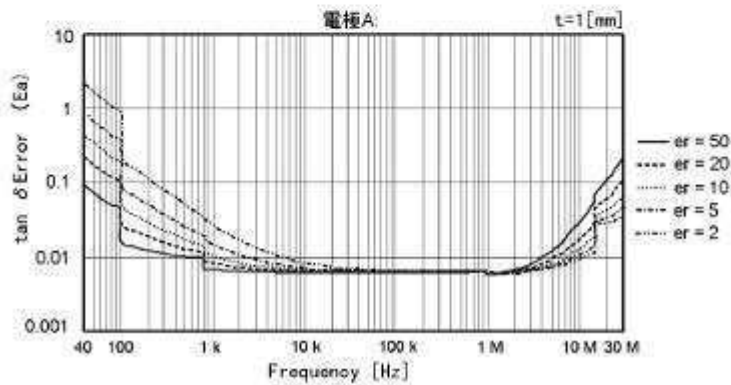
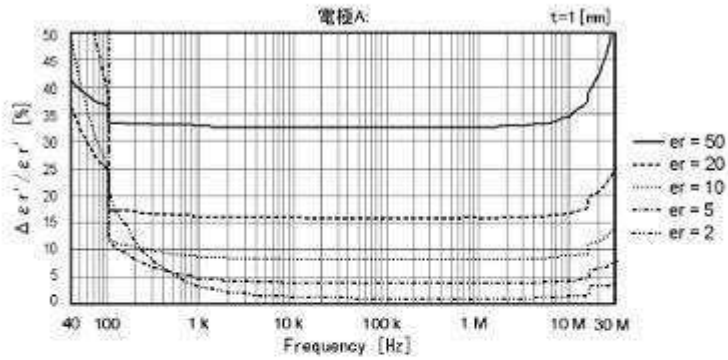

電極B、試料厚み：1mmの時

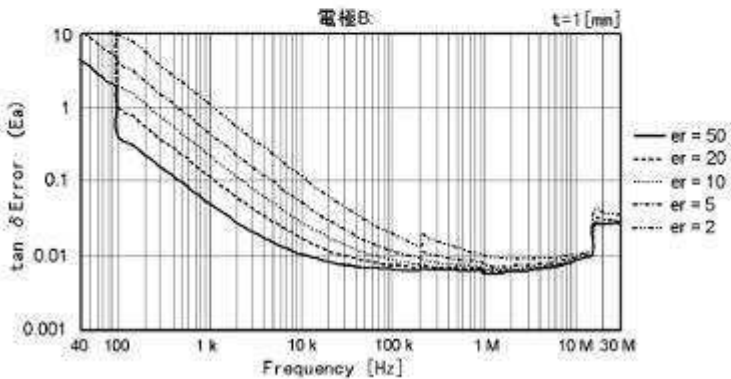
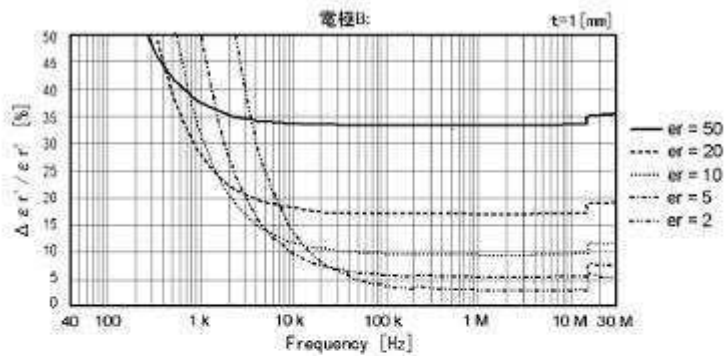

4294A の設定条件

1. 信号レベル: 500 mV
2. BW: 5
3. ケーブル長: 1m
4. 補正: オープン/ショート/ロード

変更 7

3 章 16451B の概要のテキストを以下に変更してください。

16451B の概要

16451B は、Agilent 製 LCR メータやインピーダンス・アナライザに接続して、板状およびフィルム状の誘電材料を測定するためのテスト・フィクスチャで最高 30MHz までの周波数で使用できます。

16451B はフィクスチャ・アセンブリと 4 種の交換可能なガード付主電極、および誤差補正用治具によって構成されています。図3-1は 16451B のフィクスチャ・アセンブリを、図3-2は 16451B に付属しているアクセサリを示しています。

MANUAL CHANGES

Agilent 16451B DIELECTRIC TEST FIXTURE

Operation and Service Manual

MANUAL IDENTIFICATION

Model Number: 16451B Date Printed: Oct. 2000 Part Number: 16451-90020

This supplement contains information for correcting manual errors and for adapting the manual to newer instruments that contains improvements or modifications not documented in the existing manual.

To use this supplement

1. Make all ERRATA corrections
2. Make all appropriate serial-number-related changes listed below

SERIAL PREFIX OR NUMBER	MAKE MANUAL CHANGES
2916J	1
JP1KH	2

◆ New Item

SERIAL PREFIX OR NUMBER	MAKE MANUAL CHANGES

CHANGES 1

Correct the Part Number as follows:

Page 4-3, Table 4-1. Replaceable Parts List (1 of 5)

Reference
Designator

CHANGES 2

Change the Part Number as follows:

Page 4-3, Table 4-1. Replaceable Parts List (1 of 5)

Reference Designator	16451-25025	1	Insulator
9	16451-24018	1	Plate

Page 4-4, Table 4-2. Replaceable Parts List (2 of 5)

Reference
Designator

Page 4-5, Table 4-3. Replaceable Parts List (3 of 5)

Reference
Designator

Agilent 16451B DIELECTRIC TEST FIXTURE OPERATION AND SERVICE MANUAL

SERIAL NUMBERS

This manual applies directly to instruments with serial number prefix 2916J.

For additional important information about serial numbers, read Chapter 2, "Serial Number" of this Operation and Service Manual.



Agilent Technologies

Agilent Part No. 16451-90020
Printed in JAPAN October 2000

Notice

The information contained in this document is subject to change without notice.

This document contains proprietary information which is protected by copyright. All rights are reserved. No part of this document may be photocopied, reproduced, or translated to another language without the prior written consent of the Agilent Technologies.

Agilent Technologies Japan, Ltd.
Component Test PGU-Kobe
1-3-2, Murotani, Nishi-ku, Kobe-shi,
Hyogo, 651-2241 Japan

© Copyright 1989, 1992, 1993, 1999, 2000
Agilent Technologies Japan, Ltd.

Manual Printing History

The manual printing date and part number indicate its current edition. The printing date changes when a new edition is printed. (Minor corrections and updates which are incorporated at reprint do not cause the date to change.) The manual part number changes when extensive technical changes are incorporated.

December 1989 First Edition (part number: 16451-90000)
May 1992 Second Edition (part number: 16451-90000)
December 1993 Third Edition (part number: 16451-90010)
December 1999 Fourth Edition (part number: 16451-90010)
October 2000 Fifth Edition (part number: 16451-90020)

Safety Summary

The following general safety precautions must be observed during all phases of operation, service, and repair of this fixture. Failure to comply with these precautions or with specific **WARNINGS** given elsewhere in this manual violates safety standards of design, manufacture, and intended use of the fixture.

The Agilent Technologies assumes no liability for the customer's failure to comply with these requirements.

DO NOT Operate In An Explosive Atmosphere

Do not operate the fixture in the presence of flammable gasses or fumes. Operation of any electrical instrument in such an environment constitutes a safety hazard.

DO NOT Substitute Parts Or Modify Instrument

Because of the danger of introducing additional hazards, do not substitute parts or perform unauthorized modifications to the fixture. Return the fixture to a Agilent Technologies Sales and Service Office for service and repair to ensure the safety features are maintained.

Dangerous Procedure Warnings

Warnings, such as the example below, precede potentially dangerous procedures throughout this manual. Instructions contained in the warnings must be followed.

Warning



Dangerous voltages, capable of causing death, are present in this fixture. Use extreme caution when handling, testing, and adjusting this fixture.

Safety Symbols

General definitions of safety symbols used on equipment or in manuals.

Warning



Warning denotes a hazard. It calls attention to a procedure, practice, condition or the like, which, if not correctly performed or adhered to, could result in injury or death to personnel.

Caution



Caution sign denotes a hazard. It calls attention to a procedure, practice, condition or the like, which, if not correctly performed or adhered to, could result damage to or destruction of part or all of the product.

Note



Note denotes important information. It calls attention to a procedure, practice, condition or the like, which is essential to highlight.

How To Use This Manual

This is the Operation Manual for the 16451B Dielectric Test Fixture, containing information on installation, configuration, operation, and service in the following four chapters and six appendices. After you receive your 16451B, begin with Chapter 1.

The 16451B is designed to measure a dielectric using Agilent Technologies's LCR meters or impedance analyzers. For more information to operate an instrument, refer to the Operation Manual of your instrument before reading this Operation Manual.

Chapter 1 Installation

This chapter provides, initial inspection, and preparation information necessary for you to know before you connect the 16451B to an instrument.

Chapter 2 General Information

This chapter provides specifications, supplemental performance characteristics, and other general information on the 16451B.

Chapter 3 Operation

This chapter provides basic operation procedures with measurement techniques and practical measurement examples.

Chapter 4 Service

This chapter provides 16451B parts replacement and troubleshooting information.

Appendix A Manual Changes

Appendix A contains the Manual Changes and provides information for using this manual with a 16451B manufactured before this manual's printing date.

Appendix B Recommended Capacitance Range

Appendix B shows the recommended capacitance range of test materials when using the 16451B.

Appendix C Error Correction Procedure

Appendix C shows error correction procedures to perform the OPEN/SHORT/LOAD correction when using the 16451B with a compatible instrument.

Appendix D Sample Program

Appendix D lists a sample ASP (Auto Sequence Program) program for the 4194A and a BASIC program for the 4284A to get the dielectric constant.

Appendix E Bibliography

Appendix E lists the names of reference (standards) for dielectric constant measurement.

Typeface Conventions

Bold	Boldface type is used when a term is defined. For example: icons are symbols.
<i>Italics</i>	Italic type is used for emphasis and for the titles of manuals and other publications. Italic type is also used for keyboard entries when a name or a variable must be typed in place of the words in italics. For example: copy <i>filename</i> means to type the word copy, to type a space, and then to type the name of a file such as file1.
Computer	Computer font is used to represent BASIC control program examples. Computer type is also used for on-screen prompts and messages.
HARDKEYS	Labeled keys on the fixture front panel are enclosed in boxes with boldface □ .
SOFTKEYS	Softkeys located to the right of the display of an instrument are enclosed in □ .

Warranty

This Agilent Technologies fixture is warranted against defects in material and workmanship for a period of one year from the date of shipment, except that in the case of certain components listed in Chapter 1 of this manual, the warranty shall be for the specified period. During the warranty period, Agilent Technologies will, at its option, either repair or replace products which prove to be defective.

For warranty service or repair, this product must be returned to a service facility designated by Agilent Technologies. The buyer shall prepay shipping charges to Agilent Technologies and Agilent Technologies shall pay shipping charges to return the product to the buyer. However, the buyer shall pay all shipping charges, duties, and taxes for products returned to Agilent Technologies from another country.

Limitation Of Warranty

The foregoing warranty shall not apply to defects resulting from improper or inadequate maintenance by the buyer, buyer-supplied software or interfacing, unauthorized modification or misuse, operation outside of the environmental specifications for the product, or improper site preparation or maintenance.

No other warranty is expressed or implied. Agilent Technologies specifically disclaims the implied warranties of merchantability and fitness for a particular purpose.

Exclusive Remedies

The remedies provided herein are buyer's sole and exclusive remedies. Agilent Technologies shall not be liable for any direct, indirect, special, tract, tort, or any other legal theory.

Assistance

Product maintenance agreements and other customer assistance agreements are available for Agilent Technologies products.

For any assistance, contact your nearest Agilent Technologies Sales and Service Office. Address are provided at the back of this manual.

Contents

1. Installation	
Introduction	1-1
Product Description	1-1
Initial Inspection	1-2
Compatible Measurement Instruments	1-4
Error Correction	1-4
2. General Information	
Introduction	2-1
Safety Considerations	2-1
Serial Number	2-2
Specifications	2-3
Function	2-3
Frequency Range	2-3
Applicable Voltage Range	2-3
Cable Length (setting)	2-3
Operating Temperature	2-3
Operating Humidity	2-3
Weight	2-3
Furnished Accessories and Quantity	2-3
Supplemental Performance Characteristics	2-4
Measurement Accuracy when using contact electrode method	2-4
Permittivity Measurement Accuracy including 4294A (Supplemental Characteristics)	2-5
Electrode Dimensions	2-7
Guarded/Guard Electrode (4 types, changeable)	2-7
Unguarded Electrode	2-9
Available Test Material Dimensions	2-9
Micrometer Resolution	2-10
Dimensions of Fixture Assembly	2-10
Storage and Repacking	2-11
Environmental Requirements	2-11
Original Packaging	2-11
Other Packaging	2-11

3. Operation	
Introduction	3-1
16451B Overview	3-1
Fixture Assembly	3-1
Furnished Accessories	3-4
Dielectric Measurement Basic	3-6
Basic theory	3-6
Guard Electrode	3-8
Measurement Method	3-9
Contacting Electrode Method (used with	
Rigid Metal Electrode)	3-11
Principle	3-11
Electrodes of the 16451B	3-13
Applicable Size of Test Material for Electrode-A	
(38 mm Guarded/Guard Electrode)	3-14
Applicable Size of Test Material for Electrode-B	
(5 mm Guarded/Guard Electrode)	3-15
Contacting Electrode Method (used with	
Thin Film Electrode)	3-16
Principle	3-16
Thin Film Electrode	3-17
Electrodes of the 16451B	3-18
Applicable Size of Test Material for Electrode-C	
(Guarded/Guard Electrode for Large Thin Film	
Electrode)	3-19
Applicable Size of Test Material Electrode-D	
(Guarded/Guard Electrode for Small Thin Film	
Electrodes)	3-20
Non-contacting Electrode Method (Air Gap Method)	3-21
Principle	3-21
Electrodes of the 16451B	3-23
Applicable Size of Test Material for Electrode-A	
(38 mm Guarded/Guard Electrode)	3-24
Applicable Size of Test Material for Electrode-B	
(5 mm Guarded/Guard Electrode)	3-25
Preparation of Test Material	3-26
Shape and Size of Test Material	3-26
Thickness of Test Material	3-26
Flatness of Test Material's Surface	3-27
Thin Film Electrode	3-27
Connecting to the Instrument	3-28
Changing the Guarded/Guard Electrode	3-28
Error Correction	3-30
Open Correction (ZERO OPEN Offset Adjustment)	3-30
Short Correction (ZERO SHORT Offset Adjustment)	3-32
For Electrode-A and Electrode-B (Rigid Metal	
Electrode)	3-32
For Electrode-C and Electrode-D (Electrode for Thin	
Film Electrodes)	3-34
LOAD Correction (LOAD Compensation)	3-35
Electrode Adjustment	3-36
Rough Adjustment to Make Electrodes Parallel	3-38
Accurate Adjustment to Make Electrodes Parallel	3-40
Accurate Adjustment in Vertical Position	3-40
Accurate Adjustment in Horizontal Position	3-42

Typical Measurement Procedure by the Measurement Methods	3-45
Contacting Electrode Method	3-45
Procedure	3-46
Equations	3-48
Non-Contacting Electrode Method	3-49
Procedure	3-49
Equations	3-50
Check Electrode Parallelism	3-51
Measurement Examples	3-52
Using the 4194A	3-52
Using the 4284A	3-55
Measurement Error Analysis	3-57
Error Factor using Contacting Electrode Method	3-57
Capacitance measurement Error	3-57
Tolerance of Guarded Electrode Diameter	3-58
Gap Error	3-58
Effective Area of Electrode	3-59
Error Factor using Non-contacting Electrode Method	3-62
Capacitance measurement Error	3-62
Gap Error	3-62
Compensation Result Example	3-64
Effective Area of Electrode	3-64
4. Service	
Introduction	4-1
Assembly Replacement	4-1
Assembly and Disassembly Hints	4-1
Slide Stand Assembly	4-1
Micrometer Stand Replacement	4-2
Micrometer Replacement	4-2
Replaceable Parts List	4-3
Troubleshooting	4-8
Mechanical Trouble	4-8
Electrical Trouble	4-8
Operation Check	4-8
A. Manual Changes	
Introduction	A-1
Manual Changes	A-1
B. Recommended Capacitance Range	
Using Electrode-A (ϕ 38 mm electrode)	B-1
Using Electrode-C (ϕ 5 mm electrode)	B-2
C. Correction Procedure	
4192A	C-1
4194A	C-2
4274A and 4275A	C-3
4276A and 4277A	C-4
4278A	C-5
4284A	C-6

D. Sample program	
Sample ASP Program for the 4194A	D-1
Sample Program for the 4284A	D-2
E. Bibliography	
Index	

Figures

1-1. Product Overview	1-3
2-1. Serial Number Plate	2-2
2-2. Electrode A, MUT Thickness: 1mm	2-5
2-3. Electrode B, MUT Thickness: 1mm	2-6
2-4. Dimensions of Electrode-A	2-7
2-5. Dimensions of Electrode-B	2-7
2-6. Dimensions of Electrode-C	2-8
2-7. Dimensions of Electrode-D	2-8
2-8. Dimensions of Unguarded Electrode	2-9
2-9. Dimensions of Test Fixture Assembly	2-10
3-1. Fixture Assembly	3-2
3-2. Furnished Accessories	3-4
3-3. Basic Model for Dielectric Measurement	3-6
3-4. Capacitance Measurement using Unguarded Electrode System	3-8
3-5. Capacitance Measurement using Guarded Electrode System	3-8
3-6. Summary of Measurement Methods	3-10
3-7. Contacting Electrode Method (Rigid Metal Electrode)	3-11
3-8. Electrode of the 16451B for Contacting Electrode Method (Rigid Metal Electrode)	3-13
3-9. Applicable Size of Test Material for Electrode-A	3-14
3-10. Applicable Size of Test Material for Electrode-B	3-15
3-11. Contacting Electrode Method (Thin Film Electrode)	3-16
3-12. Electrode of the 16451B for Contacting Electrode Method (Thin Film Electrode)	3-18
3-13. Applicable Size of Test Material for Electrode-C	3-19
3-14. Applicable Size of Test Material for Electrode-D	3-20
3-15. Non-contacting method (Air Gap method)	3-21
3-16. Electrode of the 16451B for Non-Contacting Electrode Method (Air Gap Method)	3-23
3-17. Applicable Size of Test Material for Electrode-A	3-24
3-18. Applicable Size of Test Material for Electrode-B	3-25
3-19. Screw Position to Attach Guarded/Guard Electrode	3-28
3-20. Connecting the Attachment to the Guarded/Guard Electrode for OPEN Correction	3-30
3-21. OPEN Correction	3-31
3-22. Connecting the Attachment to the Unguarded Electrode for SHORT Correction	3-32
3-23. SHORT Correction for Rigid Metal Electrode	3-33
3-24. SHORT Correction for Thin Film Electrodes	3-34
3-25. Vertical Position and Electrode Adjustment Screws	3-38
3-26. Rough Adjustment Procedure	3-39
3-27. Vertical Position	3-40
3-28. The Micrometer Scale Adjusted to 0.01 mm	3-41
3-29. Horizontal Position	3-42

3-30. Contacting Electrode Method (Rigid Metal Electrode) . . .	3-46
3-31. Contacting Electrode Method (Thin Film Electrode) . . .	3-46
3-32. Non-Contacting Electrode Method (Air Gap Method) . . .	3-49
3-33. Sample Result of Cp-D Measurement Using the 4194A . . .	3-54
3-34. Sample Result of Dielectric Constant Using the 4194A . . .	3-54
3-35. Airgap Effects	3-59
4-1. Slide Stand Assembly	4-1
4-2. Micrometer Stand Replacement	4-2
4-3. Micrometer Replacement	4-2
4-4. Cable Connection Diagram	4-9
B-1. Recommended Capacitance Range Using Electrode-A . . .	B-1
B-2. Recommended Capacitance Range Using Electrode-B . . .	B-2

Tables

1-1. Contents	1-3
1-2. Measurement Frequency Range of Compatible Instruments	1-4
1-3. Correction Functions of the Compatible Instruments	1-5
2-1. Available Test Material Dimensions	2-9
3-1. Name of Fixture Assembly	3-3
3-2. Name of Furnished Accessories	3-5
3-3. Measured Capacitance Limits When the Micrometer is Set to 0.01 mm	3-41
3-4. Capacitance Point for Starting to Press the Pressure Adjuster	3-43
3-5. Capacitance Limits at Vertical Position	3-43
3-6. Capacitance Limits at Horizontal Position	3-43
3-7. Measured Capacitance Limits for Check Electrode Parallelism	3-51
3-8. Tolerance of Electrode Diameter	3-58
3-9. Measurement Error Caused by Airgap	3-59
3-10. Effective Area Constant	3-61
3-11. Compensation Result Example	3-64
4-1. Replaceable Parts List (1 of 5)	4-3
4-2. Replaceable Parts List (2 of 5)	4-4
4-3. Replaceable Parts List (3 of 5)	4-5
4-4. Replaceable Parts List (4 of 5)	4-6
4-5. Replaceable Parts List (5 of 5)	4-7
A-1. Manual Changes by Serial Number	A-1

Installation

Introduction

This chapter provides the information necessary for receiving and performing an incoming inspection, and preparing the 16451B for use.

The *WARNINGS*, *CAUTIONS*, and *NOTES* given throughout this document must be carefully followed to ensure the operator's safety and to not damage the 16451B.

Product Description

The 16451B is a Dielectric Test Fixture used with LCR meters and impedance analyzers for accurate measurement of insulating and dielectric materials. The 16451B can be used with LCR meters and impedance analyzers which use the 4-terminal pair measurement configuration.

Initial Inspection

This fixture has been carefully inspected electrically and mechanically before being shipped from the factory. It should be in perfect condition, no scratches, dents or the like, and it should be in perfect electrical condition. Verify this by carefully performing an incoming inspection to check the fixture for signs of physical damage and missing contents. If any discrepancy is found, notify the carrier and Agilent Technologies. Your Agilent Technologies sales office will arrange for repair and replacement without waiting for the claim to be settled.

1. Inspect the shipping container for damage, and keep the shipping materials until the inspection is completed.
2. Verify that the shipping container contains everything shown in Figure 1-1 and listed in Table 1-1 of this Operation and Service Manual.
3. Inspect the exterior of the 16451B for any signs of damage.

The Electrode-A (38 mm electrode) and the Unguarded electrode are installed on the test fixture when the 16451B is shipped from the factory.

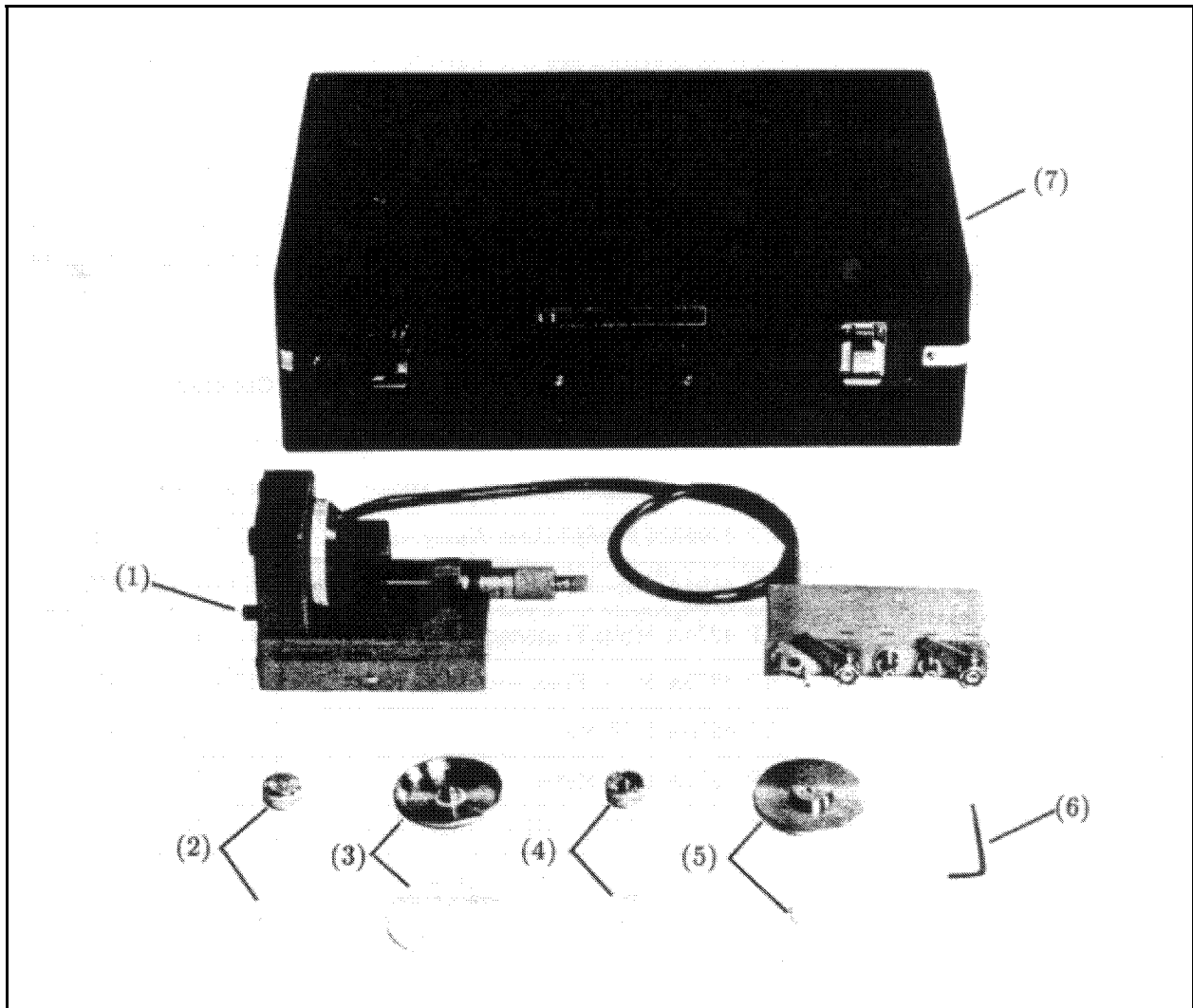

Figure 1-1. Product Overview

Table 1-1. Contents

No.	Description	Agilent Part Number	QTY
(1)	Test Fixture (with Electrode-A, Unguarded electrode and covers)	PN 16451-61001	1
(2)	Electrode-B and cover	PN 16451-60013	1
(3)	Electrode-C and cover	PN 16451-60012	1
(4)	Electrode-D and cover	PN 16451-60014	1
(5)	Attachment for error compensation and cover	PN 16451-60021	1
(6)	Hex key (for replacing electrodes)	PN 8710-1181	1
(7)	Carrying Case	PN 16451-60001	1

The Electrode-A and the Unguarded electrode are installed on the test fixture when the 16451B is shipped from the factory.

Compatible Measurement Instruments

This section specifies the compatible instruments used with the 16451B and their measurement frequency ranges and error correction functions. You should choose an instrument while considering measurement frequency range, capacitance measurement accuracy, error function, etc. Table 1-2 lists the measurement frequency ranges for these instruments when they are used with the 16451B. For more information, refer to the technical data sheet of each instrument.

Table 1-2.
Measurement Frequency Range of Compatible Instruments

Compatible Instrument Model	Measurement Frequency Range
4192A LF Impedance Analyzer	5 Hz - 13 MHz
4194A Impedance/Gain-Phase Analyzer	100 Hz - 15 MHz ^{*1}
4263B LCR Meter	100Hz - 100kHz
4268A 120Hz/1kHz Capacitance Meter	120Hz/1kHz
4278A 1 kHz/1 MHz Capacitance Meter	1 kHz/1 MHz
4279A 1 MHz C-V Meter	1 MHz
4284A Precision LCR Meter	20 Hz - 1 MHz
4285A Precision LCR Meter	75kHz - 30MHz
4294A Precision Impedance Analyzer	40Hz - 110MHz ^{*2}

^{*1} The upper frequency of the 4194A is 40 MHz but it is limited to 30 MHz when used with the 16451B.

^{*2} The upper frequency of the 4294A is 110 MHz but it is limited to 15 MHz when used with the 16451B.

Error Correction

Each of the compatible instruments has the error correction function to correct error due to a test fixture. Table 1-3 lists error correction functions of these instruments. The names of the OPEN/SHORT/LOAD error corrections do not match between instruments, but the performance is the same. LOAD correction can reduce the error such as a negative D (dissipation factor) value, which can not reduced by OPEN/SHORT correction. When the above-mentioned error is occurred (a test material whose dissipation factor is very small is measured), use the instrument which provides the LOAD correction function.

**Table 1-3.
Correction Functions of the Compatible Instruments**

Instrument Model Number	Correction Function	1 m Cable Compensation
4192A	OPEN/SHORT	available
4194A	OPEN/SHORT	available
4263B	OPEN/SHORT/LOAD	available
4268A	OPEN/SHORT/LOAD	available
4278A	OPEN/SHORT/LOAD ^{*1}	available
4279A	OPEN/SHORT/LOAD	available
4284A	OPEN/SHORT/LOAD ^{*1}	available
4285A	OPEN/SHORT/LOAD	available
4294A	OPEN/SHORT/LOAD	available

^{*1} A working standard is required to perform the LOAD compensation.

General Information

Introduction

This chapter describes safety consideration, serial number, specifications, supplemental performance characteristics, and information on storing and repacking the 16451B.

Note



In this manual, the term **dielectric constant** means “relative dielectric constant”. In common usage the word “relative” is frequently dropped. The term “dielectric constant” is often called “permittivity” in other documents. This manual will unify it to “dielectric constant”.

Safety Considerations

The 16451B conforms to the safety requirements of an IEC (International Electrotechnical Commission) Publication-348 (1971) Safety Class 1 instrument and is shipped from the factory in a safe condition.

Serial Number

A serial number is stamped on the serial number plate, as shown in Figure 2-1, attached to the 16451B. The serial number used by Agilent Technologies consists of ten characters. The characters are separated into two sections. The first four digits and a letter are the serial number prefix, and the last five digits are the suffix. The prefix is the same for all identical 16451B's; it changes only when a change is made to the 16451B. The letter placed between the two sections identifies the country where the 16451B was manufactured. The suffix is assigned sequentially and is different for each 16451B.



Figure 2-1. Serial Number Plate

The contents of this manual applies to 16451B's with a serial number prefix(es) listed under the serial numbers on the title page. An 16451B manufactured after the printing of this manual may have a serial number prefix that is not listed on the title page. This unlisted serial number prefix indicates the 16451B is different from those described in this manual. The manual for this new 16451B may be accompanied by a yellow Manual Change supplement or have a different manual part number. The Manual Change Sheet contains "change information" that explains how to adapt manual to a newer 16451B.

In addition to change information, the supplement may contain information for correcting errors (Errata) in the manual. To keep this manual as current and accurate as possible, Agilent Technologies recommends that you periodically request the latest Manual Changes supplement. The supplement for this manual is identified by this manual's printing date and its part number, both of which appear on the manual's title page. Complimentary copies of the supplement are available from Agilent Technologies. If the serial prefix or number of a 16451B is lower than that on the title page of this manual, see *Appendix A, Manual Changes*.

For information concerning a serial number prefix not listed on the title page or in the Manual Change supplement, contact the nearest Agilent Technologies office.

Specifications

This section lists the complete 16451B specifications. These specifications are the performance standards and limits against which the 16451B is tested. When shipped from the factory, the 16451B meets the specifications listed in this section.

Function	Test fixture for measuring dielectric constant and dissipation factor. Permits connecting solid materials to the unknown terminals (4-terminal pair configuration) of the 4192A, 4194A, 4263B, 4268A, 4278A, 4279A, 4284A, 4285A and 4294A.
Frequency Range	≤30 MHz
Applicable Voltage Range	±42 V peak max (AC + DC)
Cable Length (setting)	1 m
Operating Temperature	0°C to 55 °C
Operating Humidity	≤95% RH (40°C)
Weight	3.7 kg (including accessories)

Furnished Accessories and Quantity

Description	Quantity
Attachment for error compensation	1
Different size guarded/guard electrodes	3
Hex key for replacing electrodes	1
Carrying case	1
Operation Manual	1

Supplemental Performance Characteristics

Measurement Accuracy when using contact electrode method

This section gives supplemental performance characteristics. Supplemental performance characteristics are not specifications, but are typical characteristics included as additional information for the operator. Supplemental performance characteristics are not guaranteed.

$$\varepsilon_r' \text{Accuracy} \left(\frac{\Delta \varepsilon_{rm}'}{\varepsilon_{rm}'} \right)$$

$$\tan \delta < 0.1 :$$

$$A_z + 0.04f^2 \varepsilon_{rm}' \varepsilon_0 \frac{\pi \left(\frac{d}{2} \right)^2}{t} + \frac{100(\varepsilon_{rm}' - 1)}{(\varepsilon_{rm}' + 0.01)} \text{ [%] (typical)}$$

$$\tan \delta < 0.1 : A_d + E_a + E_b$$

$$E_a = 0.005 + 0.0004f^2 \varepsilon_{rm}' \varepsilon_0 \frac{\pi \left(\frac{d}{2} \right)^2}{t} \text{ (typical)}$$

$$E_b = \frac{\tan \delta}{100} \frac{\Delta \varepsilon_{rm}'}{\varepsilon_{rm}'} \text{ (typical)}$$

f: measured frequency [Hz]

f ≤ 30 MHz

ε_{rm}' : measured permittivity

$\tan \delta$: measured dissipation factor

ε_0 : permittivity of air 8.854×10^{-12} [F/m]

d: diameter of electrode {A,B}

t: thickness of material [mm]

A_z : Impedance measurement error of instrument

A_d : D measurement error of instrument

The material is assumed to be ideally flat. The above equation is only compatible for electrodes A and B.

**Permittivity Measurement Accuracy including 4294A
(Supplemental Characteristics)**

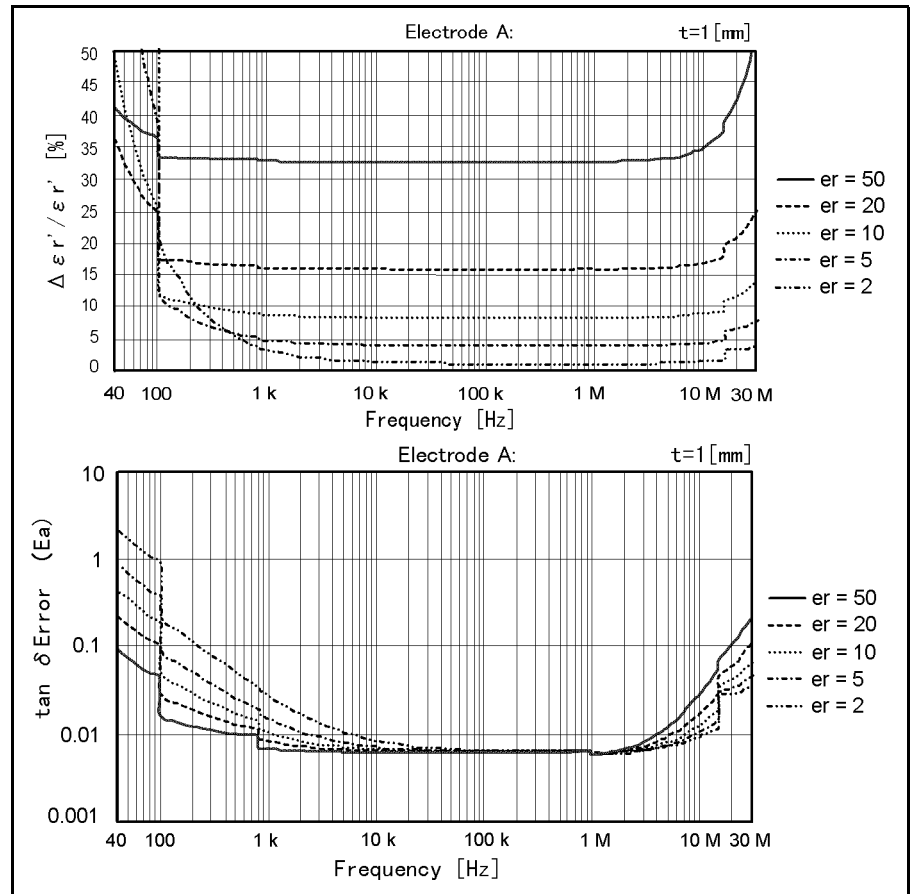

Figure 2-2. Electrode A, MUT Thickness: 1mm

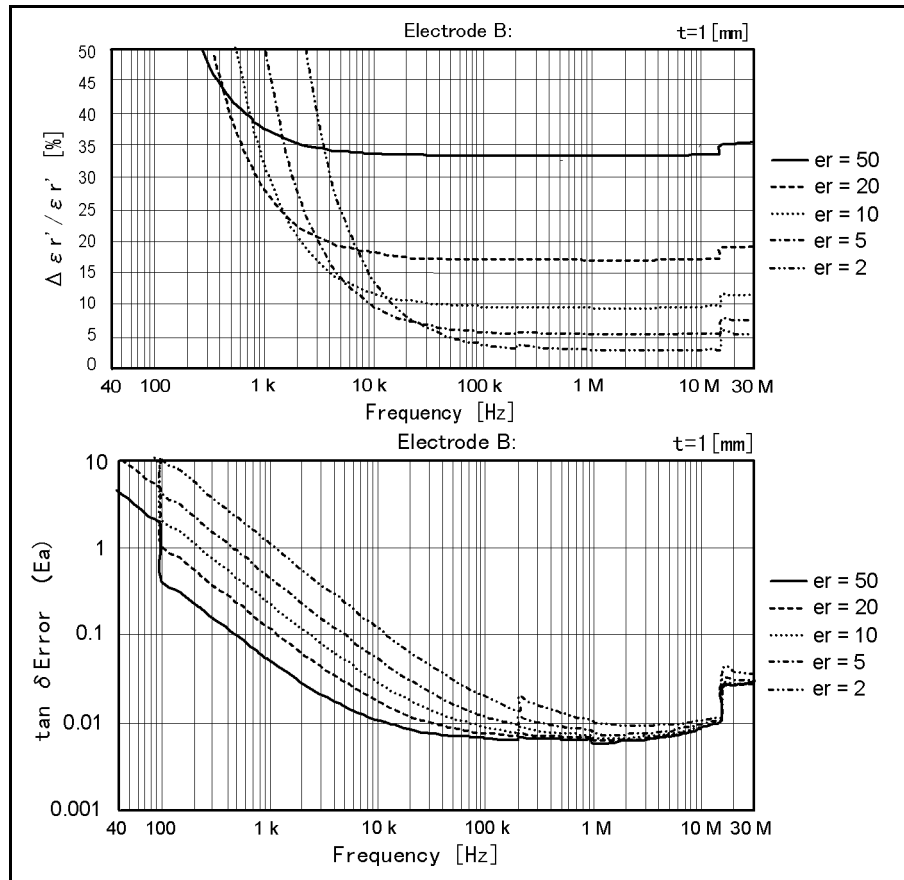

Figure 2-3. Electrode B, MUT Thickness: 1mm

1. OSC LEVEL: 500 mV
2. BW: 5
3. ADAPTER TYPE: 4TP_1M
4. COMPENSATION: OPEN,SHORT & LOAD

Electrode Dimensions

Guarded/Guard Electrode (4 types, changeable)

1. For materials without applied thin film electrodes

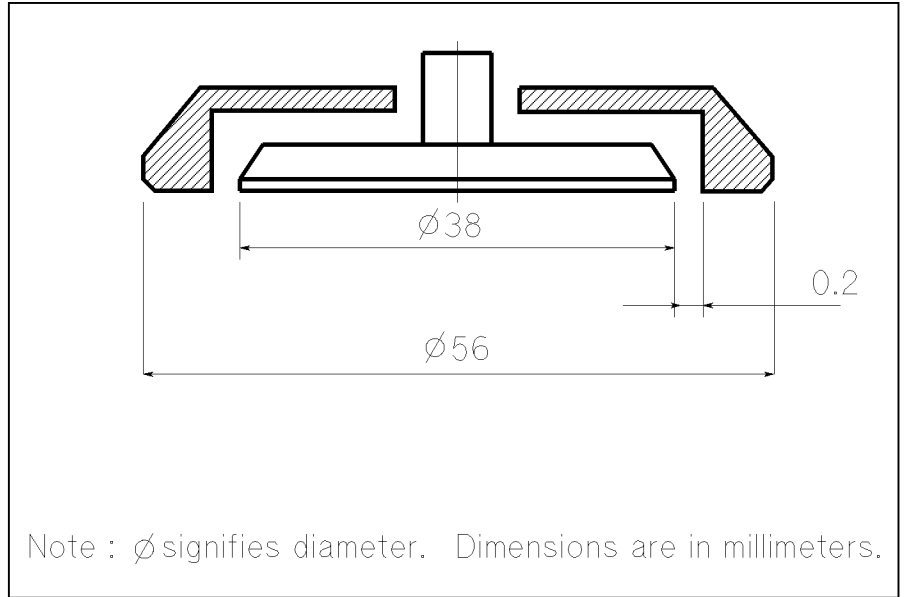

A6002001

Figure 2-4. Dimensions of Electrode-A

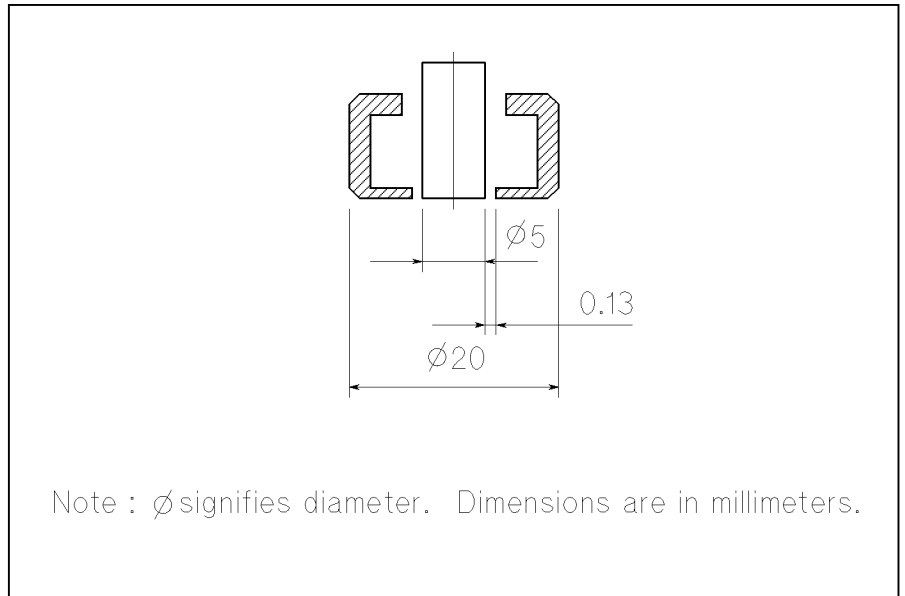

A6002002

Figure 2-5. Dimensions of Electrode-B

2. For materials with applied thin film electrodes

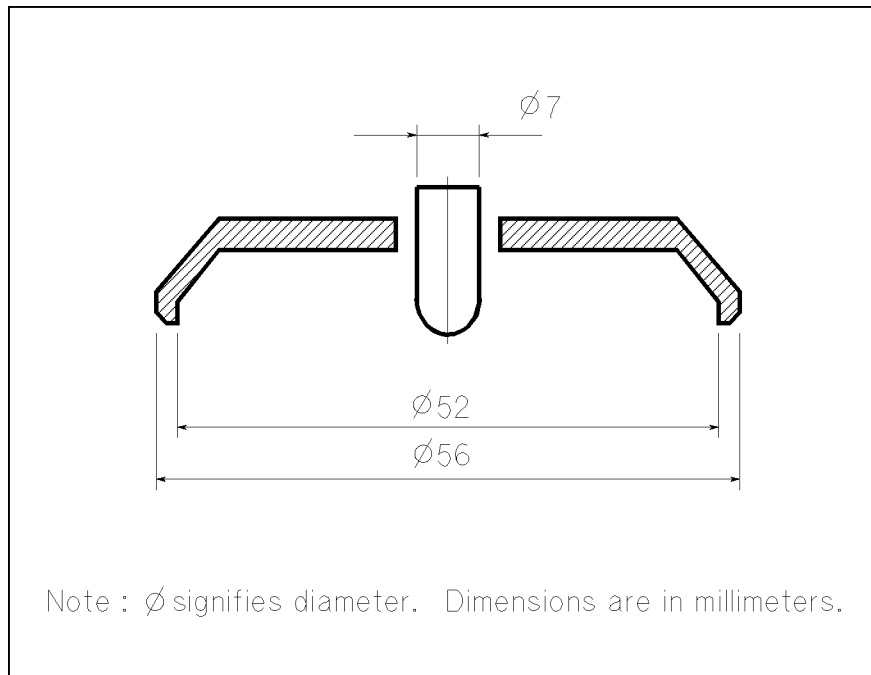

A6002003

Figure 2-6. Dimensions of Electrode-C

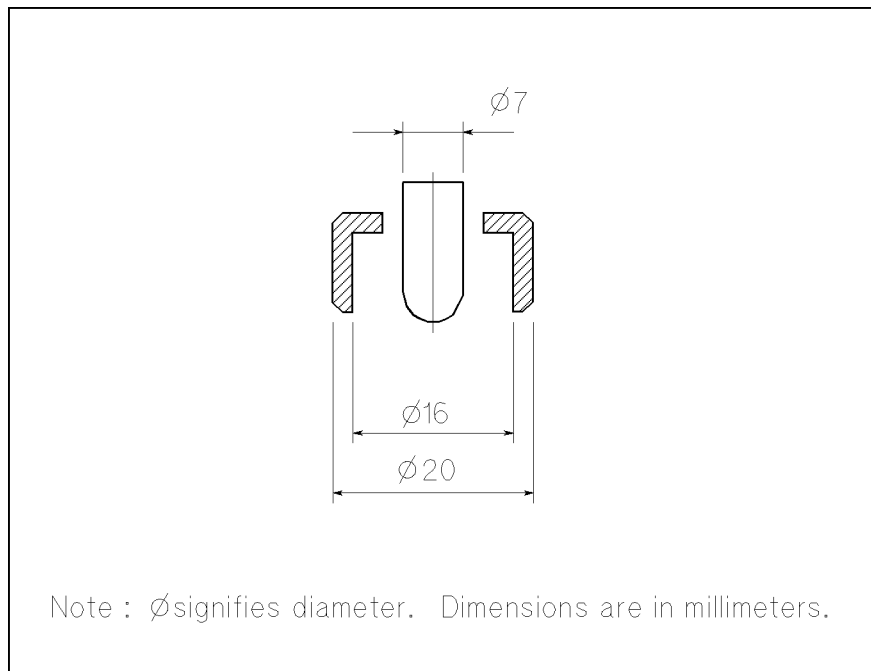

A6002004

Figure 2-7. Dimensions of Electrode-D

Unguarded Electrode

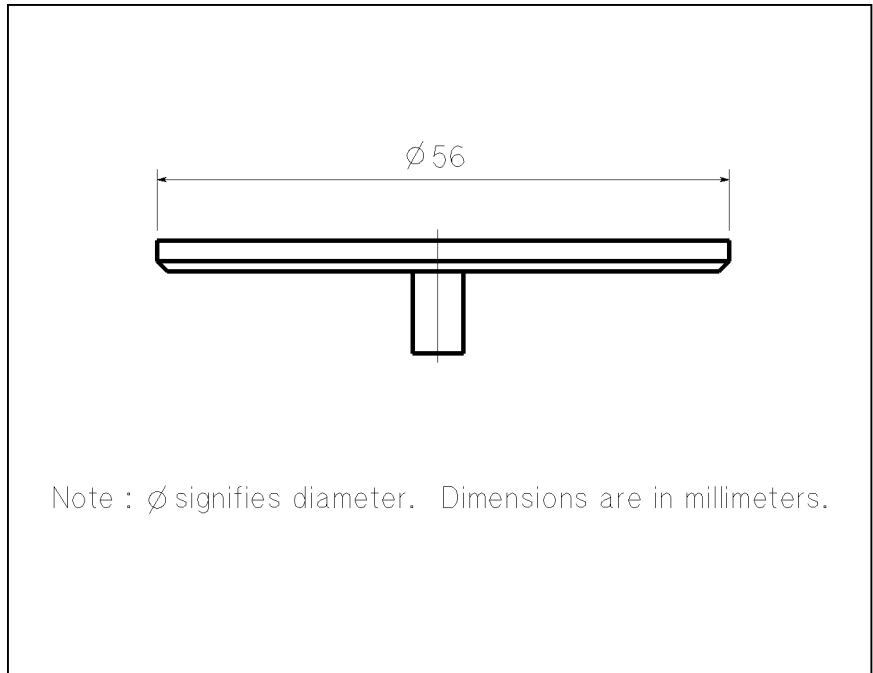

A6002005

Figure 2-8. Dimensions of Unguarded Electrode

Available Test Material Dimensions

Table 2-1. Available Test Material Dimensions

Electrode Used	Diameter	Thickness	Guarded Electrode Diameter
Electrode-A	40 to 56 mm	≤ 10 mm	38 mm
Electrode-B	10 to 56 mm	≤ 10 mm	5 mm
Electrode-C	56 mm	≤ 10 mm ^{*1}	5 to 50 mm ^{*2}
Electrode-D	20 to 56 mm	≤ 10 mm ^{*1}	5 to 14 mm ^{*2}

^{*1} Including thickness of thin film electrodes

^{*2} As a diameter of the thin film electrode

Micrometer Resolution 10 μm

Dimensions of Fixture Assembly

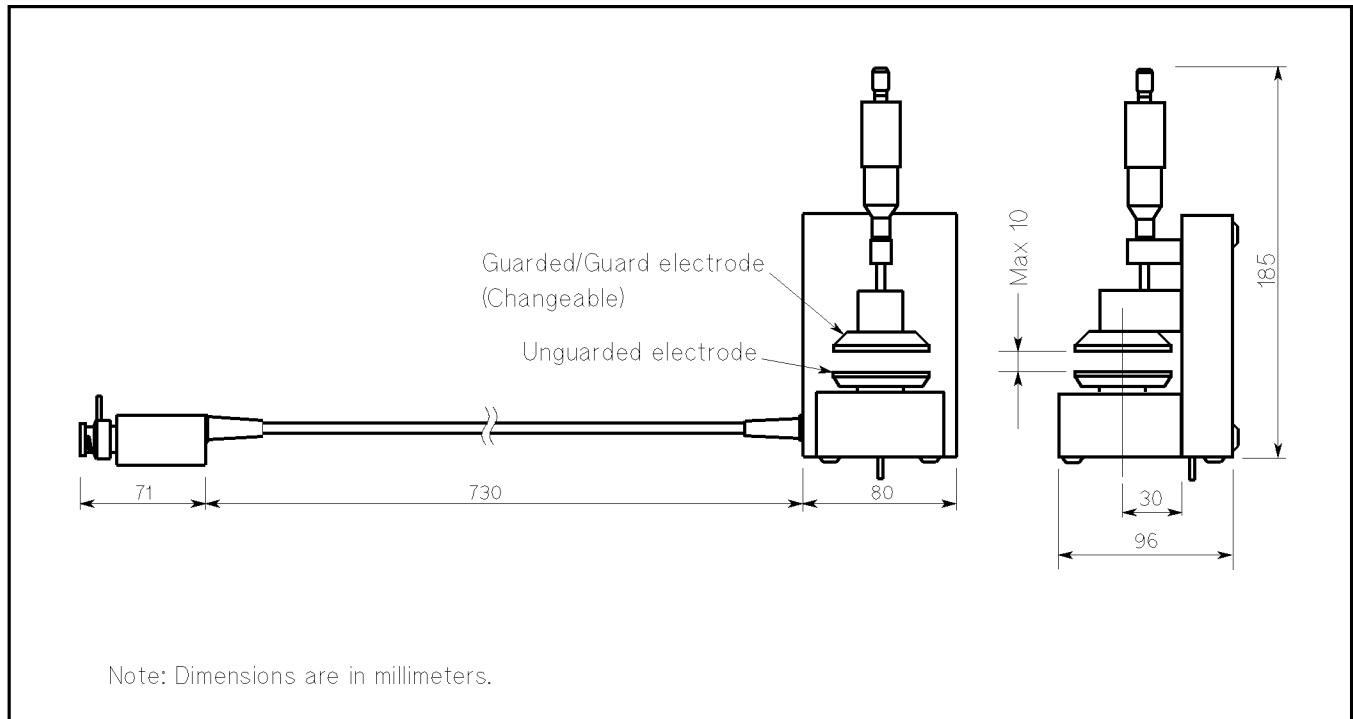

Figure 2-9. Dimensions of Test Fixture Assembly

Storage and Repacking

This section describes the environment for storing or shipping the 16451B, and how to repack the 16451B for shipment when necessary.

Environmental Requirements

The 16451B should be stored in a clean, dry environment. The following environmental limitations apply for both storage and shipment.

Temperature: -40°C to 70°C
Humidity: ≤95% RH (at 40°C)

To prevent condensation from taking place on the inside of the 16451B, protect the fixture against temperature extremes.

Original Packaging

Containers and packing materials identical to those used in factory packaging are available through your closest Agilent Technologies sales office. If the instrument is being returned to Agilent Technologies for servicing, attach a tag indicating the service required, the return address, the model number, and the full serial number. Mark the container *FRAGILE* to help ensure careful handling. In any correspondence, refer to the fixture by model number and its full serial number.

Other Packaging

The following general instructions should be used when repacking with commercially available materials:

1. Wrap the 16451B in heavy paper or plastic. When shipping to a Agilent Technologies sales office or service center, attach a tag indicating the service required, return address, model number, and the full serial number.
2. Use a strong shipping container. A double-walled carton made of at least 350 pound test material is the minimum adequate.
3. Use enough shock absorbing material (3 to 4 inch layer) around all sides of the 16451B to provide a firm cushion and to prevent movement inside the container. Use cardboard to protect the front panel.
4. Securely seal the shipping container.
5. Mark the shipping container *FRAGILE* to help ensure careful handling.
6. In any correspondence, refer to the 16451B by model number and its full serial number.

Operation

Introduction

This chapter describes the product overview, basic theory of measuring dielectric constant using the 16451B, methods for measuring dielectric constant step by step, details of measurement procedure basic measurement procedure summarized and typical measurement procedures with measurement results using the 4194A and 4284A. The last part of this chapter describes measurement error factors.

Warning



DO NOT apply more than $\pm 42 V_{\text{peak}}$ total test signal level and dc bias voltage to the unknown terminals. An electrical shock hazard will exist during operation when the DC bias voltage is greater than 42 V DC.

16451B Overview

The 16451B is a test fixture for measuring disc and film dielectric materials when connected to Agilent's LCR meters or impedance analyzers, and is usable up to 15 MHz. The 16451B provides the fixture assembly, four interchangeable Guarded/Guard electrodes and accessories. Figure 3-1 shows the 16451B fixture assembly and Figure 3-2 shows the accessories furnished with the 16451B.

Fixture Assembly

The 16451B fixture assembly is equipped with a 4-terminal pair cable assembly, Guarded/Guard electrodes, and a micrometer to set the distance between the electrodes. The cable assembly can be connected directly to the 4-terminal pair measurement terminals of the instrument, and the configuration is changed to a 3-terminal at the Guarded/Guard electrodes. Figure 3-1 and Table 3-1 show the configuration name of each part of the fixture assembly.

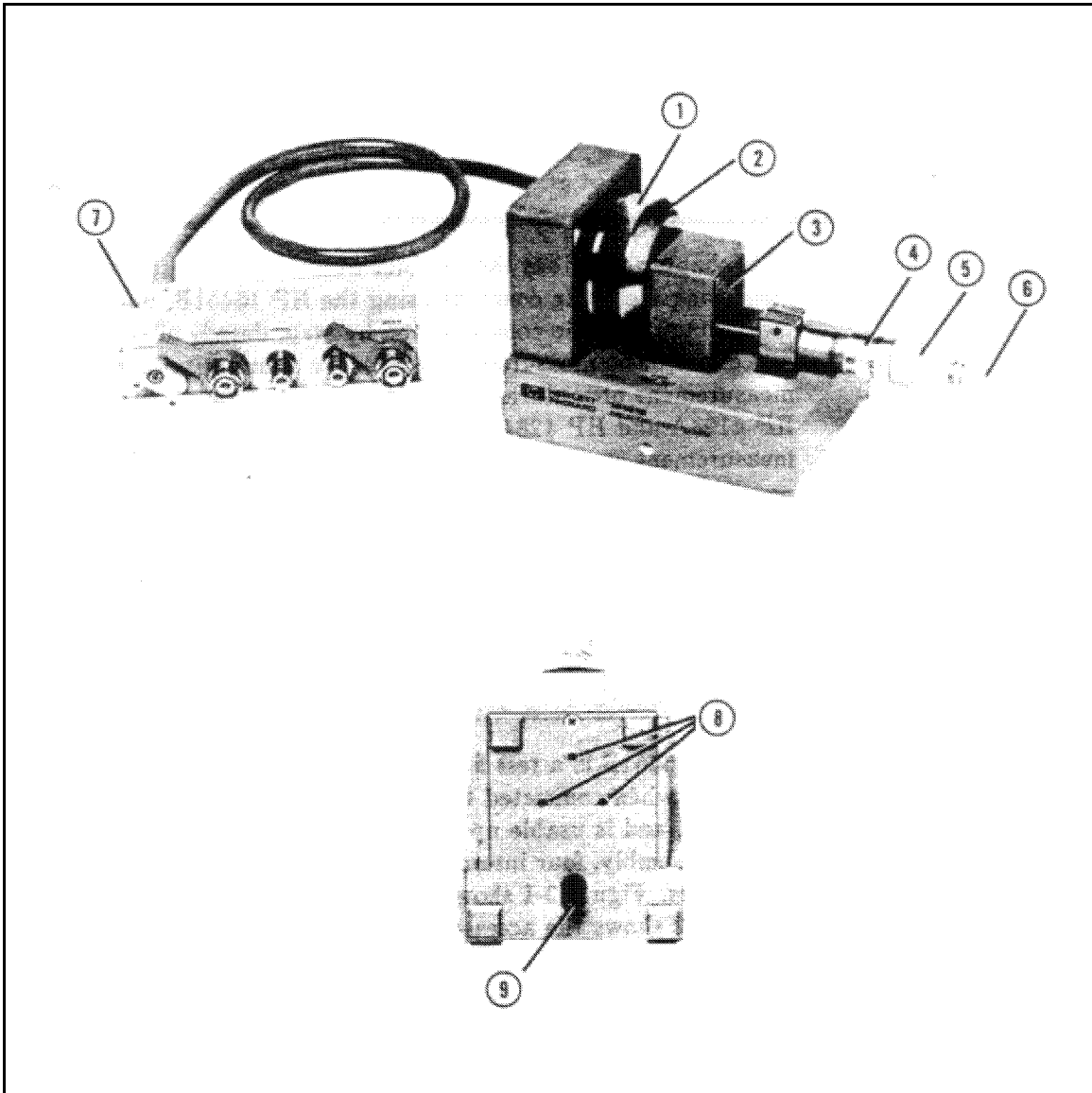

Figure 3-1. Fixture Assembly

The name and description of the fixture assembly shown in Figure 3-1 are listed in the following table (Table 3-1).

Table 3-1. Name of Fixture Assembly

No.	Name of Part	Description
(1)	Unguarded electrode	This electrode is connected to the Hc(High current) and Hp(High potential) terminal of the instrument.
(2)	Guarded/Guard electrode	This electrode is combined by a Guarded electrode and a Guard electrode. The guarded electrode is connected to the Lc(Low current) and Lp(Low potential) terminals of the instrument. The guard electrode is connected to the guard terminal. This electrode is interchangeable and is movable using the knobs on the micrometer.
(3)	Guarded/Guard electrode attachment screw	This screw secures the Guarded/Guard electrode.
(4)	Micrometer	The micrometer is used to adjust the distance between electrodes. Do not use this to measure thickness the of test material.
(5)	Adjustment knob (large knob)	This knob should be used for coarse adjustment of electrode distance. Do not use the large knob to bring the Guarded/Guard electrode into contact with the Unguarded electrode or test material.
(6)	Ratchet knob (small knob)	This knob is used to bring the Guarded/Guard electrode into contact with the Unguarded electrode or material.
(7)	Cable assembly	This cable assembly connects the 16451B to 4-terminal pair UNKNOWN terminals on the instrument's front panel.
(8)	Unguarded electrode adjustment screws	These screws are used to make the Unguarded electrode parallel with the Guarded/Guard electrode.
(9)	Guarded/Guard electrode pressure adjuster	When the 16451B is placed so that the surface of electrodes is horizontal, this adjuster pushes the Guarded/Guard electrode to adjust its pressure on the Unguarded electrode to be the same as when the 16451B is placed so that the surface of electrodes is perpendicular.

Caution



DO NOT use the large knob to bring the Guarded/Guard electrode into contact with the Unguarded electrode or test material, doing so will damage the micrometer or the surface of the electrodes. You must use the small knob when you bring the electrode into contact with another electrode or test material. It has a built in clutch which will slip at a specified torque.

Furnished Accessories

The 16451B provides some accessories, such as 4 types of changeable electrodes and their covers, an attachment for error correction, Hex key, and Carrying case. Figure 3-2 and Table 3-2 show the furnished accessories.

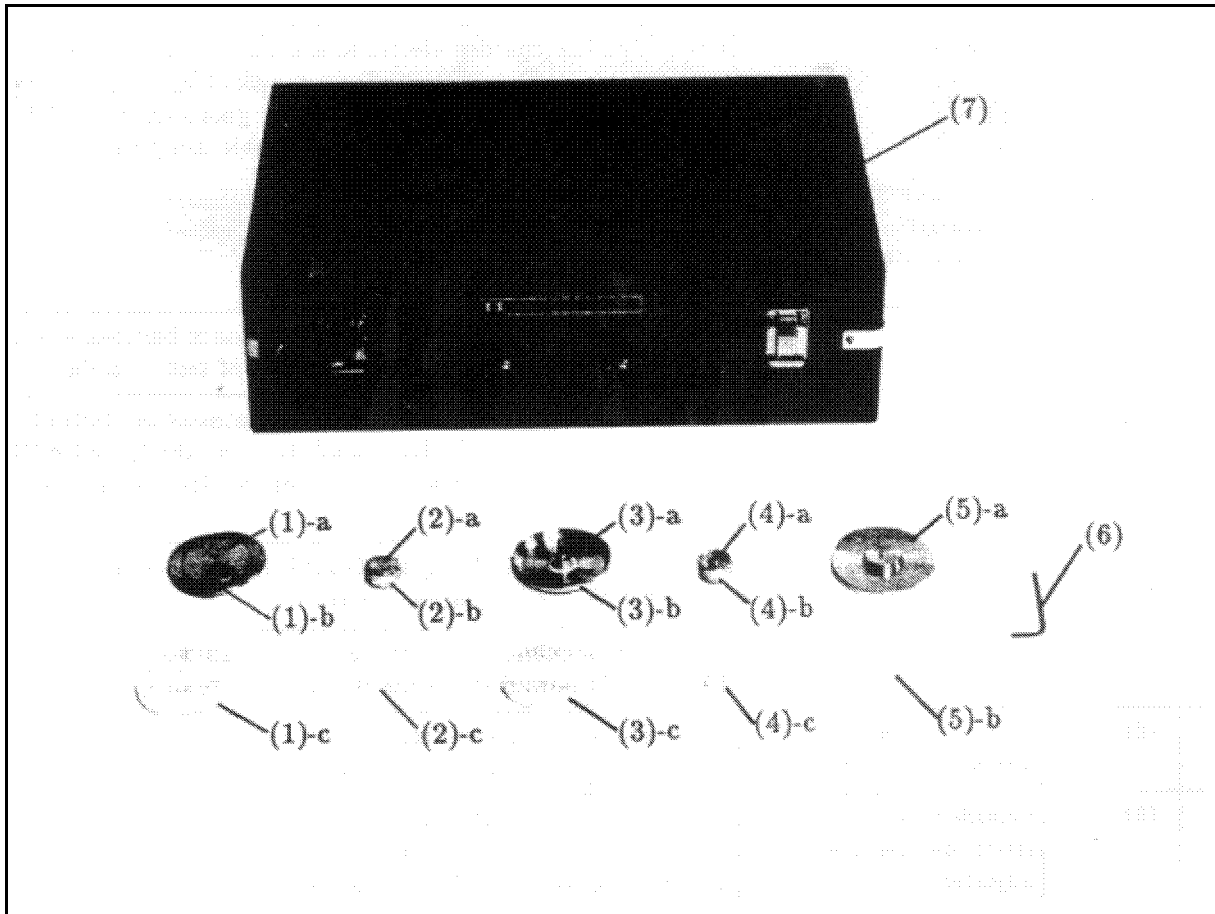

Figure 3-2. Furnished Accessories

Table 3-2. Name of Furnished Accessories

No.	Name of accessory	Description
(1)	Electrode-A (38 mm Guarded/Guard electrode)	This electrode is used to measure a material without thin film electrode and consists of a Guarded electrode (①-a) and a Guard electrode (①-b). The diameter of guarded electrode is 38 mm. The electrode is provided with a cover (①-c) to protect its surface.
(2)	Electrode-B (5 mm Guarded/Guard electrode)	This electrode is used to measure a material without thin film electrodes and consists of a Guarded electrode (②-a) and a Guard electrode (②-b). The diameter of guarded electrode is 5 mm. The electrode is provided with a cover (②-c) to protect its surface.
(3)	Electrode-C (Electrode for large thin film electrodes)	This electrode is used to measure test materials which already have thin film electrodes applied and consists of a Guarded electrode (③-a) and a Guard electrode (③-b). The electrode is provided with a cover (③-c) to protect its surface.
(4)	Electrode-D (Electrode for small thin film electrodes)	This electrode is used to measure test materials which already have thin film electrodes applied and consists of a Guarded electrode (④-a) and a Guard electrode (④-b). The electrode is provided with a cover (④-c) to protect its surface.
(5)	Attachment for error correction	This is an attachment used for OPEN and SHORT corrections. ⑤-a shows the attachment and ⑤-b shows its cover.
(6)	Hex key	This is a hex key used to interchanging and adjust the electrodes.
(7)	Carrying case	This is a carrying case used to store and carry the fixture assembly and its accessories.

Dielectric Measurement Basic

This section contains information of the basic theory of dielectric measurements and its measurement methods.

Basic theory

This section describes the basic theory of dielectric constant measurement. The dielectric constant, a fundamental parameter of insulating or dielectric materials, is calculated from the capacitance value when the material is used as the dielectric. A practical measurement procedure is described in “Typical Measurement Procedure by the Measurement Methods”. For the dielectric constant calculation, consider a solid material which is shaped into a disc as shown in Figure 3-3.

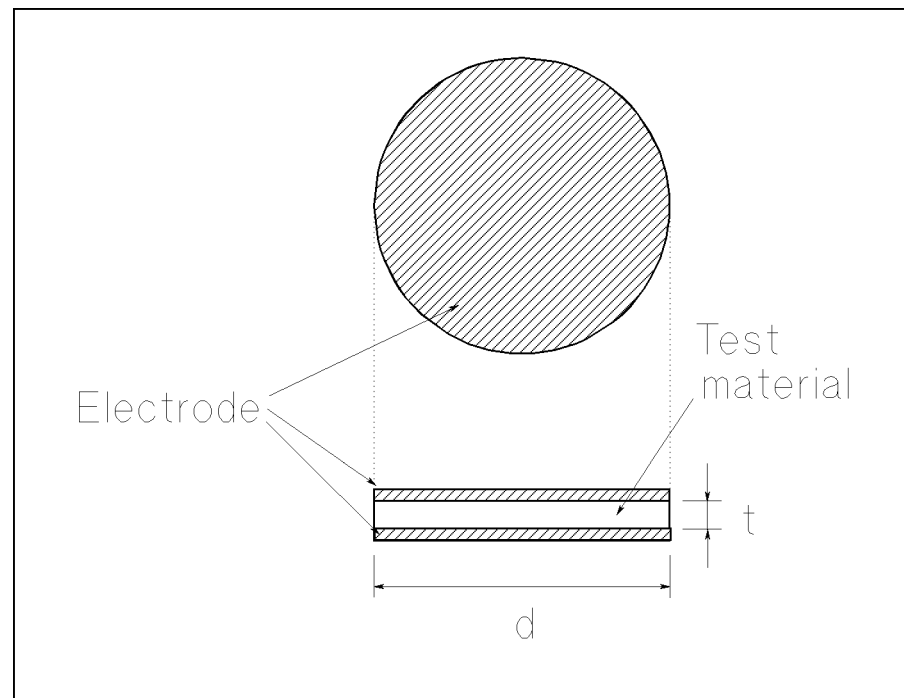

A6003001

Figure 3-3. Basic Model for Dielectric Measurement

The dielectric constant can be obtained using the following equation.

$$\begin{aligned}\epsilon &= \epsilon_o \epsilon_r \\ &= \frac{t}{A} C_p\end{aligned}$$

Where,

- ϵ Dielectric constant (permittivity) [F/m]
- ϵ_o Space permittivity = 8.854×10^{-12} [F/m]
- ϵ_r Relative dielectric constant (Relative permittivity) of test material
- C_p Equivalent parallel capacitance value [F]
- t Thickness of test material [m]

A Area of electrode [m^2]

Thus, the relative dielectric constant (generally called the dielectric constant) of the test material, ϵ_r , can be obtained by measuring the capacitance value and calculating using the following equation.

$$\begin{aligned}\epsilon_r &= \frac{t \times C_p}{A \times \epsilon_o} \\ &= \frac{t \times C_p}{\pi \times \left(\frac{d}{2}\right)^2 \times \epsilon_o}\end{aligned}$$

Where,

d Diameter of electrode [m]

The dielectric dissipation factor (= $\tan\delta$; loss tangent) of test material, D_r can be obtained directly by measuring the dissipation factor.

If the diameter of electrode is 38 mm, the denominator of the above mentioned equation becomes simple:

$$\pi \times \left(\frac{d}{2}\right)^2 \times \epsilon_o \approx 1 \times 10^{-14}$$

Then, the equation to obtain the dielectric constant is :

$$\epsilon_r = t \times C_p \times 1 \times 10^{14}$$

Guard Electrode

The dielectric constant of the disk material shown in Figure 3-3 is calculated from the measured capacitance value, as above-mentioned. When the capacitance of the disk material is measured, there is measurement error caused by stray capacitance at the edge of the test material, as shown in the left of figure of Figure 3-4. When the guard electrode as used by the 16451B surrounds the guarded electrode as used by the 16451B, it is possible to measure the capacitance of the test material accurately, because the guard electrode can avoid the stray capacitance at the edge of the electrode as shown in Figure 3-5

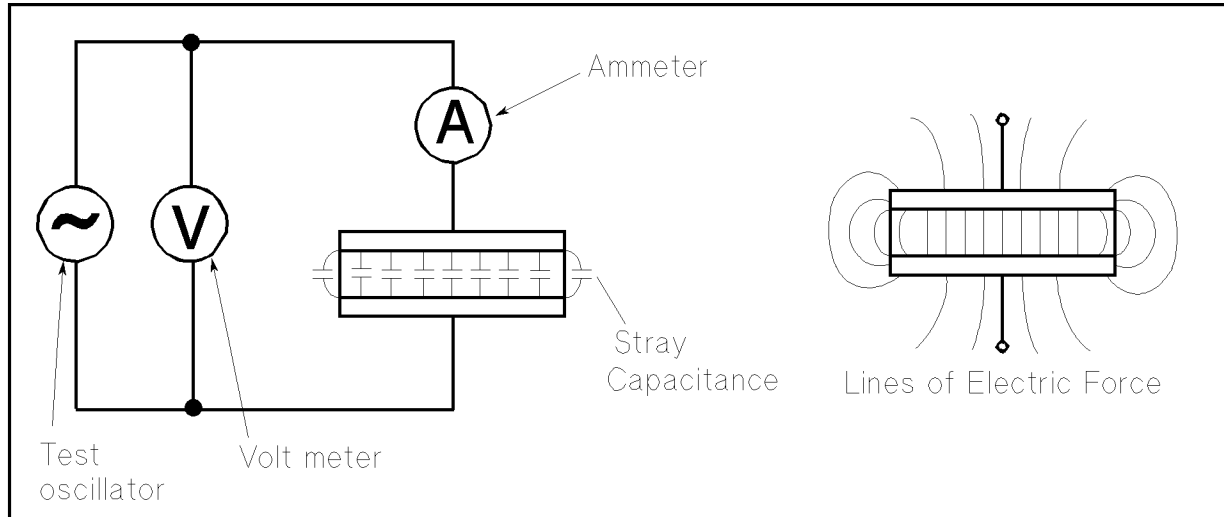

A6003026

Figure 3-4. Capacitance Measurement using Unguarded Electrode System

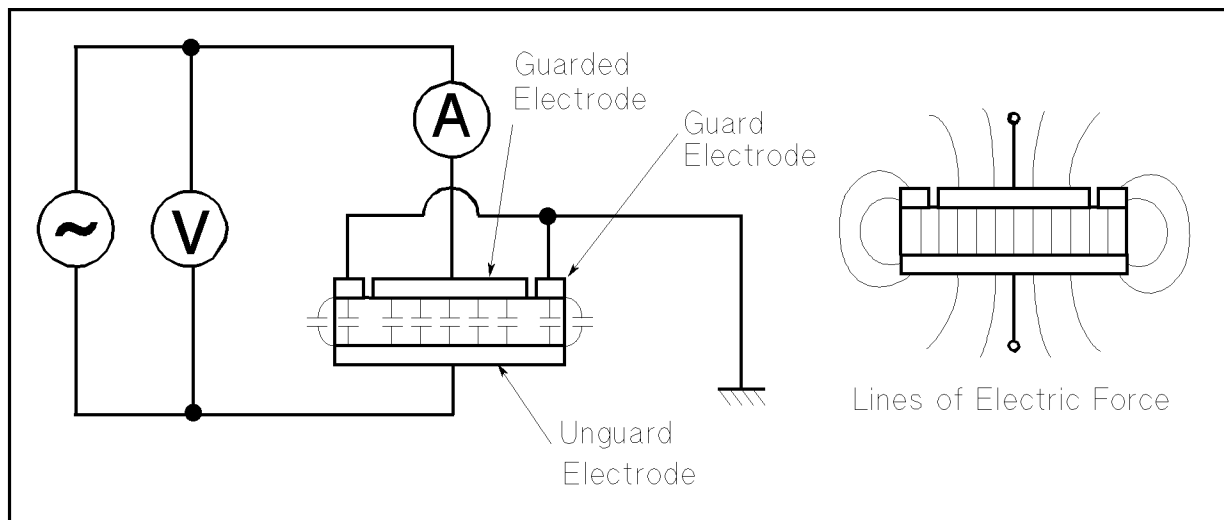

A6003027

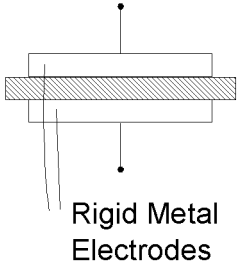
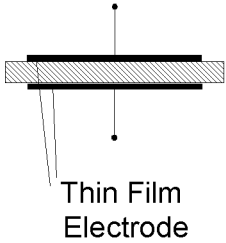
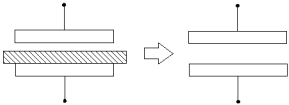

Figure 3-5. Capacitance Measurement using Guarded Electrode System

Measurement Method

This section describes three applicable measurement methods for the 16451B.

As the previous section “Dielectric Measurement Basic” explains, capacitance measurement of the test material is required when the dielectric constant of a solid test material is to be obtained. There are many kinds of methods to measure the capacitance of a solid material. Three measurement methods are applicable to the 16451B, they are the *Contacting Electrode method (Rigid Metal electrode)*, the *Contacting Electrode method (Thin Film electrode)* and the *Non-Contacting Electrode method (Air Gap method)*. You should select the suitable measurement method and the suitable electrode for your test material in order to measure it accurately.

Figure 3-6 shows a summary of three applicable measurement methods and the sections that follow describe them in more detail.

Measurement Method	Contacting Electrode Method (used with Rigid Metal Electrode)	Contacting Electrode Method (used with Thin Film Electrode)	Non-contacting Electrode Method (Air Gap Method)
Electrode* Structure	 Rigid Metal Electrodes	 Thin Film Electrode	
Operation	Simple  Complex		
Applicable Test Material	<ul style="list-style-type: none"> ○ Thick material ○ Smooth material 	Materials on which thin film electrode can be applied without changing its characteristics	<ul style="list-style-type: none"> ○ Including contacting Method's applicable test Materials ○ Highly compressible material ○ Soft material
Electrodes of 16451B	Electrode-A Electrode-B	Electrode-C Electrode-D	Electrode-A Electrode-B

A6003035

* Guard electrodes are omitted

Figure 3-6. Summary of Measurement Methods

Contacting Electrode Method (used with Rigid Metal Electrode)

This method uses Rigid electrodes which make contact directly the surface of the test material. This method is applicable for thick, smooth or slightly compressible materials. The merits and demerits of this method are as follows:

■ Merits

- Procedure to measure capacitance is simple
- It is not necessary to apply thin film electrodes
- Equations to obtain dielectric constant are simple

■ Demerits

- Air film (error caused by air gap between electrodes and surface of the test material) causes error.

Principle

Figure 3-7 shows the schematic electrode structure for this method.

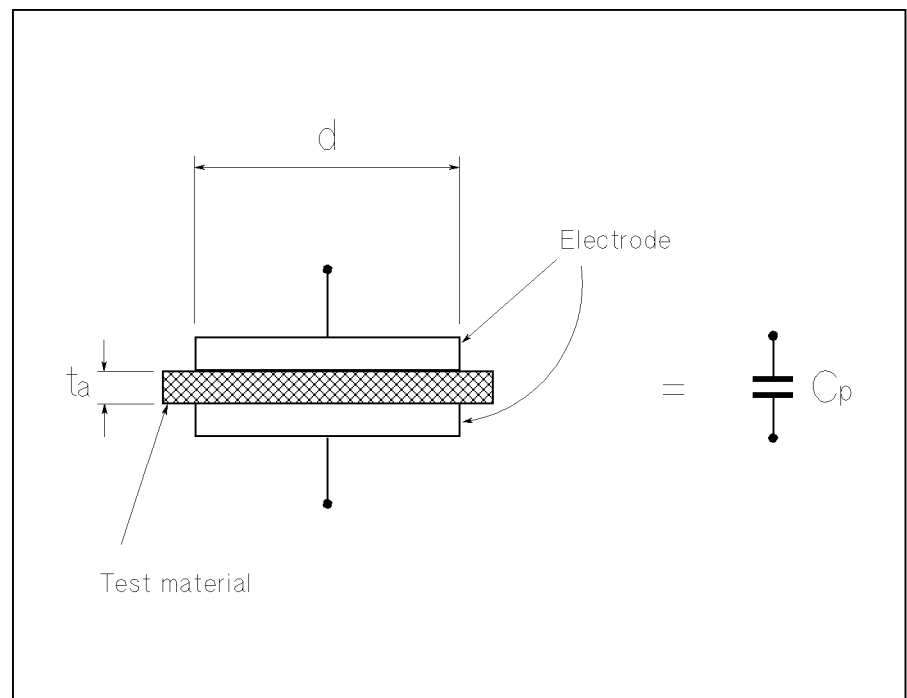

A6003022

Figure 3-7. Contacting Electrode Method (Rigid Metal Electrode)

Dielectric constant and dissipation factor of a test material can be obtained using the following equations.

Parameters Needed:

C_p	Equivalent parallel capacitance [F]
D	Dissipation factor
t_a	Average thickness of test material [m]
A	Area of Guarded electrode [m ²]
d	Diameter of Guarded electrode [m] (38×10^{-3} [m] or 5×10^{-3} [m])
ϵ_o	$= 8.854 \times 10^{-12}$ [F/m]

Equations:

$$\begin{aligned}\epsilon_r &= \frac{t_a \times C_p}{A \times \epsilon_o} \\ &= \frac{t_a \times C_p}{\pi \times \left(\frac{d}{2}\right)^2 \times \epsilon_o}\end{aligned}$$

$$D_t = D$$

Where,

ϵ_r	Dielectric constant of test material
D_t	Dissipation factor of test material

Electrodes of the 16451B

The 16451B provides two applicable electrodes, Electrode-A (38 mm electrode) and Electrode-B (5 mm electrode), for the Contacting Electrode method (Rigid Electrode method) to match the size of test material as shown in Figure 3-8. When these electrodes are used, the diameter of test materials should be much greater than the inner diameter of the Guard electrode and smaller than or equal to 56 mm. Figure 3-9 and Figure 3-10 show the applicable size of test material for these electrodes.

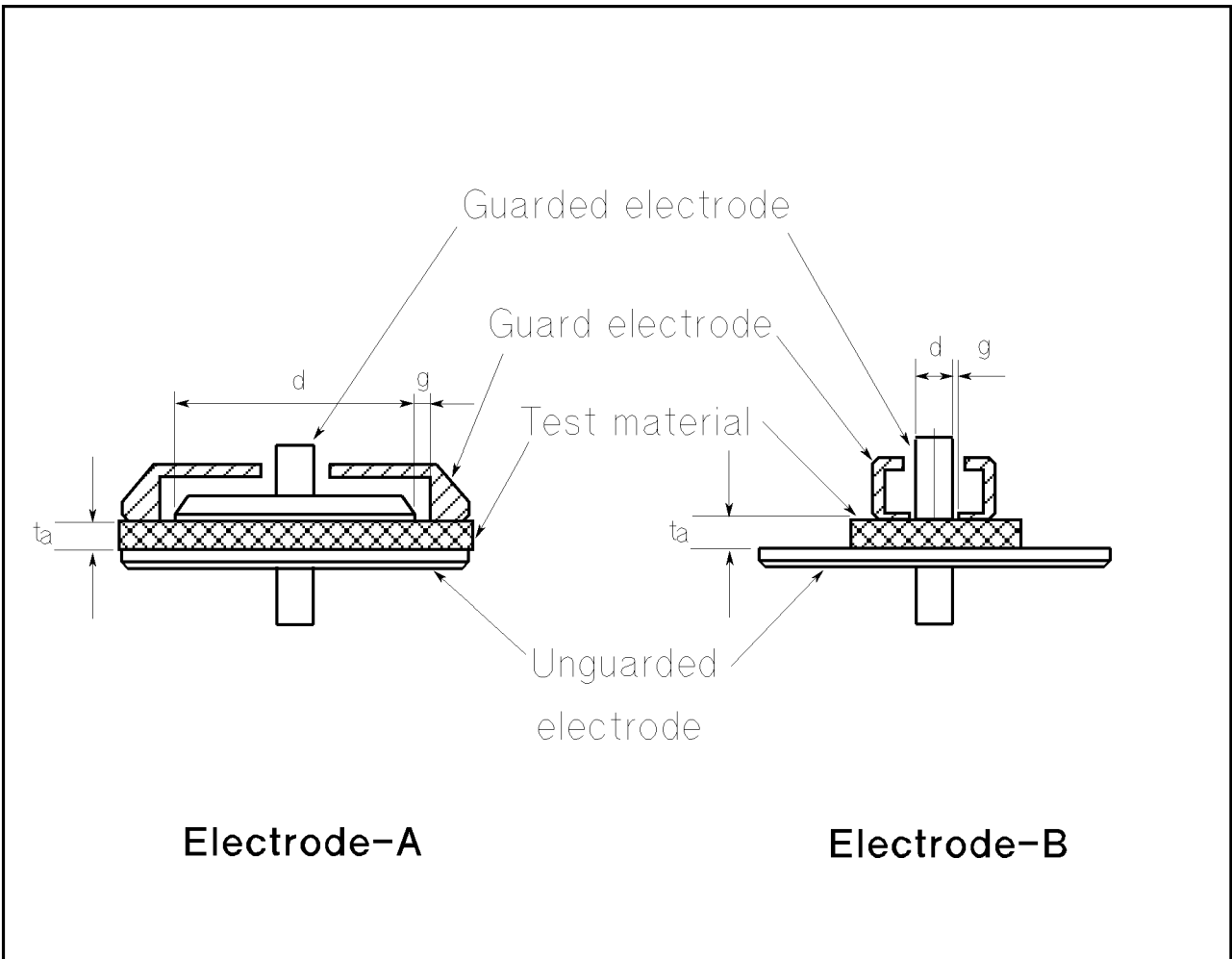

A6003031

Figure 3-8. Electrode of the 16451B for Contacting Electrode Method (Rigid Metal Electrode)

**Applicable Size of Test Material for Electrode-A
(38 mm Guarded/Guard Electrode)**

Diameter of material	greater than or equal to 40 mm and smaller than or equal to 56 mm
Thickness of material	less than or equal to 10 mm

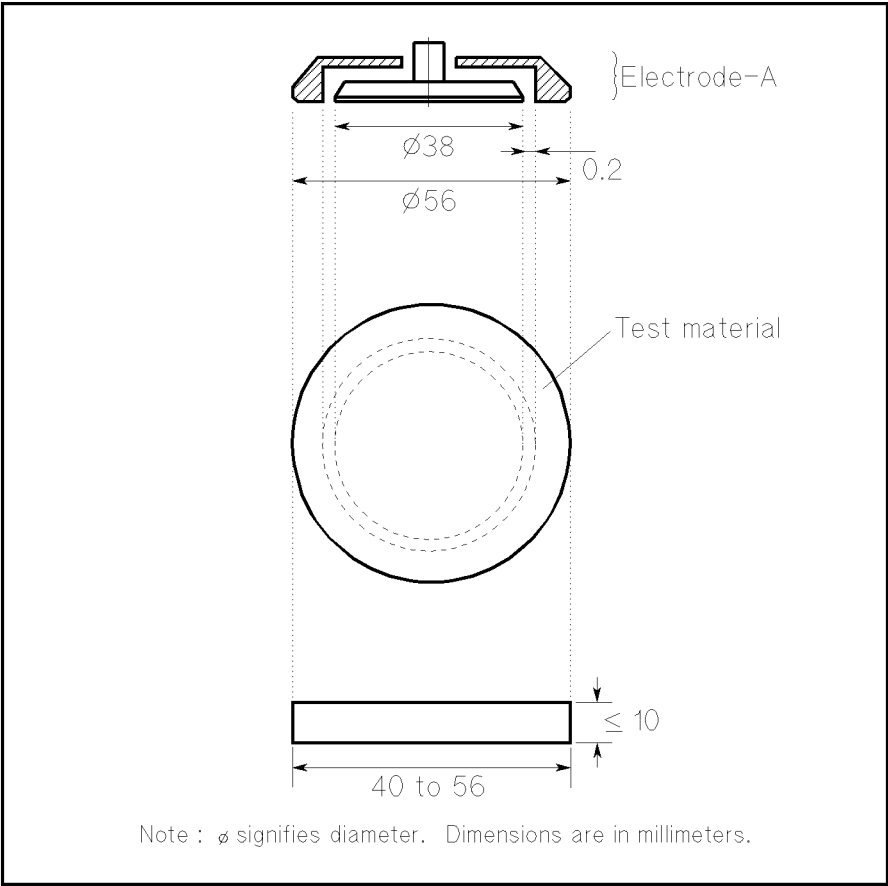

A6003004

Figure 3-9. Applicable Size of Test Material for Electrode-A

**Applicable Size of Test Material for Electrode-B
(5 mm Guarded/Guard Electrode)**

Diameter of test material	greater than or equal to 10 mm and smaller than or equal to 56 mm
Thickness of test material	less than or equal to 10 mm

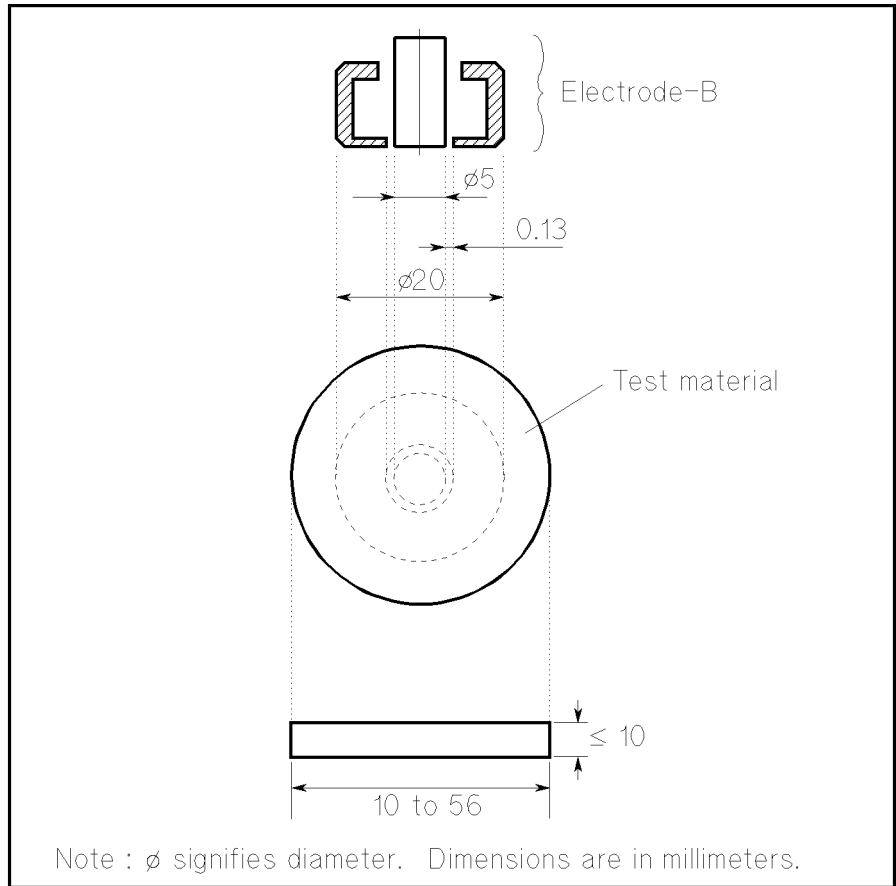

A6203005

Figure 3-10. Applicable Size of Test Material for Electrode-B

Contacting Electrode Method (used with Thin Film Electrode)

This method uses thin film electrodes applied on the test material. The thin film electrodes contact with the 16451B's electrodes. This method is applicable for materials on which the thin film electrodes can be applied without changing its characteristics. It should be noted that it is difficult to remove the thin film electrodes after the measurement. The merits and demerits of this method are as follows:

■ Merits

- Air film (error caused by air gap between the electrode and surface of the test material) causes minimum error
- Procedure to measure capacitance is simple
- Equations to obtain dielectric constant are simple

■ Demerits

- It is necessary to apply the thin film electrodes (Not applicable to materials which change their characteristics because of applying the thin film electrodes.)

Principle

Figure 3-11 shows the schematic electrode structure for this method.

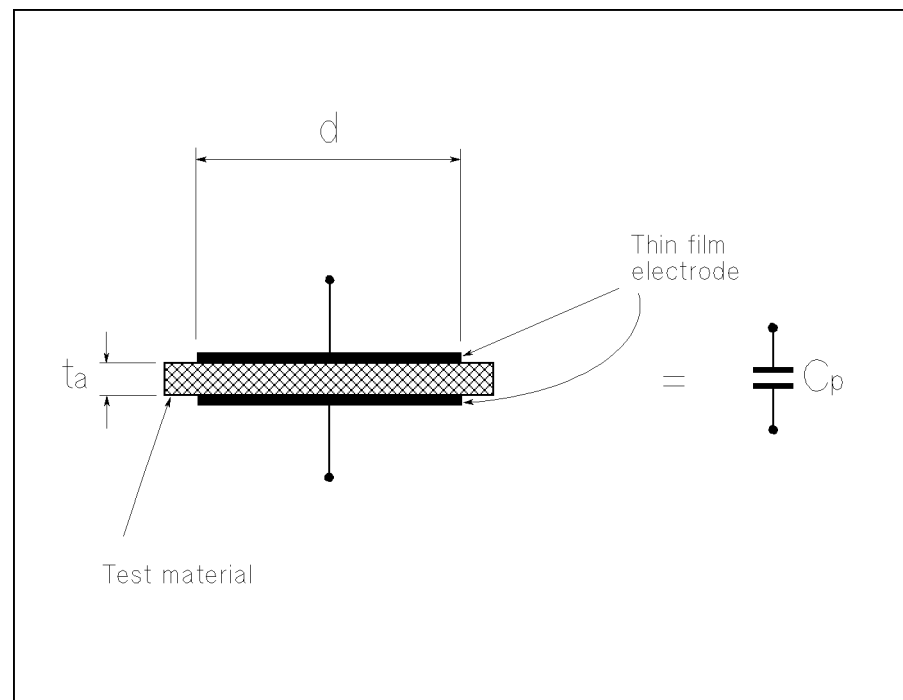

A6003023

Figure 3-11. Contacting Electrode Method (Thin Film Electrode)

Dielectric constant and dissipation factor of a test material can be obtained using the following equations.

Parameters Needed:

C_p	Equivalent parallel capacitance [F]
D	Dissipation factor
t_a	Average thickness of test material [m]
A	Area of Guarded thin film electrode [m ²]
d	Diameter of Guarded thin film electrode [m]
ϵ_o	= 8.854×10^{-12} [F/m]

Equations:

$$\begin{aligned}\epsilon_r &= \frac{t_a \times C_p}{A \times \epsilon_o} \\ &= \frac{t_a \times C_p}{\pi \times \left(\frac{d}{2}\right)^2 \times \epsilon_o}\end{aligned}$$
$$D_t = D$$

Where,

ϵ_r	Dielectric constant of test material
D_t	Dissipation factor of test material

Thin Film Electrode

When this method is used, a metallic thin film is applied on surface of the test material. For more details, refer to “Thin Film Electrode” in “Preparation of Test Material”.

Electrodes of the 16451B

The 16451B provides two applicable electrodes, Electrode-C (electrode for large thin film electrodes) and Electrode-D (electrode for small thin film electrodes), for the Contacting Electrode method (Thin Film electrode) to match the size of the test material as shown in Figure 3-12. When these electrodes are used, the diameter of the thin film guarded electrode must be smaller than the inner diameter of the guarded electrode of the 16451B and the diameter of the thin film guard electrode must be greater than the inner diameter of the guarded electrode of the 16451B. Figure 3-13 and Figure 3-14 show the applicable size of test material for these electrode.

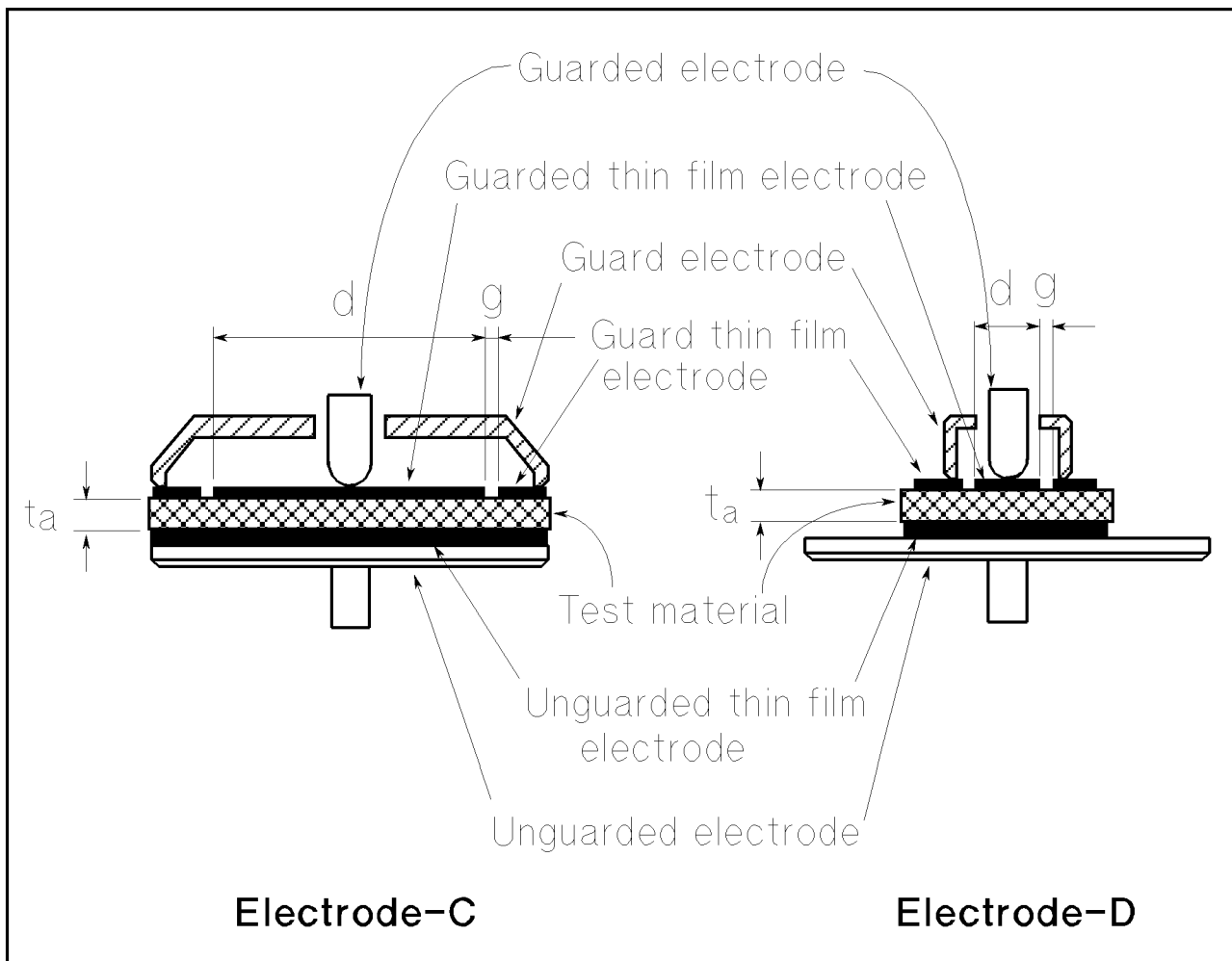

AG003032

Figure 3-12. Electrode of the 16451B for Contacting Electrode Method (Thin Film Electrode)

**Applicable Size of Test Material for Electrode-C
(Guarded/Guard Electrode for Large Thin Film Electrode)**

Diameter of test material	56 mm
Diameter of guarded thin film electrode	greater than or equal to 5 mm and less than or equal to 50 mm
Inner diameter of guard thin film electrode	less than or equal to 52 mm and greater than a diameter of guarded thin film electrode.
Gap distance between guarded thin film electrode and guard thin film electrode	as small as practical (0.5 mm is possible)
Thickness of material	less than or equal to 10 mm

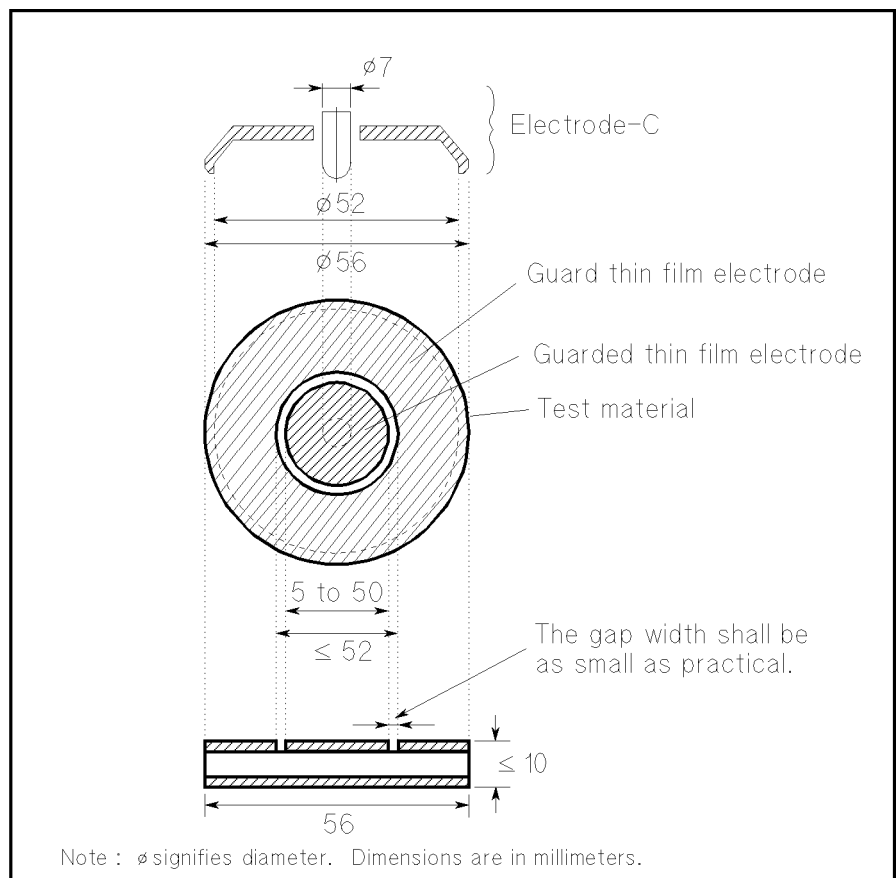

A6003006

Figure 3-13. Applicable Size of Test Material for Electrode-C

**Applicable Size of Test Material Electrode-D
(Guarded/Guard Electrode for Small Thin Film Electrodes)**

Diameter of test material	greater than or equal to 20 mm and less than equal to 56 mm
Diameter of guarded thin film electrode	greater than or equal to 5 mm and less than or equal to 14 mm
Inner diameter of guard thin film electrode	less than and equal to 16 mm and greater than a diameter of guarded thin film electrode.
Gap distance between guarded thin film electrode and guard thin film electrode	as small as practical (0.5 mm is possible)
Thickness of material	less than or equal to 10 mm

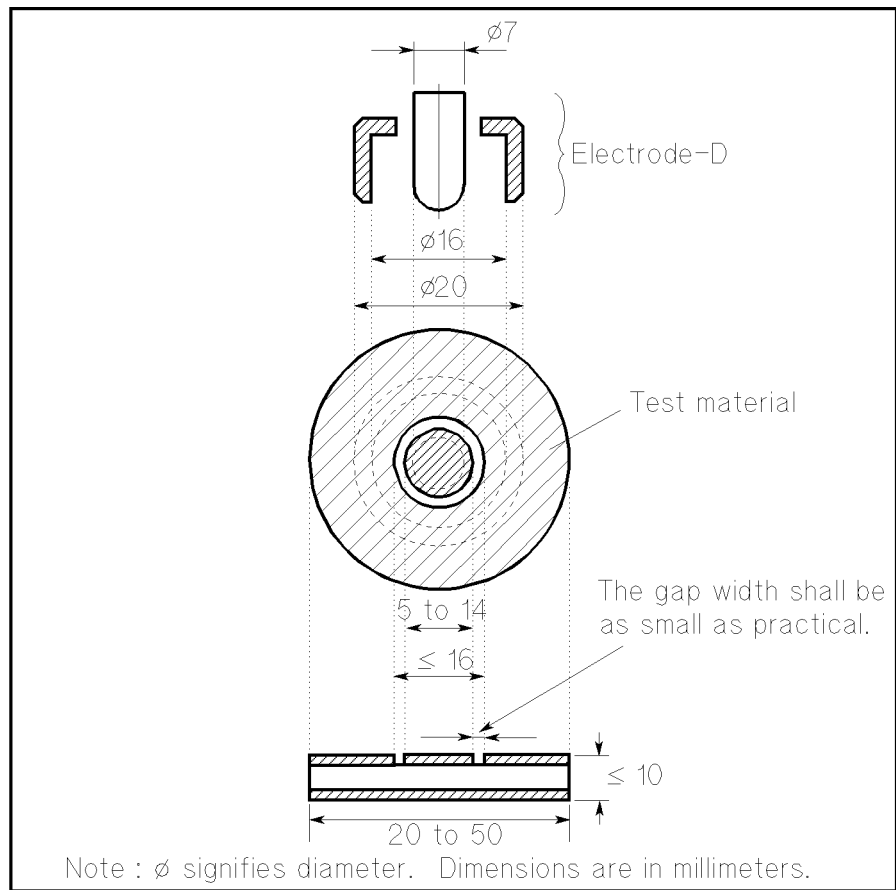

Figure 3-14. Applicable Size of Test Material for Electrode-D

Non-contacting Electrode Method (Air Gap Method)

This method accurately derives the dielectric constant from the capacitance difference between two measurements, without the test material, the other with the test material. These two measurements are made with the distance between the electrodes held constant. This method is especially applicable for film materials, highly compressible materials (such as foam rubber), or soft materials. The merits and demerits of this method are as follows:

■ Merits

- Air film (error caused by air gap between the electrode and the surface of test material) does not cause error
- It is not necessary to apply thin film electrodes

■ Demerits

- It is necessary to measure capacitance twice
- Equation to derive the dielectric constant is complex

Principle

Figure 3-15 shows the schematic electrode structure for this method.

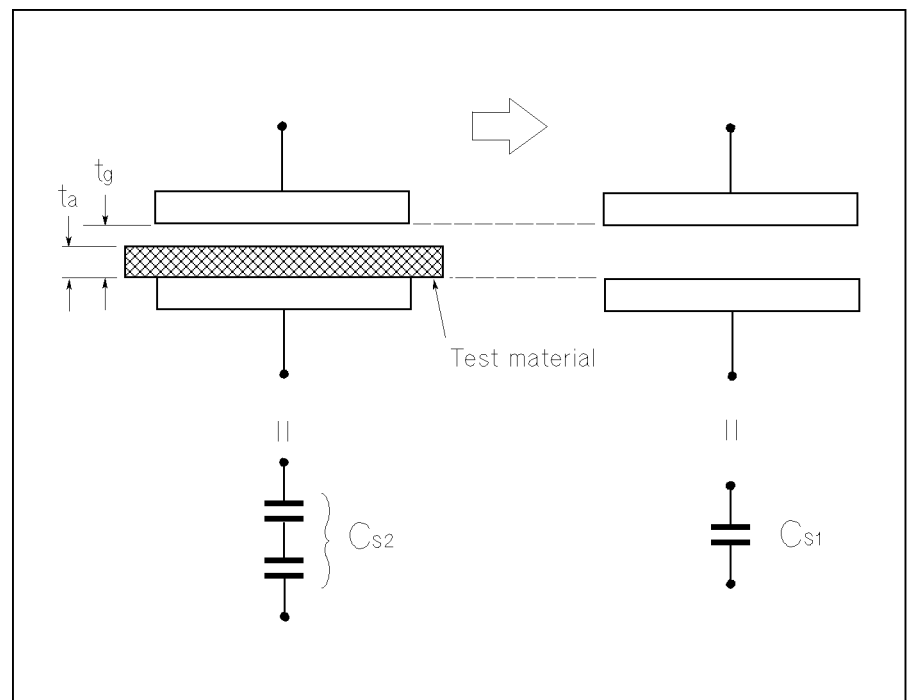

A6003024

Figure 3-15. Non-contacting method (Air Gap method)

Dielectric constant and dissipation factor of a test material can be obtained with the following equations.

Parameters Needed:

C_{s1} Series capacitance when the test material is not inserted [F]

D_1 Dissipation factor when the test material is not inserted

t_g Gap between Guarded/Guard electrode and Unguarded electrode [m]

C_{s2} Series capacitance when the test material is inserted [F]

D_2 Dissipation factor when the test material is inserted

t_a Average thickness of test material [m]

Equations:

$$\epsilon_r = \frac{1}{1 - \left(1 - \frac{C_{s1}}{C_{s2}}\right) \times \frac{t_g}{t_a}}$$

$$D_t = D_2 + \epsilon_r \times (D_2 - D_1) \times \left(\frac{t_g}{t_a} - 1\right)$$

Where,

ϵ_r Dielectric constant of test material

D_t Dissipation factor of test material

Electrodes of the 16451B

The 16451B provides two applicable electrodes, Electrode-A (38 mm electrode) and Electrode-B (5 mm electrode), for Non-contacting Electrode method (Air Gap method) to match the size of test material as shown Figure 3-16. When these electrodes are used, the diameter of test materials must be much greater than the inner diameter of the Guard electrode. Figure 3-17 and Figure 3-18 show the applicable size of test materials for these electrodes.

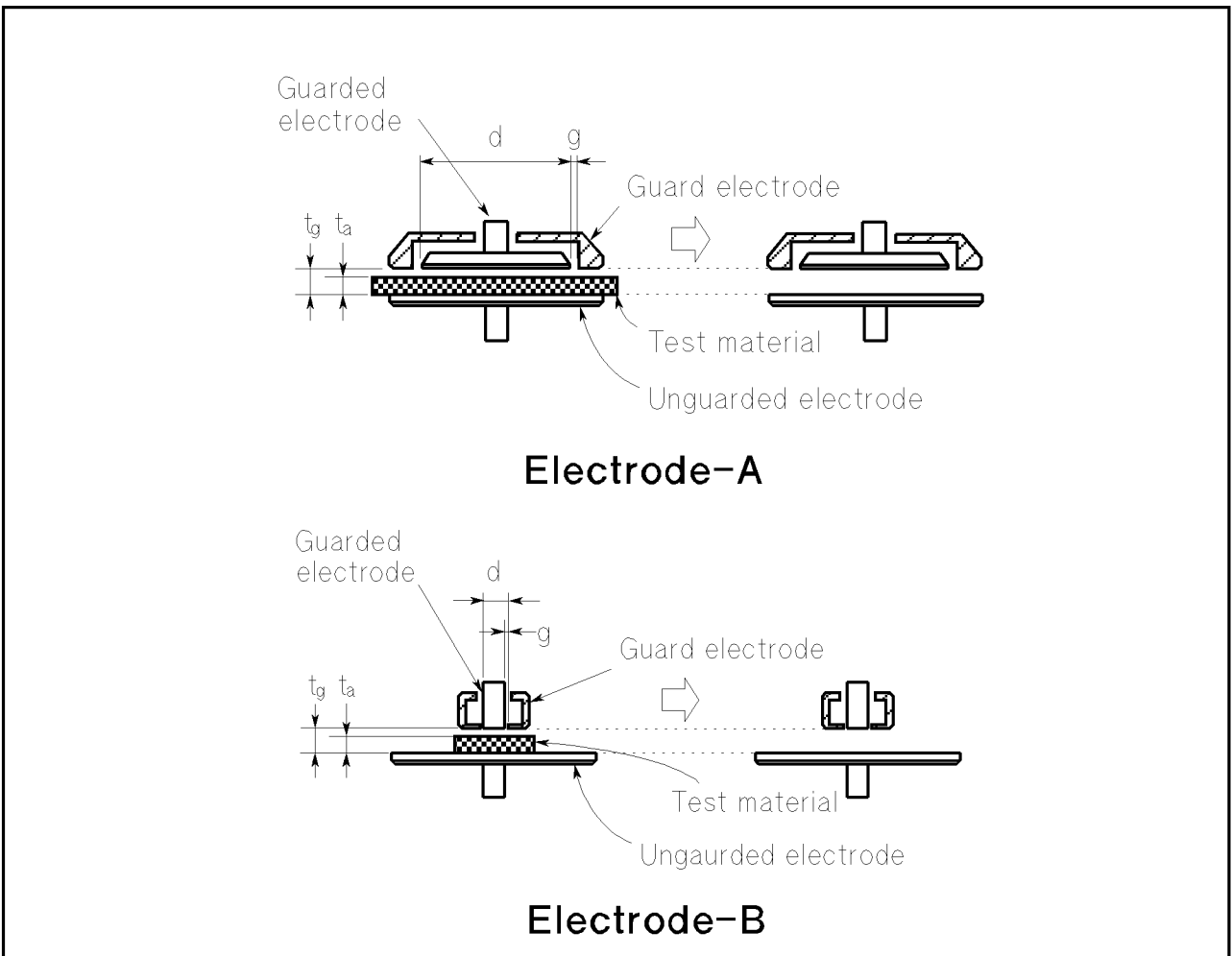
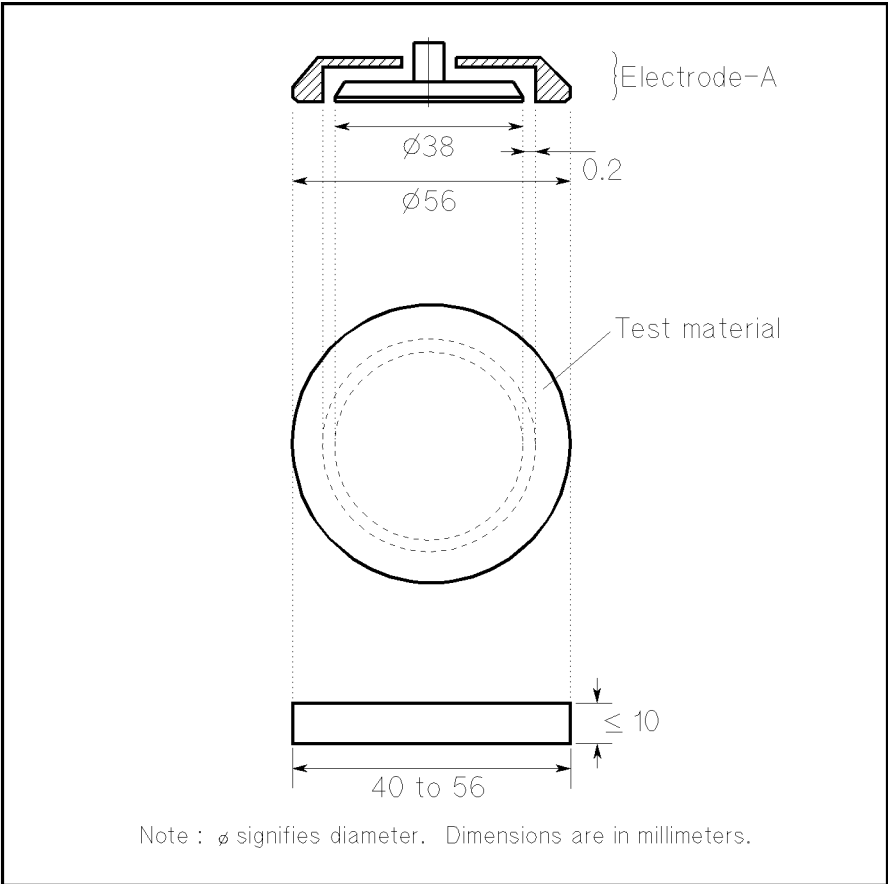

Figure 3-16. Electrode of the 16451B for Non-Contacting Electrode Method (Air Gap Method)

**Applicable Size of Test Material for Electrode-A
(38 mm Guarded/Guard Electrode)**

Diameter of material	greater than or equal to 40 mm and smaller than or equal to 56 mm
Thickness of material	less than or equal to 10 mm



A6002004

Figure 3-17. Applicable Size of Test Material for Electrode-A

Applicable Size of Test Material for Electrode-B (5 mm Guarded/Guard Electrode)

Diameter of material	greater than or equal to 10 mm and smaller than or equal to 56 mm
Thickness of material	less than or equal to 10 mm

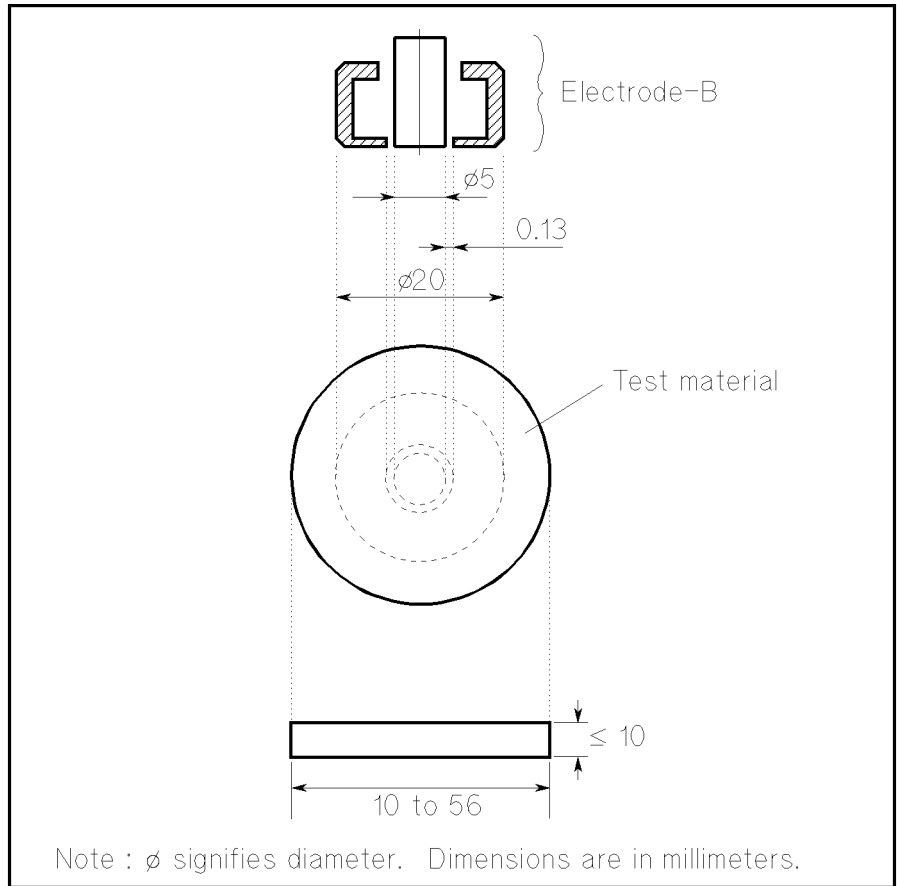

A6203005

Figure 3-18. Applicable Size of Test Material for Electrode-B

Preparation of Test Material

Dielectric constant measurement error is caused by not only capacitance measurement error, but also by the error in the test material dimensions. Therefore the test material should be accurately cut or molded so that its dimensional error will not affect the dielectric constant value. Before proceeding to the actual measurement, read the following to prepare the test material.

Shape and Size of Test Material

The applicable shape of the test material for the 16451B should be a plate or a film. The applicable size (diameter) of the test material should be greater than the inner diameter of the Guard electrode used. The 16451B can also measure test materials whose shape is not a disk, when the size of the test material is greater than the inner diameter of the Guard electrode.

Caution



Do not measure a material whose size (diameter) is much greater than Unguarded electrode, doing so will overload electrodes and damage them.

To obtain an accurate dielectric constant value, it is usually better to use larger diameter and thinner thickness of the test material so that its measured capacitance is greater. Therefore, when a low dielectric constant material is measured, it is better to use larger electrode (Electrode-A for using rigid metal electrodes and Electrode-C for using thin film electrodes). If Electrode-B or Electrode-D is used when low dielectric constant material is measured, you should change the thickness of test material so that the capacitance value is large (more than 0.1 pF). (For more detail, refer to next section “Thickness of Test Material”.)

Thickness of Test Material

A thickness of a test material is limited to the 10 mm by the range for moving the electrode of the 16451B. Because thickness is needed to obtain the dielectric constant, you must know accurately thickness of your test material. To reduce the reading error, you must average the thickness values measured at the several points in the measurement area and then use this averaged value to obtain the dielectric constant.

Note



Do not use the micrometer attached the 16451B to measure thickness of test material, because it is for setting electrode distance and is not good enough for an absolute measurement.

To obtain an accurate dielectric constant value, it is usually better to use larger diameter and thinner thickness of the test material so that its measured capacitance value is greater.

For example, when a test material whose dielectric constant is less than 10 is measured using the 16451B with an LCR meter, the value measured is only a few pF. When small capacitance is measured, measurement error increases. To reduce the error and to obtain accurate capacitance value, the capacitance value of your test material must be in the range shown in Appendix B. So you should change the thickness and diameter of your test material so that the capacitance value of your test material is in that range.

When either Electrode-B or Electrode-D are used, the measured capacitance value becomes too small because the diameter of the electrode is small. Especially, when the dielectric constant of the test material is less than 6, the capacitance value measured will be less than 0.1 pF if the thickness of test material is too thick. Such a small capacitance value is difficult to measure accurately. Therefore, when a test material whose dielectric constant is less than 6 is measured using Electrode-B or Electrode-D, you must cut or mold your test material so that the thickness (t) of the test material satisfies the following conditions (capacitance value measured becomes greater than 0.1 pF).

$$\epsilon_o \times \epsilon_r \times \frac{\pi \times \left(\frac{d}{2}\right)^2}{t} \geq 0.1 \times 10^{-12}$$

Where,

t	Thickness of test material [m]
d	Diameter of Guarded electrode [m]
ϵ_r	Dielectric constant of test material
ϵ_o	$= 8.854 \times 10^{-12}$ [F/m]

Flatness of Test Material's Surface

The surface of the test material must be flat at all points. When the Rigid Metal electrode (Electrode-A and Electrode-B) is used, flatness of the test material is especially important. If the surface of the test material is not flat, an air film (gap between an electrode and a test material) increases and this causes measurement error. Measurement error caused by non-flatness will increase when the test material is thin. For example, if the flatness error is 10 μm , the dielectric constant measurement error will be 0.3% for a material of 1 mm thickness, but the error of capacitance measurement will be about 10% for a material of 40 μm thickness.

Thin Film Electrode

Thin film electrodes can reduce the air gap between an electrode and a test material. Therefore the air film error (error caused by air gap between an electrode and a test material) using thin film electrodes is less than one using rigid metal electrodes. There are several types of thin films, such as *Metal Foil*, *Conductive Paint*, *Fired on Silver*, *Sprayed Metal*, *Evaporated Metal*, and *Metal Spattering*. Select the suitable thin film electrode. (For more detail, refer to *ASTM Standards:D150-81*, "Standard Test Method for A-C Loss Characteristics and Permittivity (Dielectric Constant) of Solid Electrical Insulating Materials".) When attaching the thin film electrode, the gap width between the guarded thin film electrode and the guard thin film electrode should be as small as practical (0.5 mm is possible).

Connecting to the Instrument

The 16451B can be connected directly to the measurement terminals of a 4-terminal pair configuration. Set the Cable Length switch or softkey of the instrument to 1 m to compensate for the error caused by the test leads of the 16451B. The procedure for setting the cable length is different by instrument, refer to the operation manual.

Changing the Guarded/Guard Electrode

This section describes the procedure to change the electrodes of the 16451B.

When you change an electrode, be careful not to contaminate or not to make scratch on the surface of the electrode. Use lint free gloves to prevent putting fingerprints on it. Also, put the covers on both of the electrodes before removing one. The removed electrode should be stored in the carrying case. The electrode replacement procedure is as follows.

1. Turn the small knob of the micrometer ccw (counterclockwise) to move the Guarded/Guard electrode away from the Unguarded electrode.
2. Put the covers on both electrodes to protect their surface.
3. Remove the Guarded/Guard electrode by loosening the screw shown in Figure 3-19 using the furnished hex key. Put it into the carrying case and take out the electrode, which you will use, from the carrying case.

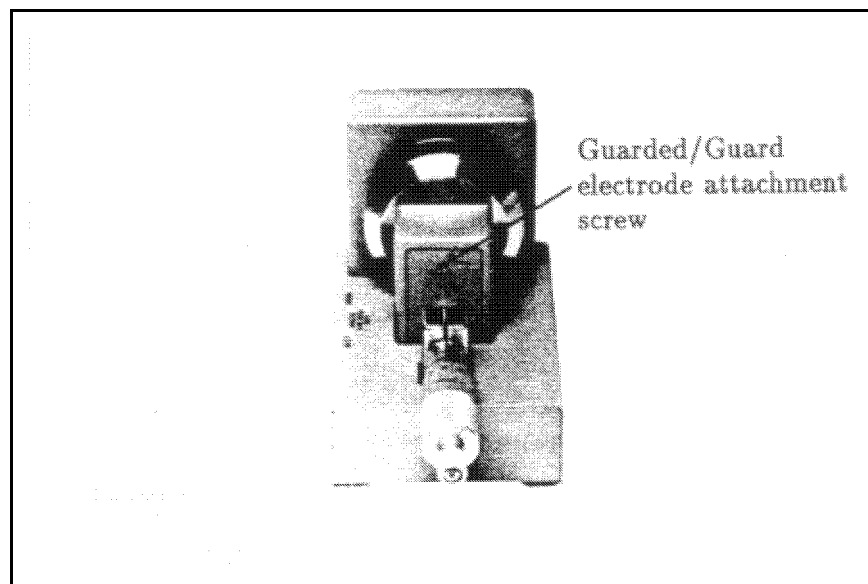

Figure 3-19.
Screw Position to Attach Guarded/Guard Electrode

4. Clean the surface of the electrodes to be used. Use a lint free cloth with alcohol. After cleaning, return the covers to protect the surface.

5. Connect the Guarded/Guard electrode and tighten the screw using a hex key.
6. Turn the small knob until it slips when the covered electrodes touch each other.

Note



After the electrode is changed, you should adjust it for parallelism. For the detailed adjustment procedure, refer to “Electrode Adjustment”.

Error Correction

The recommended measurement instruments for the 16451B listed in Table 1-2 have error correction functions to reduce residual impedance and stray admittance in the 16451B. For precise dielectric constant measurements perform the error correction. An error correction attachment, furnished with the 16451B, is necessary.

Open Correction (ZERO OPEN Offset Adjustment)

The stray admittance contained in the 16451B can be reduced by performing the following procedure.

1. Turn the small knob of the 16451B ccw to move the Guarded/Guard electrode away from the Unguarded electrode.
2. After removing the covers of both electrodes, connect the attachment with the cover to the Guarded/Guard electrode as shown in Figure 3-20. As shown in Figure 3-21, the inner electrode of the Guarded/Guard electrode is completely surrounded by the guard.

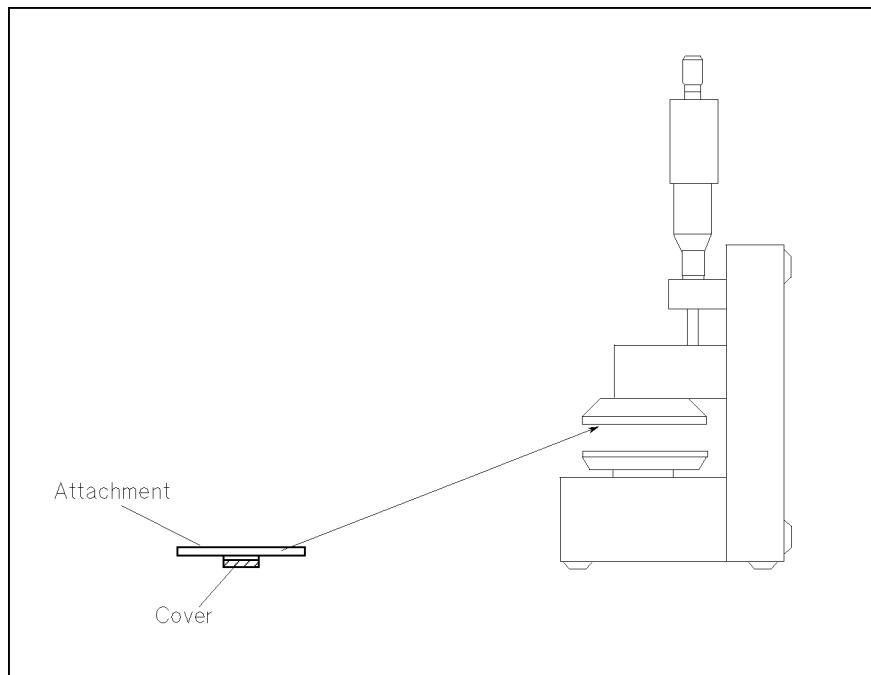

A6003014

Figure 3-20.
**Connecting the Attachment to the Guarded/Guard Electrode
for OPEN Correction**

3. Turn the small knob of the 16451B cw (clockwise) to bring the Unguarded electrode into contact with the attachment (until the clutch slips). As shown in Figure 3-21, the inner electrode of the Guarded/Guard electrode is completely surrounded by the guard.

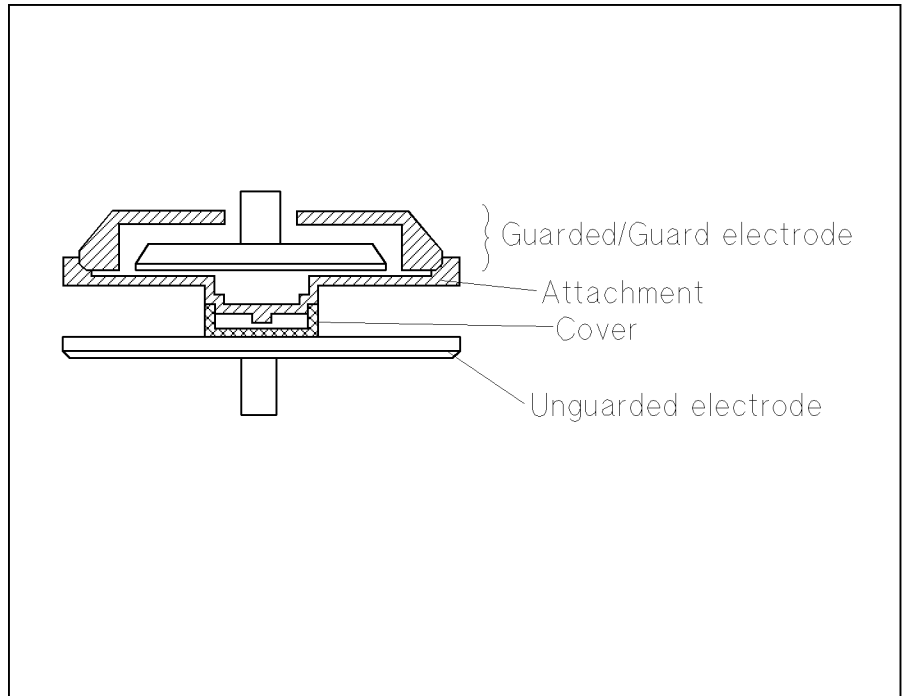

A6003013

Figure 3-21. OPEN Correction

4. Perform the OPEN correction measurement. (The procedure to perform the OPEN correction depends on the measurement instrument, for the details of this procedure, refer to Appendix C.)
5. Turn the small knob ccw to move the electrodes away from each other, and remove the attachment.

Short Correction (ZERO SHORT Offset Adjustment)

The procedure to perform SHORT correction depends on the type of the Guarded/Guard electrode used, so you should select the appropriate procedure according to the Guarded/Guard electrode you will use.

For Electrode-A and Electrode-B (Rigid Metal Electrode)

When you use Electrode-A (38 mm electrode) and Electrode-B (5 mm electrode), the residual impedance contained in the 16451B can be reduced by performing the following SHORT correction procedure.

1. Turn the small knob ccw to move the Guarded/Guard electrode away from the Unguarded electrode.
2. After removing the cover from both electrodes, also remove the cover from the attachment. Then connect the attachment to the Unguarded electrode as shown in Figure 3-22.

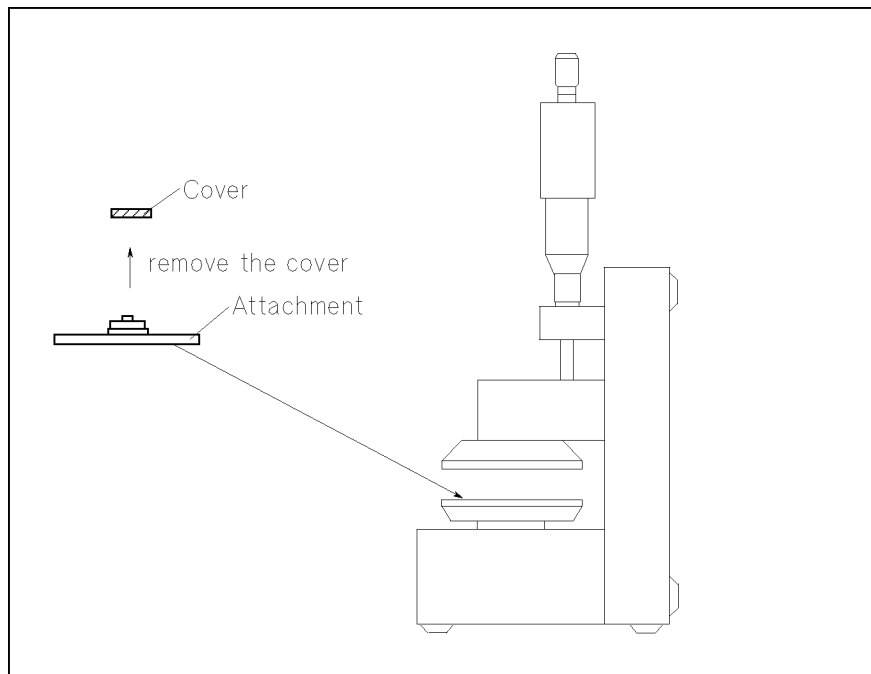

A6003016

Figure 3-22.
**Connecting the Attachment to the Unguarded Electrode for
SHORT Correction**

3. Turn the small knob cw to bring the Guarded/Guard electrode into contact with the attachment (until the clutch slips).

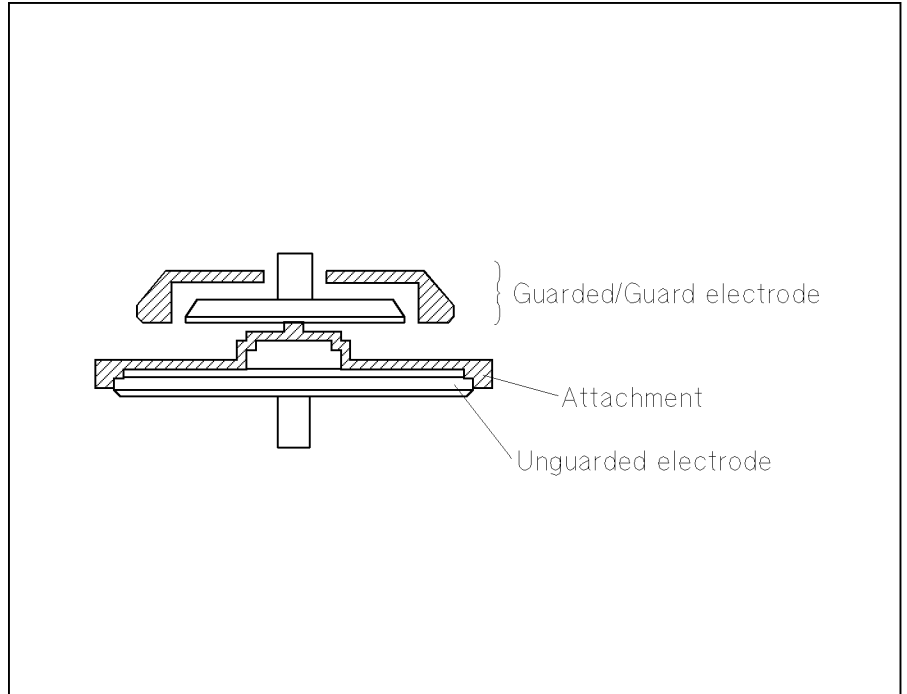

A6003015

Figure 3-23. SHORT Correction for Rigid Metal Electrode

4. Perform the SHORT correction measurement. (The procedure to perform the SHORT correction depends on the measurement instrument, for the details of this procedure, refer to Appendix C.)
5. After the measurement, turn the small knob ccw to move the electrodes away from each other and remove the attachment.

For Electrode-C and Electrode-D (Electrode for Thin Film Electrodes)

When you use Electrode-C (electrode for large thin film electrodes) and Electrode-D (electrode for small thin film electrodes), the residual impedance contained in the 16451B can be reduced by performing the following SHORT correction procedure

1. Turn the small knob ccw to move the Guarded/Guard electrode away from the Unguarded electrode, then remove the cover from both electrodes.
2. Turn the small knob cw to contact the Guarded electrode to the Unguarded electrode as shown in Figure 3-24. The Guard electrode is spring-loaded and is designed to contact earlier than the Guard electrode. But do not turn the knob until the Guard electrode contacts with the Unguarded electrode.

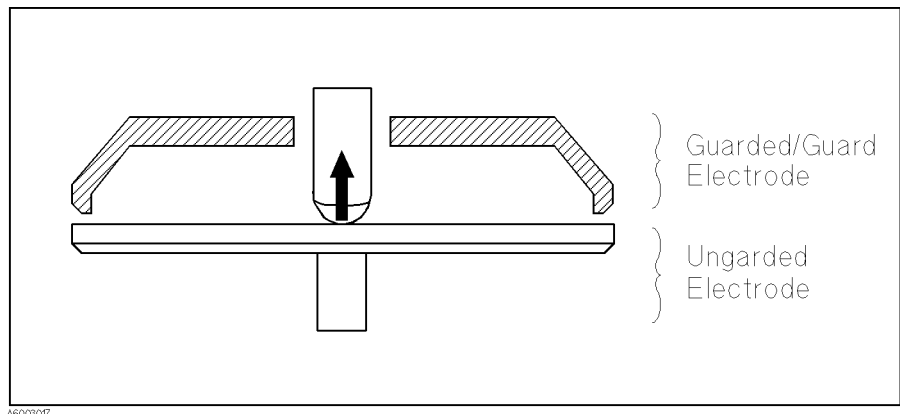

Figure 3-24. SHORT Correction for Thin Film Electrodes

Note



When the Guard electrode contacts to the Unguarded electrode before the Guarded electrode contacts to the Unguarded electrode, the electrodes deviates from the parallel position. Perform a rough adjustment to make the electrodes parallel as described in the next section "Electrode Adjustment".

3. Perform the SHORT correction measurement. (The procedure to perform the SHORT correction depends on the measurement instrument, for the details of this procedure, refer to Appendix C.)
4. After the measurement, turn the small knob ccw to move the electrodes away from each other

**LOAD Correction
(LOAD Compensation)**

If the measurement frequency exceeds 5 MHz, you must perform LOAD compensation in addition to OPEN/SHORT compensation. Use an air capacitor (adjust the distance between the electrodes to obtain the value in the following table) as the standard when measuring the LOAD compensation data. As the standard value for LOAD compensation, use the equivalent parallel capacitance value (Cp) measured at a low frequency (100 kHz). (It is assumed that the air capacitor has no dependence on frequency.)

Electrodes	Value of Load (Air Capacitor)
A	50 pF ± 0.5 pF
B	5 pF ± 0.05 pF
C and D	1.5 pF ± 0.05 pF

Actual measurement procedure for the LOAD standard is as follows: Adjust the distance between the 16451B's electrodes, measure Cp at 100 kHz, and sets it as the LOAD compensation standard value (Cp: measured value and G: 0). Then, by maintaining the distance between the electrodes, measure data as the LOAD compensation data at the frequency points where you want to measure the material. For more information, refer to the instrument's manual.

Electrode Adjustment

You should adjust the Guarded/Guard electrode until it is parallel with the Unguarded electrode for accurate measurement. You must perform this adjustment in the following cases:

- Before measurement
- After changing electrodes
- When the result of the “Check Electrode Parallelism” fails (for more details, refer to “Check Electrode Parallelism”)

Note



When you use Electrode-A or Electrode-B, and after you measure the test material (or move the electrode) several times, it is recommended to check for electrode parallelism (refer to “Check Electrode Parallelism”).

There are two adjustments, the one is a rough adjustment that visually adjust the electrode and the other is an accurate adjustment that electrically adjust the electrode using an LCR meter. (But the second one is not necessary for Electrode-C and D). Depending on the electrode you use, a different adjustment procedure should be used as follows.

- Contacting electrode method (Rigid Metal method) : Using Electrode-A, Electrode-B
 1. Perform “Rough Adjustment to Make Electrodes Parallel”
 2. Perform “Accurate Adjustment in Vertical Position”
- Contacting electrode method (Thin Film electrode) : Using Electrode-C, Electrode-D
 1. Perform “Rough Adjustment to Make Electrodes Parallel”
- Non-contacting electrode method (Air Gap method) : Using Electrode-A, Electrode-B
 1. Perform “Rough Adjustment to Make Electrodes Parallel”
 2. Perform “Accurate Adjustment in Horizontal Position”

Caution



DO NOT use the large knob to bring the Guarded/Guard electrode into contact with the Unguarded electrode or the test material, doing so may damage the micrometer or the surface of the electrodes. Use the small knob when you bring the electrode into contact with another electrode or test material. It has a built-in clutch which will slip at a specified torque.

Caution



Do not turn the Unguarded electrode adjustment screws cw when the Guarded/Guard electrode contacts Unguarded electrode. If you do so, the micrometer will be overloaded and break.

Note



You should perform the adjustment in the same environmental conditions as you will measure the test material using the 16451B, because a change of temperature causes mechanical dimensions to change. When you change temperature condition, you should perform the accurate adjustment after temperature conditions have changed,

because a change of temperature causes mechanical dimensions to change.

Rough Adjustment to Make Electrodes Parallel

This adjustment is made by checking parallelism of the electrodes visually. The adjustment requires the furnished hex key to adjust the physical position of the Unguarded electrode. Use the following procedure to perform this adjustment before the measurement and after changing the electrodes.

1. Place the 16451B so that the surface of electrodes are vertical as shown in Figure 3-25

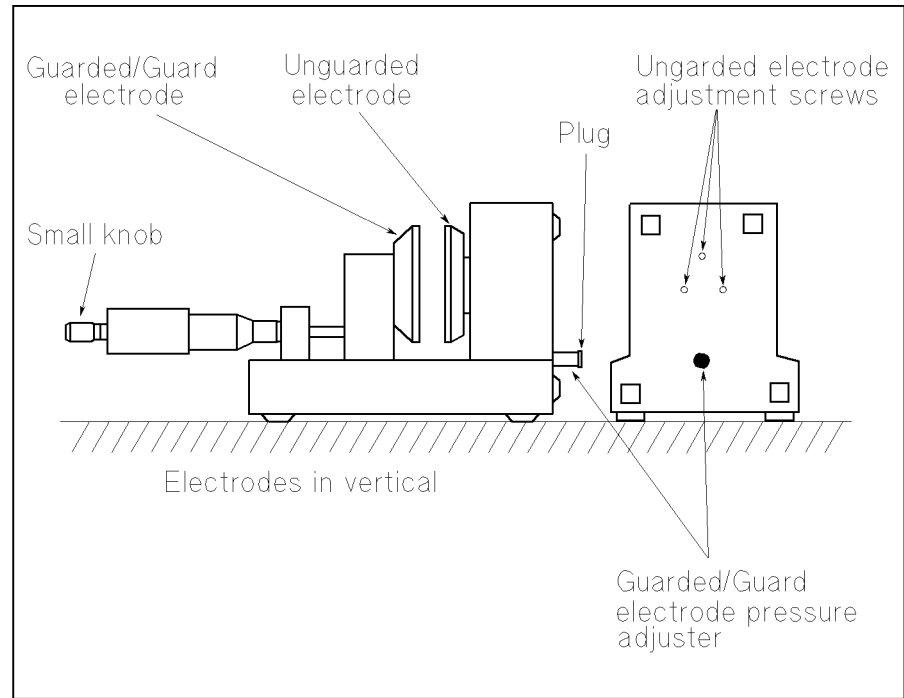

A6003021

Figure 3-25.
Vertical Position and Electrode Adjustment Screws

2. Remove the covers on both electrodes and turn the small knob of the micrometer cw to bring the Guarded/Guard electrode into contact with the Unguarded electrode until the clutch slips.
3. Check if the micrometer's scale indicates less than zero. If the clutch slips above zero, turn the small knob ccw to remove the electrodes, and then turn three Unguarded electrode adjustment screws (shown in Figure 3-25) ccw until the micrometer's scale indicates below zero when Guarded/Guard electrode contacts Unguarded electrode.
4. Check that there is no gap between the electrodes with the electrodes contacting as shown in Figure 3-26.
5. If there is a gap, turn the furthestmost adjustment screw from the gap ccw to make the electrodes parallel and go to step 1. If you can not see a gap, the rough adjustment is finished.

Perform the next step “Accurate Adjustment to Make Electrodes Parallel”, when using the Contacting electrode method (Rigid metal electrode) and Non-contacting Electrode method (Air Gap method).

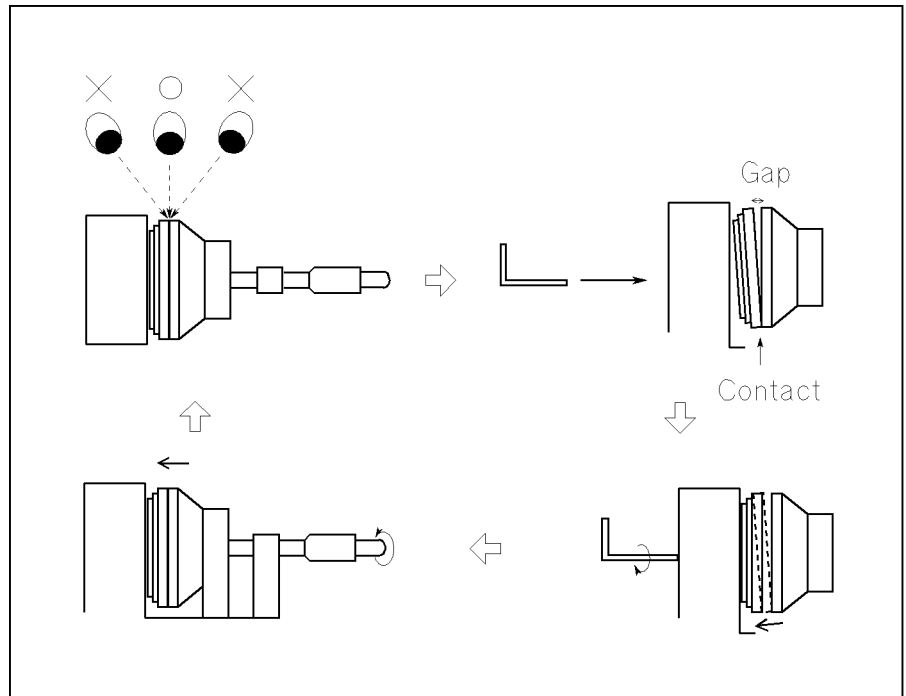

A6003009

Figure 3-26. Rough Adjustment Procedure

Accurate Adjustment to Make Electrodes Parallel

When Electrode-A and Electrode-B are used, perform the following procedure after performing the “Rough Adjustment to Make Electrodes Parallel”. When you use Electrode-C and Electrode-D (Thin Film electrodes), you do not need to perform the rough adjustment.

Accurate Adjustment in Vertical Position

When the Contacting Electrode method (Rigid Metal electrode) is used with Electrode-A and Electrode-B, perform this adjustment after the above mentioned adjustment (“Rough Adjustment to Make Electrodes Parallel”) is performed. The procedure of “Accurate Adjustment in Vertical Position” is as follows.

1. Clean the electrodes. This is necessary because the capacitance value is affected by dust. (Refer to “Changing the Guarded/Guard Electrode”.)
2. Perform OPEN/SHORT correction. (Refer to Appendix C.)
3. Connect the 16451B to an LCR meter or an impedance analyzer and select the capacitance measurement function (C_p) for Circuit mode. (Refer to “Connecting to the Instrument”.)
4. Place the 16451B so that the surfaces of electrodes are vertical as shown in Figure 3-27.

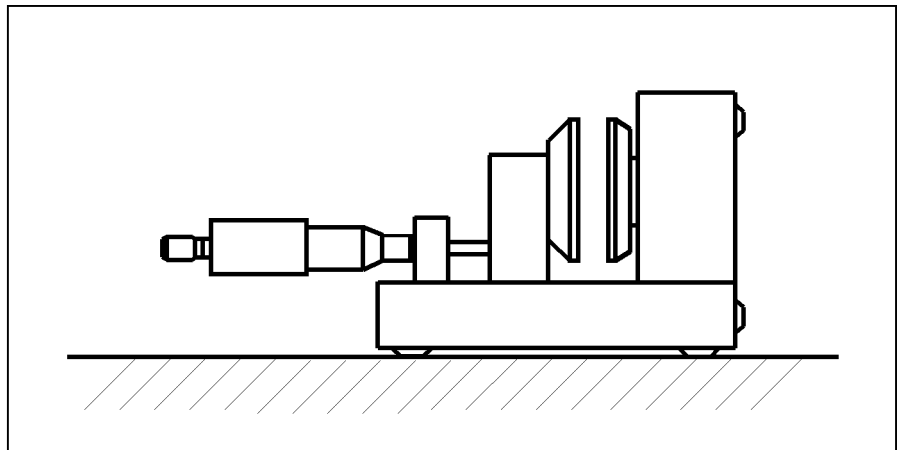

AE002010

Figure 3-27. Vertical Position

5. Turn the large knob of the micrometer ccw to make enough room between the Guarded/Guard electrode and the Unguarded electrode to remove the covers of both electrodes.
6. Turn the small knob of the micrometer cw and adjust it until the micrometer scale indicates 0.01 mm (10 μm) as shown in Figure 3-28.

If the electrodes make contact before 0.01 mm, turn the three adjustment screws ccw to move Unguarded electrode the away from the Guarded/Guard electrode until the scale can be adjusted to 0.01 mm.

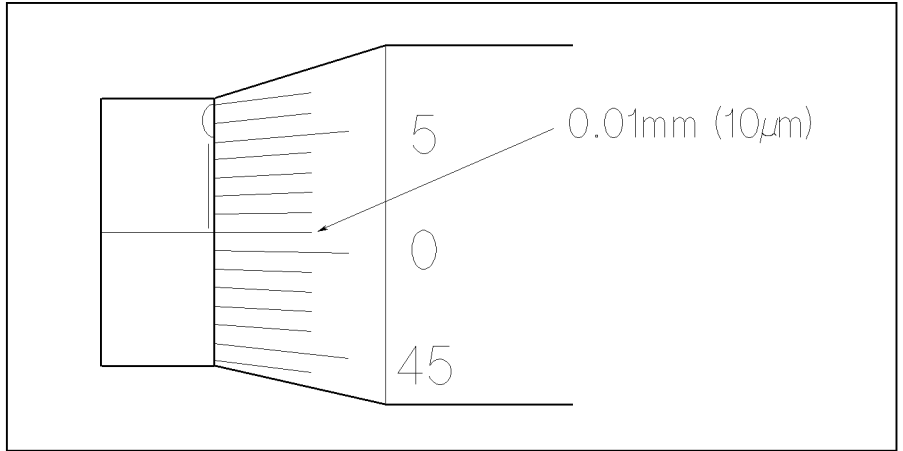

Figure 3-28. The Micrometer Scale Adjusted to 0.01 mm

7. Measure the capacitance.
8. If the measured capacitance value is within the limits listed in Table 3-3, adjustment is not necessary. If the capacitance value is out of limits, go to the next step to make the electrodes parallel.

**Table 3-3.
Measured Capacitance Limits When the
Micrometer is Set to 0.01 mm**

Electrode	Capacitance Value
Electrode-A	700 pF to 1000 pF
Electrode-B	12 pF to 17 pF

9. Carefully turn the three adjustment screws cw or ccw until the measured capacitance value is within the limits listed in Table 3-3.

Caution



Stop turning the screw if the capacitance value becomes negative or extremely high, or the dissipation factor (D) increases suddenly (the electrodes are shorted). In this case, immediately turn the screws ccw to separate the electrodes. If the screw is turned further, it may damage the micrometer and the surface of electrodes.

Accurate Adjustment in Horizontal Position

When the Non-contacting Electrode method (Air Gap method) is used, perform this adjustment after performing the “Rough Adjustment to Make Electrodes Parallel”. The procedure is as follows:

1. Clean the electrodes. This is necessary because the capacitance value is affected by dust. (Refer to “Changing the Guarded/Guard Electrode”.)
2. Perform an OPEN/SHORT correction. (Refer to Appendix C.)
3. Connect the 16451B to an LCR meter or an impedance analyzer and select the capacitance measurement function (C_p) for Circuit mode. (Refer to “Connecting to the Instrument”.)
4. Place the 16451B so that the surface of electrodes is vertical as shown in Figure 3-27
5. Turn the large knob of the micrometer ccw to make enough room between the Guarded/Guard electrode and the Unguarded electrode, and then remove the cover from both electrodes.
6. Turn the small knob of the micrometer cw and adjust it until the micrometer scale indicates 0.01 mm (10 μm) as shown in Figure 3-28.

If the electrodes make contact before 0.01 mm, turn the three adjustment screws ccw to move the Unguarded electrode away from the Guarded/Guard electrode Unguarded electrode till the scale can be adjusted to 0.01 mm.

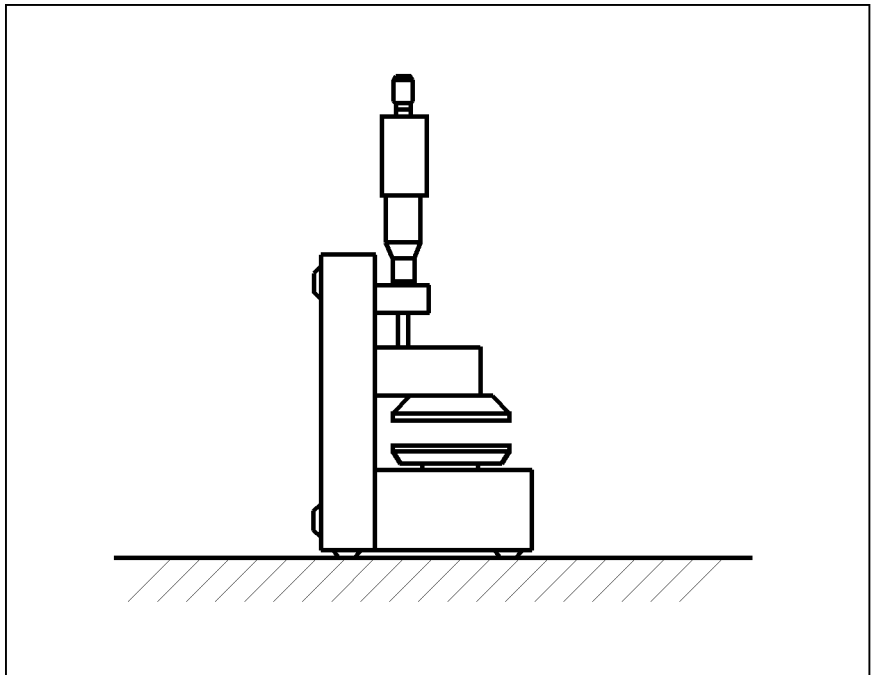

A6003012

Figure 3-29. Horizontal Position

- Starting with the top adjustment screw, turn the three adjustment screws cw in a clockwise sequence until the measured capacitance value is within the limit listed as follows:

**Table 3-4.
Capacitance Point for Starting to Press the
Pressure Adjuster**

Electrode	Capacitance Value
Electrode-A	Greater than 200 pF
Electrode-B	Greater than 5 pF

Caution



Stop turning the screw if the capacitance value becomes negative or extremely high, or the dissipation factor (D) increases suddenly. In this case, immediately turn the screw ccw to separate the electrodes. If the screw is turned further, it may damage the micrometer and the surface of electrodes.

When the measured capacitance value increases widely during turning a screw, turn more slightly the screws.

- Keep pressing the Guarded/Guard electrode pressure adjuster as shown in Figure 3-25 and turn the three screws in a clockwise sequence until the measured capacitance value is within the limits listed in Table 3-5

Table 3-5. Capacitance Limits at Vertical Position

Electrode	Capacitance Value
Electrode-A	700 pF to 1000 pF
Electrode-B	12 pF to 17 pF

Stop turning the screw if the capacitance value becomes negative or extremely high, or the dissipation factor (D) increases suddenly. In this case, immediately turn the screw ccw to separate the electrodes and redo adjustment.

- Place the 16451B so that the surface of electrodes are horizontal and check that the measured capacitance value is within the limit listed in Table 3-6

**Table 3-6.
Capacitance Limits at Horizontal Position**

Electrode	Capacitance Value
Electrode-A	Greater than 700 pF
Electrode-B	Greater than 12 pF

When the measured capacitance value is less than the limit, place the 16451B so that the surface of electrodes are Vertical. Then keep pressing Guarded/Guard pressure adjustment and carefully turn the three screws in a clockwise sequence until the measured capacitance value is within the limits in Table 3-6

If the capacitance value becomes negative or extremely high, or the dissipation factor (D) increases suddenly, place the 16451B so that the surface of electrodes are vertical. Then adjust the Guarded/Guard electrode pressure adjuster. Remove the plug as shown in Figure 3-25 and turn the screw in the pressure adjuster cw to strengthen the pressure. After that return the plug and redo the procedure from step 8.

Note



If the capacitance value measured is not within the limits shown in Table 3-5 even though you repeated steps 7 and 8, change the measured capacitance limits of Table 3-5 to the limits listed in the following table and repeat steps 7 and 8.

Electrode	Capacitance Value
Electrode-A	400 pF to 700 pF
Electrode-B	7 pF to 12 pF

Typical Measurement Procedure by the Measurement Methods

The 16451B can be used for three measurement methods, Contacting Electrode method (Rigid Metal electrode), Contacting Electrode method (Thin Film electrode) and Non-Contacting Electrode method (Air Gap method), to obtain the dielectric constant and dissipation factor. This section provides typical measurement procedure for each measurement method. (For information about how to select the measurement method, refer to “Measurement Method”.)

Caution



DO NOT use the large knob to bring the Guarded/Guard electrode into contact with the Unguarded electrode or test material, doing so will damage the micrometer or the surface of the electrodes. You must use the small knob when you bring an electrode into contact with another electrode or test material. It has a built in clutch which will slip at a specified torque.

Note



You should perform the adjustment in the same environmental conditions as you will measure the test material using the 16451B, because a change of temperature causes mechanical dimensions to change. When you change temperature condition, you should perform the accurate adjustment after temperature conditions have changed, because a change of temperature causes mechanical dimensions to change.

Contacting Electrode Method

For the Contacting Electrode method, the 16451B provides two types of electrodes, Rigid Metal electrodes (Electrode-A and Electrode-B) and Electrode for Thin Film electrodes (Electrode-C and Electrode-D), and provides two diameters for each type, so you should select the electrodes. For more information on selecting electrode, refer to “Contacting Electrode Method (used with Rigid Metal Electrode)” and “Contacting Electrode Method (used with Thin Film Electrode)”. Figure 3-30 shows the model of Contacting Electrode (Rigid Metal electrode) and Figure 3-31 shows the model of Contacting electrode (Thin Film electrode).

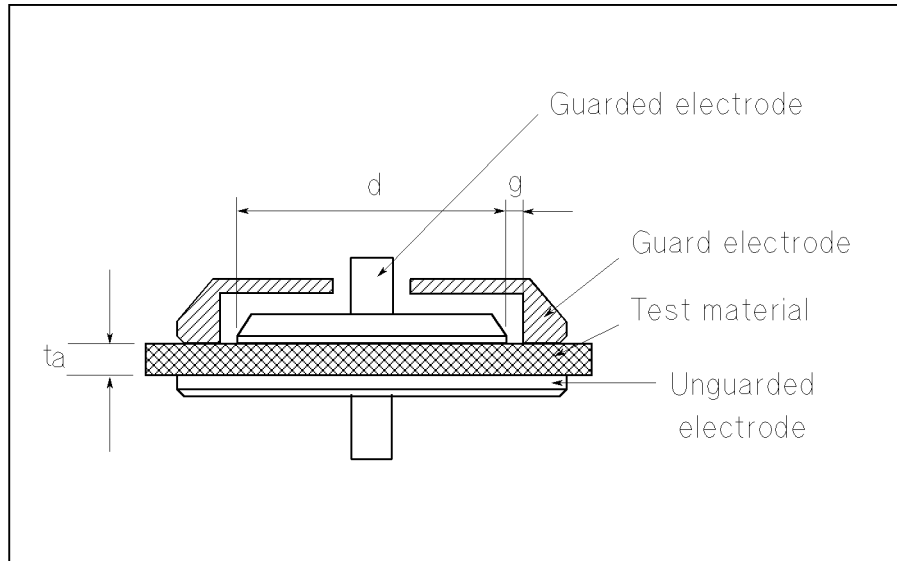

A6003018

Figure 3-30. Contacting Electrode Method (Rigid Metal Electrode)

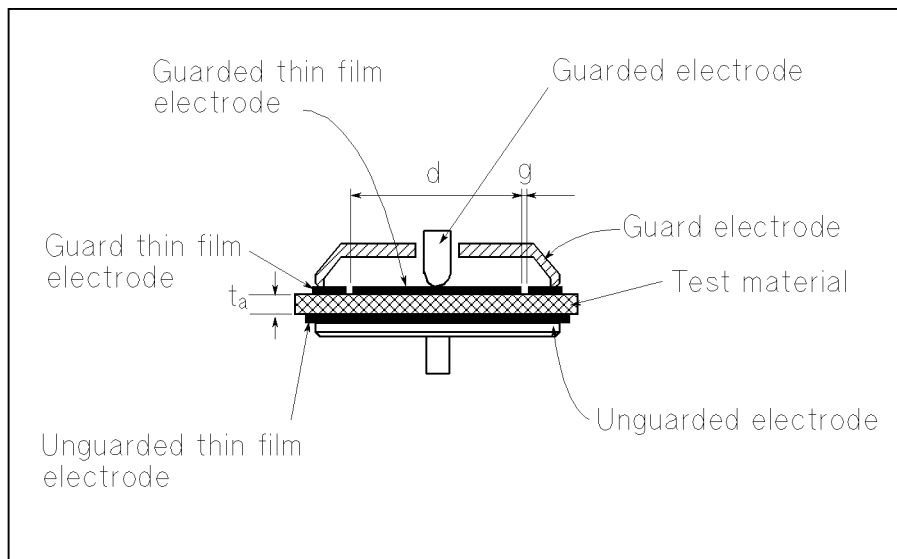

A6003019

Figure 3-31. Contacting Electrode Method (Thin Film Electrode)

Procedure

1. Prepare test material so that the 16451B can measure it.
(When you use Thin Film electrode, you should apply Thin Film electrodes on the surface of the material to be measured. For more information, refer to "Preparation of Test Material".)
2. Connect the 16451B to the instrument. (For more information, refer to "Connecting to the Instrument".)
3. Set up the instrument to measure capacitance (C_p -D).
4. Change to the electrode you will use and perform the rough adjustment. (Refer to "Changing the Guarded/Guard Electrode".)

5. Perform an OPEN/SHORT correction (Refer to “Error Correction”.)
6. When you use the Electrode-A and Electrode-B, adjust the electrodes to be parallel using the accurate adjustment. When you use the Electrode-C and Electrode-D, you can skip this step. (Refer to “Electrode Adjustment”.)
7. Set the test material between the electrodes.
8. Measure the capacitance (C_p) and dissipation factor (D) and then calculate the dielectric constant (ϵ_r) and dissipation factor (D_t) of test material using the following equations.

Equations

$$\begin{aligned}\epsilon_r &= \frac{t_a \times C_p}{A \times \epsilon_o} \\ &= \frac{t_a \times C_p}{\pi \times \left(\frac{d}{2}\right)^2 \times \epsilon_o}\end{aligned}$$

$$D_t = D$$

Where,

C_p Equivalent parallel capacitance [F]

D Dissipation factor

t_a Average thickness of test material [m]

A Area of Guarded electrode [m²]

d Diameter of Guarded electrode [m]

ϵ_o = 8.854×10^{-12} [F/m]

ϵ_r Dielectric constant of test material

D_t Dissipation factor of test material

Note



After you measure the test material (or move the electrode) several times, it is recommended that you check electrode for parallelism (refer to “Check Electrode Parallelism”) and clean the surface of electrodes.

Note



For more information on measuring accurately, refer to “Measurement Error Analysis”.

Non-Contacting Electrode Method

For the Non-Contacting method, the 16451B can perform an Air Gap method. The 16451B provides two sizes of electrodes for the Air Gap method, so you should select the electrode for the material to be tested. For more information on selecting electrodes, refer to “Measurement Method”. Figure 3-32 shows a simple model of the Non-Contacting method.

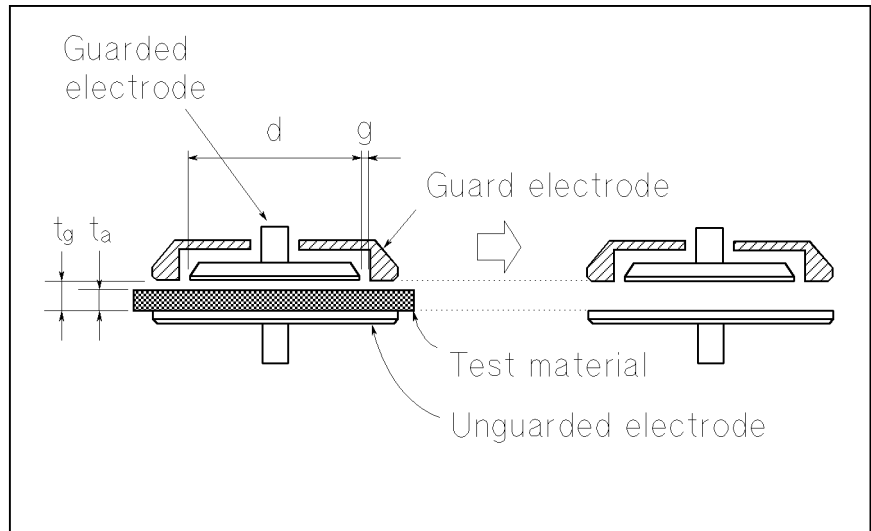

A6003020

Figure 3-32. Non-Contacting Electrode Method (Air Gap Method)

Procedure

1. Prepare the test material so that the 16451B can measure it. (For more information, refer to “Preparation of Test Material”.)
2. Connect the 16451B to the instrument.(For more information, refer to “Connecting to the Instrument”.)
3. Set up the instrument to measure capacitance (C_s -D).
4. Change to the electrode you will use and perform the Rough Adjustment. (Refer to “Changing the Guarded/Guard Electrode”.)
5. Perform an OPEN/SHORT correction
6. Adjust the electrodes to be parallel using the Accurate Adjustment. (Refer to “Electrode Adjustment”.)
7. Set the test material between the electrodes.
8. Adjust the small knob of the micrometer to set the gap between Guarded/Guard electrode and Unguarded electrode to t_g so that the gap distance between the Guarded/Guard electrode and the test material is less than 10 % of thickness of the test material.
9. Measure capacitance (C_{s2}) and dissipation factor (D_2)
10. Carefully remove the test material.
11. Measure capacitance (C_{s1}) and dissipation factor (D_1) and then calculate the dielectric constant (ϵ) and dissipation factor (D_t) using the following equations.

Equations

$$\epsilon_r = \frac{1}{1 - \left(1 - \frac{C_{s1}}{C_{s2}}\right) \times \frac{t_g}{t_a}}$$
$$D_t = D_2 + \epsilon_r \times (D_2 - D_1) \times \left(\frac{t_g}{t_a} - 1\right)$$

Where,

C_{s1}	Capacitance without test material inserted [F]
D_1	Dissipation factor without test material inserted
t_g	Gap between Guarded/Guard electrode and Unguarded electrode [m]
C_{s2}	Capacitance with test material inserted [F]
D_2	Dissipation factor with test material inserted
t_a	Average thickness of test material [m]
ϵ_r	Dielectric constant of test material
D_t	Dissipation factor of test material

Note  After you measure the test material (or move the electrode) several times, it is recommended to check for electrode parallelism (refer to “Check Electrode Parallelism”) and clean the surface of electrodes.

Note  For more information on accurate measurement, refer to “Measurement Error Analysis”.

Check Electrode Parallelism

This section describes the procedure to check that the electrodes are parallel. When you measure test materials several times (or move the electrode) using Electrode-A or Electrode-B, perform the following procedure to check for electrode parallelism.

- Remove the covers of both electrodes.
- Turn the small knob of the micrometer cw and adjust it until the micrometer scale indicates 0.01 mm (10 μ).
- Measure the capacitance

If the measured capacitance value is within the limits listed in Table 3-7, the check is finished. If the capacitance value is out of limits, perform the Accurate Adjustment as shown in “Accurate Adjustment to Make Electrodes Parallel”.

Table 3-7.
Measured Capacitance Limits for Check Electrode Parallelism

Electrode	Capacitance Value
Electrode-A	700 pF to 1000 pF
Electrode-B	12 pF to 17 pF

Measurement Examples

Caution



This section describes two practical examples of measuring dielectric constant using the 16451B with the 4194A Impedance/Gain-phase Analyzer, and with the 4284A Precision LCR meter.

DO NOT use the large knob to bring the Guarded/Guard electrode into contact with the Unguarded electrode or test material, doing so will damage the micrometer or the surface of the electrodes. You must use the small knob when you bring the electrode into contact with another electrode or test material. It has a built in clutch which will slip at a specified torque.

Using the 4194A

In this example, the Contacting Electrode method (Thin Film electrode, Electrode-C or Electrode-D) is used. This sample procedure performs OPEN/SHORT compensation, measures capacitance of test material from 1 kHz to 10 MHz and derives the dielectric constant of the test material.

1. Apply thin film electrodes to the surface of the material to be measured.
2. Replace the electrodes (Electrode-C or Electrode-D) you will use and adjust to make the electrodes parallel.
3. Set the CABLE LENGTH switch to the 1 m position.
4. Connect the 16451B to the 4194A's Impedance UNKNOWN terminals and place the 16451B so that the surfaces of electrodes are vertical.
5. Press **LINE** to turn the 4194A ON, if it is already ON, you must turn it OFF once and then turn it ON again. Then press the blue **●** and press **R**, **S**, **T**, **ENTER/EXECUTE** to reset the 4194A.
6. Press **FUNCTION**, **IMPEDANCE**, **more**, **Cp-D** (Parallel capacitance and Dissipation factor) to select the Cp-D measurement function.
7. Press **SWEEP**, **LOG SWEEP** to select the Log sweep mode.
8. Press **START**, **1**, **kHz**, **STOP**, **1**, **0**, **MHz** to set the START and STOP frequencies for the sweep frequency range.
9. Put the attachment for error compensation with the cover on the Guarded/Guard electrode then turn the small knob cw to bring it into contact with the Unguarded electrode.
10. Press **COMPEN**, **ZERO OPEN**, **ENTER/EXECUTE** to perform an OPEN compensation.
11. After Calibration completed is indicated and you hear the beeping, remove the attachment.
12. Remove the cover on the attachment for error compensation and put the attachment on the Unguarded electrode and bring the Guarded/Guard electrode into contact with it.
13. Press **COMPEN**, **ZERO SHORT**, **ENTER/EXECUTE** to perform a SHORT compensation.

14. After Calibration completed is indicated and you hear a beeping, remove the attachment.
15. Press **OPEN OFS on/off** and **SHRT OFS on/off** to make compensation data valid, then the softkey indicators will turn green.
16. Attach the test material with the thin film electrodes into the electrodes of the 16451B.
17. Press **(START)**, then the 4194A displays C_p -D measurement result.
18. After the sweep is completed, press **(DISPLAY)**, **more**, **AUTO SCALE A**, **more**, **AUTO SCALE B** then the screen will be displayed as in Figure 3-33.
19. In this case, the test material's diameter is 38 mm and thickness is 100 μm , so the dielectric constant (ϵ_r) can be obtained by using the following equation: (Refer to "Contacting Electrode Method (used with Thin Film Electrode)" in "Measurement Method")

$$\epsilon_r = \frac{1.00 \times 10^{-4}}{\pi \times \left(\frac{3.8 \times 10^{-2}}{2}\right)^2 \times 8.854 \times 10^{-12}} \times C_p$$

$$\simeq 9.96 \times 10^9 \times C_p$$

Where,

C_p Measured equivalent parallel capacitance value

Hence, press the blue **(\odot)**, **(A)**, **(\equiv)**, **(9)**, **(.)**, **(9)**, **(6)**, **(EEX)**, **(9)**, **(*)**, **(A)**, **(ENTER/EXECUTE)** to calculate the dielectric constant.

20. Press **(DISPLAY)**, **more**, **AUTO SCALE A** then the measurement result is displayed as shown in Figure 3-34 .

Note



By using the 4194A's ASP (Auto Sequence Program) function it is possible to derive the dielectric constant from the capacitance measurement results automatically. "Sample ASP Program for the 4194A" in Appendix D lists the ASP program for the 4194A to perform the procedure automatically.

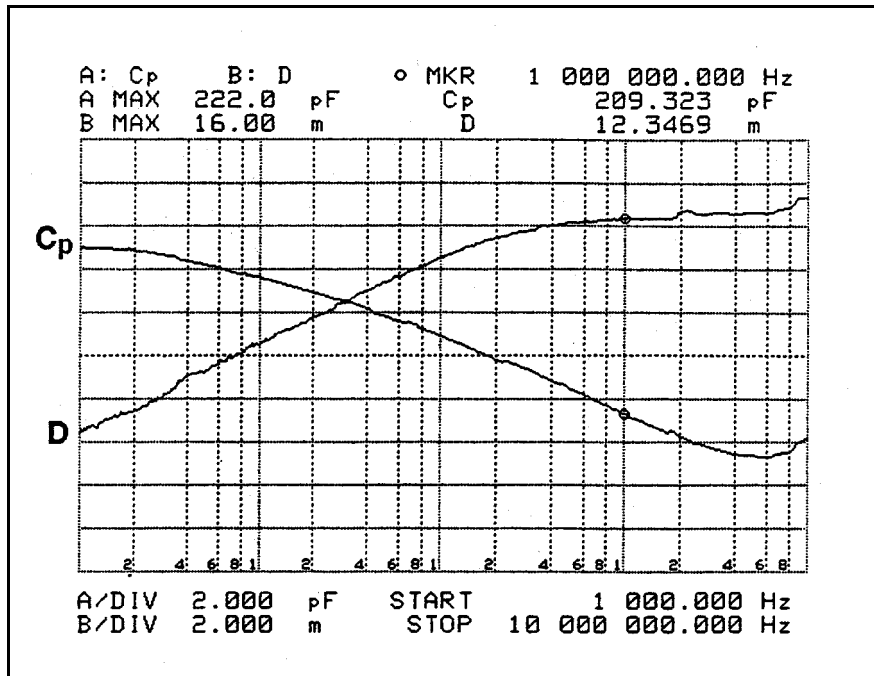

Figure 3-33.
Sample Result of Cp-D Measurement Using the 4194A

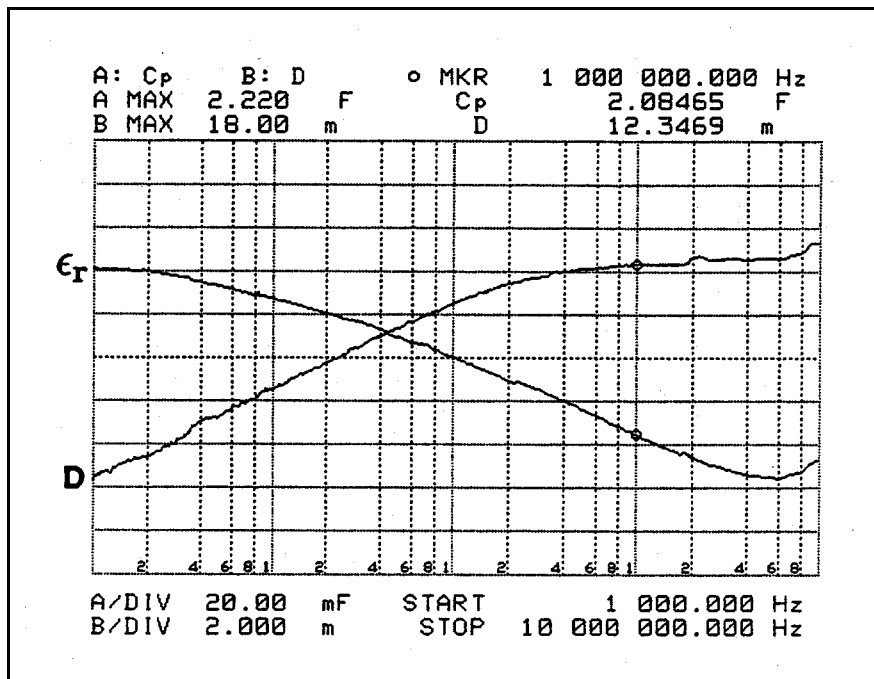

Figure 3-34.
Sample Result of Dielectric Constant Using the 4194A

Using the 4284A

In this example, the Non-Contacting method (Air Gap method) and Electrode-A or Electrode-B is used. The sample procedure performs OPEN/SHORT compensation and measures the capacitance of the test material at 1 MHz.

1. Replace the electrodes (Electrode-A or Electrode-B) you will use and adjust the electrodes for parallelism.
2. Press **MEAS SETUP**, and **CORRECTION** and move the cursor to the CABLE: field and press **1 m**.
3. Connect the 16451B to the 4284A's Unknown Terminals and place the 16451B so that the surface of electrodes is horizontal.
4. Press **DISPLAY FORMAT** and if the FUNC: field does not indicate Cs-D move the cursor to the FUNC: field and press **Cs-D**.
5. Move the cursor to the FREQ: field and press **1**, **MHz** to specify the measurement frequency.
6. Put the attachment for error compensation with the cover on the Guarded/Guard electrode then turn the small knob cw to bring the attachment into contact with the Unguarded electrode.
7. Press **MEAS SETUP**, and **CORRECTION**. Move the cursor to the OPEN: field and press **MEAS OPEN** to perform an OPEN correction measurement.
8. After indicating Open measurement completed and beeping, press **ON** to validate the OPEN correction.
9. Turn the small knob ccw to remove the attachment.
10. Put the attachment for error compensation without the cover on the Unguarded electrode then turn the small knob cw to bring the Guarded/Guard electrode into contact with the attachment.
11. Move the cursor to the SHORT: field and press **MEAS SHORT** to perform SHORT correction measurement.
12. After indicating "Short measurement completed" and beeping, press **ON** to validate the SHORT correction and remove the attachment.
13. Press **DISPLAY FORMAT** to start the measurement.
14. Using the small knob of the 16451B, set the micrometer's scale to 10 μm and adjust to set the electrodes accurately parallel. (For more information of this procedure, refer to "Accurate Adjustment to Make Electrodes Parallel")
15. After adjusting, put the test material into the gap between the electrodes.
16. Set the micrometer's scale to (t_g) so that the gap distance between the Guarded/Guard electrode and the test material is below 10 % of thickness of the test material..
17. Press **DISPLAY FORMAT** then the 4284A starts the measurement and indicates the measurement capacitance value.

18. Record this measurement value as C_{s2} .
19. Remove the test material carefully and measure the capacitance of the air gap.
20. Record this measurement value as C_{s1} .
21. You can obtain the dielectric constant (ϵ_r) using the following equation: (Refer to “Non-contacting Electrode Method (Air Gap Method)” in “Measurement Method”)

$$\epsilon_r = \frac{1}{1 - \left(1 - \frac{C_{s1}}{C_{s2}}\right) \times \frac{t_g}{t_a}}$$

For example, $C_{s1} = 4.055$ pF, $C_{s2} = 6.780$ pF, $t_a = 2.01$ mm and $t_g = 2.20$ mm then the calculated dielectric constant ϵ_r is 2.00.

Note



The “Sample Program for the 4284A” in Appendix D lists a sample BASIC program that runs on the 9000 series 300 Engineering Workstation. The sample program controls the 4284A via GPIB and automatically performs the following operation procedure. For more information on the 4284A, such as GPIB commands, refer to the 4284A Operation Manual.

Measurement Error Analysis

This section describes error factors involved in dielectric constant measurement using the Contacting Electrode method and Non-contacting Electrode method, and how to perform measurements with minimum error.

Note



All data shown in this section, such as measurement accuracy, and tolerance of electrode diameter, are typical values and are not guaranteed.

Error Factor using Contacting Electrode Method

The dielectric constant of a test material is derived from measured capacitance value. When using the Contacting Electrode method, the dielectric constant ϵ_r of a test material is obtained using the following equation.

$$\epsilon_r = \frac{t_a \times C_p}{\pi \times \left(\frac{d}{2}\right)^2 \times \epsilon_o}$$

Where,

C_p Equivalent parallel capacitance [F]

t_a Average thickness of test material [m]

d Diameter of Guarded electrode [m]

ϵ_o = 8.854×10^{-12} [F/m]

The error factors included in the above parameters are as follow:

Capacitance measurement Error

This error is determined by the measurement accuracy of the LCR meter or impedance analyzer used. Measurement accuracy of LCR meters and impedance analyzers depends on the measurement frequency and the measured impedance value. Generally, an LCR meter and an impedance analyzer can accurately measure capacitance above 1 pF. (For measurement frequency range of them, refer to Table 1-2.) For more information on measurement accuracy of LCR meters and impedance analyzers, refer to their *Operation Manual* or *Technical Data Sheet*.

Tolerance of Guarded Electrode Diameter

This error depends on the electrodes mechanical accuracy. The typical error for Electrode-A (ϕ 38 mm electrode) and Electrode-B (ϕ 5 mm electrode) are given in Table 3-8.

Table 3-8. Tolerance of Electrode Diameter

Electrode	Tolerance (typical)
Electrode-A (ϕ 38 mm Electrode)	approximately $\pm 0.13\%$
Electrode-B (ϕ 5 mm Electrode)	approximately $\pm 1.0\%$

Gap Error

This error consists of two factors as following:

- Measurement Error of Test Material's Thickness (Error caused by Micrometer) : Thickness measurement of the test material depends on accuracy of the micrometer used. To reduce this error, measure the thickness at several points of the measured area of the test material using an accurate micrometer. Do not use the micrometer equipped with the 16451B.
- Parallelism and Flatness of Electrodes and Test Material : When contacting the MUT directly with the electrodes, an airgap is formed between the MUT and the electrodes. No matter how flat and parallel both sides of the MUT is fabricated, an airgap will still form. This airgap is the cause for measurement error because the measured capacitance will be the sum of the capacitance of the dielectric material and the airgap. The relationship between the airgap's thickness and measurement error is determined by the equation shown in Figure 3-35. Measurement error is a function of the relative permittivity (ϵ_r') of the MUT, thickness of the MUT (d), and the airgap's thickness (t). Sample results of measurement error have been calculated in Table 3-9. Notice that the effect is greater with thin materials and materials with high permittivity.

This airgap effect can be eliminated, by applying a thin film electrode to the surfaces of the dielectric material. An extra step is required for material preparation (fabricating a thin film electrode), but the most accurate measurements can be performed.

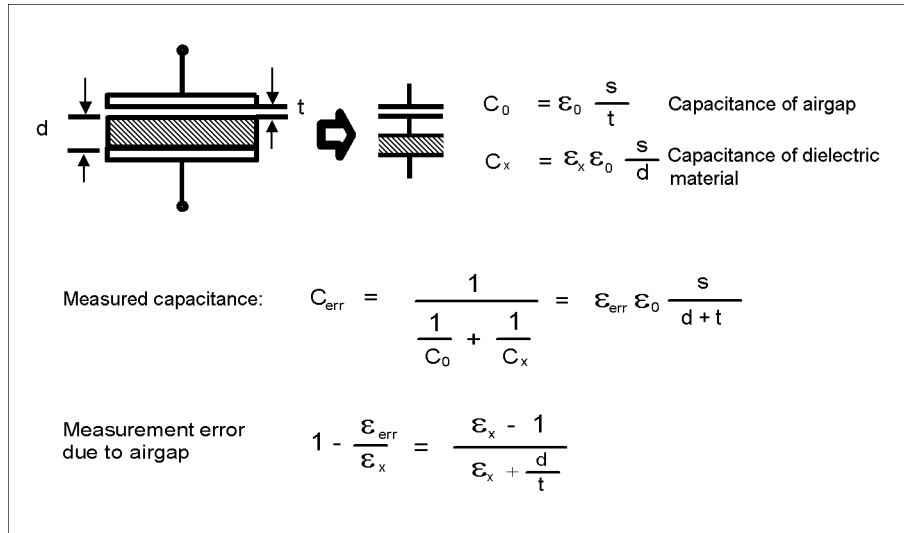

Figure 3-35. Airgap Effects

Table 3-9. Measurement Error Caused by Airgap

t/d	er' = 2	er' = 5	er' = 10	er' = 20	er' = 50	er' = 100
0.001	0.1%	0.4%	1%	2%	5%	9%
0.005	0.5%	2%	4%	9%	20%	33%
0.01	1%	4%	8%	16%	33%	50%
0.05	5%	16%	30%	48%	70%	83%
0.1	8%	27%	45%	63%	82%	90%

Effective Area of Electrode

The guard electrode reduces the error caused by stray capacitance at the edge of the electrodes as shown in "Guard Electrode". But the guard electrode cannot perfectly eliminate the error. This error makes the apparent area of the guarded electrode larger. To reduce the error, divide the dielectric constant value by the effective area constant. The effective area constant represents the increase of electrode area caused by stray capacitance, and is as follows:

when $\epsilon = \epsilon_a$

$$\alpha_a = \left(1 + \frac{g}{d} \times B_a\right)^2$$

when $\epsilon \gg \epsilon_a$

$$\alpha_b = \left(1 + \frac{g}{d} \times B_b\right)^2$$

Where,

$$B_a = 1 - \frac{2}{\pi} \times \arctan\left(\frac{g}{2t}\right) + \frac{2}{\pi} \times \frac{t}{g} \times \ln\left(1 + \left(\frac{g}{2t}\right)^2\right)$$

$$B_b = 1 - \frac{4}{\pi} \times \frac{t}{g} \times \ln\left[\cosh\left(\frac{\pi g}{4t}\right)\right]$$

- g* Gap between Guard electrode and Guarded electrode [m]
(refer to Figure 3-8, Figure 3-12 and Figure 3-16)
- d* Diameter of Guarded electrode
- t* For Contacting Electrode method, thickness of the test material (= t_a) [m].
For Non-contacting Electrode method, gap between Guarded/Guard electrode and Unguarded electrode (= t_g) [m]

Table 3-10 lists the effective area constants α_a , α_b calculated for Electrode-A ($\phi 38$ mm electrode) and Electrode-B ($\phi 5$ mm Electrode). To reduce the error caused by stray capacitance at the edge, divide α_a or α_b into equation to obtain dielectric constant as shown in following equation

$$\epsilon_r = \frac{t_a \times C_p}{\pi \times \left(\frac{d}{2}\right)^2 \times \epsilon_o \times \alpha}$$

Table 3-10. Effective Area Constant

Electrode distance [mm]	$\alpha_a (\epsilon = \epsilon_a)$		$\alpha_b; (\epsilon \gg \epsilon_a)$	
	$\phi 38$ mm	$\phi 5$ mm	$\phi 38$ mm	$\phi 5$ mm
10	1.0105	1.0526	1.0105	1.0524
9	1.0105	1.0526	1.0105	1.0524
8	1.0105	1.0525	1.0105	1.0523
7	1.0105	1.0525	1.0104	1.0523
6	1.0105	1.0525	1.0104	1.0522
5	1.0105	1.0525	1.0104	1.0521
4	1.0105	1.0524	1.0103	1.0520
3	1.0104	1.0523	1.0103	1.0518
2	1.0104	1.0521	1.0101	1.0513
1	1.0102	1.0516	1.0097	1.0500
0.9	1.0102	1.0515	1.0096	1.0497
0.8	1.0101	1.0513	1.0095	1.0493
0.7	1.0101	1.0511	1.0094	1.0488
0.6	1.0100	1.0508	1.0092	1.0482
0.5	1.0099	1.0505	1.0089	1.0473
0.4	1.0097	1.0499	1.0085	1.0460
0.3	1.0095	1.0490	1.0079	1.0438
0.2	1.0089	1.0473	1.0068	1.0397
0.1	1.0076	1.0423	1.0044	1.0293
0.09	1.0073	1.0413	1.0040	1.0274
0.08	1.0071	1.0401	1.0036	1.0253
0.07	1.0067	1.0387	1.0032	1.0230
0.06	1.0063	1.0387	1.0028	1.0203
0.05	1.0058	1.0346	1.0023	1.0173
0.04	1.0052	1.0317	1.0019	1.0140
0.03	1.0045	1.0278	1.0014	1.0106
0.02	1.0035	1.0225	1.0009	1.0071
0.01	1.0022	1.0147	1.0005	1.0035

(ϕ means diameter.)

Error Factor using Non-contacting Electrode Method

The dielectric constant of a test material is derived from two capacitance values, capacitance without a test material inserted and capacitance with a test material inserted, when using the Non-contacting Electrode method. The dielectric constant ϵ_r of a test material is obtained using the following equation.

$$\epsilon_r = \frac{1}{1 - \left(1 - \frac{C_{s1}}{C_{s2}}\right) \times \frac{t_g}{t_a}}$$

Where,

C_{s1} Capacitance without test material inserted [F]

C_{s2} Capacitance with test material inserted [F]

t_g Gap between Guarded/Guard electrode and Unguarded electrode [m]

t_a Thickness of test material [m]

The error factors included in the above parameters used are as follows:

Capacitance measurement Error

This error is determined by the measurement accuracy of LCR meters and impedance analyzers used. For more details, refer to “Capacitance measurement Error” in “Error Factor using Contacting Electrode Method”.

Gap Error

This error consists of three factors as follows:

- **Measurement Error of Test Material’s Thickness (Error caused by Micrometer) :** This error is included in thickness (t_a) of the test material. Thickness measurement of the test material depends on accuracy of the micrometer used. To reduce this error, measure the thickness at several points of the measured area of the test material using an accurate micrometer. Do not use the micrometer equipped with the 16451B.
- **Parallelism and Flatness of Electrodes and Test Materials :** This error is included in the thickness (t_a) of a test material and gap (t_g) between Guarded/Guard electrode and Unguarded electrode. When parallelism and flatness of electrodes of the test material are bad, air film (gaps between surfaces of electrode and a test material) causes error. To reduce this error, prepare the test material to make surfaces of the material parallel and flat and adjust to make electrode parallel as accurately as possible.
- **Error in Gap between Electrodes :** This error is included in the gap (t_g) between Guarded/Guard electrode and Unguarded electrode. It is caused by difference of scale of the micrometer from actual distance between electrodes and depends on accuracy of micrometer which set the gap between electrodes.

To reduce this error, perform error correction as follows. This correction obtains an equivalent distance error of electrode gap distance by comparing the measured capacitance value of air gaps

between electrodes and their theoretical value. Use the following procedure:

1. Measure the capacitance at three different electrode distances, such as 40 μm , 50 μm , and 60 μm .
2. Calculate the theoretical capacitance value of each distance. The theoretical capacitance value C_t can be obtained as follows.

$$C_t = \epsilon_a \times \epsilon_0 \times \frac{\pi \times (d/2)^2}{t_{set}} \times \alpha_a$$

Where,

C_t Theoretical capacitance value [F]

ϵ_a Dielectric constant of air (= 1.00059)

ϵ_0 = 8.854 $\times 10^{-12}$ [F/m]

α_a Effective area coefficient of electrode when the electrode distance is t_{set} .
(Refer to “Effective Area of Electrode” in “Error Factor using Contacting Electrode Method”.)

t_{set} Reading value of the electrode distance on the micrometer [m]

3. Calculate the equivalent distance error at each electrode distance. The equivalent distance error of each electrode distance Δt_e can be obtained as follows:

$$\Delta t_e = \left(\frac{C_t}{C_m} - 1 \right) \times t_{set} \quad [m]$$

Where,

C_m Measured capacitance value [F]

4. Average equivalent distance error The average of equivalent electrode distance error Δt_a is derived as follows.

$$\Delta t_a = \frac{\Delta t_{40} + \Delta t_{50} + \Delta t_{60}}{3} \quad [\mu m]$$

Where,

Δt_{40} Equivalent distance error Δt_e at 40 μm

Δt_{50} Equivalent distance error Δt_e at 50 μm

Δt_{60} Equivalent distance error Δt_e at 60 μm

The equivalent electrode distance t_{eq} can be derived from a set value of micrometer t_{set} and equivalent distance error Δt_a shown as follows:

$$t_{eq} = t_{set} + \Delta t_a$$

The compensated dielectric constant is obtained as follows:

$$\epsilon_r = \frac{1}{1 - \left(1 - \frac{C_{s1}}{C_{s2}} \times \frac{\alpha_b}{\alpha_a} \right) \times \frac{t_{eq}}{t_a}}$$

Where, α_a and α_b are Effective area constants. For more information, refer to “Effective Area of Electrode”.

Compensation Result Example

If the measured capacitance values are 227.6 pF, 185.2 pF and 156.58 pF, when the set values of the micrometer are 40 μm , 50 μm , and 60 μm . Each theoretical capacitance values and equivalent electrode distance errors are listed in Table 3-11.

Table 3-11. Compensation Result Example

t_{set} [μm]	C_m [pF]	C_t [pF]	Δt_e [μm]
40	227.60	252.48	4.4
50	185.20	202.11	4.6
60	156.58	168.51	4.6

So, the average of equivalent electrode distance error is obtained as follows:

$$\Delta t_a = \frac{4.6 + 4.6 + 4.4}{3} \simeq 4.5 \text{ } [\mu\text{m}]$$

In this case, the equivalent electrode distance is as follows:

$$t_{eq} = t_{set} + 4.5\mu \text{ } [m]$$

Use the equivalent electrode distance (t_{eq}) to accurately calculate accurately the dielectric constant ϵ_r .

Effective Area of Electrode

This error is included in capacitance values measured C_{s1} and C_{s2} . It is caused by the stray capacitance at electrode's edge even though a guard electrode is used. To reduce the error, divide capacitance value C_{s1} and C_{s2} by effective area constants α_a and α_b as shown in following equation.

$$\epsilon_r = \frac{1}{1 - \left(1 - \frac{C_{s1}}{C_{s2}} \times \frac{\alpha_b}{\alpha_a}\right) \times \frac{t_{eq}}{t_a}}$$

Where, t_{eq} is the equivalent electrode distance. For more information, refer to "Effective Area of Electrode" in "Error Factor using Contacting Electrode Method" and "Gap Error".

Service

Introduction

This chapter gives the service information for the 16451B. Service information covers Assembly Replacement and Troubleshooting.

Assembly Replacement

This section gives 16451B assembly and disassembly hints, and lists the replaceable parts.

Assembly and Disassembly Hints

The assemblies in the 16451B are secured using metric threaded fasteners. All fasteners used in the 16451B, can be removed using medium and small pozidrive screwdrivers and a 2.5 mm hex key. A 2.5 mm hex key (Agilent PN 8710-1181) is included with the 16451B.

Slide Stand Assembly

Do not remove any part of the Slide Stand Assembly (Agilent PN 16451-60002) shown in Figure 4-1. Once the Slide Stand Assembly is disassembled, it cannot be reassembled, because special tools are required for reassembly.

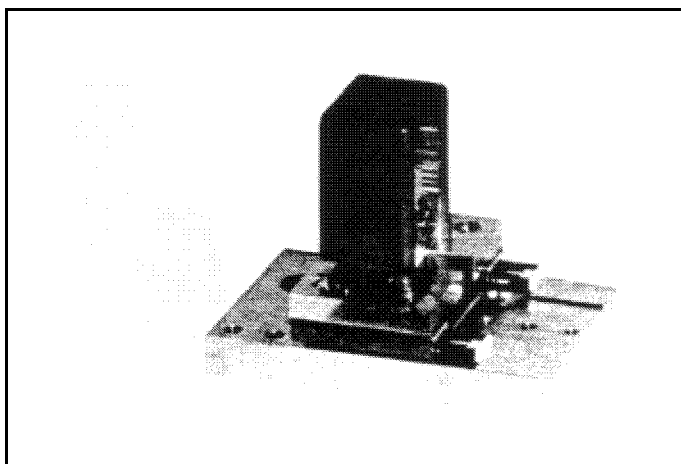
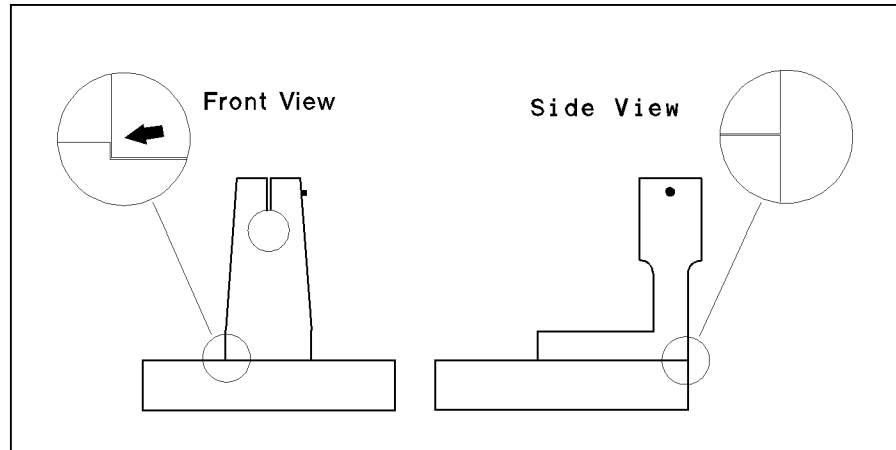

Figure 4-1. Slide Stand Assembly

Micrometer Stand Replacement

When replacing the micrometer stand, press it against the slide stand assembly's guide and align the back edge of the micrometer stand and the slide stand assembly, as shown in Figure 4-2.



A6004001

Figure 4-2. Micrometer Stand Replacement

Micrometer Replacement

When replacing the micrometer, put the micrometer completely into the micrometer stand and turn the fine scale adjustment line until it is facing vertical, as shown in Figure 4-3. Then tighten the micrometer stand's set screw to firmly attach the micrometer to the stand. The proper tightening torque is 3 kgf/cm. (About 3 kgf/cm may be applied to the screw when the furnished hex key is used.) If the screw is tighten too much, the micrometer will not function smoothly.

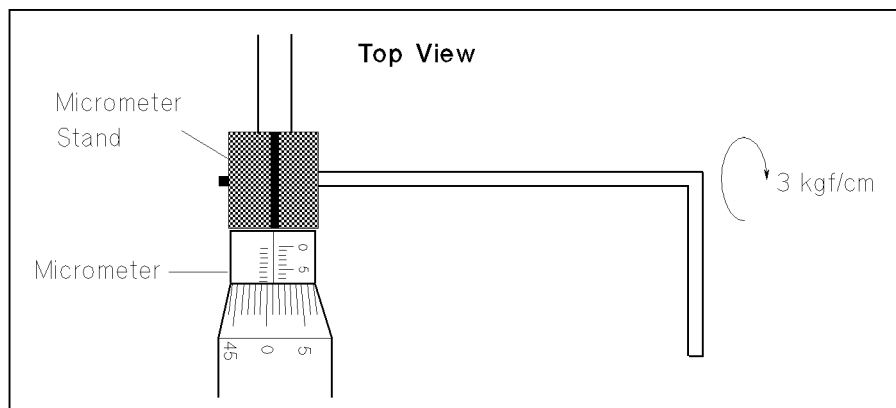

A6004002

Figure 4-3. Micrometer Replacement

Replaceable Parts List

Table 4-1 to Table 4-5 list the replaceable parts. Parts listed in these tables can be ordered from your nearest Agilent Technologies Service Office. Ordering information should include the Agilent part number and the quantity required.

Table 4-1. Replaceable Parts List (1 of 5)

Reference Designator	Part Number	Qty	Description
1	Refer to Table 4-3	1	
2	Refer to Table 4-4	1	
3	8710-1889 2190-0586 0515-0909	1 2 2	Angle Washer Screw
4	8750-0373	1	Micrometer
5	16451-04001 0515-0914	1 1	Cover Screw
6	16451-00602 0515-0914	1 1	Plate Screw
7	16451-24001	1	Unguarded Electrode
8	16451-25001	1	Insulator
9	16451-24008	1	Plate

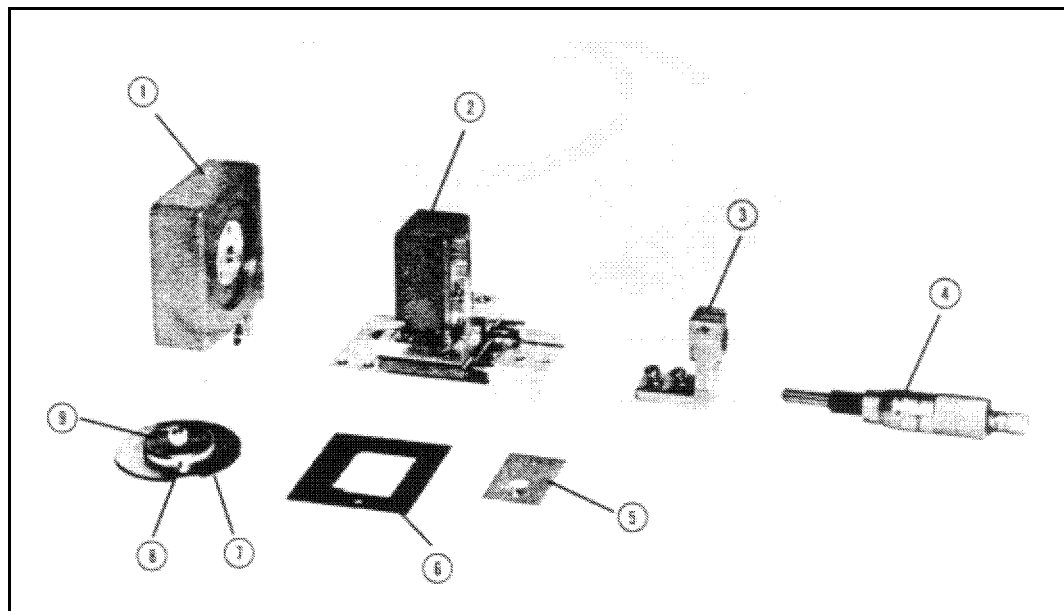

Table 4-2. Replaceable Parts List (2 of 5)

Reference Designator	Part Number	Qty	Description
1	16541-04003	1	Cover Bottom
	0403-0427	8	Bumper Foot
	0515-0914	4	Screw
2	16451-04002	1	Cover Top
3	16451-61002	1	Cable Assembly
4*	16047-40000	1	Stopper
	2190-0206	1	Washer
	0515-1550	1	Screw
5*	16451-04004	1	Cover Top
	0515-0914	2	Screw

*:These parts are included in the 16451-61002.

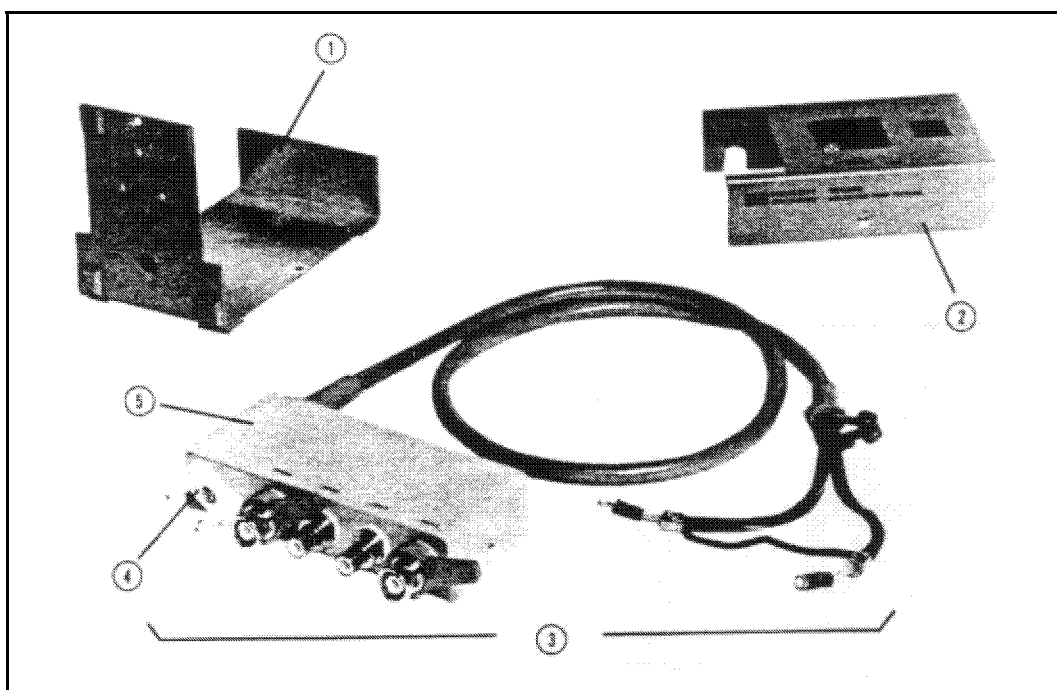

Table 4-3. Replaceable Parts List (3 of 5)

Reference Designator	Part Number	Qty	Description
1	16451-20002	1	Base
2-A	16451-25007	1	Spacer
2-B	16451-61602	1	Cable Assembly
2-C	1460-2237	1	Spring
2-D	16451-25004	1	Bushing
2-E	0515-1321	1	Screw
3	0515-1321 16451-25008	3 3	Screw* Spacer
4-A	1460-2238	1	Spring
4-B	16451-25009	1	Rod
4-C	0515-1321	1	Screw
4-D	16451-25011	1	Rod
4-E	6960-0147	1	Plug Hole
5	0515-1550	1	Screw

*:Apply a drop of Lock-Tite (Agilent PN 0470-0013) to the screws, when replacing them.

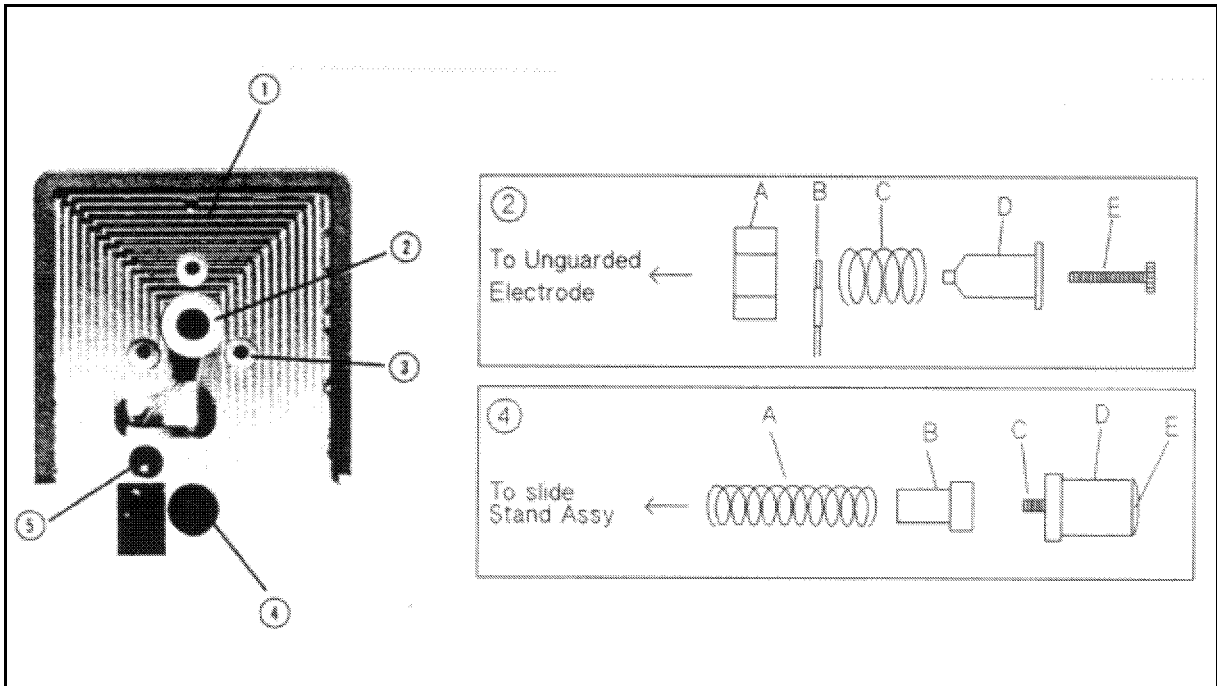

Table 4-4. Replaceable Parts List (4 of 5)

Reference Designator	Part Number	Qty	Description
1	16451-60002	1	Slide Stand Assembly
2-A	16451-25002	1	Spacer
2-B	16451-61602	1	Cable Assembly
2-C	2190-0584	1	Washer
2-D	0515-1321	1	Screw
2-E	16451-25006	1	Spacer
3	0515-1550	1	Screw

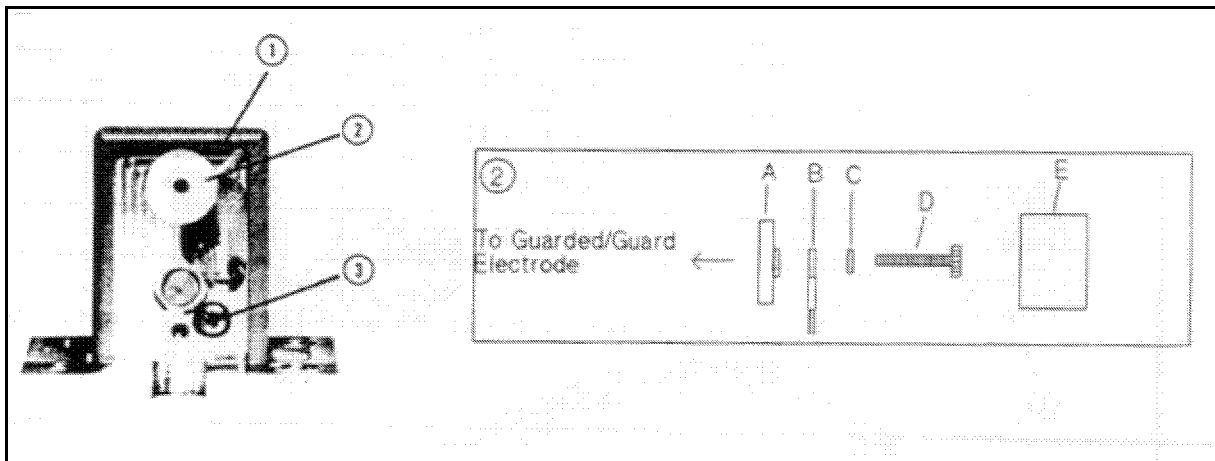

Table 4-5. Replaceable Parts List (5 of 5)

Description	Part Number
Electrode-A	16451-60011
Electrode-B	16451-60013
Electrode-C	16451-60012
Electrode-D	16451-60014
Error Compen. Attachment	16451-24011
Cover 56 mm	16451-25021
Cover 20 mm	16451-25022
Hex Key	8710-1181
Carrying Case	16451-60001

Electrodes A and C include a 56 mm Cover. Electrodes B and D include a 20 mm Cover.

- Electrode-A: 38 mm Guarded/Guard electrode
- Electrode-B: 5 mm Guarded/Guard electrode
- Electrode-C: Guarded/Guard electrode for large thin film electrode
- Electrode-D: Guarded/Guard electrode for small thin film electrode

Troubleshooting

Mechanical Trouble

When the 16451B is mechanically defective, replace the defective parts, refer to “Assembly Replacement”, and confirm that the electrode distance can be changed smoothly from 0 to 10 mm. If the electrode does not move smoothly it may be because the cables are obstructing the operation.

Electrical Trouble

When the 16451B is electrically defective, check its cable connections, refer to Figure 4-4. The connection check points are as follows:

- The Lcur and Lpot Center conductors are connected to the Guarded Electrode.
- The Hcur and Hpot Center conductors are connected to the Unguarded Electrode.
- The Lcur, Lpot, Hcur, and Hpot outer conductors are connected to the body. (The cables' shields are connected to the body with screws.)
- The Guard Electrode is connected to the body.
- Insulation resistance between the Lpot center conductor and the Hpot center conductor is greater than 1 M Ω .
- Insulation resistance between the center conductors and the outer conductors is greater than 1 M Ω .

If the cable connections are correct, the electrodes may be defective.

Operation Check

The Electrode Parallel Accurate Adjustment, described in “Electrode Adjustment” in Chapter 3, can be used for the before and after repair operation check. The adjustment cannot be completed when the 16451B is electrically defective.

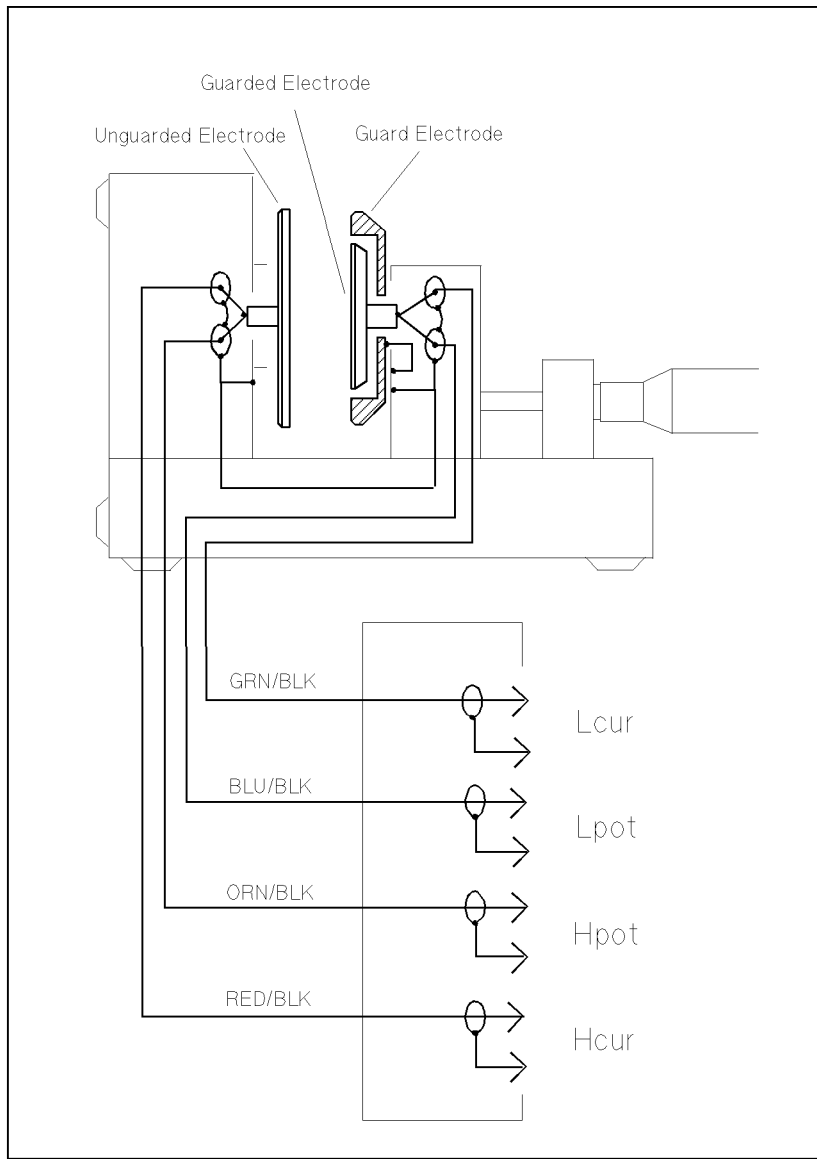

A6004003

Figure 4-4. Cable Connection Diagram

Manual Changes

Introduction

This appendix contains the information required to adapt this manual to earlier versions or configurations of the 16451B than the current printing date of this manual. The information in this manual applies directly to 16451B Dielectric Test Fixture whose serial number prefix is listed on the title page of this manual.

Manual Changes

To adapt this manual to your 16451B , refer to Table A-1, and make all of the manual changes listed opposite your fixture’s serial number.

Fixtures manufactured after the printing of this manual may be different than those documented in this manual. Later fixture versions will be documented in a manual changes supplement that will accompany the manual shipped with that fixture. If your fixture serial number is not listed on the title page of this manual or in Table A-1, it may be documented in a *yellow MANUAL CHANGES* supplement.

For additional information on serial number coverage, refer to “Serial Number” in Chapter 2.

Table A-1. Manual Changes by Serial Number

Serial Prefix or Number	Make Manual Changes
	There are no earlier configurations than the printing date of this manual.

Recommended Capacitance Range

This section shows the recommended capacitance range of test materials for using the 16451B with Electrode-A ($\phi 38$ mm electrode) or Electrode-B ($\phi 5$ mm electrode).

Using Electrode-A ($\phi 38$ mm electrode)

The area surrounded by bold lines in Figure B-1 shows the recommended capacitance range when using Electrode-A.

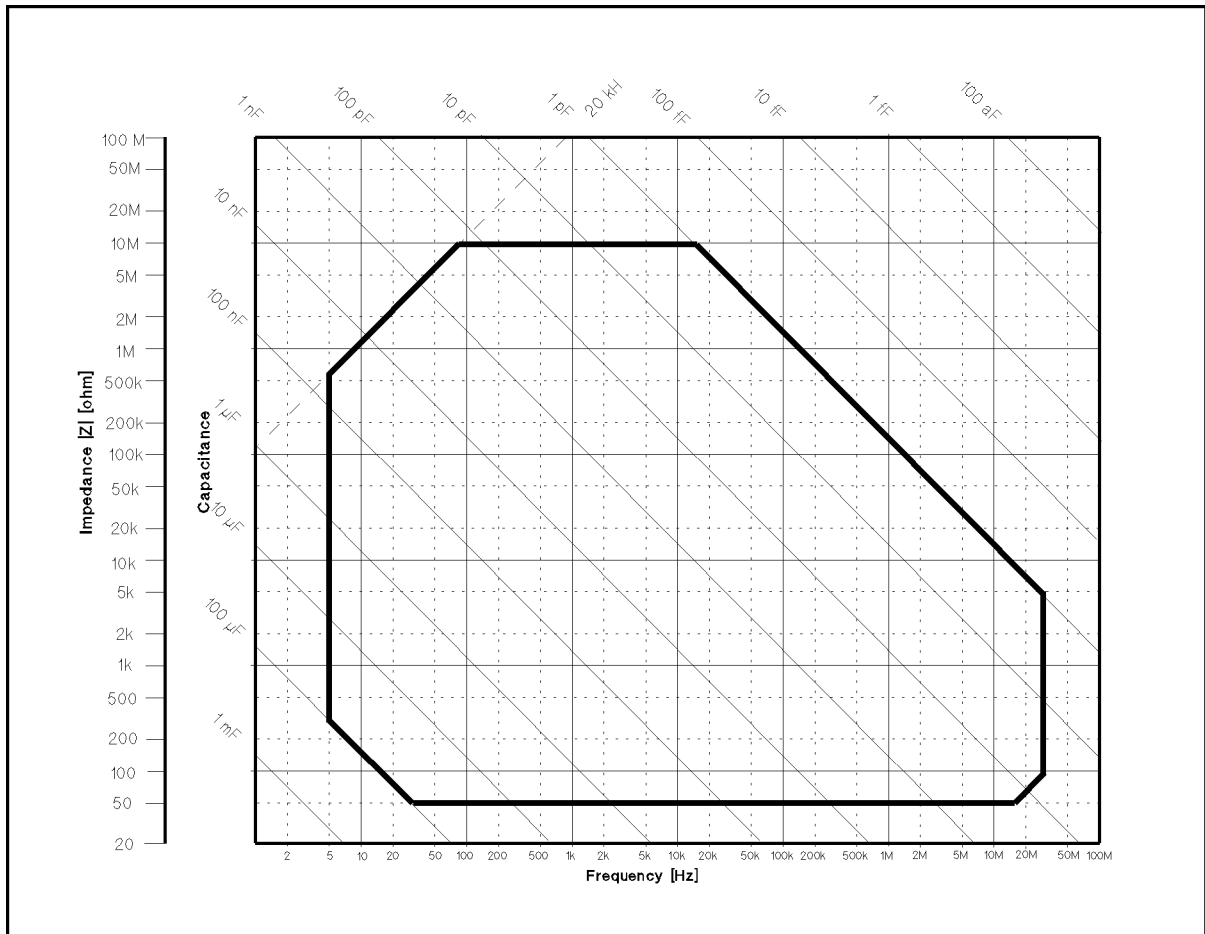

A60B001

Figure B-1. Recommended Capacitance Range Using Electrode-A

Using Electrode-C ($\phi 5$ mm electrode)

The area surrounded by bold lines in Figure B-2 shows the recommended capacitance range when using Electrode-B.

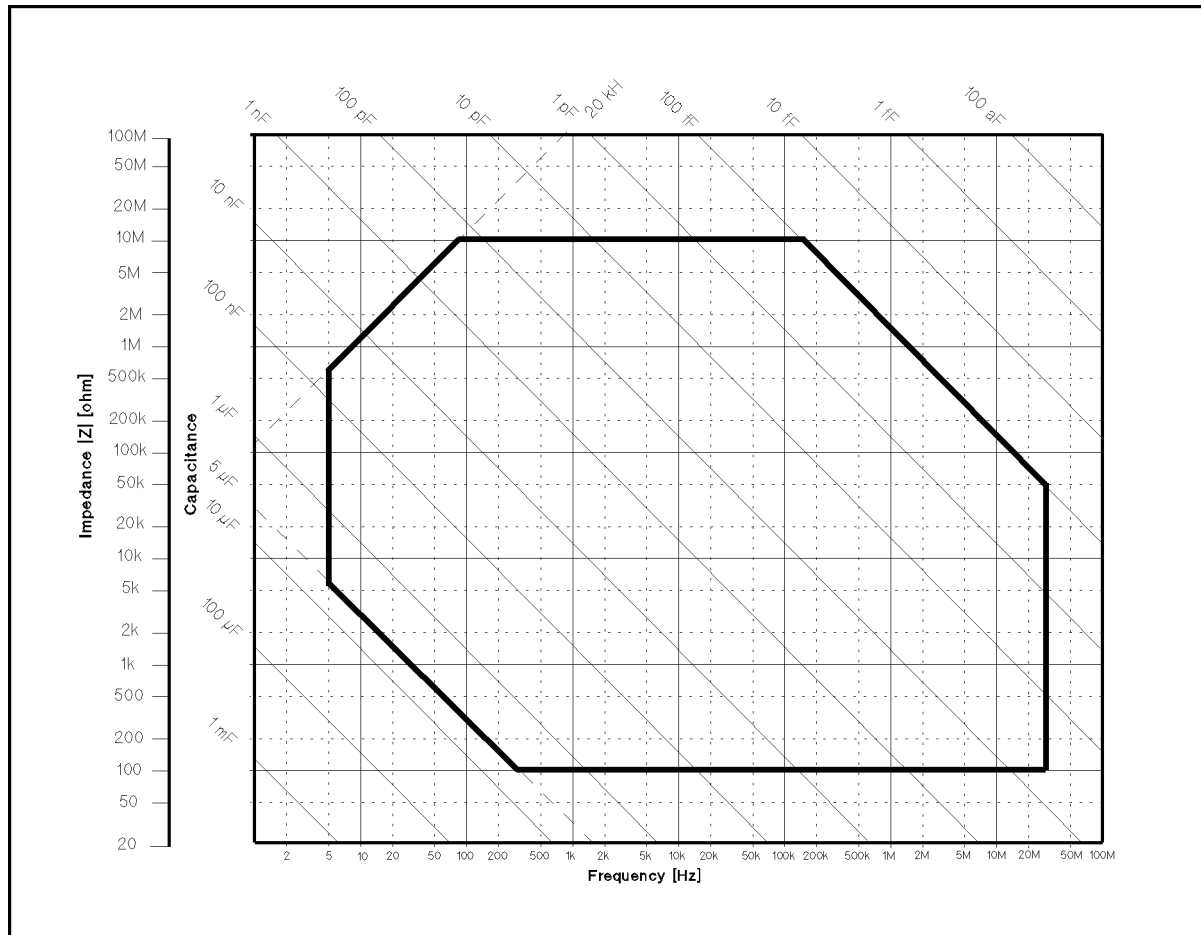

A60B002

Figure B-2. Recommended Capacitance Range Using Electrode-B

Correction Procedure

4192A

1. Connect the attachment without the cover to the Unguarded electrode of the 16451B.
2. Press **BLUE**, **SHORT**. The indicator lamp will come ON and R(resistance) and X(reactance) offset adjustments are automatically performed at the spot frequency displayed on DISPLAY C. CAL(calibration) is displayed on DISPLAY A and will remain ON until the offset adjustment is completed; a value of approximately zero will then be displayed.
3. Remove the attachment from the electrode.
4. Connect the attachment with the cover to the Guarded/Guard electrode.
5. Set the circuit mode to .
6. Press **BLUE**, **OPEN** then the indicator lamp will come ON and G(conductance) and B(susceptance) offset adjustments are automatically performed at the spot measuring frequency displayed on DISPLAY C. CAL(calibration) is displayed on DISPLAY A and will remain ON until the offset adjustment is completed; a value of approximately zero will then be displayed.
7. Remove the attachment from the electrodes and store it with the cover in the carrying case.

4194A

1. Connect the attachment with the cover to the Guarded/Guard electrode.
2. Press **COMPEN**, **ZERO OPEN**, **ENTER/EXECUTE** to start the OPEN offset measurement to collect data to be used for correction. The **Measuring zero open** message will be displayed for several seconds, then the **Zero open compen complete** message will appear. The measurement data will not be displayed.
3. Remove the attachment from the electrode.
4. Connect the attachment without the cover to the Unguarded electrode of the 16451B.
5. Press **COMPEN**, **ZERO SHORT**, **ENTER/EXECUTE** to start the SHORT offset measurement for correction. The message **Measuring zero short** will be displayed for several seconds, then **Zero short compen complete** will be displayed. Measurement data will not be displayed.
6. Press **OPEN OFS on/off**, **SHRT OFS on/off** to compensate measurements using previously acquired OPEN/SHORT-offset data.
7. Remove the attachment from the electrode and store it with the cover in the carrying case.

4274A and 4275A

Caution



Before proceeding with zero offset adjustment, verify that bias indicator lamp is not ON. If illuminated, set rear panel DC bias switch to OFF.

1. Connect the attachment with the cover to the Guarded/Guard electrode.
2. Press MULTIPLIER to $\times 5$ (for the 4274A or $\times 1$ (for the 4275A) and the OSC LEVEL control to its maximum output position, and set the other controls for the desired function, frequency, circuit mode, etc.
3. Press **ZERO OPEN** to start the OPEN offset measurement. This automatically sets the instrument to the C-G measurement mode. Display A exhibits CAL while stray capacitance and conductance values are being measured at each test frequency. The test frequency display is switched, in turn, to successively lower frequencies from 100 kHz. Lastly, all panel control functions are restored to the settings set in step 2 (about 10 seconds after pressing **OPEN**).
4. Remove the attachment from the electrode.
5. Connect the attachment without the cover to the Unguarded electrode of the 16451B.
6. Press **ZERO SHORT** to start the SHORT offset measurement. This automatically sets instrument to L-ESR measurement mode. A sequential measurement is performed with respect to residual inductance and resistance in the same manner as that in the ZERO OPEN offset adjustment operation (in step 3). The instrument is now ready to take measurements.
7. Remove the attachment from the electrodes and store it with the cover in the carrying case.

When the ZERO offset adjustments are performed in the high resolution mode (to measure small values with high accuracy), CAL is displayed for about 20 seconds.

4276A and 4277A

1. Connect the attachment with the cover to the Guarded/Guard electrode.
2. Press **ZERO OPEN** to start the OPEN Zero Offset Adjustment. When **ZERO OPEN** is pressed, the instrument will be automatically set to the C-G measurement mode. It will then measure the test fixture's stray admittance at each of the 9 preset frequency points. The measured values are stored in the instrument's internal memory. When offset adjustment is completed, DISPLAY A and DISPLAY B will be blank for 1 or 2 seconds, after which the front panel controls will be reset to the settings that existed when **ZERO OPEN** was pressed.
3. Remove the attachment from the electrode.
4. Connect the attachment without the cover to the Unguarded electrode of the 16451B.
5. Press **ZERO SHORT** to start the SHORT Zero Offset Adjustment. When **ZERO SHORT** is pressed, the instrument will be automatically set to the $|Z|-\theta$ (for the 4276A) or L-ESR (for the 4277A) measurement mode. It will then measure the test fixture's residual impedance at each of the 9 preset frequency points. The measured values are stored in the instrument's internal memory. When offset adjustment is completed, DISPLAY A and DISPLAY B will be blank for 1 or 2 seconds, after which the front panel controls will be reset to the settings that existed when **ZERO SHORT** was pressed.
6. Remove the attachment from the electrodes and store it with the cover in the carrying case.

4278A

1. Connect the attachment with the cover to the Guarded/Guard electrode.
2. Press **COMPEN**, **OPEN COMPEN** to start the OPEN offset measurement and observe the display. The message `Open offset compen. completed` will be displayed on the Message Line (the bottom line of the LCD), and the OPEN admittance data will be displayed on the Monitor Line (the second line from the bottom).
3. Press **TRIGGER** and confirm that the measurement result is the same (or almost the same) as the OPEN admittance data.
4. Press **OPEN ON**, then press **TRIGGER**. The measurement result is compensated for, in accordance with the OPEN admittance data, and is close to zero in value. Press **NEXT**.
5. Remove the attachment from the electrode.
6. Connect the attachment without the cover to the Unguarded electrode of the 16451B.
7. Press **SHORT COMPEN** to start the SHORT correction measurement, then the message `Short offset compen. completed` will be displayed on the Message Line, and the SHORT correction impedance data will be displayed on the Monitor Line.
8. Press **SHORT ON** and **return**.
9. Remove the attachment from the electrodes and store it with the cover in the carrying case.

4284A

The 4284A uses two kinds of OPEN/SHORT correction data as follows.

1. The OPEN/SHORT correction data which is taken at all preset frequency points independent of the test frequency you set, and the OPEN/SHORT correction data for each measurement point over the specified frequency points is calculated using the interpolation method.
2. The OPEN/SHORT correction data which is taken at the frequency points you specify allows you to set up to three frequency points in the *FREQ1*, *FREQ2*, and *FREQ3* fields.

Perform the following steps to execute the OPEN/SHORT correction at all frequency points using the interpolation method.

1. Connect the attachment with the cover to the Guarded/Guard electrode.
2. Press **MEAS SETUP** and move the cursor to the OPEN field.
3. Press **MEAS OPEN** to start measuring the OPEN admittance (capacitance and inductance) at the preset frequency points. The time required to measure the OPEN correction data is approximately 90 seconds. During the OPEN correction measurement, **ABORT** is available to stop the OPEN correction data measurement. The previous OPEN correction data will still be stored.
4. Press **OPEN ON** to perform the OPEN correction calculations on subsequent measurements using the OPEN interpolation correction data when the *FREQ1*, *FREQ2* and *FREQ3* fields are set to OFF.
When the *FREQ1*, *FREQ2* and *FREQ3* fields are set to ON, and the test frequency is equal to *FREQ1/2/3*, the OPEN correction data at *FREQ1/2/3* is used.
5. Remove the attachment from the electrode.
6. Connect the attachment without the cover to the Unguarded electrode of the 16451B.
7. Move the cursor to SHORT field. (If there is no SHORT field in the display, press **MEAS SETUP**, **CORRECTION**, then the SHORT field will be displayed.)
8. Press **MEAS SHORT** to measure the SHORT impedance (inductance and resistance) at the preset frequency points. The time required to measure the SHORT correction data is approximately 90 seconds. During the SHORT correction measurement, **ABORT** is available to stop the SHORT correction data measurement. The previous SHORT correction data will still be stored.
9. Press **SHORT ON** to perform the SHORT correction calculations on subsequent measurements using the SHORT interpolation correction data when the *FREQ1*, *FREQ2* and *FREQ3* fields are set to OFF.
When the *FREQ1*, *FREQ2* and *FREQ3* fields are set to ON, and the

test frequency is equal to $FREQ1/2/3$, the **SHORT** correction data at $FREQ1/2/3$ is used.

10. Remove the attachment from the electrodes and store it with the cover in the carrying case.

Perform the following steps to execute the **OPEN/SHORT** correction at the frequency points you want to specify.

1. Connect the attachment with the cover to the **Guarded/Guard** electrode.
2. Press **MEAS SETUP** and move the cursor to the **FREQ1, FREQ2 OR FREQ3** field.
3. Press **ON** to show the previous frequency for the **OPEN/SHORT/LOAD** correction.
4. Enter the frequency using the numeric entry keys. When pressing one of the numeric entry keys, the softkey labels are changed to the available units (Hz, kHz and MHz), so you can use these softkeys to enter the unit and terminate the entry without pressing **ENTER**. (When **ENTER** is used, the numeric data is entered with Hz.)
5. Press **MEAS OPEN**, to start performing an **OPEN** correction measurement at the frequency points you specified. After which, the **OPEN** correction measurement data are displayed on the system message line.
6. Move the cursor to the **OPEN** field.
7. Press **ON** to perform the **OPEN** correction calculations for subsequent measurements at the specified frequency points.
8. Remove the attachment from the electrode.
9. Connect the attachment without the cover to the **Unguarded** electrode of the 16451B.
10. Move the cursor to the **FREQ1, FREQ2 or FREQ3** field at which you specified the frequency.
11. Press the **MEAS SHORT** to perform a **SHORT** correction measurement and display the **SHORT** correction data on the system message line.
12. Move the cursor to the **SHORT** field.
13. Press **ON** to perform the **SHORT** correction calculations for subsequent measurements at the specified frequency points.
14. Move the cursor to the **LOAD** field.
15. Press **OFF** not to enable the **LOAD** correction. (If you want to use the **LOAD** calculation, please refer to the 4284A Operation Manual.)
16. Remove the attachment from the electrodes and store it with the cover in the carrying case.

Sample program

Sample ASP Program for the 4194A

This is a sample program to set up the 4194A, measure capacitance of a test material and obtain the dielectric constant using the 16451B with the 4194A. For more information on using the 4194A's ASP function, refer the *4194A Operation Manual*.

```

10 ! DIELECTRIC CONSTANT MEASUREMENT
20 !     USING 16451B
30 ! *****
40 RST                ! RESET 4194A
50 FNC1              ! MEAS. FUNCTION IMPEDANCE
60 IMP14             ! CP-D
40 SWT2              ! LOG SWEEP
50 START=1 KHZ      ! START FREQ. 1 KHZ
60 STOP=10 MHZ      ! STOP FREQ. 10 MHZ
70 ITM2              ! INTEG TIME MED
80 NOA=4             ! AVERAGE IS 4
90 DISP "PUT ATTACH. WITH COVER"
100 BEEP
110 PAUSE
120 ZOPEN            ! MEAS. OPEN
130 DISP "PUT ATTACH. WITHOUT COVER"
140 PAUSE
150 ZSHRT            ! MEAS. SHORT
160 OPN1             ! OPEN OFFSET ON
170 SHT1             ! SHORT OFFSET ON
180 PAUSE
190 SWTRG            ! START TRIGGER
200 AUTO             ! AUTO SCALE
210 PAUSE
220 A=A*9.96E9      ! CAL. DIELECTRIC CONSTANT
230 AUTO             ! AUTO SCALE
240 DPBO             ! DISP B OFF
250 END

```

Sample Program for the 4284A

This is a sample program for the HP 9000 series 300 Engineering Workstation to set up and measure a test material and obtain the dielectric constant using the 16451B with the 4284A via GPIB. For more information to use the 4284A such as GPIB command, refer the *4284A Operation Manual*.

```
1000 DIM Xp(20),Yp(20)
1010 DIM Work$(100)
1020 DIM Freq(20),A(2,20),B(2,20),D(20)
1030 DIM Axis(2,2),Axis$(2)[20]
1040 !
1050 Ix=1
1060 Iy=2
1070 Tg=2.5*10^(-3)           ! Distance of gap
1080 Ta=2.01*10^(-3)        ! Thickness of material
1090 Tr=Tg/Ta
1100 !
1110 Hp4284a=717             ! Address of 4284A
1120 ASSIGN @Work TO "WORK"
1130 READ Nfreq              ! read number of frequency
1140 !
1150 FOR Ifreq=1 TO Nfreq
1160   READ Freq(Ifreq)      ! read meas. frequency
1170 NEXT Ifreq
1180 !
1190 F_correct=0
1200 INPUT "Dose the correction required? (yes=1 no=0)",F_correct
1210 !
1220 ! * 4284A initialization *
1230 OUTPUT Hp4284a;"CORR:LENG 1M"      ! Cable length 1 m
1240 OUTPUT Hp4284a;"TRIG:SOUR BUS"    ! Bus trigger mode
1250 OUTPUT Hp4284a;"FUNC:IMP CSD"     ! Ls-Rs maes. func.
1260 OUTPUT Hp4284a;"INIT:CONT ON"
1270 OUTPUT Hp4284a;"DISP:PAGE MEAS"   ! Meas. page
1280 OUTPUT Hp4284a;"INIT"            ! Initialize
1290 ! * Correction *
1300 IF F_correct=No THEN Skip_correct
1310 PRINT "Put the Attachment for OPEN correction"
1320 PAUSE
1330 OUTPUT Hp4284a;"CORR:OPEN"        ! Execute OPEN
1340 OUTPUT Hp4284a;"STAT:OPER:EVEN?" ! Check meas. end
1350 ENTER Hp4284a;Event_reg
1360 IF BINAND(Event_reg,1)=0 THEN 1340
1370 PRINT "Change the Attachment for SHORT correction"
1380 PAUSE
1390 OUTPUT Hp4284a;"CORR:SHORT"       ! Execute SHORT
1400 OUTPUT Hp4284a;"STAT:OPER:EVEN?" ! Check meas. end
1410 ENTER Hp4284a;Event_reg
1420 IF BINAND(Event_reg,1)=0 THEN 1400
1430 Skip_correct:
1440 OUTPUT Hp4284a;"CORR:OPEN:STAT 1" ! OPEN ON
1450 OUTPUT Hp4284a;"CORR:SHORT:STAT 1"! SHORT ON
1460 ! * Meas. routine *
1470 FOR Imeas=1 TO 2
```

```

1480 IF Imeas=1 THEN PRINT "Remove the attachment, then press CONT."
1490 IF Imeas=2 THEN PRINT "Set test material on the electrode, then press
CONT."
1500 PAUSE
1510 FOR Ifreq=1 TO Nfreq
1520     OUTPUT Hp4284a;"FREQ "&VAL$(Freq(Ifreq))
1530     OUTPUT Hp4284a;"*TRG"
1540     ENTER Hp4284a;Work$
1550     A(Imeas,Ifreq)=VAL(Work$[1,12])
1560 NEXT Ifreq
1570 NEXT Imeas
1580 !
1590 PRINTER IS 701
1600 PRINT "Meas. Frequency      Dielectric Const."
1610 FOR Ifreq=1 TO Nfreq
1620     D(Ifreq)=1/(1-(1-A(1,Ifreq)/A(2,Ifreq))*Tr)
1630     PRINT USING "D.DDESZZ,AAAAAA,D.DDDD"; Freq(Ifreq) ; "[Hz]"; D(Ifreq)
1640 NEXT Ifreq
1650 PRINTER IS CRT
1660 !
1670 OUTPUT @Work;Nfreq                ! Store meas. condition
1680 FOR Ifreq=1 TO Nfreq
1690     OUTPUT @Work;D(Ifreq)         ! Store meas. data
1700 NEXT Ifreq
1710 ! * Graphic initialize *
1720 CLEAR SCREEN                    ! Clear screen
1730 WINDOW -.5,2,-.5,2              ! Set graphic window
1740 Dmax=MAX(D(*))                  ! Find max. value of meas. dat
1750 GOSUB Axis
1760 FOR Ifreq=1 TO Nfreq            ! * Calc. graphic data *
1770 !
1780     Xp(Ifreq)=Freq(Ifreq)/Freq(Nfreq)
1790     Yp(Ifreq)=D(Ifreq)/Dmax
1800 !
1810 NEXT Ifreq
1820 MOVE Xp(1),Yp(1)
1830 FOR Ifreq=1 TO Nfreq
1840     DRAW Xp(Ifreq),Yp(Ifreq)
1850 NEXT Ifreq
1860 STOP
1870 !
1880 Axis:
1890 Axis$(1)="FREQ."
1900 Axis$(2)="Dielectric Constant"
1910 MAT Axis= (0)
1920 FOR Iax=1 TO 2
1930     Axis(Iax,Iax)=1.2
1940 NEXT Iax
1950 Xzero=0
1960 Yzero=0
1970 FOR Iax=Ix TO Iy
1980     MOVE Xzero,Yzero
1990     DRAW Axis(Iax,Ix),Axis(Iax,Iy)
2000     IF Iax=Ix THEN MOVE Axis(Iax,Ix)/2,Yzero-.1
2010     IF Iax=Iy THEN MOVE Xzero-.1,Axis(Iax,Iy)/2

```

```

2020     IF Iax=Ix THEN LORG 6
2030     IF Iax=Iy THEN LORG 4
2040     IF Iax=Iy THEN LDIR PI/2
2050     LABEL Axis$(Iax)
2060 NEXT Iax
2070 LDIR 0
2080 LORG 8
2090 MOVE .05,2/Dmax
2100 DRAW Xzero,2/Dmax
2110 LABEL "2"
2120 MOVE Xzero,Yzero
2130 LABEL "0"
2140 !
2150 LORG 6
2160 MOVE 1,.05
2170 DRAW 1,Yzero
2180 LABEL "1 M"
2190 RETURN
2200 ! * Meas. freq. data *
2210 DATA 10                               ! Number of data
2220 DATA 1E4,2E4,5E4,1E5,2E5,3E5,4E5,5E5,7E5,1E6
2230 END

```

Bibliography

ASTM Standards:D150-81, “*Standard Test Method for A-C Loss Characteristics and Permittivity (Dielectric Constant) of Solid Electrical Insulating Materials*”, *Annual Book of ASTM Standards*, Vol 10.02, July, 1987, pp.21-44.

Index

- 3** 3-terminal, 3-1

- 4** 4192A, 1-4
4194A, 1-4
ASP, 3-53
measurement example, 3-52
4263B, 1-4
4268A, 1-4
4278A, 1-4
4279A, 1-4
4284A, 1-4
LOAD correction, 3-35
measurement example, 3-52
program, 3-56
4285A, 1-4
4294A, 1-4
4-terminal pair, 1-1, 3-1, 3-28

- 9** 9000 series 300, 3-56

- A** A, 3-6, 3-12, 3-17, 3-48
accessory, **2-3**, 3-4
Accuracy, **2-4**
accurate adjustment, 3-36, 3-40
address, ii, vii
adjuster, 3-3
adjustment
accurate, 3-36, 3-40
capacitance limit, 3-41
electrode, 3-36
Non-contacting Electrode method, 3-42
parallel, 3-36
rough, 3-36, 3-38
vertical position, 3-40
adjustment knob, 3-3
adjustment screw, 3-3
air film, 3-11, 3-27
Air Gap method, 3-9, 3-21
measurement example, 3-55
principle, 3-21
alcohol, 3-28
 α , 3-59
 α_a , 3-59
 α_b , 3-59

- angle, 4-3
- Applicable voltage range, **2-3**
- area
 - effective area, 3-59
- ASP, 3-53
- assembly, 4-1
- Assistance, vii
- ASTM, E-1
- ASTM standards D150, 3-27
- Attachment, 1-2
- attachment for error correction, 3-5
- attachment screw, 3-3, 3-28
- average, 3-26

B

- B_a, 3-59
- base, 4-5
- basic
 - theory, 3-6
- BASIC program, 3-56
- B_b, 3-59
- bias, 3-1
- Bold, vi
- bumper foot, 4-4
- bushing, 4-5

C

- cable assembly, 3-1, 3-3, 4-4, 4-5, 4-6
- cable compensation, 1-4
- cable connection diagram, 4-9
- Cable Length, **2-3**
- cable length switch, 3-28
- capacitance, 3-6
- capacitance limit, 3-41
- capacitance measurement error, 3-57, 3-62
- carrying case, 3-5
- Carrying Case, 1-2
- Caution, **iv**
- CAUTION, 1-1
- ccw, 3-28
- changing electrode, 3-28
- characteristics, 2-4
- C_m, 3-63
- compatible instrument, 1-4
 - error correction, 1-4
- compensation, 1-4
- compensation result example, 3-64
- Computer, vi
- conductive paint, 3-27
- connecting, 3-28
- Contacting Electrode method
 - measurement example, 3-52
 - procedure, 3-45
- Contacting Electrode method (Rigid Metal electrode principle, 3-11
- Contacting Electrode method (Thin Film electrode

- principle, 3-16
- contents, 1-2
- copyright, ii
- correction, 1-4, 3-30
 - for Electrode-A, 3-32
 - for Electrode-B, 3-32
 - for Electrode-C, 3-34
 - for Electrode-D, 3-34
 - for Rigid Metal electrode, 3-32
 - for Thin Film electrode, 3-34
- LOAD, 3-35
- OPEN, 3-30
- SHORT, 3-32
- correction function, 1-4
- cover, 3-5, 4-3
- cover bottom, 4-4
- cover top, 4-4
- C_p , 3-6, 3-12, 3-17, 3-48
- C_s , 3-50
- C_{s1} , 3-22
- C_{s2} , 3-22, 3-50
- cw, 3-30

D

- d, 3-6, 3-12, 3-17
- D, 3-12, 3-17, 3-48
- D_1 , 3-22, 3-50
- D150, E-1
- D_2 , 3-22, 3-50
- dc bias, 3-1
- demerit
 - Non-contacting Electrode method, 3-21
 - Rigid Metal, 3-11
 - Thin Film, 3-16
- dent, 1-2
- Description, 1-1
- diameter, 2-9, 3-26
 - Electrode-A, 3-14, 3-24
 - Electrode-B, 3-15, 3-25
 - Electrode-C, 3-19
 - Electrode-D, 3-20
 - test material, 3-14, 3-15, 3-19, 3-20, 3-24, 3-25
 - tolerance, 3-58
- dielectric, 3-6
- dielectric constant, 2-1
 - relative dielectric constant, 2-1
- dimensions, 2-9, 2-10
- Dimensions, 2-7
- disassembly, 4-1
- dissipation factor, 3-7
- D_r , 3-7
- D_t , 3-12, 3-17, 3-22, 3-48, 3-57

- E**
 - edge, 3-8
 - effective area
 - table, 3-60
 - using Contacting Electrode method, 3-59
 - using Non-contacting Electrode method, 3-64
 - electrical trouble, 4-8
 - electric force, 3-8
 - electrode
 - 38 mm Guarded/Guard electrode, 3-14
 - 38 mm Guarded/Guard Electrode, 3-24
 - 5 mm Guarded/Guard electrode, 3-15
 - 5 mm Guarded/Guard Electrode, 3-25
 - adjustment, 3-36
 - changing, 3-28
 - diameter, 3-15, 3-19, 3-20, 3-24, 3-25
 - Diameter, 3-14
 - Electrode-A, 3-5, 3-14, 3-24
 - Electrode-B, 3-5, 3-15, 3-25
 - Electrode-C, 3-5, 3-19, 3-20
 - Electrode-D, 3-5
 - for Air Gap method, 3-23
 - for Contacting Electrode method, 3-18
 - for large thin film electrode, 3-19
 - for Non-contacting electrode, 3-23
 - for small thin film electrode, 3-20
 - for Thin Film electrode, 3-18
 - part number, 4-7
 - Thin Film electrode, 3-16
 - tolerance of diameter, 3-58
 - Electrode
 - Electrode-A, 1-2
 - Electrode-B, 1-2
 - Electrode-C, 1-2
 - Electrode-D, 1-2
 - for Contacting electrode method, 3-13
 - Rigid Metal electrode, 3-13
 - Unguarded electrode, 1-2
 - environment, iv
 - environmental limitations, 2-11
 - ϵ , 3-6
 - ϵ_o , 3-6, 3-12, 3-17, 3-48
 - ϵ_r , 3-6, 3-12, 3-17, 3-22, 3-48, 3-57
 - equation, 3-6, 3-53, 3-56
 - Contacting Electrode method, 3-48
 - Contacting Electrode method (Rigid Metal), 3-12
 - Contacting Electrode method (Thin Film electrode), 3-17
 - Non-contacting Electrode method, 3-50
 - equivalent distance, 3-62
 - equivalent distance error, 3-62
 - Errata, 2-2
 - error
 - capacitance measurement error, 3-57, 3-62
 - compensation result example, 3-64
 - diameter, 3-58
 - effective area, 3-59, 3-64

- equivalent distance, 3-62
- error analysis, 3-57
- error factor, 3-57
- flatness, 3-58, 3-62
- flatness error, 3-27
- gap, 3-58, 3-62
- measurement error, 3-57
- micrometer, 3-58, 3-62
- parallelism, 3-58, 3-62
- reduce gap error, 3-62
- thickness, 3-58, 3-62
- tolerance, 3-58
- using Contacting Electrode method, 3-57
- using Non-contacting Electrode method, 3-62
- error correction, 3-30
- evaporated metal, 3-27
- example, 3-52
 - 4194A, 3-52
 - 4284A, 3-55
 - Air Gap method, 3-55
 - Contacting Electrode method, 3-52
 - Non-contacting Electrode method, 3-55
 - Rigid Metal electrode, 3-55
 - Thin Film electrode, 3-52
- Exclusive Remedies, vi

F

- film, 3-26
- fired on silver, 3-27
- fixture assembly, 2-10, 3-1
- flatness
 - error, 3-58, 3-62
 - preparation, 3-27
- for Contacting Electrode method, 3-9
- for Non-contacting Electrode method, 3-9
- frequency range, **2-3**
 - compatible instrument, 1-4
- function, **2-3**
- furnished accessory, 3-4

G

- g, 3-59
- gap
 - between Guarded electrode and Guard electrode, 3-19, 3-20, 3-27
 - between Guarded/Guard electrode and Unguarded electrode, 3-58, 3-62
 - error, 3-58, 3-62
- General Information, 2-1
- glove, 3-28
- GPIB, 3-56
- Guarded/Guard electrode, 3-1, 3-3
- Guard electrode, 3-8

- H**
 - Hardkey, vi
 - He, 3-3
 - hex key, 3-5
 - Hex key, 1-2
 - Hp, 3-3
 - humidity, 2-11
 - Humidity, **2-3**

- I**
 - IEC, 2-1
 - impedance analyzer, 1-1
 - incoming inspection, 1-1
 - Initial inspection, 1-2
 - Installation, 1-1
 - Introduction, 1-1
 - instrument
 - compatible, 1-4
 - compatible instrument, 1-4
 - frequency range, 1-4
 - insulator, 4-3
 - Italics, vi

- L**
 - large knob, 3-3
 - Lc, 3-3
 - LCR meter, 1-1
 - limit
 - for adjustment, 3-41
 - lint free, 3-28
 - LOAD, 1-4
 - compensation, 3-35
 - correction, 3-35
 - loss tangent, 3-7
 - Lp, 3-3

- M**
 - Manual
 - How to use, v
 - part number, iii
 - printing history, iii
 - Manual Change, 2-2
 - material, 2-9
 - measurement, 3-6
 - example, 3-52
 - method, 3-9
 - procedure, 3-45
 - mechanical trouble, 4-8
 - merit
 - Non-contacting Electrode method, 3-21
 - Rigid Metal, 3-11
 - Thin Film, 3-16
 - metal foil, 3-27
 - metal spattering, 3-27
 - method, **3-9**
 - Air Gap method, 3-21
 - error using Contacting Electrode method, 3-57

- error using Non-contacting Electrode method, 3-62
- Non-contacting Electrode method, 3-21
 - procedure, 3-45
- micrometer, 2-9, 3-1, 3-3, 4-3
 - error, 3-58, 3-62
 - replacement, 4-2
 - stand replacement, 4-2
- missing contents, 1-2

N negative D, 3-35
Non-contacting Electrode method, 3-21

- adjustment, 3-42
- measurement example, 3-55
- principle, 3-21
- procedure, 3-49

Note, **iv**
NOTE, 1-1
Notice, **ii**

O offset, 3-30, 3-32
OPEN, 1-4, 3-30
OPEN circuit, 3-30
OPEN/SHORT/LOAD, 1-4
operation, 3-1
operation check, 4-8
overview, 1-2, **3-1**

P packaging, 2-11
parallel

- adjustment, 3-36

parallelism

- error, 3-58, 3-62

part number, 1-2
performance, 2-3, 2-4
permittivity, 2-1
physical damage, 1-2
plate, 3-26, 4-3
plug hole, 4-5
preparation, **3-26**
preparing, 1-1
pressure adjuster, 3-3
principle

- Contacting Electrode method (Rigid Metal electrode), 3-11
- Contacting Electrode method (Thin Film electrode), 3-16
- Non-contacting Electrode method (Air Gap method), 3-21

procedure, 3-45

- Contacting Electrode method, 3-45, 3-46
- Non-contacting Electrode method, 3-49

program, 3-53

- Q** quantity, 1-2

- R** Range, 2-4
 - ratchet knob, 3-3
 - relative dielectric constant, 2-1
 - repacking, 2-11
 - repair, vi, 1-2
 - replaceable parts list, 4-3
 - replacement, 1-2, 4-1
 - residual impedance, 3-30
 - resolution, 2-9
 - Rigid Metal electrode, 3-9
 - measurement example, 3-55
 - principle:, 3-11
 - rod, 4-5
 - rough adjustment, 3-36, 3-38

- S** Safety
 - summary, iv
 - symbol, iv
- Safety Consideration, 2-1
- scratch, 1-2
- screw, 3-3, 3-28, 4-3, 4-4, 4-5, 4-6
- Serial Number, 2-2
 - plate, 2-2
- service, 4-1
- shape
 - preparation, 3-26
- SHORT, 1-4, 3-32
- SHORT circuit, 3-32, 3-34
- SHORT correction
 - for Rigid Metal electrode, 3-32
 - for thin film electrode, 3-34
- slide stand, 4-1
- slide stand assembly, 4-6
- slightly compressible, 3-11
- small knob, 3-3
- smooth, 3-11
- Softkey, vi
- soft material, 3-21
- spacer, 4-5, 4-6
- Specifications, 2-3
- sprayed metal, 3-27
- spring, 4-5
- standards, E-1
- stopper, 4-4
- storage, 2-11
- stray admittance, 3-30
- stray capacitance, 3-8
- Supplemental Performance Characteristics, 2-4
- surface, 3-27

T

- t, 3-6, 3-22, 3-59
- t_a , 3-12, 3-17, 3-22, 3-48, 3-50
- $\tan\delta$, 3-7
- temperature, 2-11
- Temperature, **2-3**
- Test Fixture, 1-2
- test material
 - diameter, 3-14, 3-15, 3-19, 3-20, 3-24, 3-25, 3-26
 - flatness, 3-27
 - for Electrode-A, 3-14, 3-24
 - for Electrode-B, 3-25
 - for Electrode-C, 3-19
 - for Electrode-D, 3-20
 - gap, 3-19, 3-20
 - preparation, 3-26
 - shape, 3-26
 - size for Electrode-B, 3-15
 - surface, 3-27
 - thickness, 3-14, 3-15, 3-19, 3-20, 3-24, 3-25, 3-26
- Test Material, 2-9
- test signal level, 3-1
- t_g , 3-50
- theory, 3-6
- thick, 3-11
- thickness, 2-9
 - error, 3-58, 3-62
 - preparation, 3-26
 - test material, 3-14, 3-15, 3-19, 3-20, 3-24, 3-25
- thin film, 3-5
- Thin Film electrode, 3-9, 3-16
 - conductive paint, 3-27
 - evaporated metal, 3-27
 - fired on silver, 3-27
 - measurement example, 3-52
 - metal foil, 3-27
 - metal spattering, 3-27
 - preparation, 3-27
 - principle, 3-16
 - sprayed metal, 3-27
 - type, 3-27
- tolerance, 3-58
- trouble
 - electrical trouble, 4-8
 - mechanical trouble, 4-8
- troubleshooting, 4-1, 4-8
- t_{set} , 3-63
- Typeface, vi
- typical measurement, 3-45

- U** Δt_a , 3-63
 Δt_e , 3-63
Unguarded electrode, 3-3, 4-3

- V** vertical position
 adjustment, 3-40
 capacitance limit, 3-41
visual inspection, 3-36

- W** Warning, iv, iv
WARNING, 1-1
Warranty, vi
 limitation, vi
washer, 4-3, 4-4, 4-6
Weight, **2-3**
working standard, 3-35

- Z** ZERO OPEN offset, 3-30
ZERO SHORT offset, 3-32

REGIONAL SALES AND SUPPORT OFFICES

For more information about Agilent Technologies test and measurement products, applications, services, and for a current sales office listing, visit our web site: <http://www.agilent.com/find/tmdir>. You can also contact one of the following centers and ask for a test and measurement sales representative. 21/01/2004

United States:

Test and Measurement Call Center
(tel) 1 800 452-4844
(fax) 1 888 900-8921

Australia/New Zealand:

(tel) (61 3) 9210-5555 (Australia)
(fax) (61 3) 9210-5899
(tel) (64 4) 939-0636 (New Zealand)
(fax) (64 4) 972-5364

Canada:

Test and Measurement Call Center
(tel) 1 877 894-4414
(fax) 1 888 900-8921

Asia Pacific:

(tel) (65) 6375-8100
(fax) (65) 6836-0252
Email: tm_asia@agilent.com

China:

(tel) 800 810-0189
(fax) 800 820-2816

Europe:

(tel) (31 20) 547-2323
(fax) (31 20) 547-2390

Japan:

Call Center
(tel) 0120 421-345
(tel) (81) 426 56-7832
(fax) (81) 426 56-7840

Korea:

(tel) (82 2) 2004-5004
(fax) (82 2) 2004-5115

Latin America:

(tel) (305) 269-7500
(fax) (305) 269-7599

Taiwan:

(tel) 0800 047 866
(fax) 0800 286 331