ADVANTEST[®]
ADVANTEST CORPORATION

U3661

Spectrum Analyzer

Maintenance Manual

MANUAL NUMBER FME-8339628A00

Safety Summary

To ensure thorough understanding of all functions and to ensure efficient use of this instrument, please read the manual carefully before using. Note that Advantest bears absolutely no responsibility for the result of operations caused due to incorrect or inappropriate use of this instrument.

If the equipment is used in a manner not specified by Advantest, the protection provided by the equipment may be impaired.

- **Warning Labels**

Warning labels are applied to Advantest products in locations where specific dangers exist. Pay careful attention to these labels during handling. Do not remove or tear these labels. If you have any questions regarding warning labels, please ask your nearest Advantest dealer. Our address and phone number are listed at the end of this manual.

Symbols of those warning labels are shown below together with their meaning.

DANGER: Indicates an imminently hazardous situation which will result in death or serious personal injury.

WARNING: Indicates a potentially hazardous situation which will result in death or serious personal injury.

CAUTION: Indicates a potentially hazardous situation which will result in personal injury or a damage to property including the product.

- **Basic Precautions**

Please observe the following precautions to prevent fire, burn, electric shock, and personal injury.

- Use a power cable rated for the voltage in question. Be sure however to use a power cable conforming to safety standards of your nation when using a product overseas.
- When inserting the plug into the electrical outlet, first turn the power switch OFF and then insert the plug as far as it will go.
- When removing the plug from the electrical outlet, first turn the power switch OFF and then pull it out by gripping the plug. Do not pull on the power cable itself. Make sure your hands are dry at this time.
- Before turning on the power, be sure to check that the supply voltage matches the voltage requirements of the instrument.
- Be sure to plug the power cable into an electrical outlet which has a safety ground terminal. Grounding will be defeated if you use an extension cord which does not include a safety ground terminal.
- Be sure to use fuses rated for the voltage in question.
- Do not use this instrument with the case open.

Safety Summary

- Do not place objects on top of this product. Also, do not place flower pots or other containers containing liquid such as chemicals near this product.
- When the product has ventilation outlets, do not stick or drop metal or easily flammable objects into the ventilation outlets.
- When using the product on a cart, fix it with belts to avoid its drop.
- When connecting the product to peripheral equipment, turn the power off.

- **Caution Symbols Used Within this Manual**

Symbols indicating items requiring caution which are used in this manual are shown below together with their meaning.

DANGER: Indicates an item where there is a danger of serious personal injury (death or serious injury).

WARNING: Indicates an item relating to personal safety or health.

CAUTION: Indicates an item relating to possible damage to the product or instrument or relating to a restriction on operation.

- **Safety Marks on the Product**

The following safety marks can be found on Advantest products.

 : ATTENTION - Refer to manual.

 : Protective ground (earth) terminal.

 : DANGER - High voltage.

 : CAUTION - Risk of electric shock.

- **Replacing Parts with Limited Life**

The following parts used in the instrument are main parts with limited life.

Replace the parts listed below after their expected lifespan has expired.

Note that the estimated lifespan for the parts listed below may be shortened by factors such as the environment where the instrument is stored or used, and how often the instrument is used.

There is a possibility that each product uses different parts with limited life. For more information, refer to Chapter 1.

Main Parts with Limited Life

Part name	Life
Unit power supply	5 years
Fan motor	5 years
Electrolytic capacitor	5 years
LCD panel	6 years
LCD backlight	2.5 years
Floppy disk drive	5 years

- **Precautions when Disposing of this Instrument**

When disposing of harmful substances, be sure dispose of them properly with abiding by the state-provided law.

Harmful substances: (1) PCB (polycarbon biphenyl)
 (2) Mercury
 (3) Ni-Cd (nickel cadmium)
 (4) Other

Items possessing cyan, organic phosphorous and hexadic chromium and items which may leak cadmium or arsenic (excluding lead in solder).

Example: fluorescent tubes, batteries

Environmental Conditions

This instrument should be only be used in an area which satisfies the following conditions:

- An area free from corrosive gas
- An area away from direct sunlight
- A dust-free area
- An area free from vibrations

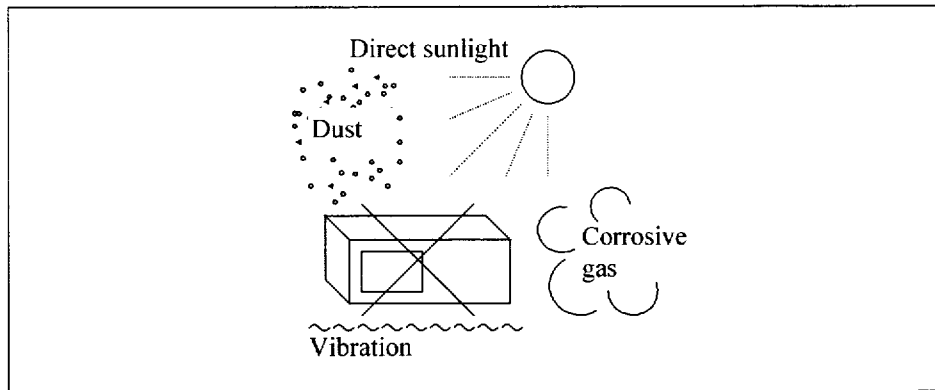

Figure-1 Environmental Conditions

- Instrument Placement

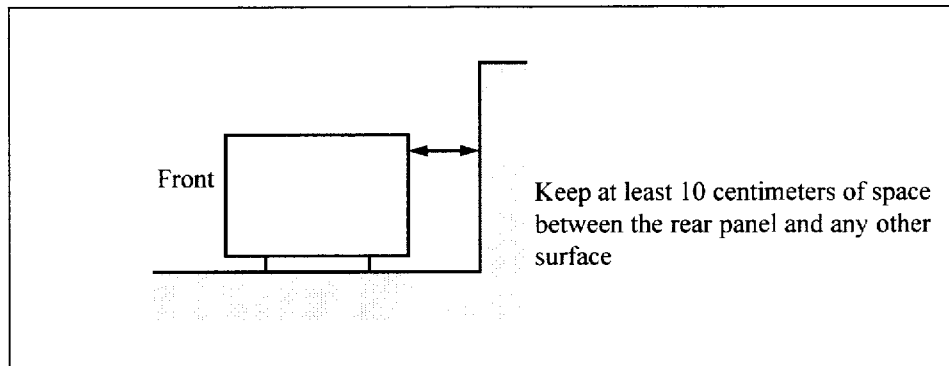

Figure-2 Instrument Placement

This instrument can be used safely under the following conditions:

- Altitude of up to 2000 m
- Installation Categories II
- Pollution Degree 2

TABLE OF CONTENTS

1.	GENERAL INFORMATION	1-1 of 10
	1.1. Introduction	1-1 of 10
	1.2. Outline of Product	1-2 of 10
	1.3. Specification	1-3 of 10
	1.4. Service Concept	1-9 of 10
	1.5. Test Equipment Required for Performance Verification Test	1-9 of 10
2.	THEORY OF OPERATION	2-1 of 4
	2.1. Introduction	2-2 of 4
	2.2. Over All Theory of Operation	2-2 of 4
	2.3. RF Block	2-2 of 4
	2.4. IF Block	2-2 of 4
	2.5. LOG Block	2-3 of 4
	2.6. A/D Block	2-3 of 4
	2.7. SYNTHESIZER Block	2-3 of 4
	2.8. DC/DC Block	2-3 of 4
	2.9. DC/DC-2 Block	2-3 of 4
	2.10. CPU Block	2-3 of 4
	2.11. FRONT Block	2-3 of 4
	2.12. TG Block	2-4 of 4
3.	PERFORMANCE VERIFICATION	3-1 of 72
	3.1. GENERAL	3-1 of 72
	3.2 PERFORMANCE VERIFICATION PROCEDURE	3-4 of 72
	3.2.1. 10 MHz Reference Output Accuracy	3-4 of 72
	3.2.2. Calibration Signal Output Amplitude Accuracy	3-5 of 72
	3.2.3. Displayed Average Noise Level	3-7 of 72
	3.2.4. Resolution Bandwidth Switching Uncertainty	3-11 of 72
	3.2.5. Resolution Bandwidth Accuracy and Selectivity	3-13 of 72
	3.2.6. IF Gain Uncertainty	3-16 of 72
	3.2.7. Input Attenuator Switching Accuracy	3-19 of 72
	3.2.8. Scale Fidelity	3-22 of 72
	3.2.9. Residual FM	3-27 of 72
	3.2.10. Noise Sidebands	3-31 of 72
	3.2.11. Image, Multiple, and Out-of-Band Responses	3-33 of 72
	3.2.12. Accuracy of Frequency Readout and Frequency Count Marker	3-35 of 72
	3.2.13. Second Harmonic Distortion	3-38 of 72
	3.2.14. Frequency Response	3-42 of 72
	3.2.15. Frequency Span Accuracy	3-46 of 72
	3.2.16. Third Order Intermodulation Distortion	3-49 of 72
	3.2.17. Gain Compression	3-52 of 72
	3.2.18. Sweep Time Accuracy	3-56 of 72
	3.2.19. Residual Response	3-58 of 72
	3.3 Tracking Generator Performance Verification Procedure (Optional)	3-62 of 72
	3.3.1. Absolute Output Level Accuracy	3-62 of 72
	3.3.2. Output Level Flatness	3-63 of 72
	3.3.3. Output Level Switching Accuracy	3-65 of 72

3.3.4. Harmonic Distortion	3-67 of 72
3.3.5. Non-harmonic Distortion.	3-69 of 72
3.3.6. TG Leakage	3-70 of 72
3.4. Performance Verification Test Record Sheet	3-72 of 72
4. ADJUSTMENT PROCEDURE	4-1 of 2
4.1. 10 MHz Reference Oscillator Adjustment	4-1 of 2
5. TROUBLESHOOTING	5-1 of 8
5.1. Preparation	5-1 of 8
5.1.1. Introduction	5-1 of 8
5.1.2. General Caution for Handling Replaceable Assemblies	5-1 of 8
5.2. Isolation of Failure Block	5-2 of 8
5.2.1. Introduction	
5.2.2. Isolation of Failure Block	
5.3. Procedure of Removal and Installation	5-4 of 8
5.3.1. Introduction	5-4 of 8
5.3.2. Tools Required	5-4 of 8
5.3.3. RF Block Removal and Installation	5-4 of 8
5.3.4. IF Block and LOG Block Removal and Installation	5-6 of 8
5.3.5. SYNTH Block, A/D Block, DC/DC-2 Block CPU Block and DC/DC Block Removal and Installation Procedure	5-8 of 8
5.3.6. TG Block Removal and Installation Procedure	5-8 of 8
6. REPLACEABLE PARTS	6-1 of 1
6.1. Introduction	6-1 of 1
6.2. Ordering Information	6-1 of 1
6.3. Replaceable Parts List	6-1 of 1

LIST OF ILLUSTRATION

Figure 2-1	Simplified Block Diagram of U3661	-----	2- 1 of 4
Figure 3-1	Setup of Frequency Reference Output Accuracy Test	-----	3-4 of 72
Figure 3-2	Setup of CAL OUT Level Accuracy Test	-----	3-6 of 72
Figure 3-3	Setup of Displayed Average Noise Level Test	-----	3-8 of 72
Figure 3-4	Setup of RBW Switching Uncertainty Test	-----	3-11 of 72
Figure 3-5	Setup of RBW Accuracy Test	-----	3-14 of 72
Figure 3-6	Setup of RBW Selectivity Test	-----	3-15 of 72
Figure 3-7	Setup of IF Gain Uncertainty Test	-----	3-17 of 72
Figure 3-8	Setup of Input Attenuator Switching Accuracy Test	-----	3-20 of 72
Figure 3-9	Setup for Scale Fidelity Test	-----	3-23 of 72
Figure 3-10	Setup of Residual FM Test	-----	3-28 of 72
Figure 3-11	Setup of Noise Sidebands Test	-----	3-31 of 72
Figure 3-12	Setup of a Image, Multiple, Out of Band Responses Test	-----	3-33 of 72
Figure 3-13	Setup of a Frequency Readout Accuracy and Frequency Counter Marker Test	-----	3-36 of 72
Figure 3-14	Setup of a Second Harmonics Distortion Test	-----	3-39 of 72
Figure 3-15	Setup of Frequency Response Test	-----	3-43 of 72
Figure 3-16	Setup of a Frequency Span Accuracy Test	-----	3-47 of 72
Figure 3-17	Setup of Third Order Intermodulation Test	-----	3-50 of 72
Figure 3-18	Setup of a Gain Compression Test	-----	3-53 of 72
Figure 3-19	Setup of a Sweep Time Accuracy Test	-----	3-57 of 72
Figure 3-20	Setup of Residual Response Test	-----	3-59 of 72
Figure 3-21	Setup of Absolute Output Level Accuracy Test	-----	3-62 of 72
Figure 3-22	Setup of Output Level Flatness Test.	-----	3-64 of 72
Figure 3-23	Setup of Output Switching Accuracy Test	-----	3-66 of 72
Figure 3-24	Setup of Harmonic Distortion Test	-----	3-68 of 72
Figure 3-25	Setup of Non-Harmonic Distortion Test	-----	3-70 of 72
Figure 3-26	Setup of TG Leakage Test	-----	3-71 of 72
Figure 4-1	Setup of Frequency Reference Adjustment	-----	4-1 of 2
Figure 4-2	Location of Potentiometer	-----	4-2 of 2
Figure 5-1	Location of Screw	-----	5-5 of 8
Figure 5-2	Location of Screw	-----	5-5 of 8
Figure 5-3	Removal of Front Panel Block	-----	5-6 of 8
Figure 5-4	Location of Screw on the bottom	-----	5-6 of 8
Figure 5-5	Location of Screw on the Rear Panel	-----	5-6 of 8
Figure 5-6	Locations of Blocks	-----	5-7 of 8
Figure 5-7	Removing RF Block	-----	5-7 of 8
Figure 5-8	Locations of Screws	-----	5-8 of 8

LIST OF TABLES

Table 1-1	Test Equipment for Performance Verification Test	-----	1-10 of 10
Table 3-1	Performance Verification Test Items	-----	3-1 of 72
Table 3-2	Additional Performance Verification Items for Tracking Generator	-----	3-1 of 72
Table 3-3	Center Frequencies Setting for Displayed Average Noise Level	-----	3-9 of 72
Table 3-4	Setting for Displayed Average Noise Test	-----	3-10 of 72
Table 3-5	Setting for Displayed Average Noise Level Test	-----	3-10 of 72
Table 3-6	Setting for RBW Switching Uncertainty Test	-----	3-12 of 72
Table 3-7	Setting for RBW and Span for 3dB Down Width Measurement	-----	3-15 of 72
Table 3-8	Setting for RBW Selectivity Test	-----	3-16 of 72
Table 3-9	Setting for Step IF Gain Uncertainty Test (RBW 1MHz)	-----	3-19 of 72
Table 3-10	Setting for Input Attenuator Switching Accuracy Test	-----	3-21 of 72
Table 3-11	Setting for 1 dB/div Scale Fidelity Test	-----	3-24 of 72
Table 3-12	Setting for 10dB/div Scale Fidelity Test	-----	3-26 of 72
Table 3-13	Setting for Linear Scale Fidelity Test	-----	3-27 of 72
Table 3-14	Setting for Noise Sidebands Test	-----	3-32 of 72
Table 3-15	Setting for Image, Multiple, Out of Band Response Test	-----	3-35 of 72
Table 3-16	Setting for Frequency Readout Accuracy Test	-----	3-37 of 72
Table 3-17	Setting of Frequency Counter Marker Accuracy	-----	3-38 of 72
Table 3-18	Setting for Center and Span Frequencies for Span Accuracy Test	-----	3-48 of 72
Table 3-19	Setting for Third Order Intermodulation Test	-----	3-51 of 72
Table 3-20	Setting for Sweep Time Accuracy Test	-----	3-58 of 72
Table 3-21	Setting for Output Flatness Test	-----	3-65 of 72
Table 3-22	Setting for TG output Level Switching Accuracy Test	-----	3-67 of 72
Table 3-23	Setting for TG Output Switching Accuracy Test	-----	3-67 of 72
Table 3-24	Setting for harmonic Distortion Test	-----	3-69 of 72
Table 5-1	Correspondence between performance verification and failure block	-----	5-3 of 8
Table 5-2	Correspondences between Performance Verification and Failure Block with TG Option	-----	5-4 of 8
Table 6-1	Replaceable Parts List	-----	6-1 of 1

1. GENERAL INFORMATION

This chapter contains following information,

- 1.1 Introduction
- 1.2 Outline of Product
- 1.3 Specifications;
- 1.4 Service Concept
- 1.5 Test Equipment Required for Performance Verification Test

1.1. Introduction

This manual provides information to perform unit or assembly level troubleshooting included removal/Installation procedures of instrument's module assemblies and a parts list.

This manual is intended for use by trained service personnel only.

Detailed operation and programming information is excluded from this manual. Including only sufficient information for service purpose. For more detailed operation information, refer to the U3661 spectrum analyzer operation manual.

WARNING!

The information in this manual is for use of Service Trained Personnel only. To avoid electrical shock, do not perform any procedures in this manual or do any servicing to the U3661, unless you are qualified to do so.

This manual has information the following six chapters.

1. GENERAL INFORMATION
It provides description of this manual and brief product information, Specification and Test equipment required for performance verification.
2. THEORY OF OPERATION
It provides the principle of measurement.
3. PERFORMANCE VERIFICATION TEST PROCEDURE
It provides the procedures for performance verification test and performance verification test record sheet.
4. ADJUSTMENT PROCEDURE
It provides the adjustment procedures for instruments, in case of required adjustment.
5. TROUBLESHOOTING
It provides the diagnostic procedure including the removal of defective module and installation procedures.
6. PARTS LIST
It provides the replaceable parts list.

1. GENERAL INFORMATION

1.2. Outline of Product

The U3661 is a very portable Spectrum Analyzer. That has been developed to be used for maintenance inspections and the like in location always from the lab bench and often out of doors in field. This analyzer is small and light (about 8.5 Kg), and it has a color LCD display. To further increase portability, there are three-power supply choice: A removable battery, AC/DC Adapter or an external DC supply.

It operates in the following frequency and input.

U3661	
Input Impedance	50Ω
Frequency range	9 kHz to 26.5 GHz
Input Range	
Pre-amplifier ON:	-132 dBm to + 13 dBm (9 kHz to 3 GHz)
Pre-amplifier OFF:	-118 dBm to +27 dBm

In these range, the analyzer features a maximum resolution of 1 kHz (100 Hz with option 26), a residual FM of 60 Hzp-p, and noise sideband of -100 dBc/Hz (at 10 kHz from the carrier). The analyzer equipped with GPIB remote control, RS232 remote control and memory card function for saving and recalling waveform data and panel setting.

The analyzer provides the following additional features

1. Three power supply source: battery, AC/DC adapter and external DC supply.
2. The ability to sweep over a wide frequency range: 9 kHz to 26.5 GHz.
3. A precious measurement mode that uses the analyzer's built-in reference crystal
4. to measure with 1 Hz accuracy signals too weak to measure with a counter.
5. Preamplifier, which is equipped with the gain 15 dB, or more in the frequency range 9 kHz to 3 GHz.
6. A memory card that can store waveform and control settings.
7. A digital memory LCD screen that displays signal trace without flickering.
8. Digital memory also allows to marker functions for accurate and easy reading of trace values.
9. A zero span mode that allows the analyzer to be set to a sweep time of 50 s.
10. Two independent channels of digital memory for simultaneous display of two traces.
11. Computer-controlled operation using GPIB command set.
12. The analyzer is equipped with delay-sweep function.
13. Option 20 is the high stability 10 MHz oscillator for more accurate measurement.
14. Option 26 is the active filter to have 100 Hz to 300 Hz resolution bandwidth.
15. Option 72 is TV signal demodulator, such as NTSC, PAL and SECOM.
16. Option 74 is tracking generator to allow measuring amplitude characteristics of devices.

1. GENERAL INFORMATION

1.3. Specification

Frequency

Frequency range	9 kHz to 26.5 GHz Frequency band 9kHz to 3.2GHz 3.0GHz to 7.1GHz 6.7GHz to 14.5GHz 13.7GHz to 26.5GHz	Harmonic mode (N) 1 (band 0) 1 (band 1) 2 (band 2) 4 (band 4)
Frequency readout accuracy (Start, Stop, CF, Marker)	\pm (Frequency readout \times freq reference error + 5% \times span + 15% \times RBW + 60 Hz \times N)	
Count frequency marker Resolution Count Accuracy	1 Hz to 1 kHz \pm (marker frequency \times freq. reference accuracy + 1 LSD \pm 5Hz \times N) (S/N \geq 25dB, 1kHz \leq SPAN \leq 200 MHz RBW \geq 3kHz)	
Frequency reference Aging Temperature stability	$\pm 2 \times 10^{-6}$ / year $\pm 1 \times 10^{-5}$ (from 0°C to 50°C) <i>see options for higher performance Reference</i>	
Frequency span Range Accuracy	1 kHz to 26.7 GHz and 0 Hz (zero span) $\leq \pm 5\%$ of Span	
Residual FM Zero Span	≤ 60 Hz pp \times N / 100 ms <i>see options for higher performance Reference</i>	
Frequency Drift Span = 10 KHz	(after warm up 30 min and at constant temperature) < 150 Hz \times N \times sweep speed (minutes)	
Noise Sidebands	F < 7.1GHz (Band 0 and Band 1) ≤ -105 dBc at 20 kHz offset ≤ -100 dBc at 10 kHz offset F > 6.7GHz $\leq (-105 + 20\log N)$ dBc at 20 kHz offset $\leq (-100 + 20\log N)$ dBc at 10 kHz offset	
Resolution Bandwidth At 3dB: Range RBW Accuracy Selectivity	1 kHz to 3 MHz 1-3 sequence <i>See Options for 300 Hz & 100 Hz RBW</i> $< \pm 20\%$ from 1 kHz to 1 MHz $< \pm 25\%$ for 3 MHz $< 15:1$ (60 dB : 3 dB) for RBW:1kHz to 3 MHz	
Video Bandwidth	10 Hz to 3 MHz (1-3 step)	

1. GENERAL INFORMATION

Amplitude Range

Measurement range	+ 30 dBm to displayed Average Noise Level
Maximum input level Preamplifier OFF	(Input attenuator ≥ 10 dB) + 30 dBm 0 VDC max.
Preamplifier ON	+ 13 dBm 0 VDC max.
Display range Log	10 \times 10 div 10, 5, 2, 1 dB/DIV
Linear	10% of reference level/div RBW ≥ 3 kHz
Reference level range Preamplifier OFF Log Linear	(Input attenuator 0 to 50 dB) -64 dBm to +40 dBm (0,1 dB step) 141.1 μ V to 22.36V
Preamplifier ON Log Linear	(Input attenuator 0 to 10 dB) -84.4 dBm to -20.4dBm (0.1 dB step) 7.934 μ V to 12.57 mV
Input attenuator range	0 to 50 dB (10 dB step)

1. GENERAL INFORMATION

Dynamic Range

Displayed Average Noise Level	with RBW 1 kHz, VBW 10 Hz and input attenuator 0 dB, $f \geq 1$ MHz														
Preamplifier OFF	band 0 : - 117 dBm + 2 f (GHz)dB band 1 : - 115 dBm band 2 : - 110 dBm band 4 : - 105 dBm														
Preamplifier ON	in 1 MHz to 3.2 GHz range -132 dBm + 3 f (GHz)dB														
Gain compression (1dB) Preamplifier OFF Preamplifier ON	Frequency ≥ 10 MHz, input attenuator 0 dB > -10 dBm (mixer input level) > -30 dBm (RF input level)														
Spurious Response	Preamplifier OFF														
Second harmonic distortion	<table border="1"> <thead> <tr> <th>Freq. range</th> <th>mixer level</th> <th>distortion level</th> </tr> </thead> <tbody> <tr> <td>10 MHz to 1.7 GHz</td> <td>-30 dBm</td> <td>≤ -70 dBc</td> </tr> <tr> <td>1.7GHz to 32GHz</td> <td>-10 dBm</td> <td>≤ -80 dBc</td> </tr> <tr> <td>above 3.2 GHz</td> <td>-10 dBm</td> <td>≤ -100 dBc</td> </tr> </tbody> </table>	Freq. range	mixer level	distortion level	10 MHz to 1.7 GHz	-30 dBm	≤ -70 dBc	1.7GHz to 32GHz	-10 dBm	≤ -80 dBc	above 3.2 GHz	-10 dBm	≤ -100 dBc		
Freq. range	mixer level	distortion level													
10 MHz to 1.7 GHz	-30 dBm	≤ -70 dBc													
1.7GHz to 32GHz	-10 dBm	≤ -80 dBc													
above 3.2 GHz	-10 dBm	≤ -100 dBc													
Third order intermodulation distortion	≤ -70 dBc (-30 dBm Input)														
Image/Multiple/Out-of-band response	< -70 dBc Band 0 < -60 dBc Band 1, Band 2 < -50 dBc Band 4														
Residual responses	(input terminated 50 Ω , input atten 0 dB)														
Preamplifier OFF	from 1 MHz to 3.2GHz	above 3.2 GHz													
Preamplifier ON	≤ -100 dBm	≤ -90 dBm	not applicable												
	≤ -105 dBm														

1. GENERAL INFORMATION

Amplitude Accuracy

Frequency Response	(after Calibration and Preselector peak)
Preamplifier OFF	$\leq \pm 1$ dB (100 kHz to 2.7 GHz) $\leq \pm 2$ dB (9 kHz to 3.2 GHz) $\leq \pm 1.5$ dB (3GHz to 7 GHz) $\leq \pm 3.5$ dB (7 GHz to 14.4GHz) $\leq \pm 4.0$ dB (14.4 GHz to 26.5 GHz)
Preamplifier ON	$\leq \pm 5.0$ dB (9 KHz to 26.5 GHz) (/ ref 30 MHz) $\leq \pm 1$ dB (100 kHz to 2.7 GHz) $\leq \pm 2$ dB (9 kHz to 3.2 GHz)
Calibration Signal Accuracy	-20 dBm \pm 0.3 dB
IF Gain Uncertainty	(after automatic calibration) < \pm 0.5 dB
Scale Fidelity	(after automatic calibration)
Log	$\leq \pm 1.5$ dB / 90 dB $\leq \pm 1$ dB / 10 dB $\leq \pm 0.2$ dB / 1 dB
Linear	± 5 % of reference level, RBW \geq 3kHz
Input attenuator switching accuracy	(0 to 50 dB settings, referenced to 10dB) $\leq \pm 1.1$ dB (9 kHz to 12 GHz) $\leq \pm 1.3$ dB (12 GHz to 20 GHz) $\leq \pm 1.8$ dB (20 GHz to 26.5 GHz)
Resolution bandwidth switching uncertainty	(after automatic calibration) < \pm 1.0 dB at RBW referenced to 3 MHz

Sweep

Sweep time	50 μ s to 1000 s and manual sweep
Accuracy	< \pm 5%
Trigger mode	FREE RUN, SINGLE, VIDEO, EXT, TV

Demodulation

Sound demodulation Modulation type Audio output	AM and FM (RBW \geq 3kHz for FM) Speaker and phone jack with volume control
---	--

Inputs & Outputs

RF Input Connector Impedance VSWR / Preamplifier OFF VSWR / Preamplifier ON	N type (Can be converted into SMA type) 50 Ω (nominal) < 1.5: 1 (100kHz to 3 GHz) < 2 : 1 (3 GHz to 26.5 GHz) with input atten 10 dB to 50 dB < 2.5:1 (9 kHz to 3.2 GHz)
10 MHz Reference input Connector Impedance Input Range	BNC female, rear panel 500 Ω (nominal) 0 dBm to +16 dBm
Video output Connector Impedance Amplitude	BNC female, rear panel 75 Ω (nominal) AC coupled approx. 1 Vpp 75 Ω (Composite video, signal)
External Trigger input Connector Impedance Trigger level	BNC female, rear panel 10 k Ω (nominal), DC coupled TTL level
Gate input Connector Impedance Sweep stop Sweep continue	BNC female, rear panel 10 k Ω (nominal) during TTL low level during TTL high level
Phone Output Connector Power Output	Sub miniature monophonic jack, front panel 0.2 W 8 Ω (nominal)
GPIB interface Plotter Printer	IEEE-488,bus Connector R9833, HP 7470A, HP 7475A, HP 7440A, HP 7550A 682-XA HP2225A
RS232	D-SUB 9 pins, rear panel

1. GENERAL INFORMATION

Power input Battery mounter adapter	Advantest AC/DC adapter Model : A08364 Automatically selections between 100VAC and 220VAC Anton Bauer Inc: Magnum 14 battery (nominal 72WH) Magnum HD battery (nominal 60WH)
TV picture demodulation output Connector Impedance Amplitude	OPTION BNC female, rear panel 75 Ω (nominal), DC coupled Approx. 1Vp-p, 75 Ω termination
TV sound demodulation output Connector Impedance	OPTION Pin female, rear panel 1k Ω (nominal) AC coupled
TV picture signal input Connector Impedance Input level	OPTION BNC female, rear panel 75 Ω (nominal), AC coupled Approx. 1Vp-p
TV sound signal input Connector Impedance	Pin female, rear panel 1k Ω (nominal) AC coupled

General specifications

Environment temperature Operating temperature Relative humidity Storage temperature	0°C to 50°C RH 85% or less -20°C to 60°C
Power supply External DC input During AC adapter is used During 100 VAC operation During 220VAC operation Power consumption	Connector :XLR 4 pin Input range: +10V to +16V Automatically selections between 100VAC and 220VAC Voltage: 100V to 120V Frequency : 50Hz/60Hz Voltage: 220V to 240V Frequency: 50Hz/60Hz During DC operation: 70W max. During AC adapter is used: 130VA
Mass	8.5 kg or less (Without option, accessory, carrying belt and battery PROPAC 14 battery: 2.1kg AC/DC adaptor (A08364): 1.1kg
Dimensions	Approx. 148mm (height) x291 mm (wide)x330 mm(depth) excluding the projecting(legs, connector, etc...)
External memory Memory card	2 slots, upper panel Connector:JEIDA-Ver4.1, PCMCIA Rel 2.0

1.4. Service Concept

The troubleshooting concept of this manual is based on performance verification test result approach.

Replaceable assemblies listed in chapter 6 are no required adjustment after replace.

1.5. Test Equipment Required for Performance Verification Test

Table1-1 lists the recommended equipment for performance verification and adjustment.

In the usage column, P.V and Adj are abbreviation of Performance Verification and Adjustment.

The equipment needed to perform all of the performance test.

Equipment lists for individual tests are provided in each performance verification test.

Any equipment that meets the critical specifications given in the table can be substituted for the recommended models.

Table1-1. Equipment Required for Performance Test and Adjustment

No.	Description	Critical Specification	Recommended model	Manufacturer	Usage	Notes
1	Frequency Standard	Output Frequency: 10MHz Output Level: 1Vp-p or more Stability: 5 x 10exp -10/day or more	R3031	Advantest	P.V, Adj.	Freq.STD
2	Frequency Counter	Frequency Range: Over 10MHz Resolution: 0.1Hz, 9digits Input Sensitivity: 70mVrms or better	R5372	Advantest	P.V, Adj	Freq.CNT
3	Signal Generator	Frequency Range: 10MHz to 18GHz Output Level: +10dBm to -5dBm Frequency Stability: 1 x 10exp-6/year	SMP02(B11)	Rohde & Schwartz	P.V	SG1
4	Signal Generator	Frequency Range:10MHz to 27GHz, Output Level: +10dBm to -5dBm Frequency Stability: 1 x 10exp-6/year	SMP03 (B11+B15)	Rohde & Schwartz	P.V	SG2
5	Signal Generator	Frequency Range: 10MHz to 2.7GHz Output Level: 0dBm to -30dBm Residual SSB, Phase Noise @ 1kHz offset: < -115dBc @ 10kHz offset: < -125dBc @ 100kHz offset: < -130dBc	HP8663A	HP	P.V	SG3
6	Signal Generator	Frequency Range: 10MHz to 20MHz Output Level: +13dBm to -10dBm Frequency Stability: 1 x 10 exp-6/year Squarewave Generation required	HP3325B	HP	P.V	SG4
7	RF Power Meter /RF Power Sensor	Frequency Range:10MHz to 26.5GHz Measurement Power Range: +10dBm to -30dBm	NRVS / NRVS-Z52	Rohde & Schwartz	P.V	PM/PS
8	Step Attenuator	Frequency Range: DC to 18GHz Attenuation: 0dB to 12dB by 1dB step Accuracy: 0.1dB	HP8494H	HP	P.V	ATT1
9	Step Attenuator	Frequency Range: DC to 18GHz Attenuation: 0dB to 70dB by 10dB step Accuracy: 0.1dB	HP8495H	HP	P.V	ATT2
10	Attenuator Driver	Compatible with HP 8494H and 8495H Programmable step attenuators	HP11713A	HP	P.V	-
11	Terminator	Impedance: 50Ω Type: N(m)	RNA	Rohde & Schwartz	P.V	TERM50
12	Fixed Attenuator	Attenuation:3dB, Impedance:50Ω Type:SMA(m)-SMA(f)	DEE-000685-1	Advantest	P.V	ATT3
13	Fixed Attenuator	Attenuation:20dB, Impedance:50Ω, Type: SMA(m)-SMA(f)	DEE-000480-1	Advantest	P.V	ATT4
14	Power Splitter	Frequency Range: 10MHz to 26.5GHz, Impedance: 50Ω Type: SMA(f)-SMA(f)-SMA(f)	1579	Weinshel	P.V	-
15	Power Divider	Frequency Range: 20MHz to 1.5GHz Isolation: >18dB	DDUL-20A-100	Merrimac	P.V	Divider1
16	Power Divider	Frequency Range: 2GHz to 18GHz Isolation: >18dB	DDUL-24M-10G	Merrimac	P.V	Divider2
17	Low Pass Filter	Cut off: 2.2GHz Attenuation at 3GHz: >40dB Attenuation at 3.8GHz: >80dB	DEE-001172-1	Advantest	P.V	L.P.F
18	BNC-BNC Cable	Impedance: 50Ω, Type: BNC(m)-BNC(m)	MI-09	Advantest	P.V	-
19	SMA-SMA Cable	Impedance:50Ω, Type: SMA(m)-SMA(m)	A01002	Advantest	P.V	-
20	Adapter	Impedance: 50Ω Type: N(m)-SMA(f)	HRM-554S	Advantest	P.V	-
21	Adapter	Impedance: 50Ω, Type: SMA(f)-SMA(f)	HRM-501	Advantest	P.V	-
22	Adapter	Impedance: 50Ω Type: N(f)-BNC(m)	NJ-BNCP	Advantest	P.V	-
23	Adapter	Impedance: 50Ω Type: N(m)-BNC(f)	JUG-201A-U	Advantest	P.V	-
Additional Equipment for Tracking Generator Option						
24	Spectrum Analyzer	Frequency Range: up to 8 GHz	Advantest	R3267	P.V for TG Option	SPA

2. THEORY OF OPERATION

2.1. Introduction

This section provides theory of operation of module basis, which is replaceable with no adjustment.

Module basis operation of theory is provided by module by module.

U3661 consists of RF Block, IF/LOG Block, AD Block, CPU Block and DC/DC Block.

Tracking Generator is optional. Tracking Generator Block is installed alternative to LOG Block as option 74.

The simplified block diagram as shown in Figure 2-1.

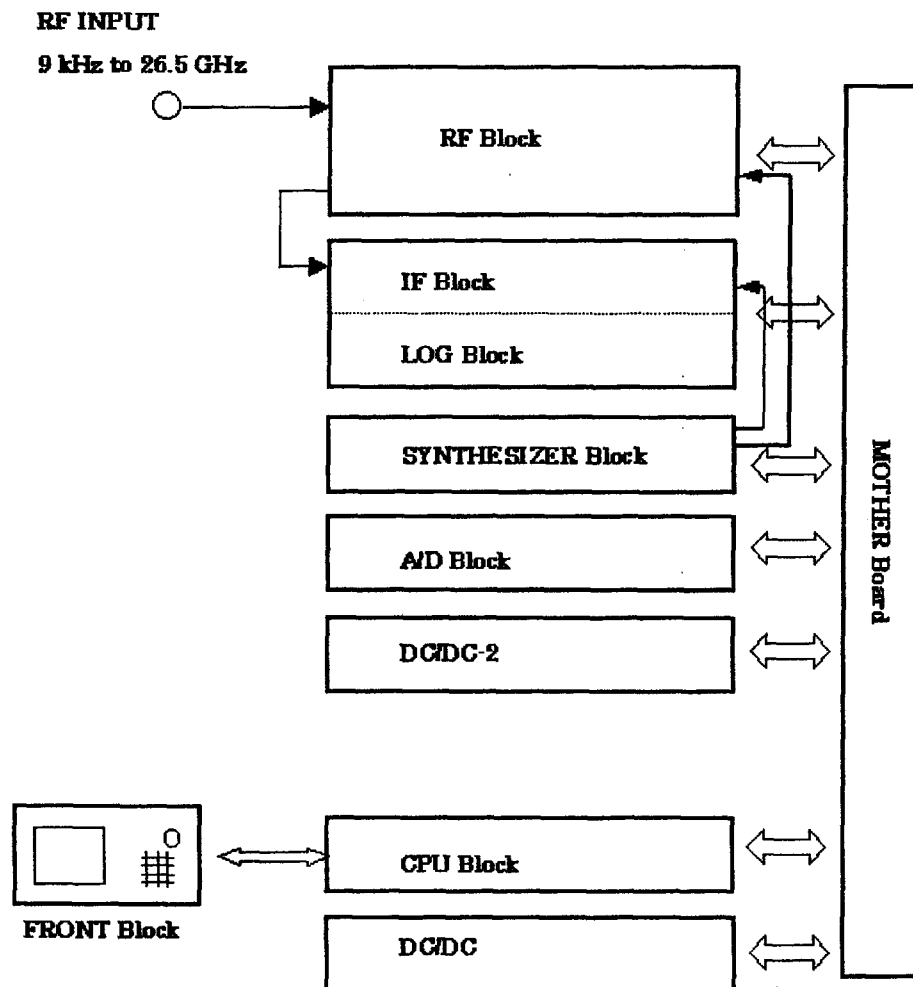

Figure 2-1 Simplified Block Diagram of U3661

2. THEORY OF OPERATION

2.2. Over All Theory of Operation

U3661 converts the input signal into 21.4 MHz intermediate frequency (Hereafter: IF) signal. The input signal must be in the range 9 kHz to 26.5 GHz. The signal is then filtered with variable resolution bandwidth filters. The detector detects the signal, and digitized and displayed on the screen.

2.3. RF Block

RF block is a frequency converter.

It consists of input attenuator, 1st and 2nd mixers, 1st and 2nd local oscillators and band pass filters.

In the range from 9 kHz to 26.5 GHz, the signal is fed through the input attenuator, which can attenuate 0 dB to 50dB in 10 dB step.

The input signals, which range from 9 kHz to 3 GHz is fed into the 1st mixer.

The input signal then mixes with signal of 1st local oscillator 4 GHz to 7GHz to create 1st IF signal 4061.4 MHz.

The 1st IF signal passes through the band-pass filter to eliminate spurious signal generated by 1st mixer.

After the band-pass filter, the IF signal is fed into 2nd mixer.

The 2nd mixer mixes 1st IF signal with the signal of 2nd oscillator of 3840 MHz to create 2nd IF signal 221.4 MHz.

The signal, which range from 3 GHz to 26.5 GHz is converted frequency of 2nd IF signal 224.4 MHz directly.

2.4. IF Block

IF block consists of a frequency converter, variable IF filters and step amplifier Circuits.

The 2nd IF signal passes through band-pass filter to eliminate the image signal generated by the 1st mixer, then the signal is fed into 3rd mixer.

The 3rd mixer mixes the signal with 3rd local oscillator of 200 MHz to create 3rd IF signal 21.4 MHz. The 3rd local signal 200 MHz is supplied from SYNTH Block.

The 3rd IF signal is fed into IF filter, which has variable resolution bandwidth to specify resolution bandwidth.

The IF filter is switched from 3 kHz to 3 MHz by RBW setting on the control

The signal specified from IF filter is fed into step amplifier circuit.

The step amplifier has gain 50 dB by 0.1 dB step, which controls by REFERENCE LEVEL setting on the control.

The signal characterized in IF filter and step amplifier is fed into LOG/AD Block.

2.5. LOG Block

LOG Block consists of logarithm (Hereafter: LOG) amplifier, linear amplifier and detector circuit.

The signal from IF Block is fed through LOG amplifier, which provides 100 dB dynamic range display in dB display mode.

In the linear display mode, the signal passes through linear amplifier and detector circuit.

2.6. A/D Block

After signal detected, the signal is fed into A/D converter to digitize.

The digitized signal is then computed by CPU Block and display on the screen.

2.7. SYNTHESIZER Block

SYNTH Block consists of reference oscillator and phase locked loop circuit and oscillators.

The phase locked loop circuit stabilize 1st local and 2nd local oscillator in the RF Block.

The 200 MHz signal generate for 3rd local signal in the IF Block.

2.8. DC/DC Block

DC/DC Block consists of DC/DC converter.

It generates DC voltage of ± 12 V, ± 8 V and + 5 V for mainframe.

2.9. DC/DC-2 Block

DC/DC-2 consists of DC/DC converter.

It generates voltage of ± 12 V and ± 8 V for RF Block.

2.10. CPU Block

It consist of CPU main processor, Graphic processor and its peripheral circuit, such as GPIB interface, RS232 Interface and display.

On the CPU Block compute the digitized signal for the display

2.11. FRONT Block

FRONT Block consists of TFT display unit and key control circuit.

2. THEORY OF OPERATION

2.12. TG Block

TG Block consists of tracking generator and LOG board.

It generates frequency 100 kHz to 2.2 GHz and output level 0 dBm to -31 dBm by 1 dB step.

LOG board functions same as LOG Block.

3. PERFORMANCE VERIFICATION

3.1. GENERAL

1. INTRODUCTION

This chapter provides U3661 performance verification test procedures, item by item as listed in Table 3-1.

Additional performance verification test items are listed in Table 3-2 for Tracking Generator Option 74.

Performance verification test will be carried out under following condition.

Temperature range: 20 °C to 30 °C

Relative Humidity: 85 % or less

Table 3-1 Performance Verification Items

No.	Items	Applicable Model
		U3661
3.2.1	10 MHz Reference Oscillator Accuracy	○
3.2.2	Calibration Signal Output Amplitude Accuracy	○
3.2.3	Displayed Average Noise	○
3.2.4	RBW Switching Uncertainty	○
3.2.5	RBW Accuracy	○
3.2.6	Attenuator Switching Accuracy	○
3.2.7	IF Gain uncertainty	○
3.2.8	Scale Fidelity	○
3.2.9	Residual FM	○
3.2.10	Noise sideband	○
3.2.11	Image, Multiple, Out of Band Spurious	○
3.2.12	Frequency Read Out Accuracy	○
3.2.13	Second Harmonic Distortion	○
3.2.14	Frequency Response	○
3.2.15	Span Accuracy	○
3.2.16	Third Intermodulation Distortion	○
3.2.17	Gain Compression	○
3.2.18	Sweep Time Accuracy	○
3.2.19	Residual Response	○

Table 3-2 Additional Performance Verification Items for Tracking Generator

No.	Items	Applicable Model
		U3661
3.3.1	Absolute Output Level Accuracy	○
3.3.2	Output Flatness	○
3.3.3	Output Level Changeover Accuracy	○
3.3.4	Harmonics Distortion	○
3.3.5	Non-harmonics Distortion	○

3. PERFORMANCE VERIFICATION

2. TEST EQUIPMENT

The table of recommended test equipment in General information lists the equipment needed to perform all of the performance test.

Equipment lists for individual tests are provided in each performance verification test.

NOTE:

- 1. The U3661 to be tested should be warmed up for at least 60 minutes before starting tests. Any additional equipment used for this performance verification test should be warmed up as appropriate.*
- 2. Make sure that the test equipment used meets its own published specifications and that all connectors are clean, before starting test.*
- 3. Any equipment that meets the critical specifications given in the Table can be substituted for recommended models.*

3. CALIBRATION CYCLE

The performance verifications test should be used to check the spectrum analyzer against its specifications every one-year recommended.

The reference oscillator must be adjusted and checked at the same time.

Refer to the "Internal Frequency Reference Adjustment" in the chapter 4.

4. PERFORMANCE VERIFICATION TEST RECORD SHEETS

The performance verification test record sheets at the end of this chapter is provided the value measured in each performance verification test

The test record lists test specification and acceptable limits.

Recommend that make a copy of this table, record the complete test results on the copy, and keep the copy for calibration test record.

This record could prove invaluable in tracking gradual changes in test result over long periods of the time.

5. PERFORMANCE VERIFICATION TEST PROCEDURES

Typeface conventions used in this manual.

*Panel keys and soft keys are printed in a contrasting typestyle to make them stand out from the text as follows:

Panel keys: Boldface type Example: **FREQ, FORMAT**

Soft keys: Boldface and Italic Example: ***Center, Trace Detector***

*When a series of key operations are described using a comma between two keys.

*There are various soft menus used to switch between two states such as ON/OFF and AUTO/MNL.

For example, when turning off the *Display ON/OFF function*, the annotation

“*Display ON/OFF (OFF)*” is used.

When switching the RBW AUTO/MNL function to MNL, the annotation

“*RBW AUTO/MNL (MNL)*” is used.

3. PERFORMANCE VERIFICATION

3.2 PERFORMANCE VERIFICATION PROCEDURE

3.2.1. 10 MHz Reference Output Accuracy

Description

Apply 3 GHz output of signal generator referenced external signal standard.
 Then measure 3 GHz signal using U3661 frequency counter function.
 U3661's frequency counter measurement accuracy is referenced to 10 MHz reference oscillator.

Specification

Frequency $\pm 2 \times 10 \text{ exp } -6$

Related Adjustment

10 MHz reference Source Adjustment Chapter 4 Section 4-1.

Equipment used

Signal Generator	:SG2
Frequency Standard	:Freq.STD.
RF Cable	:BNC(m)-BNC(m)
RF Cable	:SMA(m)-SMA(m)
Adapter	:N(m)-SMA(f)

Setup

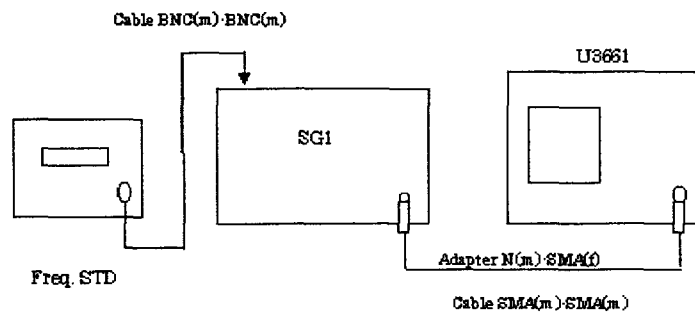

Figure 3-1 Setup of Frequency Reference Output Accuracy Test

3. PERFORMANCE VERIFICATION

Procedure

1. Connect the equipment as shown in Figure 3-1.
2. On the SG1, set controls as follows:

FREQUENCY REFERENCE	:EXT
Frequency	:3GHz
Output level	:-10dBm

3. On the U3661, set controls as follows:

Center Frequency	:3GHz
Span	:2MHz
RBW	:30kHz
Cont. peak	:ON
Counter	:ON
Counter Resolution	:10Hz

4. Read the frequency counter display, then record on the performance verification test record sheets.

3.2.2. Calibration Signal Output Amplitude Accuracy

Description

The amplitude accuracy of the analyzer's CAL OUT signal is checked for -20 dm ± 0.3 dB.

Specification

Calibration Signal Accuracy	:-20 dBm ± 0.3 dB
-----------------------------	-------------------

Equipment used

RF Power Meter	:P.M
PF Power Sensor	:P.S
Signal Generator	:SG2
Fixed Attenuator	:ATT3
RF Cable	:SMA(m)-SMA(m)
RF Cable	:BNC(m)-BNC(m)
Adapter	:N (m)-SMA (f)

3. PERFORMANCE VERIFICATION

Setup

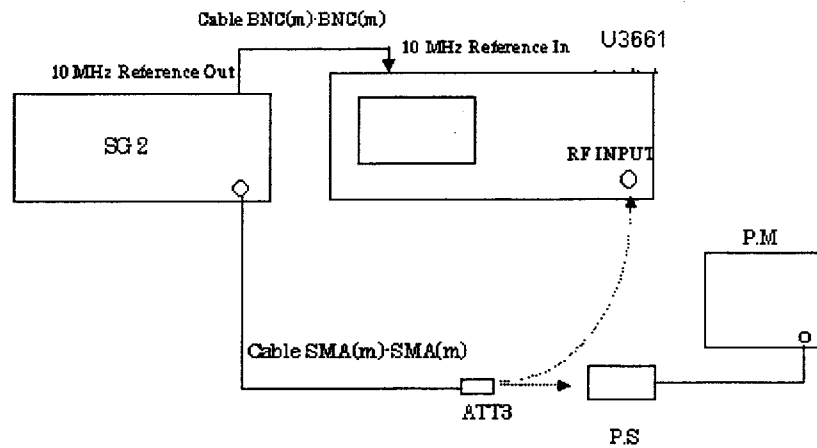

Figure 3- 2 Setup of CAL OUT Level Accuracy Test

Procedure

1. On the P.M, perform ZERO and calibration.
2. On the P.M, set a calibration factor at 30 MHz.
3. On the SG2, set controls as follows:

Frequency	:30MHz
Output Level	:-20 dBm

4. Connect sensor through fixed Attenuator, SMA (m)-SMA (m) cable and Adapter directly to the SG2's output connector.
5. On the SG2, adjust output level so that P.M reading is -20 dBm ± 0.09 dB.
6. Apply SG2 output to U3661, through fixed attenuator, SMA (m)-SMA (m) cable and adapter as shown in Figure 3-2.
7. On the U3661, set controls as follows:

Center Frequency	:30MHz
Span	:1MHz
Reference Level	:-15dBm
dB/div	:1dB/div
RBW	:300kHz
CAL sig	:OFF

8. Measure peak level and record on the performance verification test data record sheets as reference.
9. On the U3661, set CAL sig to on.
10. Measure the peak of calibration signal and record it as measured data.
11. Calculate level difference between reference and measured data, and then record on the performance verification test record sheets.

3.2.3. Displayed Average Noise Level

Description

This test measures the displayed average noise level in all frequency.

The spectrum analyzer's input is terminated in 50Ω.

In Frequency Band 0, the test first measures the average noise at several discrete frequencies in a zero span. For the rest of Frequency Band 0, and all other bands, the test tunes the analyzer frequency across the band, uses the marker to locate the frequency with the highest response, then reads the average noise in a zero span.

Specification

Pre-amplifier OFF

Frequency	Frequency Band	Average Noise Level
1 MHz to 3.2 GHz	0	-117 dBm + 2f(GHz) dBm
3 GHz to 7.1GHz	1	-105 dBm
6.7 GHz to 14.5 GHz	2	-110 dBm
13.7 GHz to 26.5GHz	3	-105 dBm

Pre-amplifier ON

Frequency	Frequency Band	Average Noise Level
1 MHz to 3.2 GHz	0	-132 dBm + 3f(GHz) dBm

Equipment used

Terminator 50Ω :NRA

3. PERFORMANCE VERIFICATION

Setup

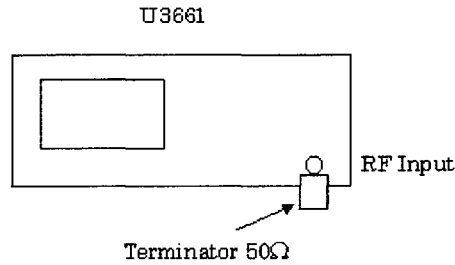

Figure 3-3 Setup of Displayed Average Noise Level Test

Procedure

[Pre-amplifier Off Condition]

1. Connect Terminator to INPUT of U3661 as shown Figure 3-3.

[For frequency band 0]

2. On the U3661, after preset, set controls as follows:

Center Frequency	:1MHz
Span	:ZERO
RF Attenuator	:0dB
Reference Level	:-60dBm
RBW	:1kHz
VBW	:10Hz
Sweep Time	:1 sec

3. On the U3661, press as follows to set AVG mode and AVG times to 10 times.

TRACE, AVERAGE, 1, 0, Hz

4. After average has completed, set U3661 to peak search mode to capture the highest noise signal by pressing **PEAK**.
5. Record the level of peak search marker on the performance check sheets.
6. Repeat steps 4 through 5 for each Center Frequency setting listed on Table4.

Table 3-3 Center Frequencies Setting for Displayed Average Noise Level

Center Frequency
10.1 MHz
101 MHz
501 MHz
1001 MHz
1.5 GHz
2.0 GHz
2.5 GHz
3.0GHz

[For frequency band 1]

7. On the U3661, after preset, set controls as follows:

Start Frequency	:3.0GHz
Stop Frequency	:7.1GHz
Input Attenuator	:0dB
Reference Level	:-40dBm
RBW	:3MHz
VBW	:100kHz

8. On the U3661 press as follows to set AVG mode and AVG times to 10 times.

TRACE, AVERAGE, 1, 0, Hz

9. On the U3661, after average has completed, press **PEAK** to capture the highest noise signal.

Then press, **MKR→, MKR→CF and A, WRITE A**

10. On the U3661, set U3661 controls as follows:

Span	:ZERO
Reference Level	:-60dBm
RBW	:1kHz
VBW	:10Hz
Sweep Time	:1 sec

11. On the U3661, press as follows for single sweep.

MENU, SWEEP MODE and SINGLE SWEEP

12. After single sweep has completed, set U3661 to peak search marker mode **PEAK** to capture the highest noise signal.

3. PERFORMANCE VERIFICATION

13. Record the level of peak search marker reading on the performance verification test record sheets.
14. Repeat steps 7 through 13 for each frequency setting listed in Table 3-4.

Table 3-4 Setting for Displayed Average Noise Test

Start Frequency	Stop Frequency
6.7 GHz	14.5 GHz
13.7 GHz	26.5 GHz

[Pre-amplifier ON Condition]

15. On the U3661, after preset, set controls as follows:

Center Frequency	:1MHz
Span	:ZERO
RF Attenuator	:0dB
Reference Level	:-60dBm
Pre-AMP	:ON
RBW	:1kHz
VBW	:10Hz
Sweep Time	:1 sec

16. Repeat steps 3 through 6 for each frequency listed in Table 3-5.

Table 3-5 Setting for Displayed Average Noise Level Test

Center Frequency
10.1 MHz
101 MHz
501 MHz
1001 MHz
2.0 GHz
2.5 GHz
3.0 GHz

3.2.4. Resolution Bandwidth Switching Uncertainty

Description

This set utilizes the Cal. Signal for measuring the switching uncertainty between resolution bandwidths. At each resolution bandwidth setting, the displayed amplitude variation of the signal is measured using delta marker mode.

All measurements are reference to the 3 MHz bandwidth.

RBW 100 Hz and 300 Hz are the option; if the unit is installed option26, perform verification.

Specification

Reference to 3 MHz RBW after auto calibration

$< \pm 1.0$ dB 30Hz to 3MHz
100Hz and 300Hz (Option26)

Equipment used

Nil

Setup

U3661

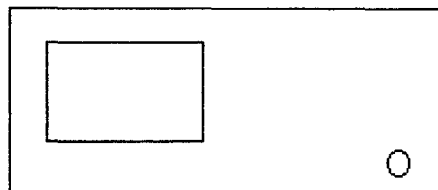

Figure 3-4 Setup of RBW Switching Uncertainty Test

Procedure:

1. On the U3661, after preset, press as follows to perform auto calibration function.

SHIFT, 7(CAL), Each Item, RBW SWITCH

3. PERFORMANCE VERIFICATION

2. On the U3661, after RBW SWITCH auto calibration has completed, set controls as follows:

Center Frequency :30MHz
 Span :5MHz
 Reference Level :-15dBm
 dB/div :1dB/div
 RBW :3MHz
 Sweep Mode :SINGLE
 Cal sig :ON

3. On the U3661, press as follows for single sweep.

MENU, SWEEP MODE and SINGLE SWEEP

4. On the U3661, after single sweep has completed, press **PEAK** to capture signal peak.
5. On the U3661, press as follows to set fixed marker mode to on.

MKR, Δ MKR, FIXED MK ON

6. On the U3661, set controls as follows;

RBW :1MHz
 Span :2 MHz

7. On the U3661, as follows for single sweep.

MENU, SWEEP MODE and SINGLE SWEEP

8. On the U3661, after single sweep has completed, press **PEAK** to capture signal peak.
9. Record the level of the delta marker on the performance verification test record sheets.
10. Repeat steps 7 through 9 for each RBW and span setting listed in Table 3-6.

Table 3-6. Setting for RBW Switching Uncertainty Test

RBW Setting	Frequency Span
300 kHz	1 MHz
100 kHz	200 kHz
30 kHz	50 kHz
10 kHz	20 kHz
3 kHz	5 kHz
1 kHz	2 kHz
300 Hz(Option)	1 kHz
100 Hz(Option)	1 kHz

3.2.5. Resolution Bandwidth Accuracy and Selectivity

Description

This test measures the 3 dB down of RBW accuracy and selectivity.

Accuracy test uses internal calibration signal.

Selectivity is specified the 3 dB and the 60dB down bandwidth of RBW.

To measure bandwidth of RBW, use continuous XdB down marker function.

RBW 100 Hz to 300 Hz are the option, if the unit is installed option-26, perform verification.

Specification

Range: 1 kHz to 3 MHz (1,3,10 sequence),
100 Hz to 300 Hz (Option)

Accuracy: $\pm 20\%$ (RBW 100 Hz to 1 MHz)
 $\pm 25\%$ (RBW 3 MHz)

Selectivity: <15:1 (RBW 100 Hz to 3 MHz)

Equipment used

Following equipment use for RBW selectivity test only.

Signal Generator	:SG2
Adapter	:N(m)-BNC(f)
RF Cable	:BNC (m)-BNC (m)

3. PERFORMANCE VERIFICATION

Setup

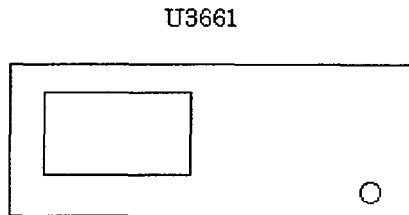

Figure 3-5 Setup of RBW Accuracy Test

Procedure:

[Accuracy of RBW]

1. On the U3661, after preset, set controls as follows;

Center Frequency	:30MHz
Span	:10MHz
Reference Level	:-18dBm
dB/div	:1dB/div
CAL sig.	:ON
Trace Detector	:Sample

(Press **MENU**, *Trace Det* and *Sample*)

2. On the U3661, press as follows to set continuous 3 dB down marker mode.

PEAK, MEAS 2, XdB Down, 3, dB and Continuous Down ON/OFF (ON)

3. On the U3661, set RBW to 3 MHz.
4. On the U3661, press as follows to set single sweep mode.

MENU, SWEEP MODE, SINGLE SWEEP

5. On the U3661, press as follows for single sweep.

MENU, SWEEP MODE and SINGLE SWEEP

6. On the U3661, after single sweep has completed, press **PEAK** to capture signal peak.
7. Record the frequency of the X dB down marker reading on the performance verification test record sheets.
8. Repeat steps 4 through 7 for each RBW and frequency span setting listed in Table 3-7.

Table 3-7 Setting for RBW and Span for 3dB Down Width Measurement

RBW Setting	Span
3 M	10 M
1 M	2 M
300 k	500 k
100 k	200 k
30 k	50 k
10 k	20 k
3 k	5 k
1 k	2 k

[Selectivity]

Setup

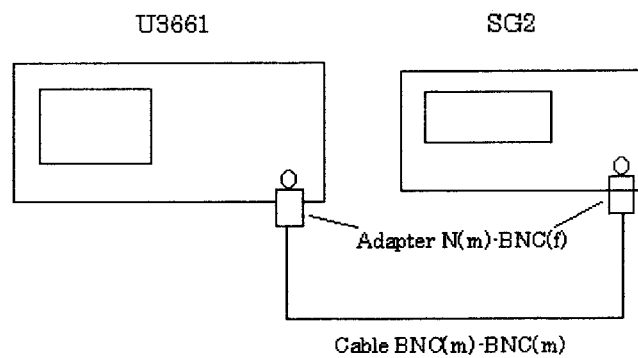

Figure 3-6 Setup of RBW Selectivity Test

Procedure

9. On the SG2, set controls as follows:

Frequency :30MHz
 Output Level :-10 dBm

10. On the U3661, after preset, set controls as follows:

Center Frequency :30MHz
 Span :50MHz
 Reference Level :0dBm
 Trace Detector :Sample

(Press **MENU**, **Trace Det** and **Sample**)

3. PERFORMANCE VERIFICATION

11. On the U3661, press as follows to set continuous 60 dB down marker mode.

PEAK, MEAS2, X dB Down, 6, 0, dB and Continuous Down ON/OFF (ON)

12. On the U3661, set RBW to 3 MHz.

13. On the U3661, press as follows to set single sweep mode.

MENU, SWEEP MODE and SINGLE

14. On the U3661, after single sweep has completed, press **PEAK** to capture signal peak.

15. Record the frequency of the X dB down marker reading on the performance verification test record sheets.

16. Repeat steps 12 through 15 for each RBW and frequency span setting listed in Table 3-8.

Table 3-8 Setting for RBW Selectivity Test

RBW Setting	Span
1 MHz	20 MHz
300 kHz	5 MHz
100 kHz	1 MHz
30 kHz	500 kHz
10 kHz	200 kHz
3 kHz	50 kHz
1 kHz	20 kHz
300 Hz(Option)	5 kHz
100 Hz(Option)	2 kHz

17. Calculate selectivity for each RBW using the following formula, then record its result in Selectivity column on performance verification test record sheets as.

$$\text{Selectivity} = (60\text{dB down width data}) / (3\text{dB down width data})$$

3.2.6. IF Gain Uncertainty

Description

This test measures IF gain error in resolution bandwidth 1 MHz, 3 kHz and 100 Hz (Option).

The input signal level is decreased by external attenuator as the U3661's reference level is decreased (IF gain increased).

Since the signal level is decreased in precise steps, any error between the reference level and the signal level is caused by analyzer's IF gain.

Specification

± 0.5dB

Equipment used

Signal Generator	:SG2
1dB Step Attenuator	:ATT1
10dB Step Attenuator	:ATT2
Attenuator/Switch Driver	:HP11713A
RF Cable	:BNC(m)-BNC(m)
Adapter	:N (m)-BNC (f)

Setup

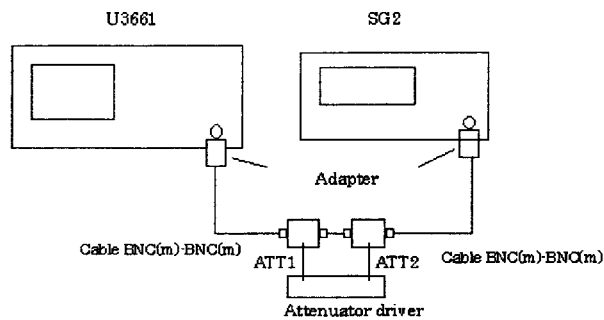

Figure 3-7 Setup of IF Gain Uncertainty Test

Procedure

[IF Gain]

1. On the U3661, press as follows to perform AUTO CAL function.

SHIFT, 7(CAL) and CAL ALL

2. After AUTO CAL function has completed, connect equipment as shown in Figure 3-7.
3. On the SG2, set controls as follows:

Frequency	:11MHz
Output Level	:-5 dBm

3. PERFORMANCE VERIFICATION

4. On the ATT1 and ATT2, set value to 0dB.
5. On the U3661, after preset, set controls as follows:

Center Frequency	:11MHz
Span	:ZERO
Reference Level	:0dBm
dB/div	:1dB/div
RBW	:1MHz
VBW	:100 Hz

6. On the SG2, adjust the output level to place the signal 5 dB below the U3661's reference level.
7. On the U3661, press as follows to set single sweep.

MENU, SWEEP MODE and SINGLE SWEEP

8. On the U3661, after single sweep has completed, press **PEAK** to capture signal peak.
9. On the U3661, press as follows to set TRACE A to VIEW mode.

TRACE, VIEW/BLAN (VIEW)

10. On the U3661, press as follows to set TRACE B to WRITE mode.

TRACE B and WRITEB

11. On the U3661, press as follows to activate marker on the trace A.

MARKER, NEXT and A<-> B (A)

12. On the U3661, press as follows to set delta marker mode to on and activate marker on the TRACE B.

MARKER, ΔMKR, MARKER, NEXT and A<->B (B)

13. On the external attenuator, increase the value to 1 dB.
14. On the U3661, decrease reference level to -1 dB.
15. On the U3661, press as follows to sent single sweep.

MENU, SWEEP MODE and SINGLE SWEEP

16. On the U3661, after single sweep has completed, press **PEAK** to capture signal peak.
17. Record the level of delta marker reading on the performance verification test record sheets.
18. Repeat steps 12 through 16 for each attenuation level setting listed in Table 3-9.

Table 3-9. Setting for Step IF Gain Uncertainty Test (RBW 1MHz)

Step Attenuator	Reference Level
2 dB	-2 dBm
3 dB	-3 dBm
4 dB	-4 dBm
5 dB	-5 dBm
6 dB	-6 dBm
7 dB	-7 dBm
8 dB	-8 dBm
9 dB	-9 dBm
10 dB	-10 dBm
20 dB	-20 dBm
30 dB	-30 dBm
40 dB	-40 dBm
50 dB	-50 dBm

19. For RBW 3 kHz and 100 Hz (Option), change the setting in step 5 to RBW 3 kHz and 100 Hz, then repeat steps 5 through 18.

3.2.7 Input Attenuator Switching Accuracy

Description

This test measures the input attenuator's switching accuracy over the full 50 dB range.

The number of frequency measured point at 4 GHz, 15 GHz and 18 GHz.

The input attenuator switching accuracy is referenced to 10dB attenuator setting.

Pre-selector tuning is required.

IF Gain uncertainty is measured when the resolution bandwidth is set to 3kHz and the result is filled in the IF Gain uncertainty of the performance verification test record sheets.

Specification

With reference to 10dB input attenuation, in the range 20dB to 50dB.

< ± 1.1 dB/10dB step, Frequency Range: 9 kHz to 12 GHz

< ± 1.3 dB/10dB step, Frequency Range: 12 GHz to 20 GHz

< ± 1.8 dB/10dB step, Frequency Range: 20 GHz to 26.5 GHz

Equipment used

Signal Generator	:SG2
RF Cable	:SMA(m)-SMA(m)
Adapter	:N (m)-SMA (f)

3. PERFORMANCE VERIFICATION

Setup

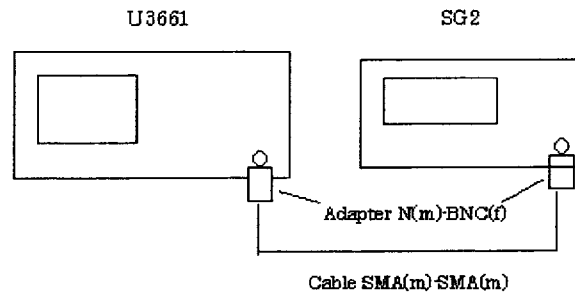

Figure 3-8 Setup of Input Attenuator Switching Accuracy Test

Procedure

1. Connect equipment as shown in Figure 3- 8.

2. On the SG2, set controls as follows:

Frequency	:4GHz
Output Level	:-5dBm

3. On the U3661, after preset, set controls as follows:

Center Frequency	:4GHz
Span	:10kHz
Reference Level	:0dBm
dB/div	:1dB/div
RBW	:3kHz
VBW	:10Hz
Sweep Time	:1 sec

4. On the U3661, press as follows to tune pre-selector.

MARKER, NEXT and AUTO PRESEL PK

5. After pre-selector tuning has completed, adjust signal generator output level so that the trace peak meets 5 divisions below the reference level.

6. On the U3661, press as follows to set single sweep.

MENU, SWEEP MODE and SINGLE SWEEP

7. After single sweep has completed, press **PEAK** to capture the signal peak.

3. PERFORMANCE VERIFICATION

8. Record the level of peak search marker reading as the reference value on the performance verification test record sheets.
9. Increment input attenuator by 10dB.
10. On the U3661 press as follows to set single sweep.

MENU, SWEEP MODE and SINGLE SWEEP

11. After single sweep has completed, press **PEAK** to capture the signal peak.
12. Read the level of the peak search marker reading.
13. Calculate the actual switching error reference value by following formula.
And record the result on the performance verification test record sheets.

Actual Marker reading =

(Reference Value measured in step8) - (Marker level measured in the step 9) - (IF gain error)

14. Repeat steps 9 through 13 for each attenuation setting listed in Table 3-10.

Table 3-10 Setting for Input Attenuator Switching Accuracy Test

Center Frequency	Attenuator	Reference Level	IF Gain
4 GHz	10 dB	0 dBm	0 dB
	20 dB	-10 dBm	10 dB
	30 dB	-20 dBm	20 dB
	40 dB	-30 dBm	30 dB
	50 dB	-40 dBm	40 dB
15 GHz	10 dB	0 dBm	0 dB
	20 dB	-10 dBm	10 dB
	30 dB	-20 dBm	20 dB
	40 dB	-30 dBm	30 dB
	50 dB	-40 dBm	40 dB
18 GHz	10 dB	0 dBm	0 dB
	20 dB	-10 dBm	10 dB
	30 dB	-20 dBm	20 dB
	40 dB	-30 dBm	30 dB
	50 dB	-40 dBm	40 dB

3. PERFORMANCE VERIFICATION

3.2.8. Scale Fidelity

Description

The 10 dB/div, 1 dB/div, and linear scales are tested for fidelity. The 1 dB/div scale is tested in RBW setting of 1 MHz.

The 10 dB/div scale is tested in RBW setting of 3 kHz.

A signal is set to the reference level for each scale. As the signal amplitude is decreased using external step attenuator, the displayed signal amplitude is compared to the reference level.

Specification

Log Scale Fidelity	:±0.2dB/1dB :± 1.0 dB/ 10 dB
Linear Scale Fidelity	:± 5% of reference level

Equipment used

Signal Generator	:SG4
1dB Step Attenuator	:ATT1
10dB Step Attenuator	:ATT2
Attenuator/Switch Driver	:HP11713A
RF Cable	:BNC(m)-BNC(m)
Adapter	:N (m)-BNC (f)

Setup

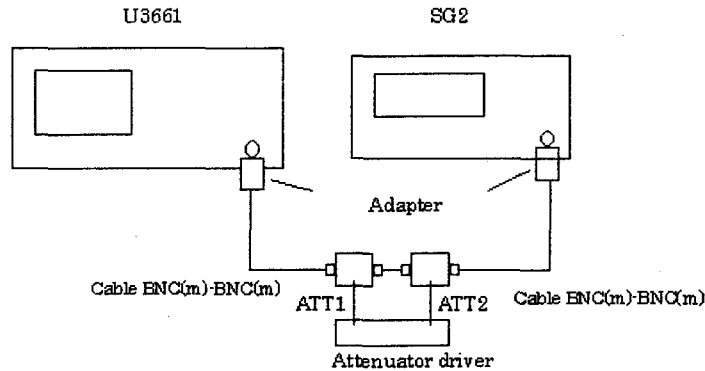

Figure 3-9 Setup for Scale Fidelity Test

Procedures:

1. Connect equipment as shown Figure 3-9.
2. On the SG4, set the controls as follows:

Frequency	:11MHz
Output Level	:0 dBm

3. On the U3661, after preset, set controls as follows:

Center Frequency	:11MHz
Span	:ZERO
Reference Level	:0dBm
RBW	:1MH
VBW	:10Hz
dB/div	:1 dB/div

4. On the ATT1 and ATT2, set the value to 0dB.
5. On the U3661, press **MKR** to put the marker on the trace.
6. On the U3661, press as follows to put display line at reference level.

MENU, DSP LINE ON/OFF (ON), 0, and dBm

3. PERFORMANCE VERIFICATION

7. On the SG4, adjust the output level so that the marker reading is $0.0\text{dBm} \pm 0.01\text{dB}$.
8. On the U3661, press as follows for single sweep.

MENU, SWEEP MODE and SINGLE SWEEP

9. On the ATT1, lower by 1dB.
10. On the U3661, press as follows for single sweep.

MENU, SWEEP MODE and SINGLE SWEEP

11. Record the level of fixed marker level in the Measured Data column in the performance verification test record sheets.

Calculate the incremental error by following formula and record the result in the Incremental Error in the column in the performance verification test record sheets.

$$\text{Incremental Error} = (\text{Current marker level}) - (\text{previous marker level}) + 1\text{dB}$$

12. Repeat steps 9 through 11 each value of external step attenuator is listed in the Table 3-11.

Table 3-11 Setting for 1 dB/div Scale Fidelity Test

RBW 1 MHz	Setting	Test Data
	External Attenuator(dB)	dB from reference Level
	0	0
	1	-1.0
	2	-2.0
	3	-3.0
	4	-4.0
	5	-5.0
	6	-6.0
	7	-7.0
	8	-8.0
	9	-9.0
	10	-10.0

3. PERFORMANCE VERIFICATION

13. On the U3661, after preset, set controls as follows:

Center Frequency	:11MHz
Span	:ZERO
Reference Level	:0dBm
RBW	:3kHz
VBW	:10Hz
dB/div	:10 dB/div

14. On the U3661, set the to 0dB.

15. On the U3661, press **MKR** to put marker on the trace.

16. 16. On the U3661 press as follows to put display line at reference level.

MENU, DSP LINE ON/OFF (ON), 0, and dBm

17. On the SG4, adjust the output level so that the marker reading is $0.0\text{dBm} \pm 0.01\text{dB}$.

18. On the U3661, press as follows for single sweep.

MENU, SWEEP MODE and SINGLE SWEEP

19. On the ATT2, lower by 10dB.

20. On the U3661, press as follow for single sweep.

MENU, SWEEP MODE and SINGLE SWEEP

21. Record the level of fixed marker level in the Measured Data column in the performance verification test record sheets.

Calculate the incremental error by following formula and record the result in the Incremental Error in the column in the performance verification test record sheets.

$$\text{Incremental Error} = (\text{Current marker level}) - (\text{previous marker level}) + 10\text{dB}$$

22. Repeat steps 19 through 21 for each value of external step attenuator is listed in the Table 3-12.

3. PERFORMANCE VERIFICATION

Table 3-12. Setting for 10dB/div Scale Fidelity Test

Setting		Test Data
RBW	External Attenuator(dB)	dB from Reference Level
3 kHz	0	0
	10	-10
	20	-20
	30	-30
	40	-40
	50	-50
	60	-60
	70	-70
	80	-80
	90	-90

[Linear Scale Fidelity]

23. On the SG4, set controls as follows:

Frequency :11MHz
 Output Level :0 dBm

24. On the ATT1 and ATT2, set the value to 0dB.

25. On the U3661, after preset, set controls as follows:

Center Frequency :11MHz
 Span :10kHz
 Reference Level :0dB
 RBW :1kHz
 VBW :1kHz
 Attenuator :20 dB

26. On the U3661, press as follows, to set vertical display mode to Linear.

REF LEVEL, *Linear*

27. On the U3661, press as follows to set continuous peak search mode.

MKR, *Peak, NEXT, Continuous Peak (ON/OFF) ON*

28. On the SG4, precisely set output level to the U3661 reference level while reading the marker level on the screen.

29. On the U3661, press as follows for single sweep.

MENU, *SWEEP MODE* and *SINGLE SWEEP*

3. PERFORMANCE VERIFICATION

30. Read the level value displayed on the SG4 and set the value as the reference value (Ref.).
31. Then set level of SG4 level to the 0.92dB lower than the reference value.
32. On the U3661, press as follows for single sweep.

MENU, SWEEP MODE and SINGLE SWEEP

33. Read the marker level and record it in the performance verification test record sheets.
34. Repeat steps 31 through 33 for each value listed in Table 3-13.

Table 3-13. Setting for Linear Scale Fidelity Test

Input Signal Level		Division from Reference Level
dB, Nominal	mV, Nominal	
0	223.60	0
-0.92	201.24	1
-1.94	178.88	2
-3.10	156.52	3
-4.44	134.16	4
-6.02	111.80	5
-7.96	89.44	6
-10.46	67.08	7
-19.98	44.72	8
-20.00	22.36	9

3.2.9. Residual FM**Description**

This test measures the inherent short-term instability of the spectrum analyzer. A stable signal is applied to the spectrum analyzer input. The analyzer is set to zero span and the signal is slope detected on the skirt of the RBW. Any instability in the spectrum analyzer's Local Oscillator system is transferred to the IF in the mixing process. The test determines the slope of IF filter in Hz/dB and measures the signal amplitude variation caused by the residual FM. Multiplying these two values residual FM in Hz.

Specification

Residual FM: $\leq 60 \text{ Hzp-p}/0.1 \text{ sec.}$

3. PERFORMANCE VERIFICATION

Equipment used

Signal Generator	:SG2
RF Cable	:SMA(m)-SMA(m)
RF Cable	:BNC(m)-BNC(m)
Adapter	:N (m)-BNC (f)

Setup

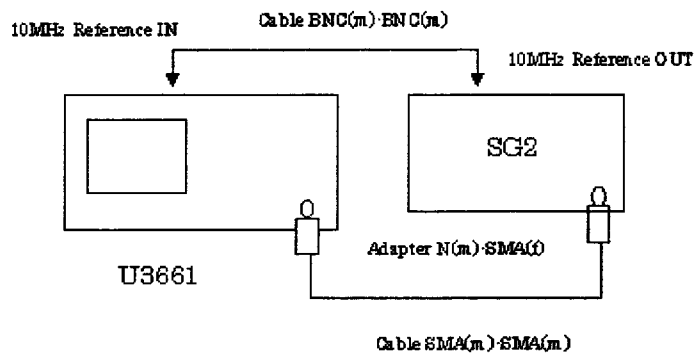

Figure 3-10 Setup of Residual FM Test

Procedure

[Determining the IF filter slope]

1. Connect the equipment as shown in Figure 3-10.
2. On the SG2, set controls as follows:

Frequency	:2.5GHz
Output Level	:-10 dBm

3. On the U3661, after preset, set controls as follows:

Center Frequency	:2.5GHz
Span	:100 kHz

4. On the U3661, press **PEAK** to capture the signal peak.

3. PERFORMANCE VERIFICATION

5. On the U3661, press as follow to set signal track mode to on.

MKR, Signal Track ON/OFF (ON)

6. On the U3661, set controls as follows:

Span	:5kHz
RBW	:1 kHz

7. On the U3661, press as follows to set signal track mode to off.

MKR, Signal Track ON/OFF (OFF)

8. On the U3661, set controls as follows:

Reference Level	:-15dBm
dB/div	:1dB/div
Span	:1kHz
VBW	:100Hz
CF Step	:10 Hz

9. On the U3661, press as follows to set marker at the center frequency.

MKR, (Center Frequency data on the screen), MHz

10. On the U3661, press CENTER and rotate data knob clockwise until the marker reads -20 dBm, or about 5 divisions below reference level.
11. On the U3661, press as follows for single sweep.

MENU, SWEEP MODE and SINGLE SWEEP

12. On the U3661, rotate data knob clockwise until the marker reads $-16 \text{ dB} \pm 0.1 \text{ dB}$, or about 1 division below reference level.
13. On the U3661, press as follows to set delta marker mode to on.

MKR, Δ Marker

14. On the U3661, rotate data knob clockwise until marker reads $-8 \text{ dB} \pm 0.1 \text{ dB}$, or about 8 divisions below reference level.
15. Record the frequency and the level of the delta marker reading on the performance verification test record sheets.

3. PERFORMANCE VERIFICATION

16. Calculate the slope using the following formula on the performance verification test record sheets.

$$\text{Slope} = (\text{the frequency of the delta marker reading}) / (\text{the level of the delta marker reading})$$

[Measuring Residual FM]

17. On the U3661, press **CONT SWEEP** for continuous sweep.
18. On the U3661, set controls as follows:

Span	:ZERO
Sweep Time	:100msec
CF Step MNL	:10 Hz

19. On the U3661, press **CENTER** and rotate data knob clockwise to place trace displayed peak about 5 divisions below reference level.
20. On the U3661, press as follows for single sweep.

MENU, SWEEP MODE and SINGLE SWEEP

21. On the U3661, press as follows to set peak search and delta marker mode.

PEAK, MKR, Delta Marker

22. On the U3661, press as follows to capture minimum peak signal.

PEAK, Min Peak

23. Record the level of delta marker reading as Delta Level on the performance verification test record sheets.

[Calculation residual FM]

24. Calculate the Residual FM using the following formula,

$$\text{Residual FM [Hz]} = \text{Slope [Hz/dB]} \times \text{Delta Level[dB]}$$

Record the result on the performance verification test record sheets.

3.2.10. Noise Sidebands

Description

The noise sidebands of a 1.0GHz, 0dBm signal is measured at offset of 10 kHz and 20 kHz from the carrier.

The noise marker (dBc/Hz) and averaging functions are used to average the noise sidebands at each offset.

Specification

Frequency ≤ 7.1 GHz: ≤ -105 dBc/ Hz at 20 kHz offset

Frequency > 6.7 GHz: $\leq (-105 + 20\log N)$ dBc/Hz at 20 kHz offset

Frequency ≤ 7.1 GHz: ≤ -100 dBc/Hz at 10 kHz offset

Frequency > 6.7 GHz: $\leq (-100 + 20\log N)$ dBc/Hz at 10 kHz offset

Equipment used

Signal Generator	:SG3
RF Cable	:SMA(m)-SMA(m)
RF Cable	:BNC(m)-BNC(m)
Adapter	:N (m)-SMA (f)

Setup

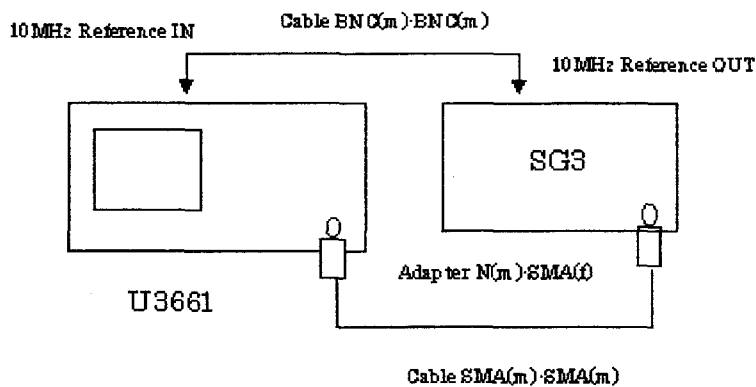

Figure 3-11 Setup of Noise Sidebands Test

3. PERFORMANCE VERIFICATION

Procedure

1. Connect equipment as shown in Figure3-11.
2. On the SG1, set controls as follows:

Frequency :1GHz
 Output Level :-5 dBm

3. On the U3661, after preset, set controls as follows:

Center Frequency :1GHz
 Span :50 kHz

4. On the U3661, press as follows to set noise marker mode to on:

PEAK, MKR →, MKR →REF, PEAK, MARKER, NOISE/XHz, 1 Hz and dBc/Hz

5. On the U3661, put the noise marker at 10 kHz offset frequency using data knob or press **1,0, kHz**.
6. On the U3661, set the reference level by 20dB and press as follows to perform averaging for 20 samples:

TRACE, AVERAGE, 2, 0, Hz

7. Record the level of marker reading on the performance verification test record sheets.
8. Repeat steps 5 through 7 for each offset frequency setting listed in Table 3-14

Table3-14 Setting for Noise Sidebands Test

Center Frequency(Hz)	Span(Hz)	Offset Frequency(Hz)
1 G	50 k	10 k
	50 k	20 k

3.2.11. Image, Multiple, and Out-of-Band Responses

Description

Image, multiple, and out-of-band responses are tested in all frequency bands. A signal is applied to the signal analyzer's INPUT 50Ω , and then a reference amplitude measurement is made. The signal source is then tuned to a frequency which causes either an image, multiple, or out-of-band response. The amplitude displayed on the spectrum analyzer is measured and recorded.

Specification

< -50 dBc: Frequency Range 10MHz to 26.5 GHz

Equipment used

Signal Generator	:SG2
RF Power Meter	:P.M
RF Power Sensor	:P.S
Power Splitter	:1579
RF Cable	:SMA(m)-SMA(m)
Adapter	:SMA (m)-SMA (f)

Setup

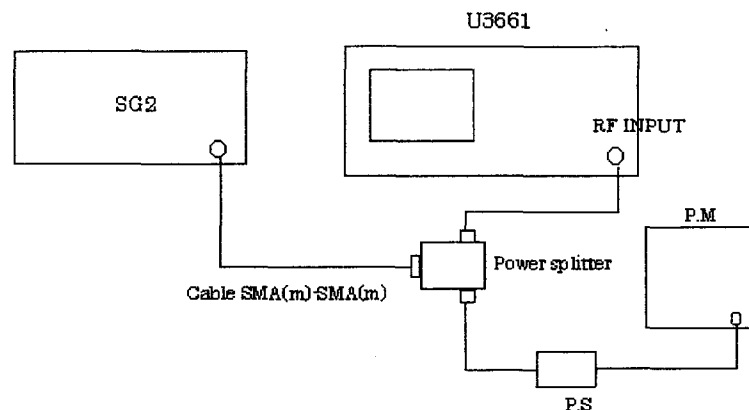

Figure 3-12 Setup of a Image, Multiple, Out of Band Responses Test

3. PERFORMANCE VERIFICATION

Procedure

1. On the P.M, perform the zeroing and calibration with P.S.

Set into dBm mode, after calibration has completed.

2. On the P.M, set a correction data to 1 GHz.
3. Connect equipment as shown Figure 3-12.
4. On the SG2, set controls as follows:

Frequency	:1GHz
Output Level	:0 dBm

5. On the U3661, after preset, set controls as follows:

Center Frequency	:1GHz
Span	:5MHz
RBW	:100kHz
VBW	:300 Hz

6. On the SG2, adjust the output level so that P.M reading is $0\text{dBm} \pm 0.1\text{dB}$.
7. On the U3661, press as follows for single sweep.

MENU, SWEEP MODE and SINGLE SWEEP

8. On the U3661, after single sweep has completed, press **PEAK** to capture signal peak.
9. On the U3661, press as follows to set fixed marker to on.

MKR, Delta Marker, Fixed Marker ON/OFF (ON)

10. On the U3661, press **CONT SWEEP** for continuous sweep.
11. On the SG2, set control as follow:

Frequency	:1.442800 GHz
-----------	---------------

12. On the P.M, set the correction data to 1.44 GHz
13. On the U3661, press as follows for single sweep.

MENU, SWEEP MODE and SINGLE SWEEP

14. On the U3661, after single sweep has completed, press **PEAK** to capture signal peak.
15. Record the delta marker reading on the performance verification test record sheets.
16. Repeat steps 10 through 15 for each frequency listed in Table 3-15.

Table 3-15 Setting for Image, Multiple, Out of Band Response Test

Center Frequency of u3661	Frequency of SG2	Correction Data for P.M
1.0 GHz	1.110700 GHz	1.11 GHz
	9.122800 GHz	9.12 GHz
	7.092100 GHz	7.09 GHz
	19.245600 GHz	19.25 GHz
5.5 GHz	5.942800 GHz	5.94 GHz
	11.221400 GHz	11.22 GHz
	16.942800 GHz	16.94 GHz
	22.664200 GHz	22.66 GHz
11.0 GHz	11.442800 GHz	11.44 GHz
	5.389300 GHz	5.39 GHz
	16.610700 GHz	16.61 GHz
	22.221400 GHz	22.22 GHz
24.0 GHz	24.442800 GHz	24.44 GHz
	5.833950 GHz	5.83 GHz
	11.889300 GHz	11.89 GHz
	17.944650 GHz	17.94 GHz

3.2.12. Accuracy of Frequency Readout and Frequency Count Marker

Description

The accuracy of the spectrum analyzer frequency readout and frequency count marker is tested with an input signal of known frequency.

Test at the points 2GHz, 5GHz, 11GHz and 18GHz.

For the points of frequencies above 5GHz are required to tune pre-selector peak.

Specification

Accuracy of Frequency Readout

$$\pm (\text{Center Frequency} \times \text{Frequency Reference Accuracy} + \text{Frequency span} \times \text{Frequency Span Accuracy} + 0.15 \times \text{Resolution band width} + 60\text{Hz} \times \text{N})$$

Span Accuracy $< \pm 5 \%$

Accuracy of Frequency Counter Marker

$$\pm (\text{Marker Frequency} \times \text{Frequency Reference Accuracy} + 5 \text{ Hz} \times \text{N} + 1 \text{ LSD})$$

Span < 200MHz: S/N >25 dB

N: Band

3. PERFORMANCE VERIFICATION

Equipment used

Frequency Standard	:Freq.STD
Signal Generator	:SG2
RF Cable	:BNC(m)-BNC(m)
RF Cable	:SMA(m)-SMA(m)
Adapter	:N (m)-SMA (f)

Setup

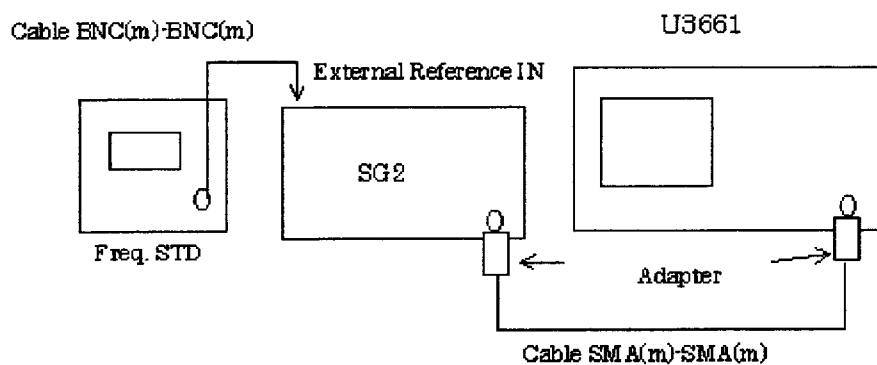

Figure 3-13 Setup of a Frequency Readout Accuracy and Frequency Counter Marker Test

Procedures:

1. Connect equipment as shown in Figure 3-13.

2. On the SG2, set controls as follows:

Frequency	:2GHz
Output Level	:-10dBm
10MHz Reference	:External

3. On the U3661, after preset, set controls as follows:

Center Frequency	:2GHz
Span	:1MHz
RBW	:10 kHz

4. Above frequency 5 GHz on the U3661, press as follows to tune pre-selector peak.

MARKER, NEXT, AUTO Presel PK

3. PERFORMANCE VERIFICATION

5. On the U3661, after tuning has completed, press as follows for single sweep.

MENU, SWEEP MODE and SINGLE SWEEP

- 6. On the U3661, after single sweep has completed, press **PEAK** to capture signal peak.
- 7. Record the frequency of marker reading on the performance verification test record sheets.
- 8. Repeat steps 2 through 7 for each frequency setting listed in Table 3-16.

Table 3-16 Setting for Frequency Readout Accuracy Test

Setting of Signal Generator	Setting of U3661		
Frequency	Center Frequency	Span	RBW
2 GHz	2 GHz	1 MHz	10 kHz
		10 MHz	100 kHz
		20 MHz	300 kHz
		50 MHz	300 kHz
		100 MHz	1 MHz
		2 GHz	3 MHz
5 GHz	5 GHz	1 MHz	10 kHz
		10 MHz	100 kHz
		20 MHz	300 kHz
		50 MHz	300 kHz
		100 MHz	1 MHz
		2 GHz	3 MHz
11 GHz	11 GHz	1 MHz	10 kHz
		10 MHz	100 kHz
		20 MHz	300 kHz
		50 MHz	300 kHz
		100 MHz	1 MHz
		2 GHz	3 MHz
18 GHz	18 GHz	1 MHz	10 kHz
		10 MHz	100 kHz
		20 MHz	300 kHz
		50 MHz	300 kHz
		100 MHz	1 MHz
		2 GHz	3 MHz

[Frequency Counter Marker Accuracy]

9. On the SG2, set controls as follows:

Frequency :2GHz
 Output Level :-10dBm
 10 MHz Reference :External

10. On the U3661, set controls as follows:

Center Frequency :2GHz
 Span :1 MHz

3. PERFORMANCE VERIFICATION

11. Above frequency 5 GHz on the U3661 press as follows to tune pre-selector peak.

MARKER, NEXT, AUTO Presel PK

12. On the U3661, press as follows to set frequency counter mode.

MEAS1, Counter, CNT RES and 1 Hz

13. On the U3661, press as follows for single sweep.

MENU, SWEEP MODE and SINGLE SWEEP

14. On the U3661, press **PEAK** to capture signal peak.

15. Record the frequency of the frequency counter reading on the performance verification test record sheets.

16. Repeat steps 9 through 15 for each setting listed on Table 3-17.

Table 3-17 Setting for Frequency Counter Marker Accuracy

Setting of Signal Generator	Setting of U3661	
	Center Frequency	Span
2 GHz	2 GHz	200 MHz
5 GHz	5 GHz	200 MHz
11 GHz	11 GHz	200 MHz
18 GHz	18 GHz	200 MHz

3.2.13. Second Harmonic Distortion

Description

A synthesized signal generator and low-pass filter provide the signal for measuring second harmonic distortion. The low-pass filter eliminates any harmonic distortion originating at the signal source. The U3661 frequency response is calibrated.

The U3661 is phase-locked to the signal generator's 10MHz reference.

Test will be done the points of 1.5 GHz and 1.9 GHz as fundamental signal.

To measure second harmonics distortion, use Fixed Marker in Delta Marker function.

Specification

- < -70dBc:(Fundamental Frequency 10 MHz to 1.7 GHz, -30 dBm mixer input level)
- < -100 dBc:(Fundamental Frequency 1.7GHz to 3.2 GHz, -10dBm mixer input level)
- < -100 dBc: (Fundamental Frequency > 3.2 GHz, -10 dBm mixer input level)

Equipment used

Signal Generator	:SG1
RF Power Meter	:P.M
RF Power Sensor	:P.S
Power Splitter	:1579
2 GHz Low-pass Filter	:DEE-001172-1
RF Cable	:SMA(m)-SMA(m)
RF Cable	:BNC(m)-BNC(m)
Adapter	:N (m)-SMA (f)

Setup

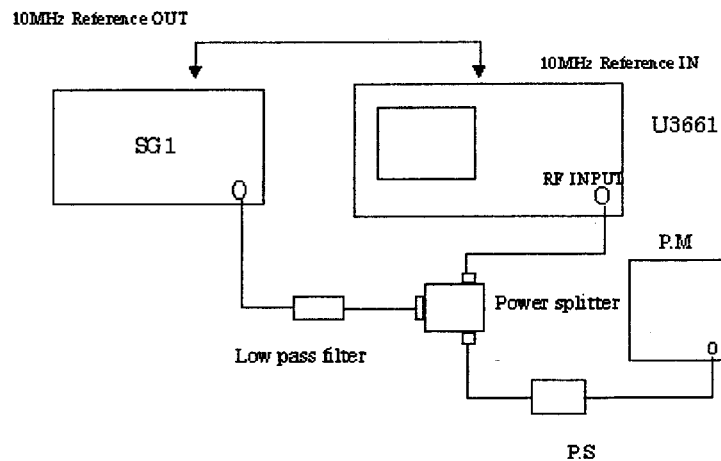

Figure 3-14 Setup of a Second Harmonics Distortion Test

Procedure

1. On the P.M, perform the zeroing and calibration with P.S.

Set into dBm mode, after calibration has done.

2. On the P.M, set a correction data to 1.5 GHz
3. Connect equipment as shown in Figure 3-14.
4. On the SG1, set controls as follows;

Frequency	:1.5GHz
Output Level	:0dBm
10MHz Reference	:External

3. PERFORMANCE VERIFICATION

5. On the U3661, after preset, set controls as follows:

Center Frequency	:1.5GHz
Span	:10kHz
Attenuator	:20dB
Reference Level	:-10dBm
VBW	:30 Hz

6. On the SG1, adjust output level so that the P.M reading is $-10\text{dBm} \pm 0.09\text{dB}$.

7. On the U3661, press as follows for single sweep.

MENU, SWEEP MODE and SINGLE SWEEP

8. On the U3661, after single sweep has completed, press **PEAK** to capture signal peak.

9. On the U3661, press as follows to set fixed marker to on. to ON.

MKR, Delta Marker, Fixed Marker ON/OFF (ON)

10. On the U3661, set center frequency to 3 GHz.

11. On the U3661, press as follows for single sweep.

MENU, SWEEP MODE and SINGLE SWEEP

12. On the U3661, press **PEAK** to capture signal peak.

13. Record the level of the delta marker reading on the performance verification test record sheets.

[Measurement for 3.2 GHz or higher band]

14. Remove the low-pass filter and connect the RF cable between SG1 and the U3661.

15. On the SG1, set controls as follows:

Frequency	:3.8GHz
Output Level	:-10 dBm

16. On the U3661, set controls as follows:

Center Frequency	:3.8GHz
Span	:500 kHz

17. On the U3661, press as follows to tune pre-selector peak.

PEAK, MARKER, NEXT and AUTO PRESEL PK

3. PERFORMANCE VERIFICATION

18. On the U3661, after auto tuning has completed, set SG1 controls as follows:

Frequency :1.9GHz
Output Level :0 dBm

19. Reconnect SG1 as shown Figure 14.

20. On the P.M, set the correction data to 1.9GHz.

21. On the SG1, adjust output level so that P.M reading is $-10 \text{ dBm} \pm 0.09 \text{ dB}$.

22. On the U3661, set controls as follows;

Center Frequency :1.9GHz
Span :1 kHz

23. On the U3661, press as follows to set fixed marker mode to on.

MKR, Delta Marker, Fixed Marker ON/OFF (ON)

24. On the U3661, set controls as follows:

Center Frequency :3.8GHz
Reference Level :-40 dBm

25. On the U3661, press as follows to set average mode for 20 samples.

TRACE, Average, 2,0 and Hz (ENTER)

26. On the U3661, after average has completed, press **PEAK** to capture signal peak.

27. Record the level of the delta marker reading on the performance verification test record sheets.

3. PERFORMANCE VERIFICATION

3.2.14. Frequency Response

Description

The output of the signal generator is fed through a power splitter to a power sensor, then to the spectrum analyzer. The signal generator's power level is adjusted at 30 MHz to place the displayed signal at the center horizontal graticule line of the spectrum analyzer. The power meter is placed in relative mode. At each new signal generator frequency and spectrum analyzer center frequency, the signal generator's power level is adjusted to place the signal at the center horizontal graticule line. The RF power meter displays the inverse of the frequency response relative to the signal of CAL OUT.

The U3661 is phase locked to the signal generator's 10 MHz reference.

The test will be done for both pre-amplifier on and off condition.

Specification

After auto calibration and preselector peaked

Pre-amplifier Off

(at Input attenuator: 10 dB, referenced to 30 MHz)

± 1.0 dB, Frequency Range: 100 kHz to 2.7 GHz

± 2.0 dB, Frequency Range: 9 kHz to 3.2 GHz

± 1.5 dB, Frequency Range: 3 GHz to 7.1GHz

± 3.5 dB, Frequency Range: 6.7 GHz to 14.5 GHz

± 4.0 dB, Frequency Range: 13.7 GHz to 26.5 GHz

Pre-amplifier On

(Input attenuator 0 dB, referenced to 30 MHz)

± 1.0 dB Frequency Range: 100 kHz to 2.7 GHz

± 2.0 dB Frequency Range: 9 kHz to 3.2 GHz

Equipment used

Signal Generator	:SG2
RF Power Meter	:P.M
RF Power Sensor	:NRVZ52
Power Splitter	:1579
RF Cable	:SMA(m)-SMA(m)
RF Cable	:BNC (m)-BNC (m)

Setup

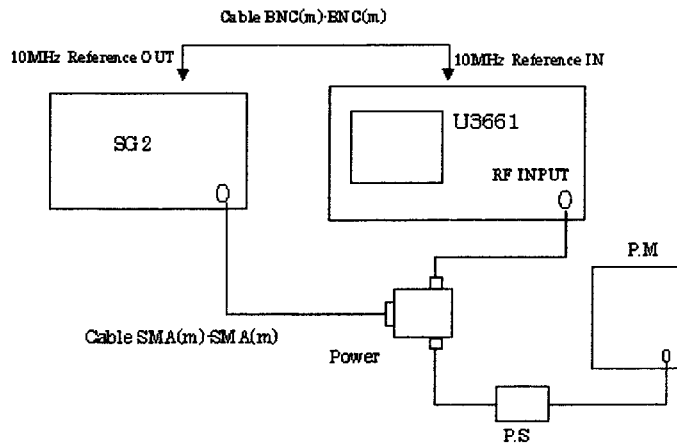

Figure 3-15 Setup of Frequency Response Test

Procedure

[Pre-amplifier Off condition]

1. Perform the zeroing and calibration of RF Power Meter with RF Power Sensor.
Set into dBm mode, after calibration has done.
2. Connect equipment as shown in Figure 3-15.
3. On the SG2, set controls as follows:

Frequency	:30MHz
Frequency Step	:100MHz
Output Level	:-4 dBm

4. On the U3661, after preset, set controls as follows:

Center Frequency	:30MHz
Center Frequency Step	:100MHz
Span	:40MHz
Reference Level	:-5dBm
dB/div	:1dB/div
RBW	:3MHz
VBW	:1 kHz

3. PERFORMANCE VERIFICATION

5. On the U3661, press as follows to set continuous peak search mode.

PEAK, NEXT and CONT PK ON

6. Adjust signal generator output level so that reading of peak search marker is $-10\text{dBm} \pm 0.09\text{dB}$.

7. On the RF power meter, set correction data for 30MHz and relative measurement mode.

[Measuring frequency response in the frequency range: 9 kHz to 3.2GHz]

8. Set frequency of SG2 to 100 MHz.
9. On the U3661, set center frequency to 100 MHz.
10. On the RF power meter, set correction data for 100 MHz.
11. Adjust output level of SG2 so that reading of peak search marker is $-10\text{ dBm} \pm 0.09\text{ dB}$.
12. Record the display of RF power meter reading with reverse sign in performance verification test record sheets.
13. On the U3661, press **CENTER** and Δ to increase center frequency by 100 MHz step.
14. On the SG2, increment the frequency of output by 100 MHz.
15. On the RF power meter, set the correction data for the frequency by 100 MHz step.
16. Repeat steps 11 through 15 for every center frequency by 100 MHz step up the center frequency to 3.2 GHz listed in performance verification test record sheets.

[Measuring frequency response in the frequency range 3.0 GHz to 7.1 GHz]

For testing this frequency range, pre selector tune is required.

17. On the U3661, set center frequency to 3.1 GHz.
18. On the SG2, set the frequency to 3.1 GHz.
19. On the RF power meter set the correction data for 3.1 GHz.
20. On the U3661, press as follows to tune the pre selector peak.

MARKER, NEXT and AUTO PRESEL PK

21. After the auto tuning has completed, adjust SG2 output level so that the marker reading is $-10.0\text{dBm} \pm 0.09\text{dB}$.
22. Record the display of RF power meter reading with reverse sign in performance verification test record sheets.
23. On the U3661, press **CENTER** and Δ to set center frequency by 100 MHz step.
24. On the SG2, increment the frequency of output by 100 MHz.
25. On the RF power meter, set the correction data for the frequency by 100 MHz step.
26. Repeat steps 20 through 25 for every center frequency by 100 MHz step up the center

frequency to 7.1 GHz listed in performance verification test record sheets.

[Measuring frequency response in the frequency range 6.7 GHz to 14.5 GHz]

For the frequency range, verify frequency response by 200 MHz step.

27. On the U3661, set CF step size to 200 MHz.
28. On the U3661, set center frequency to 14.5 GHz at first, then set it to 6.8 GHz.
29. On the SG2, set the frequency of output to 6.8 GHz.
30. On the RF power meter, set the correction data for 6.8 GHz.
31. On the U3661, press as follows to tune the pre selector peak.

MARKER, NEXT and AUTO PRESEL PK

32. After the auto tuning has completed, adjust SG2 output level so that the marker reading is $-10.0 \text{ dBm} \pm 0.09 \text{ dB}$.
33. Record the display of RF power meter reading with reverse sign in performance verification test record sheets.
34. On the U3661, press **CENTER** and Δ to set center frequency by 200 MHz step.
35. On the SG2, increment the frequency of output by 200 MHz.
36. On the RF power meter, set the correction data for the frequency by 200 MHz step.
37. Repeat steps 31 through 36 for every center frequency by 200 MHz step up the center frequency to 14.5 GHz listed in performance verification test record sheets.

[Measuring frequency response in the frequency range 13.7 GHz to 26.5 GHz]

38. On the U3661, set center frequency to 26.5 GHz at first, then set it to 13.8 GHz.
39. On the SG2, set the frequency of output to 13.8 GHz.
40. On the RF power meter, set the correction data for 13.8 GHz.
41. On the U3661, press as follows to tune pre selector peak.

MARKER, NEXT and AUTO PRESEL PK

42. After the auto tuning has completed, adjust SG2 output level so that the marker reading is $-10.0 \text{ dBm} \pm 0.09 \text{ dB}$.
43. Record the display of RF power meter reading with reverse sign in performance verification test sheets.
44. On the U3661, press **CENTER** and Δ to set center frequency by 200 MHz step.
45. On the SG2, increment the frequency of output by 200MHz.
46. On the RF power meter, set the correction data for the frequency by 200 MHz step.
47. Repeat steps 41 through 46 for every center frequency by 200 MHz step up the center frequency to 25.6 GHz listed in performance verification test record sheets.

3. PERFORMANCE VERIFICATION

[Pre-amplifier Off Condition]

48. On the SG2, set the SG2 controls as follows:

Frequency	:30MHz
Frequency Step	:100MHz
Output Level	:-4 dBm

49. On the U3661, after preset, set controls as follows:

Center Frequency	:30MHz
Center Frequency Step	:100MHz
Span	:40MHz
Attenuator	:0dB
Reference Level	:-5dBm
dB/div	:1dB/div
RBW	:3MHz
VBW	:1kHz
Pre-AMP	:ON

50. Repeat steps 5 through 16 for each frequency listed in performance verification test record sheets.

3.2.15. Frequency Span Accuracy

Description

Set the signal frequency twice with the signal generator and measure the difference between signal frequencies with the analyzer.

Check the span accuracy using the signal frequency difference measured with the delta marker function.

The U3661 is phase-locked to the signal generator's 10MHz reference.

Specification

< ± 3 % of the frequency span setting.

Equipment used

Signal Generator	:SG2
RF Cable	:SMA(m)-SMA(m)
RF Cable	:BNC(m)-BNC(m)
Adapter	:N (m)-SMA (f)

Setup

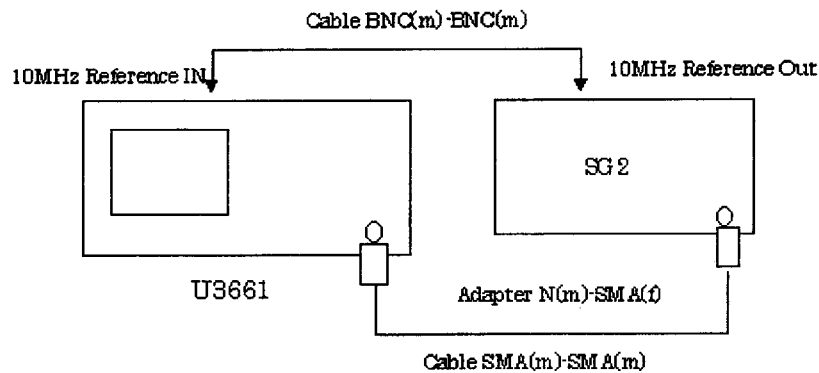

Figure 3-16 Setup of a Frequency Span Accuracy Test

Procedures:

1. Connect equipment as shown in Figure 3-16.
2. On the SG2, set controls as follows:

Output Level	: -5dBm
10 MHz Reference	: External

3. On the U3661, preset.
4. On the SG2, set controls as follow for 1st frequency.

Frequency	: 1.999992 GHz
-----------	----------------

5. On the U3661, set controls as follows:

Center Frequency	: 2GHz
Span	: 20 kHz

3. PERFORMANCE VERIFICATION

6. On the U3661, press as follows for single sweep.

MENU, SWEEP MODE and SINGLE SWEEP

7. On the U3661, after sweep has completed, press **PEAK** to capture signal peak.

8. On the U3661, press as follows to set delta marker to on.

MKR, Delta Marker

9. On the SG2, set output frequency as follow for 2nd frequency.

Frequency :2.000008 GHz

10. On the U3661, press as follows for single sweep.

MENU, SWEEP MODE and SINGLE SWEEP

11. On the U3661, after sweep has completed, press **PEAK** to capture signal peak.

12. Record the frequency of delta marker on the performance verification test record sheets.

13. Repeat steps 4 through 12 for each frequency setting listed in Table 3-18.

Table 3-18 Setting for Center and Span Frequencies for Span Accuracy Test

Signal Generator		U3661	
1st Frequency	2nd Frequency	Center Frequency	Span
1.99980 GHz	2.000020 GHz	2 GHz	50 kHz
1.999940 GHz	2.000160 GHz	2 GHz	400 kHz
1.9992 GHz	2.0008 GHz	2 GHz	2 MHz
1.9992 GHz	2.0008 GHz	2 GHz	2.01 MHz
1.998 GHz	2.002 GHz	2 GHz	5 MHz
1.996 GHz	2.004 GHz	2 GHz	10 MHz
1.992 GHz	2.008 GHz	2 GHz	20 MHz
1.98 GHz	2.02 GHz	2 GHz	50 MHz
1.96 GHz	2.04 GHz	2 GHz	100 MHz
1.92 GHz	2.08 GHz	2 GHz	200 MHz
1.8 GHz	2.2 GHz	2 GHz	500 MHz
1.6 GHz	2.4 GHz	2 GHz	1 GHz
1.2 GHz	2.8 GHz	2 GHz	2 GHz
2.9 GHz	6.1 GHz	4.5 GHz	4 GHz
1.3 GHz	7.7 GHz	4.5 GHz	8 GHz
9.996 GHz	10.004 GHz	10 GHz	10 MHz
9.96 GHz	10.04 GHz	10 GHz	100 MHz
9.6 GHz	10.4 GHz	10 GHz	1 GHz
9.2 GHz	10.8 GHz	10 GHz	2 GHz
16.996 GHz	17.004 GHz	17 GHz	10 MHz
16.96 GHz	17.04 GHz	17 GHz	100 MHz
16.6 GHz	17.4 GHz	17 GHz	1 GHz
16.2 GHz	17.8 GHz	17 GHz	2 GHz
8 GHz	12 GHz	10 GHz	5 GHz
6 GHz	14 GHz	10 GHz	10 GHz
2 GHz	18 GHz	10 GHz	19 GHz

3.2.16. Third Order Intermodulation Distortion

Description

Two Signal generators provide the signals required for measuring third order intermodulation.

It is difficult when the input level is low because of being buried to the noise, to measure the spectrum generated by the distortion. Third ordered inter-modulation is raised by 20 dB if the input level is raised by 10 dB. Then, examine with mixer input level set in -20 dBm after the specification is converted into a value, which is 20dB larger. Here provides procedure at -20 dBm for a total mixer input level.

The test points of center frequencies are 20.5 MHz, 105 MHz, 1500 MHz, 2000 MHz , 3600 MHz and 8000 MHz.

Specification

Total mixer input level: -30 dBm, two signal difference > 10 kHz

< -70dBc

Equipment used

Signal Generator	:SG1
Signal Generator	:SG2
RF Power Meter	:P.M
RF Power Sensor	:P.S
Power Divider	:Divider1
Power Divider	:Divider2
RF Cable	:SMA(m)-SMA(m)
Adapter	:N(m)-SMA(f)
Adapter	:SMA (f)-SMA (f)

3. PERFORMANCE VERIFICATION

Setup

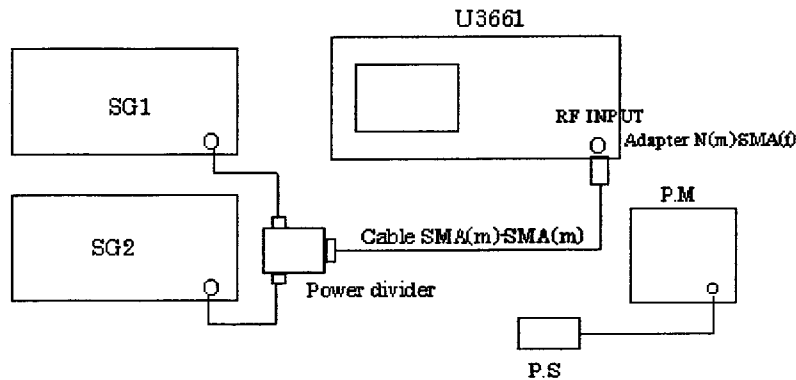

Figure 3-17 Setup of Third Order Intermodulation Test

Procedure

[Third Order Intermodulation (< 1GHz)]

1. On the P.M, perform the zeroing and calibration with P.S.
Set into dBm mode, after calibration has done.
2. On the P.M, set a correction data to 20.5 MHz.
3. Connect P.S to divider1 output.
4. On the both of signal generator, set controls as follows:

SG2

Frequency	:20.5MHz
Output Level	:-10dBm
RF Output	:Off

SG1

Frequency	:20.6MHz
Output Level	:-10dBm
RF Output	:Off

5. Turn RF output on of SG2.
6. On the SG2, adjust output level so that P.M reading is -10.0 dBm \pm 0.1 dB.
7. Turn RF output off of SG2, and turn RF output on of SG1.
8. On the SG1, adjust output level so that P.M reading is -10.0 dBm \pm 0.1 dB then turn RF output to off.

3. PERFORMANCE VERIFICATION

9. Remove P.S from divider, and then connect U3661 input as shown Figure 3-17.
10. On the U3661, after preset, set controls as follows:

Center Frequency :20.5MHz
 Span :1MHz
 Attenuator :10dB
 Reference Level :-10dBm
 RBW :3kHz
 VBW :300 Hz

11. Turn RF output on for both of signal generator.
12. On the U3661, this procedure is required for the frequency above 3.2 GHz.
 Press as follows to tune pre-selector peak.

MARKER, NEXT and AUTO PRESEL PK

13. On the U3661, after tuning has completed, press as follows to set signal peak to be reference level.

PEAK, MKR→ and Marker →Ref

14. On the U3661, press as follows to set 3rd order Measure mode.

MEAS2, 3rd Order Measure

15. Record the level of delta marker reading in dBc on the performance verification test record sheets.
16. Repeat steps 2 through 15 for each frequency setting listed in Table 3-19.

Table 3-19. Setting for Third Order Intermodulation Test

Frequency of SG1	Frequency of SG2	Setting of U3661		Correction Data for P.M	Power Divider Used
		Center Frequency	VBW		
105 MHz	105.1 MHz	105 MHz	300 Hz	105 MHz	Divider1
1500 MHz	1500.1 MHz	1500 MHz	300 Hz	1.5 GHz	Divider1
2000 MHz	2000.1 MHz	2000 MHz	100 Hz	2.0 GHz	Divider2
3600 MHz	3600.1 MHz	3600 MHz	100 Hz	3.6 GHz	Divider2
8000 MHz	8000.1 MHz	8000 MHz	100 Hz	8.0 GHz	Divider2

3. PERFORMANCE VERIFICATION

3.2.17. Gain Compression

Description

This test measures the analyzer's gain compression using two signals that are 1 MHz apart. First the test places a -30dBm signal at the input of the U3661 (the U3661's reference level is also set to -30dBm).

Then the specified signal level is input to the U3661, overdriving its input. The decrease in the first signal's amplitude (gain compression) caused by the second signal is the measured gain compression.

This test measures gain compression at the point of 10.5 MHz, 200.5 MHz, 3600.5 MHz and 3600.5MHz for pre-amplifier on condition.

Under pre-amplifier on condition, tests 10.5 MHz and 200.5 MHz.

The points of 3600.5MHz and 7600.5 MHz are required pre-selector tuning.

Specification:

< -10 dBm (mixer input level): Pre-Amplifier OFF

< -30 dBm (mixer input level): Pre-Amplifier ON

Equipment used

Signal Generator	:SG1
Signal Generator	:SG2
RF Power Meter	:P.M
RF Power Sensor	:P.S
Power Splitter	:1579
3 dB Attenuator	:ATT3
10 dB Attenuator	:ATT4
RF Cable	:SMA(m)-SMA(m)
Adapter	:N (m)-SMA (f)

Setup

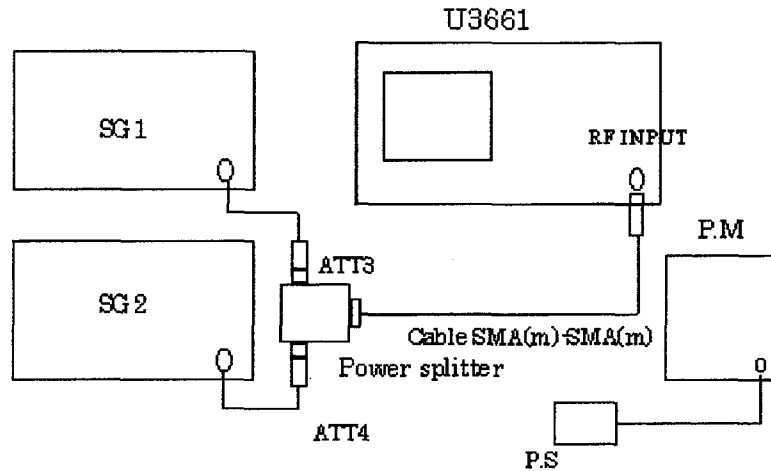

Figure 3-18 Setup of a Gain Compression Test

Procedure:

[Pre-amplifier OFF Condition]

1. Perform the zeroing and calibration of RF Power Meter with RF Power Sensor.
Set RF Power Meter into dBm mode, after calibration has done.
2. Connect equipment as shown in Figure 3-18.
3. On the both of signal generator, set controls as follows;

SG2

Frequency :11MHz
Output Level :-2 dBm

SG1

Frequency :10MHz
Output Level :-12 dBm

4. On the U3661, after preset, set controls as follows:

Center Frequency	:10.5MHz
Span	:2MHz
Attenuator	:0dB
Reference Level	:-30dBm
dB/div	:1 dB/div
5. On the SG1, turn output level off.

3. PERFORMANCE VERIFICATION

6. On the SG2, adjust the output level for a displayed signal of $-30 \text{ dBm} \pm 0.1 \text{ dB}$ on the U3661 screen.
7. On the SG1, turn output level on.
8. On the SG1, adjust output level until the signal level at 2.5 divisions in the left hand part on the U3661 screen is lowered by 1 dB from -30 dBm.
9. Remove the RF cable from the input terminal of U3661, connect RF power sensor there.
10. On the P.M, set correction data to 10.5MHz.
11. Record the level of the RF power meter reading on the performance test data sheets.
12. Repeat steps 3 through 11 for the center frequency 200.5 MHz, as the following setting.

SG1

Frequency :200 MHz

SG2

Frequency :201 MHz

U3661 Center Frequency :200.5 MHz

Correction data for P.M :200.5 MHz

13. Set both of signal generator controls as follows:

SG1

Frequency :3600MHz

Output Level :-2 dBm

SG2

Frequency :3601MHz

Output Level :-12 dBm

14. On the U3661, after preset, set controls as follows:

Center Frequency :3600.5MHz

Span :2MHz

Attenuator :0dB

Reference Level :-10dBm

dB/div :10 dB/div

15. On the U3661 press as follows to tune pre-selector peak.

PEAK, MKR, NEXT and AUTO PRESEL

3. PERFORMANCE VERIFICATION

16. On the U3661, set controls as follows:

dB/div	:1dB/div
Reference Level	:-30 dBm

17. On the SG1, turn output level off.

18. On the SG2, adjust the output level for a displayed signal of $-30 \text{ dBm} \pm 0.1 \text{ dB}$ on the U3661 screen.

19. On the SG1, turn output level on.

20. On the SG1, adjust output level until the signal level at 2.5 division in the left hand part on the U3661 screen is lowed by 1dB from -30dBm.

21. Remove the RF cable from the input terminal of U3661, connect RF power sensor there.

22. Set correction data on the RF power meter to 3.6 GHz.

23. Record the level of the RF power meter reading on the performance test data sheets.

24. Repeat steps 14 through 23 for the center frequency 7600.5MHz, as the following setting.

SG1

Frequency	:7600 MHz
-----------	-----------

SG2

Frequency	:7601 MHz
-----------	-----------

U3661 Center Frequency	:7600.5 MHz
------------------------	-------------

Correction data for P.M	:7.6 GHz
-------------------------	----------

[Pre-amplifier ON Condition]

25. On the both of SG, set controls as follows:

SG2

Frequency	:11MHz
-----------	--------

Output Level	:-35 dBm
--------------	----------

SG1

Frequency	:10.5MHz
-----------	----------

Output Level	:-45 dBm
--------------	----------

3. PERFORMANCE VERIFICATION

26. On the U3661, after preset, set controls as follows:

Center Frequency	:10.5MHz
Span	:2MHz
RBW	:100kHz
VBW	:1kHz
Attenuator	:0dB
dB/div	:1dB/div
HIGHSENS	:ON

27. Turn output level off of the SG1.

28. On the SG2, adjust SG2 output level for a displayed signal of -50 dBm \pm 0.1 dB on the U3661 screen.

29. Turn output level on of the SG1.

30. On the SG1, adjust SG1 output level until the signal level at 2.5 division in the left hand part on the U3661 screen is lowered by 1dB from -50 dBm.

31. Repeat steps 9 through 12.

3.2.18. Sweep Time Accuracy

Description

A low frequency signal (Square Wave) is displayed on the U3661 in ZERO span mode, and measure the frequency of the displayed signal using Video trigger.

Specification

$\leq \pm 5\%$ of sweep time setting

Equipment used

Signal Generator	:SG4
RF Cable	:BNC(m)-BNC(m)
Adapter	:N (m)-BNC (f)

Setup

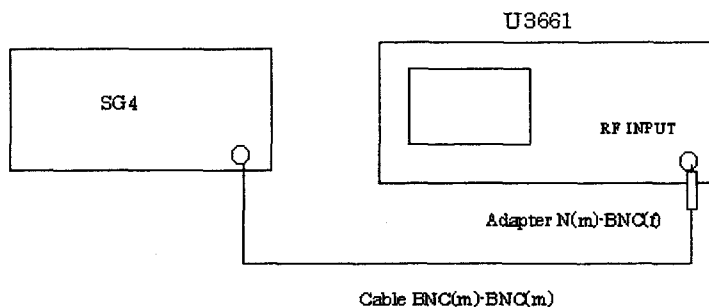

Figure 3-19 Setup of a Sweep Time Accuracy Test

Procedure

1. Connect equipment as shown in Figure 3-19.
2. On the SG4, set controls as follows:

Frequency	:22kHz
Output Level	:-10dBm
Wave form	:Square

3. On the U3661, after preset, set controls as follows:

Center Frequency	:0MHz
Span	:ZERO
Reference Level	:-10dBm
dB/div	:1dB/div
Sweep Time	:50 μ sec

4. On the U3661, press as follows to set trigger mode to VIDEO.

MENU, TRIGGERTRIG, VIDEO and **+**

5. On the U3661, adjust trigger level for sweep using data knob.
6. On the U3661, press as follows for single sweep.

3. PERFORMANCE VERIFICATION

MENU, SWEEP MODE and SINGLE SWEEP

7. On the U3661, after sweep has completed, press **MKR** then move it to leading edge on the waveform.
8. Record the time of the marker reading on the performance verification test record sheets.
9. Repeat steps 6 through 8 for each sweep time setting listed in Table 3-20.

Table 3-20. Setting for Sweep Time Accuracy Test

Sweep Time	Frequency of Signal Generator
50 μ sec	22 kHz
100 μ sec	11 kHz
200 μ sec	5.5 kHz
500 μ sec	2.2 kHz
1 msec	1.1 kHz
2 msec	550 Hz
5 msec	220 Hz
10 msec	110 Hz
20 msec	55 Hz
50 msec	22 Hz
100 msec	11 Hz
200 msec	5.5 Hz
500 msec	2.2 Hz
1 sec	1.1 Hz
2 sec	0.55 Hz
5 sec	0.22 Hz
10 sec	0.11 Hz

3.2.19. Residual Response

Description

This test checks for residual responses under pre amplifier on and off cases.

Any response located above the display line is measured in a narrow frequency span and RBW.

The RF INPUT is terminated in 50 Ω .

Specification

With no signal at input and 0dB input attenuation

< -100 dBm Frequency Range: 1MHz to 3.2 GHz, Pre Amp OFF

< -90 dBm Frequency Range : > 3.2 GHz

< -105 dBm Frequency Range: 1 MHz to 3.2 GHz, Pre Amp ON

Equipment used

Coaxial 50 Ω termination :RNA
 Adapters: :N (m) -SMA (f)

Setup

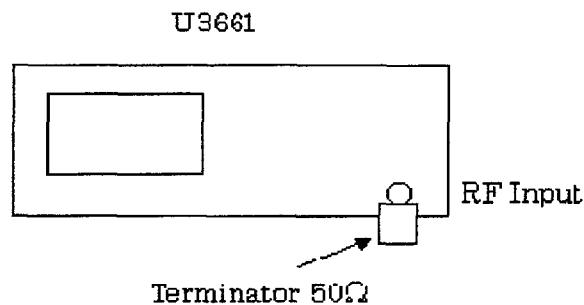

Figure 3-20 Setup of Residual Response Test

Procedure

Under Pre-amplifier Off Condition

[Frequency Range: 1 MHz to 3.2 GHz]

1. On the U3661, press as follows to perform auto calibration.

SHIFT, 7(CAL), Cal All

2. Connect equipment as shown in Figure 3-20.
3. On the U3661, after preset, set controls as follows:

Center Frequency	:1.3MHz
Span	:2MHz
CF Step Size	:1.9MHz
Reference Level	:-50dBm
ATT	:0dB
RBW	:10kHz
VBW	:300 Hz

4. On the U3661, press as follows to put display line at -100 dBm position.

MENU, DSP LINE ON OFF (ON), 1,0,0 and MHz (-dBm)

3. PERFORMANCE VERIFICATION

5. On the U3661, press as follows for single sweep.

MENU, SWEEP MODE and SINGLE SWEEP

The noise level should be at least 3 dB below the display line. If it is not, it will be necessary to reduce the Span and RBW to reduce the noise level. If the span is reduced, reduce the CF Step to no more than 95% of the Span.

6. If a residual is suspected, perform single sweep again.
A residual response will persist, but a noise peak will not. Record the frequency and amplitude of any responses above the display line.
7. If a response is marginal, verify the response amplitude as follows:
 - 1) Place the marker on the peak of the response in the question.
 - 2) On the U3661, press as follows to set marker frequency to center.

MKR→ and MKR → CF

- 3) On the U3661, press as follows to set RBW auto mode.

BW and RBW AUTO/MNL (AUTO)

- 4) Continue to reduce the Span until a RBW of 1 kHz is reached.
- 5) On the U3661, press as follows to set the signal peak to center.

PEAK, MKR → and Peak → CF

- 6) Record the frequency and amplitude of any residual response above the display line.
8. Check for residuals up to center frequency 3.2 GHz using the procedure of step 5 through 7 above.

To change the center frequency, then press the **CENTER** and **Δ** keys.

[Under Pre-Amplifier On Condition]

9. On the U3661, press **LEVEL** and **Hi Sens ON** to set pre-amplifier to on.
10. On the U3661, press to put display line at -105dBm position.

MENU, DSP LINE ON OFF (ON), 1,0,5 and MHz (-dBm)

11. Repeat steps 5. Through 10.

3. PERFORMANCE VERIFICATION

[Under Pre-Amplifier OFF Condition]

[Residual response in the band 3.2 GHz to 7.1 GHz]

12. On the U3661, set controls as follows;

Center Frequency	:3.325GHz
Span	:50MHz
CF Step	:47.5MHz
RBW	:100kHz
VBW	:300 Hz

13. On the U3661, press as follows to put display line at -90 dBm position.

MENU, DSP LINE ON/OFF (ON), 9, 0 and MHz (-dBm)

14. Repeat steps 7 through 10 until the center frequency of 7.425 GHz.

3. PERFORMANCE VERIFICATION

3.3 Tracking Generator Performance Verification Procedure (Optional)

When the U3661 with tracking generator as option, perform this verification.

3.3.1. Absolute Output Level Accuracy

Description

A calibrated power sensor is connected to the tracking generator output to measure the power level at 30 MHz and output level -10 dBm.

Specification

$\leq -10\text{dBm} \pm 0.5\text{dB}$ at Center 30MHz, output level -10dBm.

Equipment used

RF Power meter	:P.M
RF Power sensor	:P.S

Setup

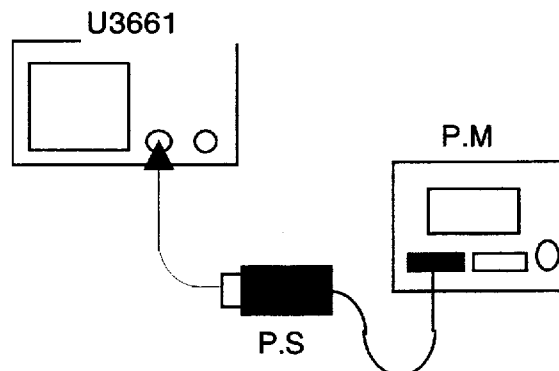

Figure 3-21 Setup of Absolute Output Level Accuracy Test

Procedure

1. On the PM, perform zeroing and calibration.
2. Connect the equipment as shown Figure3-21

3. PERFORMANCE VERIFICATION

3. On the U3661, after preset, set controls as follows:

Center Frequency	:30MHz
Span	:ZERO
TG Output Level	:-10dBm
TG	:ON

4. On the PM, set correction data to 30 MHz.
5. Record the measurement value of the P.M on the performance verification test record sheets.

3.3.2. Output Level Flatness

Description

Output level flatness is measured by RF power meter in relative mode, referenced to center frequency at 30 MHz and output level -10 dBm.

TG is stepped to several frequencies throughout its range.

Specification

$\leq \pm 0.7$ dB Frequency Range: 100 kHz to 1 GHz

$\leq \pm 1.5$ dB Frequency Range: 100 kHz to 2.2 GHz

Equipment used

Power meter	:P.M
Power sensor	:P.S

3. PERFORMANCE VERIFICATION

Setup

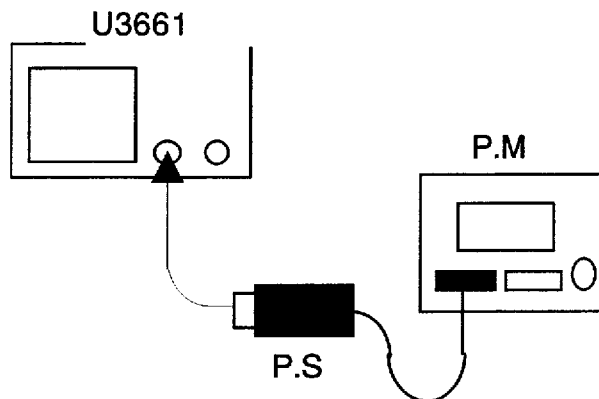

Figure 3-22 Setup of Output Level Flatness Test.

Procedure

1. On the P.M, perform ZERO and calibration.
2. Connect equipment as shown in Figure 3-22.
3. On the U3661, set controls as follows:

Center Frequency	:30MHz
Span	:ZERO
TG level	:-10dBm
TG	:ON

4. On the PM, set the correction data for 30 MHz.
5. On the PM, set relative measurement mode.
6. On the U3661, set center frequency to 100 kHz.
7. On the P.M, set correction data for 100 kHz.
8. Record P.M reading on the performance verification test record sheets.
9. Repeat steps 6 through 8 for each center frequency listed in Table 3-21.

Table 3-21 Setting for Output Flatness Test

Center Frequency(Hz) and Correction Data
30 M
100 k
300 k
1 M
3 M
10 M
100 M
200 M
400 M
600 M
800 M
1 G
1.2 G
1.4 G
1.6 G
1.8 G
2.0 G
2.2 G

3.3.3. Output Level Switching Accuracy

Description

Measure switching accuracy of TG output attenuator, after CAL ALL performed.
 Measure level of several frequencies against output level -10.0 dBm as reference.
 The measurement of deviation from -10 dBm point using normalized function.
 When change TG output level, reference level setting also change for trace data
 to stay center of vertical on the screen.

Specification

- ≤ ± 1.0 dB Frequency Range: 100 kHz to 1 GHz)
- ≤ ± 2.0 dB Frequency Range: 100 kHz to 2.2 GHz

Equipment used

Adapter :N(m)-SMA(f)
 RF Cable :SNA(f)-SMA(f)

3. PERFORMANCE VERIFICATION

Setup

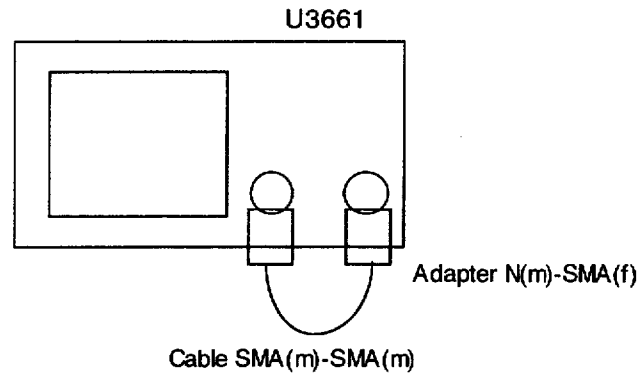

Figure 3-23 Setup of Output Switching Accuracy Test

Procedure

1. On the U3661, after preset, press as follows to perform auto calibration.

SHIFT, 7(CAL) and CAL ALL

2. Connect equipment as shown in Figure 3-23
3. On the U3661, after calibration done, set controls as follows:

Center Frequency	:30MHz
Span	:50kHz
Reference level	:-5dB
dB/div	:1dB/div
RBW	:1MHz
VBW	:10kHz
TG level	:-10 dBm

4. On the U3661, press as follows to set normalized mode to on.

TRACE, TRACE MATH, NORMALIZE and INSTANT NORMALIZE

5. On the U3661, set TG output level to 0 dBm and reference level to 5 dBm.
6. On the U3661, press **MARKER** to activate marker.
7. On the U3661, press as follows for single sweep.

MENU, SWEEP MODE and SINGLE SWEEP

3. PERFORMANCE VERIFICATION

8. Record the level of marker on the performance verification test record sheets.
9. Repeat 4 through 7 each TG output level and reference level listed in Table 3-22

Table 3- 22 Setting for TG output Level Switching Accuracy Test

TG Output Level	Reference Level
-14.9 dBm	-9.9 dBm
-15.0 dBm	-10.0 dBm
-19.9 dBm	-14.9 dBm
-20.0 dBm	-15.0 dBm
-30.0 dBm	-25.0 dBm

10. Repeat steps 2 through 8 for each frequency listed in Table 3-23

Table 3-23 Setting for TG Output Switching Accuracy Test

Center Frequency(Hz)
100 k
1 M
10 M
100 M
200 M
400 M
600 M
800 M
1 G
1.5 G
2 G
2.2 G

3.3.4. Harmonic Distortion

Description

The measurement for tracking generator harmonic spurious outputs.

The tracking generator output is connected to the input of a spectrum analyzer, and then set to several different frequencies as the amplitude of the second harmonics relative to the fundamental is measured at each frequency.

Specification

>20 dBc

3. PERFORMANCE VERIFICATION

Equipment used

Spectrum analyzer	:SPA
Adapter	:N(m)-SMA(f)
RF Cable	:SNA (m)-SMA (m)

Setup

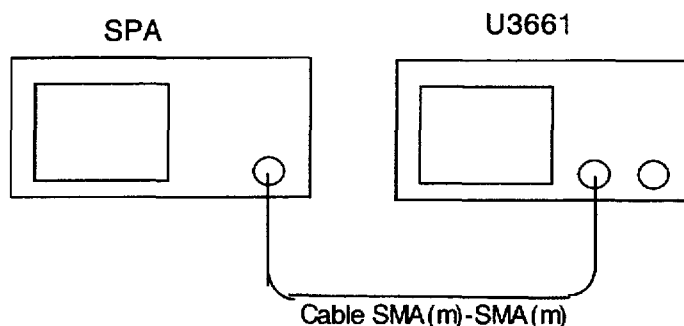

Figure 3-24 Setup of Harmonic Distortion Test

Procedure

1. Connect equipment as shown in Figure 3-24.
2. On the U3661, after preset, set controls as follows:

Center Frequency	:100kHz
Span	:ZERO
RBW	:1kHz
TG	:ON
TG level	:-10 dBm

3. On the SPA, after preset, set controls as follows:

Center Frequency	:350kHz
Span	:600kHz
Reference level	:0 dBm

4. On the SPA, press **SINGLE** for single sweep.
5. Measure the level difference of signal between fundamental and second harmonic signal.
6. Record measured level difference on the performance verification test record sheets.
7. Repeat steps 2 through 6 for each setting listed in Table 3-24.
8. Record maximum data on the performance verification test record sheets as result.

Table 3-24 Setting for harmonic Distortion Test

U3661	SPA Setting	
Center Frequency	Center Frequency	Span
200kHz	350kHz	600kHz
500kHz	750kHz	600kHz
1MHz	3.5MHz	6MHz
2MHz	3.5MHz	6MHz
5MHz	7.5MHz	6MHz
10MHz	35MHz	60MHz
20MHz	35MHz	60MHz
50MHz	75MHz	60MHz
100MHz	350MHz	600MHz
200MHz	350MHz	600MHz
500MHz	750MHz	600MHz
1GHz	3.5GHz	6GHz
1.5GHz	3.5GHz	6GHz
2GHz	3.5GHz	6GHz
2.2GHz	3.5GHz	6GHz

3.3.5. Non-harmonic Distortion.

Description

Measure the level difference between fundamental and signal except for second harmonic using SPA.

Specification

> 30 dBc

Equipment used

- Spectrum analyzer :SPA
- Adapter :N(m)-SMA(f)
- RF Cable :SNA (m)-SMA (m)

3. PERFORMANCE VERIFICATION

Setup

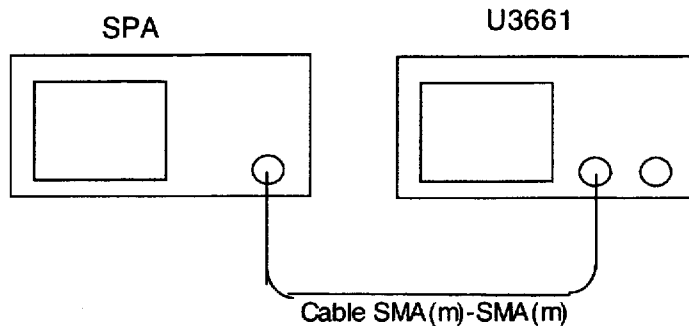

Figure 3-25 Setup of Non-Harmonic Distortion Test

Procedure

1. Connect equipment as shown in Figure 3-25.
2. On the U3661, after preset, set controls as follows:

Center Frequency	:0Hz
Span	:ZERO
Center Frequency step	:10MHz
TG	:ON
TG level	:-10 dBm

3. On the SPA, after preset, set controls as follows;

Frequency	:6 GHz
-----------	--------

4. On the U3661, press Δ key, to set center frequency by 10 MHz step up to 2.2 GHz.
5. Capture the biggest harmonic signal except second harmonic signal.
6. Record the level difference between fundamental and biggest harmonic signal.

3.3.6. TG Leakage

Description

Measure the leakage of TG signal by measuring U3661 noise level.

TG output and RF input are terminated in 50 Ω .

Specification

\leq -95 dBm (Input attenuator 0 dB)

Equipment used

50Ω Terminator :NRA x 2pcs

Setup

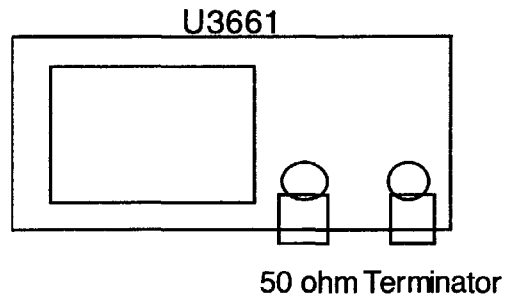

Figure 3-26 Setup of TG Leakage Test

Procedure

1. Connect equipment as shown in Figure 3-26.
2. On the U3661, after preset, set controls as follows:

Start Frequency	:30MHz
Stop Frequency	:2.2GHz
Sweep Time	:20sec
RBW	:1kHz
VBW	:10Hz
Reference Level	:-60dBm
Input Attenuator	:0dB
TG Output Level	:0 dBm
TG	:ON

(Ignore UNCAL message under above setting condition)

3. On the U3661, press as follows for single sweep.

MENU, SWEEP MODE and SINGLE SWEEP

4. On the U3661, after single sweep has completed, press **PEAK** to capture the peak signal.
5. Record the measurement data on the performance verification test record sheets.

3. PERFORMANCE VERIFICATION

3.4. Performance Verification Test Record Sheet

Performance Verification Test Record

Report Number :

Customer Name :

Address :

Description :

Model Number :

Serial Number :

Asset Number :

Testing Environment : ± °C / % ± % RH

Verification Date:

Due Date:

Equipment Used:

Model No.	Description	Trace No.	Cal Due Date
-----------	-------------	-----------	--------------

Test Officer

Date:

Head of Laboratory

Date:

Performance Verification Test Record

Model :
Serial Number:

Date: _____

1. 10 MHz Reference Output Accuracy

Test Data	Specification			Result
	Min.(Hz)	Measured Value(Hz)	Max(Hz)	Pass/Fail
3 GHz	2 999 994 000		3 000 006 000	

2. Calibration Signal Output Amplitude Accuracy

Test Data	Specification			Result
	Min(dBm)	Measured Value(dBm)	Max(dBm)	Pass/Fail
Reference	-		-	-
Cal signal	-		-	-
Calculate	-0.3		+0.3	

3. Displayed Average Noise Level

Test Data		Specification			Result
Pre-amplifier	Center Frequency (Hz)	Min.(dBm)	Measured Value(dBm)	Max.(dBm)	Pass/Fail
ON	1 M	N/A		-116.99	
	10.1 M	N/A		-116.98	
	101 M	N/A		-116.80	
	501 M	N/A		-115.99	
	1001M	N/A		-114.99	
	1.5 G	N/A		-114.0	
	2.0 G	N/A		-113.0	
	2.5 G	N/A		-112.0	
	3.0 G	N/A		-111.0	
	3.01 G to 7.1 G	N/A		-105	
OFF	6.7 G to 14.5 G	N/A		-110	
	13.7 G to 26.5 G	N/A		-105	
	1 M	N/A		-131.97	
	10.1 M	N/A		-131.97	
	101 M	N/A		-131.70	
	501 M	N/A		-130.50	
	1001M	N/A		-128.99	
	1.5 G	N/A		-127.5	
	2.0 G	N/A		-126	
	2.5 G	N/A		-106.5	
3.0 G	N/A		-123		

4. Resolution Bandth width Switching Accuracy

Test Data	Specification			Result
RBW (Hz)	Min.(dB)	Measured Value(dB)	Max.(dB)	Pass/Fail
3 M	-	Ref.(0)	-	
1 M	-1.0		+1.0	
300 k	-1.0		+1.0	
100 k	-1.0		+1.0	
30 k	-1.0		+1.0	
10 k	-1.0		+1.0	
3 k	-1.0		+1.0	
1 k	-1.0		+1.0	
300 (Option)	-1.0		+1.0	
100 (Option)	-1.0		+1.0	

Performance Verification Test Record

5. Resolution Bandwidth Accuracy and Selectivity

5.1. Resolution Bandwidth

Test Data RBW (Hz)	Specification			Result Pass/Fail
	Min.(Hz)	Measured Value(Hz)	Max.(Hz)	
3 M	2.25 M		3.75 M	
1 M	0.8 M		1.2 M	
300 k	240 k		360 k	
100 k	80 k		120 k	
30 k	24 k		36 k	
10 k	8 k		12 k	
3 k	2.4 k		3.6 k	
1 k	0.8 k		1.2 k	
300(Option)	240		360	
100(Option)	80		120	

5.2. Resolution Bandwidth Selectivity

Test Data RBW (Hz)	Measured Value(Hz)		Specification			Result Pass/Fail
	60dB	3dB	Min.	Selectivity	Max.	
3M			N/A		15	
1M			N/A		15	
300k			N/A		15	
100k			N/A		15	
30k			N/A		15	
10k			N/A		15	
3k			N/A		15	
1k			N/A		15	
300(Option)			N/A		15	
100(Option)			N/A		15	
30(Option)			N/A		15	

6. IF Gain Uncertainty

6.1. RBW = 1 MHz

Setting RBW(Hz)	Test Data	Specification			Result Pass/Fail
	Reference Level(dBm)	Min(dB)	Measured Value(dB)	Max.(dB)	
1 M	-1.0	-0.5		+0.5	
	-2.0	-0.5		+0.5	
	-3.0	-0.5		+0.5	
	-4.0	-0.5		+0.5	
	-5.0	-0.5		+0.5	
	-6.0	-0.5		+0.5	
	-7.0	-0.5		+0.5	
	-8.0	-0.5		+0.5	
	-9.0	-0.5		+0.5	
	-10.0	-0.5		+0.5	
	-20.0	-0.5		+0.5	
	-30.0	-0.5		+0.5	
	-40.0	-0.5		+0.5	
-50.0	-0.5		+0.5		

6.2. RBW = 3 kHz

Setting RBW(Hz)	Test Data	Specification			Result Pass/Fail
	Reference Level(dBm)	Min(dB)	Measured Value(dB)	Max.(dB)	
3 k	-1.0	-0.5		+0.5	
	-2.0	-0.5		+0.5	
	-3.0	-0.5		+0.5	
	-4.0	-0.5		+0.5	
	-5.0	-0.5		+0.5	
	-6.0	-0.5		+0.5	
	-7.0	-0.5		+0.5	
	-8.0	-0.5		+0.5	
	-9.0	-0.5		+0.5	
	-10.0	-0.5		+0.5	
	-20.0	-0.5		+0.5	
	-30.0	-0.5		+0.5	
	-40.0	-0.5		+0.5	
-50.0	-0.5		+0.5		

Performance Verification Test Record

6.3. RBW = 100 Hz(Option)

Setting	Test Data		Specification		Result
	Reference Level(dBm)	Min(dB)	Measured Value(dB)	Max.(dB)	Pass/Fail
100	-1.0	-0.5		+0.5	
	-2.0	-0.5		+0.5	
	-3.0	-0.5		+0.5	
	-4.0	-0.5		+0.5	
	-5.0	-0.5		+0.5	
	-6.0	-0.5		+0.5	
	-7.0	-0.5		+0.5	
	-8.0	-0.5		+0.5	
	-9.0	-0.5		+0.5	
	-10.0	-0.5		+0.5	
	-20.0	-0.5		+0.5	
	-30.0	-0.5		+0.5	
-40.0	-0.5		+0.5		
-50.0	-0.5		+0.5		

7. Input Attenuator Switching Accuracy

7.1 Center Frequency = 4 GHz

Attenuator (dB)	Reference Level(dBm)	Specification			Result
		Min(dB)	Measured Value(dB)	Max(dB)	Pass/Fail
10	0	-	0(Ref)	-	
20	-10	-1.1		+1.1	
30	-20	-1.1		+1.1	
40	-30	-1.1		+1.1	
50	-40	-1.1		+1.1	

7.2. Center Frequency = 15 GHz

Attenuator (dB)	Reference Level(dBm)	Specification			Result
		Min(dB)	Measured Value(dB)	Max(dB)	Pass/Fail
10	0	-	0(Ref)	-	
20	-10	-1.3		+1.3	
30	-20	-1.3		+1.3	
40	-30	-1.3		+1.3	
50	-40	-1.3		+1.3	

7.3. Center Frequency = 18 GHz

Attenuator (dB)	Reference Level(dBm)	Specification			Result
		Min(dB)	Measured Value(dB)	Max(dB)	Pass/Fail
10	0	-	0(Ref)	-	
20	-10	-1.3		+1.3	
30	-20	-1.3		+1.3	
40	-30	-1.3		+1.3	
50	-40	-1.3		+1.3	

8. Scale Fidelity

8.1. 1 dB/div

Input Signal Level (dBm, Nominal)	dB from Reference level (dB)	Measured Value(dB)	Specification			Result
			Min.(dB)	Incremental Error(dB)	Max.(dB)	Pass/Fail
0	0	Reference	Reference	Reference	Reference	
-1	-1		-0.2		+0.2	
-2	-2		-0.2		+0.2	
-3	-3		-0.2		+0.2	
-4	-4		-0.2		+0.2	
-5	-5		-0.2		+0.2	
-6	-6		-0.2		+0.2	
-7	-7		-0.2		+0.2	
-8	-8		-0.2		+0.2	
-9	-9		-0.2		+0.2	
-10	-10		-0.2		+0.2	

Performance Verification Test Record

8.2. 10 dB/div

Input Signal Level (dBm, Nominal)	dB from Reference level (dB)	Measured Value (dB)	Specification			Result
			Min.(dB)	Incremental Error(dB)	Max.(dB)	
0	0	Reference	Reference	Reference	Reference	Pass/Fail
-10	-10		-1.0		+1.0	
-20	-20		-1.0		+1.0	
-30	-30		-1.0		+1.0	
-40	-40		-1.0		+1.0	
-50	-50		-1.0		+1.0	
-60	-60		-1.0		+1.0	
-70	-70		-1.0		+1.0	
-80	-80		-1.0		+1.0	
-90	-90		-1.0		+1.0	

8.3. Linear

Signal Level(Nominal)		div. from Reference Level	Specification			Result
(dBm)	(mV)		Min(mV)	Measured Value(mV)	Max(mV)	
0	223.6	0	-	Reference	-	Pass/Fail
-0.92	201.24	1	190.06		212.42	
-1.94	178.88	2	167.70		190.06	
-3.10	156.52	3	145.34		167.70	
-4.44	134.16	4	122.98		145.34	
-6.02	111.8	5	100.62		122.98	
-7.96	89.44	6	78.26		100.62	
-10.46	67.08	7	55.90		78.26	
-13.98	44.72	8	33.54		55.90	
-20.00	22.36	9	11.18		33.54	

9. Residual FM

Measured Value			
Marker Reading	3dB Slope	FM Deviation	
Δf	Δ level		

Specification			Result
Min(Hz)	Residual FM(Hz-p)	Max(Hz)	Pass/Fail
N/A		60	

10. Noise Sideband

Test Data		Specification			Result
Center Frequency(Hz)	Offset Frequency(Hz)	Min (dBc/Hz)	Measured Value(dBc/Hz)	Max (dBc/Hz)	Pass/Fail
1.0 G	10 k	N/A		-105	
	20 k			-100	

11. Image, Multiple, and Out of Band Response

Test Data		Specification			Result
Center Frequency of U3661	Frequency of SG2	Min (dBc)	Measured Value(dBc)	Max(dBc)	Pass/Fail
1.0 GHz	1.442800 GHz	N/A		-50	
	1.110700 GHz	N/A		-50	
	9.122800 GHz	N/A		-50	
	7.092100 GHz	N/A		-50	
	19.245600 GHz	N/A		-50	
5.5 GHz	5.942800 GHz	N/A		-50	
	11.221400 GHz	N/A		-50	
	16.942800 GHz	N/A		-50	
	22.664200 GHz	N/A		-50	
11.0 GHz	11.442800 GHz	N/A		-50	
	5.389300 GHz	N/A		-50	
	16.610700 GHz	N/A		-50	
	22.221400 GHz	N/A		-50	
24.0 GHz	24.442800 GHz	N/A		-50	
	5.833950 GHz	N/A		-50	
	11.889300 GHz	N/A		-50	
	17.944650 GHz	N/A		-50	

Performance Verification Test Record

12. Frequency Readout & Frequency Counter Marker Accuracy

12.1. Frequency Readout Accuracy

Test Data Center Frequency(GHz)	Specification			Result
	Min(Hz)	Measured Value(Hz)	Max(Hz)	Pass/Fail
2 GHz	1.999948 G		2.000052 G	
	1.99948 G		2.00052 G	
	1.99895 G		2.00105 G	
	1.99745 G		2.00255 G	
	1.9948 G		2.0052 G	
	1.8995 G		2.1005 G	
5 GHz	4.999948 G		5.000052 G	
	4.99948 G		5.00052 G	
	4.99895 G		5.00105 G	
	4.99745 G		5.00255 G	
	4.9948 G		5.0052 G	
	4.8995 G		5.1005 G	
11 GHz	10.999948 G		11.000052 G	
	10.99948 G		11.00052 G	
	10.99895 G		11.00105 G	
	10.99745 G		11.00255 G	
	10.9948 G		11.0052 G	
	10.8995 G		11.1005 G	
18 GHz	17.999948 G		18.000052 G	
	17.99948 G		18.00052 G	
	17.99895 G		18.00105 G	
	17.99745 G		18.00255 G	
	17.9948 G		18.0052 G	
	17.8995 G		18.1005 G	

12.2. Frequency Counter Accuracy

Test Data Center Frequency(GHz)	Specification			Result
	Min.(GHz)	Measured Value(GHz)	Max.(GHz)	Pass/Fail
2	1.999997994		2.000002006	
5	4.999994994		5.000005006	
11	10.999988989		11.000011011	
18	17.999981979		18.000018021	

13. Second Harmonic Distortion Test

Test Data		Specification			Result
Fundamental Frequency (GHz)	Second Harmonic Frequency (GHz)	Min. (dBc)	Measured Value (dBc)	Max. (dBc)	Pass/Fail
1.5	3.0	N/A		-70	
1.9	3.8	N/A		-80	

14. Frequency Response

14.1. Pre-amplifier Off

Frequency Range	Test Data(MHz)	Specification			Result
		Min. (dB)	Measured Value(dB)	Max. (dB)	Pass/Fail
9 kHz to 3.2GHz	100.0	- 1.0		+1.0	
	200.0	- 1.0		+1.0	
	300.0	- 1.0		+1.0	
	400.0	- 1.0		+1.0	
	500.0	- 1.0		+1.0	
	600.0	- 1.0		+1.0	
	700.0	- 1.0		+1.0	
	800.0	- 1.0		+1.0	
	900.0	- 1.0		+1.0	
	1000.0	- 1.0		+1.0	
	1100.0	- 1.0		+1.0	
	1200.0	- 1.0		+1.0	
	1300.0	- 1.0		+1.0	
	1400.0	- 1.0		+1.0	
	1500.0	- 1.0		+1.0	
	1600.0	- 1.0		+1.0	
	1700.0	- 1.0		+1.0	
Cont'd	1800.0	- 1.0		+1.0	

Performance Verification Test Record

9 kHz to 3.2GHz	1900.0	- 1.0		+1.0	
	2000.0	- 1.0		+1.0	
	2100.0	- 1.0		+1.0	
	2200.0	- 1.0		+1.0	
	2300.0	- 1.0		+1.0	
	2400.0	- 1.0		+1.0	
	2500.0	- 1.0		+1.0	
	2600.0	- 1.0		+1.0	
	2700.0	- 1.0		+1.0	
	2800.0	- 2.0		+2.0	
	2900.0	- 2.0		+2.0	
	3000.0	- 2.0		+2.0	
	3100.0	- 2.0		+2.0	
3200.0	- 2.0		+2.0		

Frequency Range	Test Data(MHz)	Specification			Result
		Min.(dB)	Measured Value(dB)	Max.(dB)	Pass/Fail
3.0 GHz to 7.1 GHz	3100.0	-1.5		+1.5	
	3200.0	-1.5		+1.5	
	3300.0	-1.5		+1.5	
	3400.0	-1.5		+1.5	
	3500.0	-1.5		+1.5	
	3600.0	-1.5		+1.5	
	3700.0	-1.5		+1.5	
	3800.0	-1.5		+1.5	
	3900.0	-1.5		+1.5	
	4000.0	-1.5		+1.5	
	4100.0	-1.5		+1.5	
	4200.0	-1.5		+1.5	
	4300.0	-1.5		+1.5	
	4400.0	-1.5		+1.5	
	4500.0	-1.5		+1.5	
	4600.0	-1.5		+1.5	
	4700.0	-1.5		+1.5	
	4800.0	-1.5		+1.5	
	4900.0	-1.5		+1.5	
	5000.0	-1.5		+1.5	
	5100.0	-1.5		+1.5	
	5200.0	-1.5		+1.5	
	5300.0	-1.5		+1.5	
	5400.0	-1.5		+1.5	
	5500.0	-1.5		+1.5	
	5600.0	-1.5		+1.5	
	5700.0	-1.5		+1.5	
	5800.0	-1.5		+1.5	
5900.0	-1.5		+1.5		
6000.0	-1.5		+1.5		
6100.0	-1.5		+1.5		
6200.0	-1.5		+1.5		
6300.0	-1.5		+1.5		
6400.0	-1.5		+1.5		
6500.0	-1.5		+1.5		
6600.0	-1.5		+1.5		
6700.0	-1.5		+1.5		
6800.0	-1.5		+1.5		
6900.0	-1.5		+1.5		
7000.0	-1.5		+1.5		
7100.0	-1.5		+1.5		

Frequency Range	Test Data(MHz)	Specification			Result
		Min.(dB)	Measured Value(dB)	Max.(dB)	Pass/Fail
6.7 GHz to 14.5 GHz	6800.0	-3.5		+3.5	
	7000.0	-3.5		+3.5	
	7200.0	-3.5		+3.5	
	7400.0	-3.5		+3.5	
	7600.0	-3.5		+3.5	
Cont'd	7800.0	-3.5		+3.5	

Performance Verification Test Record

6.7 GHz to 14.5 GHz	8000.0	-3.5		+3.5	
	8200.0	-3.5		+3.5	
	8400.0	-3.5		+3.5	
	8600.0	-3.5		+3.5	
	8800.0	-3.5		+3.5	
	9000.0	-3.5		+3.5	
	9200.0	-3.5		+3.5	
	9400.0	-3.5		+3.5	
	9600.0	-3.5		+3.5	
	9800.0	-3.5		+3.5	
	10000.0	-3.5		+3.5	
	10200.0	-3.5		+3.5	
	10400.0	-3.5		+3.5	
	10600.0	-3.5		+3.5	
	10800.0	-3.5		+3.5	
	11000.0	-3.5		+3.5	
	11200.0	-3.5		+3.5	
	11400.0	-3.5		+3.5	
	11600.0	-3.5		+3.5	
	11800.0	-3.5		+3.5	
	12000.0	-3.5		+3.5	
	12200.0	-3.5		+3.5	
	12400.0	-3.5		+3.5	
	12600.0	-3.5		+3.5	
	12800.0	-3.5		+3.5	
	13000.0	-3.5		+3.5	
	13200.0	-3.5		+3.5	
	13400.0	-3.5		+3.5	
13600.0	-3.5		+3.5		
13800.0	-3.5		+3.5		
14000.0	-3.5		+3.5		
14200.0	-3.5		+3.5		
14400.0	-3.5		+3.5		

Frequency Range	Test Data(MHz)	Specification			Result
		Min.(dB)	Measured Value(dB)	Max.(dB)	Pass/Fail
13.7 GHz to 26.5 GHz	13800.0	-4.0		+4.0	
	14000.0	-4.0		+4.0	
	14200.0	-4.0		+4.0	
	14400.0	-4.0		+4.0	
	14600.0	-4.0		+4.0	
	14800.0	-4.0		+4.0	
	15000.0	-4.0		+4.0	
	15200.0	-4.0		+4.0	
	15400.0	-4.0		+4.0	
	15600.0	-4.0		+4.0	
	15800.0	-4.0		+4.0	
	16000.0	-4.0		+4.0	
	16200.0	-4.0		+4.0	
	16400.0	-4.0		+4.0	
	16600.0	-4.0		+4.0	
	16800.0	-4.0		+4.0	
	17000.0	-4.0		+4.0	
	17200.0	-4.0		+4.0	
	17400.0	-4.0		+4.0	
	17600.0	-4.0		+4.0	
	17800.0	-4.0		+4.0	
	18000.0	-4.0		+4.0	
	18200.0	-4.0		+4.0	
	18400.0	-4.0		+4.0	
	18600.0	-4.0		+4.0	
	18800.0	-4.0		+4.0	
	19000.0	-4.0		+4.0	
	19200.0	-4.0		+4.0	
19400.0	-4.0		+4.0		
19600.0	-4.0		+4.0		
19800.0	-4.0		+4.0		
20000.0	-4.0		+4.0		

Cont'd

Performance Verification Test Record

13.7 GHz to 26.5 GHz	20200.0	-4.0		+4.0	
	20400.0	-4.0		+4.0	
	20600.0	-4.0		+4.0	
	20800.0	-4.0		+4.0	
	21000.0	-4.0		+4.0	
	21200.0	-4.0		+4.0	
	21400.0	-4.0		+4.0	
	21600.0	-4.0		+4.0	
	21800.0	-4.0		+4.0	
	22000.0	-4.0		+4.0	
	22200.0	-4.0		+4.0	
	22400.0	-4.0		+4.0	
	22600.0	-4.0		+4.0	
	22800.0	-4.0		+4.0	
	23000.0	-4.0		+4.0	
	23200.0	-4.0		+4.0	
	23400.0	-4.0		+4.0	
	23600.0	-4.0		+4.0	
	23800.0	-4.0		+4.0	
	24000.0	-4.0		+4.0	
	24200.0	-4.0		+4.0	
	24400.0	-4.0		+4.0	
	24600.0	-4.0		+4.0	
	24800.0	-4.0		+4.0	
	25000.0	-4.0		+4.0	
	25200.0	-4.0		+4.0	
	25400.0	-4.0		+4.0	
	25600.0	-4.0		+4.0	
	25800.0	-4.0		+4.0	
	26000.0	-4.0		+4.0	
26200.0	-4.0		+4.0		
26400.0	-4.0		+4.0		

14.2. Pre-amplifier ON

Frequency Range	Test Data(MHz)	Specification			Result
		Min.(dB)	Measured Value(dB)	Max.(dB)	Pass/Fail
9 kHz to 3.2 GHz	100.0	-1.0		+1.0	
	200.0	-1.0		+1.0	
	300.0	-1.0		+1.0	
	400.0	-1.0		+1.0	
	500.0	-1.0		+1.0	
	600.0	-1.0		+1.0	
	700.0	-1.0		+1.0	
	800.0	-1.0		+1.0	
	900.0	-1.0		+1.0	
	1000.0	-1.0		+1.0	
	1100.0	-1.0		+1.0	
	1200.0	-1.0		+1.0	
	1300.0	-1.0		+1.0	
	1400.0	-1.0		+1.0	
	1500.0	-1.0		+1.0	
	1600.0	-1.0		+1.0	
	1700.0	-1.0		+1.0	
	1800.0	-1.0		+1.0	
	1900.0	-1.0		+1.0	
	2000.0	-1.0		+1.0	
	2100.0	-1.0		+1.0	
	2200.0	-1.0		+1.0	
	2300.0	-1.0		+1.0	
	2400.0	-1.0		+1.0	
	2500.0	-1.0		+1.0	
	2600.0	-1.0		+1.0	
	2700.0	-2.0		+2.0	
	2800.0	-2.0		+2.0	
	2900.0	-2.0		+2.0	
	3000.0	-2.0		+2.0	
	3100.0	-2.0		+2.0	
	3200.0	-2.0		+2.0	

Performance Verification Test Record

15. Span Accuracy

Setting		Test Data(Hz)	Specification			Result
Center Frequency (GHz)	Span(Hz)		Min(Hz)	Measured Value(Hz)	Max(Hz)	Pass/Fail
2	50 k	40 k	38.8 k		41.2 k	
	400 k	400 k	388 k		412 k	
	2 M	1.6 M	1.552 M		1.648 M	
	2.01 M	1.608 M	1.55976 M		1.65624 M	
	5 M	4 M	3.88 M		4.12 M	
	10 M	8 M	7.76 M		8.24 M	
	20 M	16 M	15.52 M		16.48 M	
	50 M	40 M	38.8 M		41.2 M	
	100 M	80 M	77.6 M		82.4 M	
	200 M	160 M	155.2 M		164.8 M	
	500 M	400 M	388 M		412 M	
	1 G	0.8 G	0.776 G		0.824 G	
	2 G	1.6 G	1.552 G		1.648 G	
4.5	4 G	3.2 G	3.104 G		3.296 G	
	8 G	6.4 G	6.208 G		6.592 G	
10	10 M	8 M	7.76 M		8.24 M	
	100 M	80 M	77.6 M		82.4 M	
	1 G	0.8 G	0.776 G		0.824 G	
	2 G	1.6 G	1.552 G		1.648 G	
17	10 M	8 M	7.76 M		8.24 M	
	100 M	80 M	77.6 M		82.4 M	
	1 G	0.8 G	0.776 G		0.824 G	
	2 G	1.6 G	1.552 G		1.648 G	
10	5 G	4 G	3.88 G		4.12 G	
	10 G	8 G	7.76 G		8.24 G	
	19 G	16 G	15.52 G		16.48 G	

16. Third Order Intermodulation test

Test Data		Specification			Result
Center Frequency(MHz)	VBW	Min.(dB)	Measured Value(dB)	Max.(dBc)	Pass/Fail
105 MHz	300 Hz	N/A		-70	
1500 MHz	300 Hz	N/A		-70	
2000 MHz	100 Hz	N/A		-70	
3600 MHz	100 Hz	N/A		-70	
8000 MHz	100 Hz	N/A		-70	

17. Gain Compression

Setting		Specification			Result
Pre-amplifier	Center Frequency(MHz)	Min.(dBm)	Measured Value(dBm)	Max.(dBm)	Pass/Fail
OFF	10.5	N/A		-10	
	200.5	N/A		-10	
	3600.5	N/A		-10	
	7600.5	N/A		-10	
	3600.5	N/A		-10	
ON	10.5	N/A		-30	
	201.5	N/A		-30	

Performance Verification Test Record

18. Sweep Time Accuracy

Sweep Time Setting(sec)	Test Data(sec)	Specification			Result
		Min(sec)	Measured Value(sec)	Max(sec)	Pass/Fail
50 μ	45 μ	42.75 μ		47.25 μ	
100 μ	90 μ	85.5 μ		94.5 μ	
200 μ	180 μ	171 μ		189 μ	
500 μ	450 μ	427.5 μ		472.5 μ	
1 m	0.9 m	0.855 m		0.945 m	
2 m	1.8 m	1.71 m		1.89 m	
5 m	4.5 m	4.275 m		4.725 m	
10 m	9 m	8.55 m		9.45 m	
20 m	18 m	17.1 m		18.9 m	
50 m	45 m	42.75 m		47.25 m	
100 m	90 m	85.5 m		94.5 m	
200 m	180 m	171 m		189 m	
500 m	450 m	427.5 m		472.5 m	
1	0.9	0.855		0.945	
2	1.8	1.71		1.89	
5	4.5	4.275		4.725	
10	9	8.55		9.45	
20	18	17.1		18.9	

19. Residual response

Test Data		Specification				Result
Pre-Amplifier	Frequency Range	Min.(dBm)	Measured Value		Max.(dBm)	Pass/Fail
			Level(dBm)	Frequency(Hz)		
OFF	1 MHz to 3 GHz	N/A			-100	
ON	1 MHz to 3 GHz	N/A			-105	
OFF	3.2 GHz to 7.1GHz	N/A			-90	

Tracking Generator(Optional)

20. Absolute Output Level Accuracy

Test Data		Specification			Result
Frequency	Output Level	Min(dBm)	Measured Value(dBm)	Max(dBm)	Pass/Fail
30 MHz	-10 dBm	-10.5		-9.5	

21. Output Flatness

Center Frequency(Hz)	Specification			Result
	Min.(dB)	Measured Value(dB)	Max(dB)	Pass/Fail
30 M	-	Ref.(0)	-	
100 k	-0.7		+0.7	
300 k	-0.7		+0.7	
1 M	-0.7		+0.7	
3 M	-0.7		+0.7	
10 M	-0.7		+0.7	
100 M	-0.7		+0.7	
200 M	-0.7		+0.7	
400 M	-0.7		+0.7	
600 M	-0.7		+0.7	
800 M	-0.7		+0.7	
1 G	-0.7		+0.7	
1.2 G	-1.5		+1.5	
1.4 G	-1.5		+1.5	
1.6 G	-1.5		+1.5	
1.8 G	-1.5		+1.5	
2.0 G	-1.5		+1.5	
2.2 G	-1.5		+1.5	

Performance Verification Test Record

22. Output Level Changeover Accuracy

Center Frequency(Hz)	Test Data		Specification			Result
	Output Level(dBm)	Reference Level(dBm)	Min.(dB)	Measured Value(dB)	Max.(dB)	
100 k	-10.0	-5.0	N/A	Reference	N/A	-
	0	5.0	-1.0		+1.0	
	-14.9	-9.9	-1.0		+1.0	
	-15.0	-10.0	-1.0		+1.0	
	-19.9	-14.9	-1.0		+1.0	
	-20.0	-15.0	-1.0		+1.0	
	-30.0	-25.0	-1.0		+1.0	
1 M	-10.0	-5.0	N/A	Reference	N/A	-
	0	5.0	-1.0		+1.0	
	-14.9	-9.9	-1.0		+1.0	
	-15.0	-10.0	-1.0		+1.0	
	-19.9	-14.9	-1.0		+1.0	
	-20.0	-15.0	-1.0		+1.0	
	-30.0	-25.0	-1.0		+1.0	
10 M	-10.0	-5.0	N/A	Reference	N/A	-
	0	5.0	-1.0		+1.0	
	-14.9	-9.9	-1.0		+1.0	
	-15.0	-10.0	-1.0		+1.0	
	-19.9	-14.9	-1.0		+1.0	
	-20.0	-15.0	-1.0		+1.0	
	-30.0	-25.0	-1.0		+1.0	
200 M	-10.0	-5.0	N/A	Reference	N/A	-
	0	5.0	-1.0		+1.0	
	-14.9	-9.9	-1.0		+1.0	
	-15.0	-10.0	-1.0		+1.0	
	-19.9	-14.9	-1.0		+1.0	
	-20.0	-15.0	-1.0		+1.0	
	-30.0	-25.0	-1.0		+1.0	
400 M	-10.0	-5.0	N/A	Reference	N/A	-
	0	5.0	-1.0		+1.0	
	-14.9	-9.9	-1.0		+1.0	
	-15.0	-10.0	-1.0		+1.0	
	-19.9	-14.9	-1.0		+1.0	
	-20.0	-15.0	-1.0		+1.0	
	-30.0	-25.0	-1.0		+1.0	
600 M	-10.0	-5.0	N/A	Reference	N/A	-
	0	5.0	-1.0		+1.0	
	-14.9	-9.9	-1.0		+1.0	
	-15.0	-10.0	-1.0		+1.0	
	-19.9	-14.9	-1.0		+1.0	
	-20.0	-15.0	-1.0		+1.0	
	-30.0	-25.0	-1.0		+1.0	
800 M	-10.0	-5.0	N/A	Reference	N/A	-
	0	5.0	-1.0		+1.0	
	-14.9	-9.9	-1.0		+1.0	
	-15.0	-10.0	-1.0		+1.0	
	-19.9	-14.9	-1.0		+1.0	
	-20.0	-15.0	-1.0		+1.0	
	-30.0	-25.0	-1.0		+1.0	
1 G	-10.0	-5.0	N/A	Reference	N/A	-
	0	5.0	-1.0		+1.0	
	-14.9	-9.9	-1.0		+1.0	
	-15.0	-10.0	-1.0		+1.0	
	-19.9	-14.9	-1.0		+1.0	
	-20.0	-15.0	-1.0		+1.0	
	-30.0	-25.0	-1.0		+1.0	
1.5 G	-10.0	-5.0	N/A	Reference	N/A	-
	0	5.0	-2.0		+2.0	
	-14.9	-9.9	-2.0		+2.0	
	-15.0	-10.0	-2.0		+2.0	
	-19.9	-14.9	-2.0		+2.0	
	-20.0	-15.0	-2.0		+2.0	
	-30.0	-25.0	-2.0		+2.0	
2.0 G Cont'd	-10.0	-5.0	N/A	Reference	N/A	-
	0	5.0	-2.0		+2.0	

Performance Verification Test Record

2.0 G	-14.9	-9.9	-2.0		+2.0	
	-15.0	-10.0	-2.0		+2.0	
	-19.9	-14.9	-2.0		+2.0	
	-20.0	-15.0	-2.0		+2.0	
	-30.0	-25.0	-2.0		+2.0	
2.2 G	-10.0	-5.0	N/A	Reference	N/A	-
	0	5.0	-2.0		+2.0	
	-14.9	-9.9	-2.0		+2.0	
	-15.0	-10.0	-2.0		+2.0	
	-19.9	-14.9	-2.0		+2.0	
	-20.0	-15.0	-2.0		+2.0	
	-30.0	-25.0	-2.0		+2.0	

23. Harmonic Distortion

Test Data		Specification			Result
Fundamental(Hz)	Second Harmonic(Hz)	Min.(dBc)	Measured Value(dBc)	Max.(dBc)	Pass/Fail
100 k	200 k				
200k	400 k				
500k	1 M				
1M	2 M				
2M	4 M				
5M	5 M				
10M	20 M				
20M	40 M				
50M	100 M				
100M	200 M				
200M	400 M				
500M	1 G				
1 G	2 G				
1.5 G	3 G				
2 G	4 G				
2.2 G	5 G				

Frequency Range	Specification			Result
	Min.(dBc)	Result	Max(dBc)	Pass/Fail
9 kHz to 2.2 GHz	20			

24. Non Harmonic Distortion

Frequency Range	Specification			Result
	Min.(dBc)	Result	Max(dBc)	Pass/Fail
9 kHz to 2.2 GHz	30			

25. TG Leakage

Frequency Range	Specification			Result
	Min.(dBm)	Measured Value(dBm)	Max(dBm)	Pass/Fail
9 kHz to 2.2 GHz	-95			

4. ADJUSTMENT PROCEDURE

This chapter provides following adjustment procedure.

4.1. 10 MHz reference oscillator adjustment.

4.1. 10 MHz Reference Oscillator Adjustment

Description

Apply 1 GHz output of signal generator referenced external signal standard. Then measure and adjust 1 GHz signal using U3661 frequency counter function to meet specification.

U3661's frequency counter measurement accuracy is referenced to 10 MHz reference oscillator.

Specification

Frequency	$\pm 2 \times 10 \text{ exp } -6$
	$\pm 2 \times 10 \text{ exp } -8$ for Option 20.

Equipment used

Signal Generator	:SG2
Frequency Standard	:Freq.STD.
RF Cables:	:BNC(m)-BNC(m)
RF Cable	:SMA(m)-SMA(m)
Adapter	:N(m) -SMA(f)

Setup

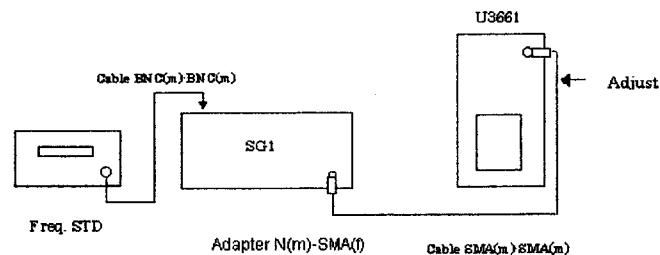

Figure 4-1 Setup of Frequency Reference Adjustment

4. ADJUSTMENT PROCEDURE

Procedure

1. Connect the equipment as shown in Figure 4-1.
2. On the SG1, set controls as follows:

FREQUENCY REFERENCE	:EXT
Frequency	:1 GHz
Output level	:-10 dBm

3. On the U3661, set controls as follows:

Center Frequency	:1 GHz
Span	:2 MHz
RBW	:30 kHz
Cont. peak	:ON
Counter	:ON
Counter Resolution	:10 Hz
	:(1 Hz for Option 20)

4. While monitoring frequency counter reading, adjust a potentiometer to meet specification. Location of potentiometer is shown in Figure 4-2.

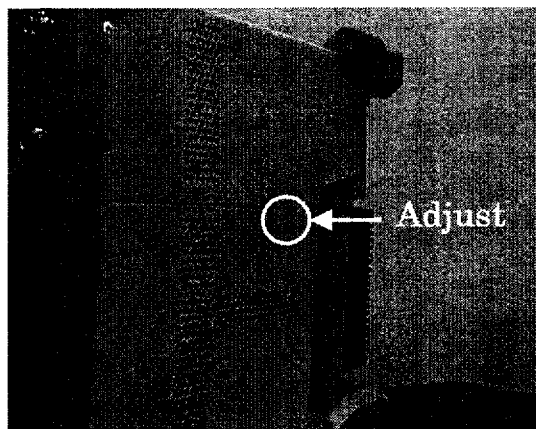

Figure 4-2 Location of Potentiometer

5. TROUBLESHOOTING

This chapter provides information of troubleshooting as followings:

5.1 Preparation

5.1.1 Introduction

5.1.2 General Caution for Handling Replaceable Assemblies (Blocks)

5.2 Isolation of Failure Block

5.2.1 Introduction

5.2.2 Isolation of failure

5.3 Procedure of Removal and Installation

5.1 Preparation

5.1.1 Introduction

This section provides general information for handling replaceable assemblies.

WARNING !

Only personnel with knowledge of electronic circuitry and awareness with hazards involved should remove and install any printed circuit board assemblies.

CAUTION !

To prevent equipment circuit damage, always remove the ac line power cord before removing or replacing any assembly.

To prevent static zap of ICs, always observe anti-static techniques when assemblies are handled or serviced.

5.1.2 General Caution for Handling Replaceable Assemblies

[STATIC HANDLING]

Static electricity is familiar phenomenon which, except for an occasional Shock, does not seem very serious. However, it has been proven that in the electronics industry electrostatic discharge (ESD) is major cause of component failure. In many cases, the component damaged may not immediately fail, causing low instrument reliability and future repair.

5. TROUBLESHOOTING

ESD damage can occur at static level below human perception. It has also been shown that

ESD can affect both passive and active devices.

The following guidelines are the minimum requirements for a static safe service environment.

- ◆ The workbench should be equipped with a conductive tablemat. The mat should be grounded to the earth ground through a 1M-ohm resistor. The mat should be equipped with at least one swivel connector for connecting wrist strap.
- ◆ All service and handling personnel should wear a conductive wrist strap in contact with bare skin.

This strap should be connected to the swivel connector on the conductive tablemat through a 1M Ω resistor.

- ◆ All the metal equipment at workstation must be grounded. This includes soldering irons, soldering removers, and equipment stand.
- ◆ Only one common ground should be provided at the workstation.
- ◆ The workstation should be kept free of nonconductors. No common plastics, polybags, cardboard, cigarette or candy wrappers should be allowed. There should not be rugs or carpet on the floor, shelving, or bench top.
- ◆ Only proper containers should be used for shipping, storing or transporting assemblies.

This is required on any assembly shipped to ADVANTEST for repair.

[CLEAN HANDLING]

Due to the high performance of the U3661, use the following clean handling techniques when removing and installing assemblies.

- ◆ Handle the assemblies only by their edges.
Be sure to place them on clean workbench away from dirty or dusty conditions.

5.2 Isolation of Failure Block

5.2.1 Introduction

This section provides information for isolating failure block.

To isolate failure block uses information of performance verification result.

During performance verification, if any fail result found, take a proper procedure to maintain U3661 performance.

5.2.2 Isolation of Failure Block

Table 5-1 shows the correspondence between performance verification items and failure blocks.

Table 5-2 shows the correspondence between performance verification items and failure block with option 74-Tracking Generator.

If found any fail result in the performance verification, take an action to fix.

Table 5-1 Correspondence between Performance Verification and Failure Block

No. of Performance Verification	Items	Failure Block	Action to be taken	Replacement Procedure
3.2.1	Reference Oscillator Accuracy	SYNTHE Block	Replace SYNTHE Block	Section 5.3.5
3.2.2	CAL OUT Amplitude Accuracy	RF Block	Replace RF Block	Section 5.3.3
3.2.3	Displayed Average Noise Level	RF Block	Replace RF Block	Section 5.3.3
3.2.4	RBW Switching Accuracy	IF Block	Replace IF Block	Section 5.3.4
3.2.5	RBW Accuracy	IF Block	Replace IF Block	Section 5.3.4
3.2.6	IF Gain Uncertainty	IF Block	Replace IF Block	Section 5.3.4
3.2.7	Input Attenuator Switching Accuracy	RF Block	Replace RF Block	Section 5.3.3
3.2.8	Scale Fidelity	LOG Block	Replace IF Block	Section 5.3.4
3.2.9	Residual FM	SYNTHE Block	Replace SYNTHE Block	Section 5.3.5
3.2.10	Noise Sidebands	RF Block	Replace RF Block	Section 5.3.3
3.2.11	Image, Multiple and Out band Spurious	RF Block	Replace RF Block	Section 5.3.3
3.2.12	Frequency Readout Accuracy	RF Block	Replace RF Block	Section 5.3.3
3.2.13	Second Harmonics Distortion	RF Block	Replace RF Block	Section 5.3.3
3.2.14	Frequency response	RF Block	Replace RF Block	Section 5.3.3
3.2.15	Span Accuracy Span > 2 MHz	RF Block	Replace RF Block	Section 5.3.3
3.2.15	Span Accuracy Span ≤ 2MHz	SYNTHE Block	Replace SYNTHE Block	Section 5.3.5
3.2.16	Third Order Intermodulation Distortion	RF Block	Replace RF Block	Section 5.3.3
3.2.17	Gain Compression	RF Block	Replace RF Block	Section 5.3.3
3.2.18	Sweep Time Accuracy	A/D Block	Replace A/D Block	Section 5.3.5
3.2.19	Residual Response	RF Block	Replace RF Block	Section 5.3.3

5. TROUBLESHOOTING

Table 5-2 Correspondences between Performance Verification and Failure Block with TG Option

No. of Performance Verification	Items	Failure Block	Action to be taken	Replacement Procedure
3.2.1	Reference Oscillator Accuracy	SYNTHE Block	Replace SYNTHE Block	Section 5.3.5
3.2.2	CAL OUT Amplitude Accuracy	RF Block	Replace RF Block	Section 5.3.3
3.2.3	Displayed Average Noise Level	RF Block	Replace RF Block	Section 5.3.3
3.2.4	RBW Switching Accuracy	IF Block	Replace IF Block	Section 5.3.4
3.2.5	RBW Accuracy	IF Block	Replace IF Block	Section 5.3.4
3.2.6	IF Gain Uncertainty	IF Block	Replace IF Block	Section 5.3.4
3.2.7	Input Attenuator Switching Accuracy	RF Block	Replace RF Block	Section 5.3.3
3.2.8	Scale Fidelity	Tracking Generator	Replace Tracking Generator Block	Section 5.3.4
3.2.9	Residual FM	SYNTHE Block	Replace SYNTHE Block	Section 5.3.5
3.2.10	Noise Sidebands	RF Block	Replace RF Block	Section 5.3.3
3.2.11	Image, Multiple and Out band Spurious	RF Block	Replace RF Block	Section 5.3.3
3.2.12	Frequency Readout Accuracy	RF Block	Replace RF Block	Section 5.3.3
3.2.13	Second Harmonics Distortion	RF Block	Replace RF Block	Section 5.3.3
3.2.14	Frequency response	RF Block	Replace RF Block	Section 5.3.3
3.2.15	Span Accuracy Span > 2 MHz	RF Block	Replace RF Block	Section 5.3.3
3.2.15	Span Accuracy Span ≤ 2MHz	SYNTHE Block	Replace SYNTHE Block	Section 5.3.5
3.2.16	Third Order Intermodulation Distortion	RF Block	Replace RF Block	Section 5.3.3
3.2.17	Gain Compression	RF Block	Replace RF Block	Section 5.3.3
3.2.18	Sweep Time Accuracy	A/D Block	Replace A/D Block	Section 5.3.5
3.2.19	Residual Response	RF Block	Replace RF Block	Section 5.3.3
3.2.20	Absolute Output Level Accuracy	Tracking Generator	Replace Tracking Generator Block	Section 5.3.4
3.2.21	Output Level Flatness	Tracking Generator	Replace Tracking Generator Block	Section 5.3.4
3.2.22	Output Level Switching Accuracy	Tracking Generator	Replace Tracking Generator Block	Section 5.3.4
3.2.23	Harmonic Distortion	Tracking Generator	Replace Tracking Generator Block	Section 5.3.4
3.2.24	Non-harmonic Distortion	Tracking Generator	Replace Tracking Generator Block	Section 5.3.4
3.2.25	TG Leakage	Tracking Generator	Replace Tracking Generator Block	Section 5.3.4

5.3 Procedure of Removal and Installation

5.3.1 Introduction

This section provides removal and installation procedures, after determined failure block.

5.3.2 Tools Required

Following tools are required for removal and Installation

Phillips Screw Driver (M4) 1 piece.

5.3.3 RF Block Removal and Installation

1. Turn off the power switch on the U3661, and then remove the main power supply cable.
2. Remove the carrying belt from U3661.
3. Remove 2 pcs screws on the both side of U3661, refer to Figure 5-1 and Figure 5-2.

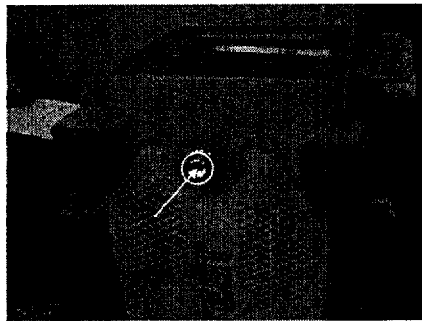

Figure 5-1 Location of Screw

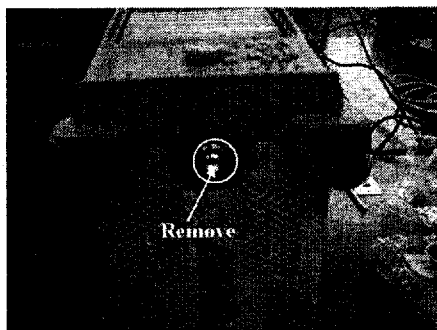

Figure 5-2 Location of Screw

5. TROUBLESHOOTING

4. Remove FRONT PANEL block, refer to Figure 5-3.

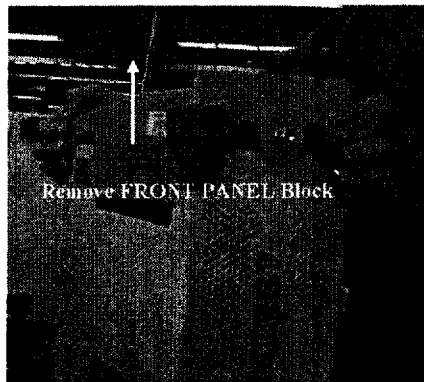

Figure 5-3 Removal of Front Panel Block

5. Remove fixing screws of RF Block on the bottom panel and rear panel, refer to Figure 5-4 and Figure 5-5.

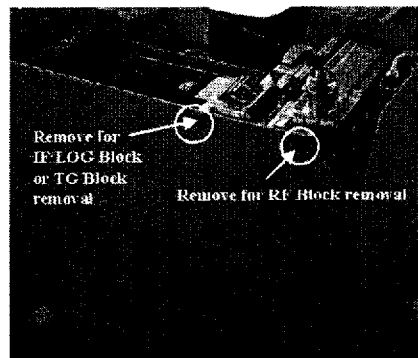

Figure 5-4 Location of Screw on the bottom

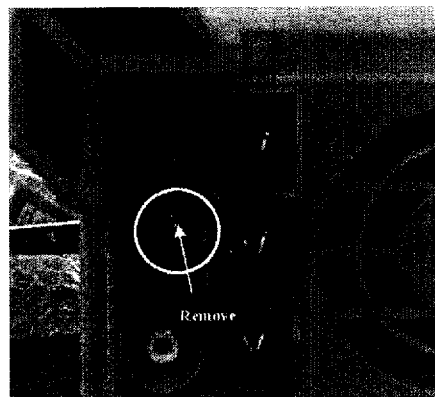

Figure 5-5 Location of Screw on the Rear Panel

6. Remove RF cable and pull RF block out, refer to Figure 5-6 and Figure 5-7.

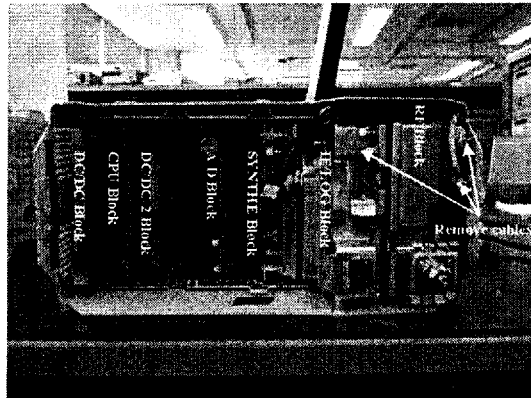

Figure 5-6 Locations of Blocks

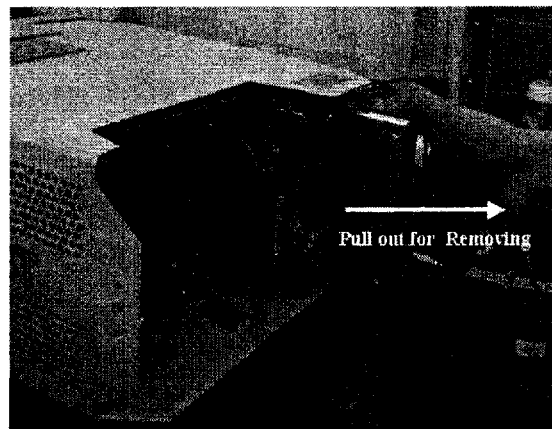

Figure 5-7 Removing RF Block

7. After removing defective block, replace with new one.
8. Use reverse procedure to fix back.

5.3.4 IF Block and LOG Block Removal and Installation

1. Use procedure steps 1 through 5 described in section 5.3.3.
2. Remove a screw as shown in Figure 5-4 on the bottom panel.
3. Pull out IF/LOG block for removal.
IF Block and LOG Block are combine together.
4. Separate IF block and LOG Block, removing screws as shown in Figure 5-8.

5. TROUBLESHOOTING

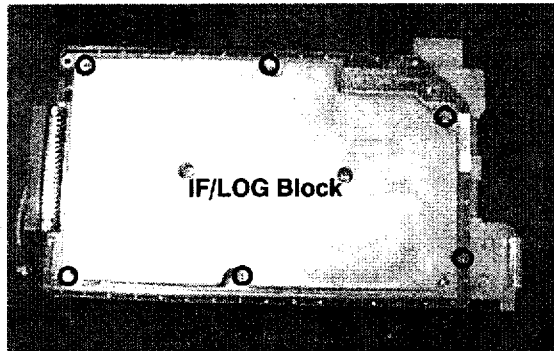

Figure 5-8 Locations of Screws

5. After separate, replace defective block with new one.
6. Use reverse procedure to fix back.

5.3.5 SYNTHE Block, A/D Block, DC/DC-2 Block CPU Block and DC/DC Block Removal and Installation Procedure

1. Use procedure steps 1 through 5 described in section 5.3.3.
2. Pull out defective block.
Location of blocks is shown in Figure 5-6.
3. Replace with new one.
4. Use reverse procedure to fix back.

5.3.6 TG Block Removal and Installation Procedure

1. Use procedure described in section 5.3.4.

6. REPLACEABLE PARTS

6.1. Introduction

This chapter provides information for ordering replaceable parts.

6.2. Ordering Information

To order a part listed in the replaceable parts list, quote Advantest part number, indicate the description, quantity required, including your Model Number and serial number.

Then address the order to the nearest Advantest office or representatives of Advantest in your region.

The office are listed in back of this manual.

6.3. Replaceable Parts List

The replaceable parts are listed in Table 6-1.

All the parts are for assemble replace with no adjustment.

Table 6-1 Replaceable Parts List

No.	Description	Parts Code
1	RF Block	WBL-3661*RF
2	SYNTH Block	WBL-3641SYNTH
3	IF Block	BLK-022288
4	LOG Block	WBL-3641*LOG
5	A/D Block	BLD-021055
6	CPU Block	BLD-023909
7	DC/DC Block	BLG-022286
8	DC/DC-2 Block	BLD-023910
9	FRONT Block	WBL-3661*FRONT
10	MAIN FLAME	WBL-3661*HONTAI
11	High Stability Reference Source	WBL-3641*OPT20
12	Narrow Band RBW	WBL-3641*OPT26
13	TV Demodulation	WBL-3641*OPT72
14	Tracking Generator	WBL-3641*OPT74

WARRANTY

ADVANTEST product is warranted against defects in material and workmanship for a period of one year from the date of delivery to original buyer.

LIMITATION OF WARRANTY

The foregoing warranty shall not apply to defects resulting from improper or inadequate maintenance by buyer, unauthorized modification or misuse, accident or abnormal conditions of operations.

No other warranty is expressed or implied. ADVANTEST specifically disclaims the implied warranties of merchantability and fitness for a particular purpose.

ADVANTEST shall not be liable for any special incidental or consequential damages, whether in contract, tort or otherwise.

Any and all warranties are revoked if the product is removed from the country in which it was originally purchased.

SERVICE

During the warranty period, ADVANTEST will, at its option, either repair or replace products which prove to be defective.

When trouble occurs, buyer should contact his local supplier or ADVANTEST giving full details of the problem and the model name and serial number.

For the products returned to ADVANTEST for warranty service, buyer shall prepay shipping and transportation charges to ADVANTEST and ADVANTEST shall pay shipping and transportation charges to return the product to buyer. However, buyer shall pay all charges, duties, and taxes incurred in his country for products returned from ADVANTEST.

CLAIM FOR DAMAGE IN SHIPMENT TO ORIGINAL BUYER

The product should be thoroughly inspected immediately upon original delivery to buyer. All material in the container should be checked against the enclosed packing list or the instruction manual alternatively. ADVANTEST will not be responsible for shortage unless notified immediately.

If the product is damaged in any way, a claim should be filed by the buyer with carrier immediately. (To obtain a quotation to repair shipment damage, contact ADVANTEST or the local supplier.) Final claim and negotiations with the carrier must be completed by buyer.

SALES & SUPPORT OFFICES

Advantest(Singapore)Pte.Ltd.

438A Alexandra Road

#08-03/06 Alexandra Technopark Singapore 119967

Phone : 65-274-3100 Facsimile : 65-274-4055

ROHDE & SCHWARZ Engineering and Sales GmbH

Mühldorfstr. 15 (P.O.B. 80 1429, D-81614 Munichen)

D-81671 Munichen, Germany

Phone : 49-89-4129-13711 Facsimile : 49-89-4129-13723

TEKTRONIX INC.

P.O. Box 500, M/S 39-520, Beaverton, Oregon 97077-0001

or

Howard Vollum Industrial Park, M/S 58-743, Beaverton, OR, 97077, U.S.A.

Inside the U.S. 1-800-426-2200

Outside the U.S. 1-503-627-1933

— Technology Support on the Leading Edge —

ADVANTEST[®]

ADVANTEST CORPORATION

