

**R8340/8340A**  
Digital Ultra High Resistance/  
Micro Current Meters

INSTRUCTION MANUAL

**OPERATIONS**

**ADVANTEST®**  
ADVANTEST CORPORATION

---

---

**ADVANTEST®**  
ADVANTEST CORPORATION

---

**R8340/8340A**

*Digital Ultra High Resistance/*

*Micro Current Meters*

**INSTRUCTION MANUAL**



MANUAL NUMBER OED00 9302

---

Before reselling to other corporations  
or re-exporting to other countries, you  
are required to obtain permission from  
both the Japanese Government under its  
Export Control Act and the U.S. Govern-  
ment under its Export Control Law.

# NOTICE

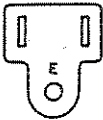
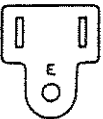
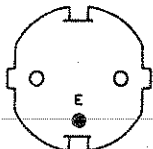
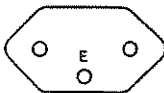
ADVANTEST provides the following power cables for each country.  
If there was any inconvenience on your use, please contact our subsidiaries or ADVANTEST representatives.

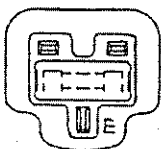
	Plugs	Standards/Countries	Ratings/Color/ Length	Accessory Codes
1		JIS : JAPAN	Rating :125V 7A Color :Black Length :2m	A01402 A01412
2		UL : USA CSA : CANADA	Rating :125V 7A Color :Black Length :2m	A01403 (Opt.95) A01413
3		CEE : EUROPE VDE : FRG OVE : AUSTRIA SEMKO : SWEDEN DEMKO : DENMARK KEMA : NETHERLANDS FIMKO : FINLAND NEMKO : NORWAY CEBEC : BELGIUM	Rating :250V 6A Color :Gray Length :2m	A01404 (Opt.96) A01414
4		SEV : SWITZERLAND	Rating :250V 6A Color :Gray Length :2m	A01405 (Opt.97) A01415
5		SAA : AUSTRALIA NEWZELAND	Rating :250V 6A Color :Gray Length :2m	A01406 (Opt.98)
6		BS : UK	Rating :250V 6A Color :Black Length :2m	A01407 (Opt.99) A01417

Note : "E" shows earth (ground).

## Table of Contents

1. INTRODUCTION .....	1 - 1
1.1 How to Use the Operation Manual .....	1 - 2
1.2 Outline of the Meter .....	1 - 4
1.3 Before Operating Meter .....	1 - 5
1.3.1 Checking Accessories .....	1 - 5
1.3.2 Operating Ambient Conditions .....	1 - 6
1.3.3 Supply Voltage .....	1 - 7
1.3.4 Power Cable .....	1 - 8
1.3.5 Fuse .....	1 - 9
1.3.6 Input/Output Cable .....	1 - 10
1.3.7 Preheating Time .....	1 - 10
2. DESCRIPTION OF METER PANEL .....	2 - 1
2.1 Marking Safety Symbols .....	2 - 2
2.2 Description of Front Panel .....	2 - 3
2.3 Display Panel on Front Panel .....	2 - 8
2.4 Description of Rear Panel .....	2 - 9
3. HOW TO OPERATE .....	3 - 1
3.1 Measurement Preparation .....	3 - 2
3.1.1 Power On .....	3 - 2
3.1.2 Various Messages .....	3 - 4
3.1.3 Table of Initialize Setting States .....	3 - 9
3.2 Basic Operation Method .....	3 - 11
3.2.1 How to Use Short bar of Earthed/Isolated .....	3 - 11
3.2.2 Discharge, Charge, and Measure .....	3 - 15
3.2.3 DC Measurement (IM) .....	3 - 17
3.2.4 Voltage Applying Current Measurement (VSIM) .....	3 - 17
3.2.5 Resistance Measurement (VSRM) .....	3 - 22
3.2.6 Measurement of Volume Resistivity and Surface Resistivity .....	3 - 26
3.3 Various Functions .....	3 - 33
3.3.1 Null .....	3 - 33
3.3.2 Compare .....	3 - 34
3.3.3 Integration Time .....	3 - 35
3.3.4 AD CAL .....	3 - 35
3.3.5 Input Amplifier Gain .....	3 - 36
3.3.6 Current Limiter (Current Compliance) .....	3 - 40
3.3.7 Auto Range Up/Down Level .....	3 - 41
3.3.8 Contact Checking .....	3 - 43
3.3.9 Trigger Delay .....	3 - 50
3.3.10 Autorange Delay .....	3 - 51
4. DESCRIPTION OF PARAMETER KEYS .....	4 - 1
4.1 Basic Usage of Parameter Keys .....	4 - 2
4.2 Various MEAS-Key Setting Methods .....	4 - 8
4.2.1 Integral Time .....	4 - 8
4.2.2 AD CAL .....	4 - 10
4.2.3 Input Amplifier Gain .....	4 - 11
4.2.4 Current Limiter (Current Compliance) .....	4 - 12
4.2.5 Auto Range Up/down Level .....	4 - 13
4.2.6 Unit Indication .....	4 - 14

4.2.7	Trigger Delay	4 - 15
4.2.8	Autorange Delay	4 - 16
4.3	Various CAL-Key Setting Methods	4 - 17
4.3.1	Zero Cancel	4 - 17
4.3.2	Contact Initialization Offset Measurement	4 - 18
4.3.3	Contact Initialization	4 - 19
4.3.4	Self-test	4 - 20
4.4	Various COEF-Key Setting Methods	4 - 22
4.4.1	Upper Level	4 - 22
4.4.2	LOWER Level	4 - 26
4.4.3	Resistance Measurement Indication	4 - 30
4.4.4	Setting of Volume-/Surface Resistivity Electrode	4 - 31
4.4.5	Optional Electrode Coefficient	4 - 32
4.4.6	Sample Thickness	4 - 34
4.4.7	Contact Level	4 - 35
4.4.8	Buzzer	4 - 37
4.4.9	Data Indicator	4 - 38
4.4.10	Contact Initial Integral Time	4 - 39
4.5	Various I/O-Key Setting Methods	4 - 41
4.5.1	DA OUTPUT (R8340A Only)	4 - 41
4.5.2	BCD OUTPUT (R8340A Only)	4 - 43
4.5.3	GPIB	4 - 44
4.5.4	Power Frequency	4 - 46
4.6	Various MEM-Key Setting Methods	4 - 47
4.6.1	Data Storage	4 - 47
4.6.2	Data Recall	4 - 49
5.	SEQUENCE PROGRAM	5 - 1
5.1	Sequence	5 - 2
5.2	Execution of Sequence Program	5 - 8
5.3	Setting of Program Parameters	5 - 12
5.4	Sequence Program Operation Example	5 - 19
6.	GPIB INTERFACE	6 - 1
6.1	Outline	6 - 2
6.2	GPIB Standard	6 - 3
6.3	Connection with Component Units	6 - 5
6.4	Address Setting and Header on/off Selection	6 - 6
6.5	Talker Specification (Data Output)	6 - 7
6.5.1	Basic Format	6 - 7
6.5.2	Response to Query Command	6 - 9
6.5.3	Binary Packed Format	6 - 11
6.5.4	Format of Recall Data with Data Number	6 - 12
6.6	Listener Specification	6 - 14
6.6.1	Header Part	6 - 14
6.6.2	Data Part	6 - 15
6.6.3	Terminator	6 - 15
6.6.4	Query Command	6 - 15
6.6.5	Command Buffer and Measured Data Buffer	6 - 24
6.6.6	Controller Interruption During Data Transfer Between Units	6 - 24
6.7	Status Byte	6 - 25
6.7.1	Structure of Status Byte Register	6 - 25
6.7.2	Structure of Standard Event Status Register	6 - 28

6.7.3	Structure of Device Event Status Register .....	6 - 30
6.7.4	Error Register .....	6 - 32
6.7.5	Self-test Error Register .....	6 - 33
6.8	Status at Initialization and Command Reception .....	6 - 34
6.9	Program Example .....	6 - 35
7.	INPUT/OUTPUT SIGNALS .....	7 - 1
7.1	Handler Interface .....	7 - 2
7.2	COMPLETE Output Signal .....	7 - 9
7.3	TRIGGER Input Signal .....	7 - 10
7.4	LID SIGNAL Input Signal .....	7 - 11
8.	BCD OUTPUT AND D/A OUTPUT (R8340A ONLY) .....	8 - 1
8.1	Selection of BCD OUTPUT .....	8 - 2
8.1.1	BCD Output .....	8 - 2
8.1.2	Binary Output .....	8 - 7
8.2	D/A Output .....	8 - 10
9.	TROUBLESHOOTING AND CALIBRATION .....	9 - 1
9.1	Before Requesting Repair .....	9 - 2
9.2	Calibration .....	9 - 3
9.2.1	Preparation and Precaution for Calibration .....	9 - 3
9.2.2	Calibration Data Initialization .....	9 - 5
9.2.3	Calibration Method .....	9 - 6
10.	DESCRIPTION OF OPERATION .....	10 - 1
10.1	Outline of Operation .....	10 - 2
10.2	IV Converter .....	10 - 4
10.3	A/D Converter .....	10 - 5
11.	CONNECT INPUT/OUTPUT CABLES .....	11 - 1
11.1	Connection the Instrument to R12702A/B .....	11 - 2
11.2	Connection the Instrument to R12704 .....	11 - 4
11.3	Connection the Instrument to TR42 .....	11 - 5
11.4	Connecting the Instrument to TR43C .....	11 - 7
11.5	Connecting the Instrument to TR44 .....	11 - 9
11.6	Connecting the Instrument to R12706A .....	11 - 10
11.7	Connecting Multiple Samples with R12705A, R7210 and R72101J .....	11 - 12
11.8	Connecting the Instrument to R12604 .....	11 - 15
12.	SPECIFICATION .....	12 - 1
12.1	Direct Current Measurement .....	12 - 2
12.2	Resistance Measurement .....	12 - 3
12.3	Input Specification .....	12 - 4
12.4	Direct Current Generation .....	12 - 5
12.5	Measurement Speed and Maximum Indication .....	12 - 7
12.6	Input/Output Function .....	12 - 8
12.7	Other Function .....	12 - 9
12.8	General Specification .....	12 - 10
12.9	Accessories (Optional) .....	12 - 11

APPENDIX .....	A1 - 1
A1.1 GPIB Remoto Execution Time (representative value).....	A1 - 2
INDEX .....	I - 1
EXTERNAL VIEW	

LIST OF ILLUSTRATIONS

Figure No.	Title	Page
1 - 1	Operating Ambient Conditions	1 - 6
1 - 2	Set Supply Voltage Marked on Rear Panel	1 - 7
1 - 3	Plug and Aadapter of Power Cable	1 - 8
1 - 4	Structure of Input/Output Cable	1 - 10
2 - 1	Safety-symbol Marking Position on Meter Panel	2 - 2
2 - 2	Description of Front Panel	2 - 10
2 - 3	Description of Display Panel on Front Panel	2 - 10
2 - 4	Description of Rear Panel	2 - 10
3 - 1	Connection of Isolated Sample	3 - 11
3 - 2	Connection of Earthed Sample for Current Measurement	3 - 12
3 - 3	Connection of Earthed Sample for Resistance Measurement and VSIM	3 - 13
3 - 4	Connection for Coexistence of Isolated and Earthed Smples	3 - 14
3 - 5	Basic Flow of Operation	3 - 15
3 - 6	Equivalent Circuit Under Discharge, Charge, and Measure States	3 - 16
3 - 7	Basic Measurement	3 - 16
3 - 8	Electrode Connection (For volume resistivity measurement)	3 - 28
3 - 9	Electrode Connection (For surface resistivity measurement)	3 - 29
3 - 10	AD CAL Timing	3 - 35
3 - 11	Timing When Measurement Starts During Execution of AD CAL Function	3 - 36
3 - 12	Equivalent Circuit for Measurement of Capacitor Leak Current	3 - 36
3 - 13	Feedback-system Equivalent Circuit	3 - 37
3 - 14	Charge and Discharge Speed	3 - 41
3 - 15	Contact Checking	3 - 43
3 - 16	Trigger Delay	3 - 50
3 - 17	Autorange Delay	3 - 51
4 - 1	Basic Usage of Parameter Keys	4 - 7
6 - 1	GPIO Connector Pin Arrangement	6 - 3
6 - 2	Signal Conductor Termination	6 - 3
6 - 3	Structure of Status Byte Register	6 - 26
6 - 4	Standard Event Status Register	6 - 28
6 - 5	Device Event Status Register	6 - 30
7 - 1	Description of Handler Interface Connector Pins	7 - 2
7 - 2	LID SIGNAL Timing	7 - 3
7 - 3	Handler Interface Timing	7 - 4
8 - 1	Description of BCD Data Output Connection Pins	8 - 2
8 - 2	Description of Binary-output Connector Pins	8 - 9
8 - 3	Output Voltage of DA OUTPUT	8 - 10



Figure No.	Title	Page
9 - 1	Key Functions in Calibration Mode .....	9 - 6
9 - 2	Connection for Current Measurement Calibration .....	9 - 17
9 - 3	Connection for Voltage Generation Calibration .....	9 - 19
10 - 1	Block Diagram of R8340 and R8340A .....	10 - 3
10 - 2	IV Converter .....	10 - 4
10 - 3	Outline of A/D Converter Operation .....	10 - 5
11 - 1	R12702A/B Setup .....	11 - 2
11 - 2	R12702A/B Connecting Diagram .....	11 - 3
11 - 3	R12704 Setup .....	11 - 4
11 - 4	R12704 Connecting Diagram .....	11 - 4
11 - 5	TR42 Setup (Measuring volume resistance) .....	11 - 5
11 - 6	TR42 Setup (Surface resistance) .....	11 - 6
11 - 7	TR42C Setup .....	11 - 7
11 - 8	TR42 or 43C Connecting Diagram .....	11 - 8
11 - 9	TR44 Setup .....	11 - 9
11 - 10	Installation Terminals .....	11 - 10
11 - 11	R12706A Setup .....	11 - 10
11 - 12	R12706A Connecting Diagram .....	11 - 11
11 - 13	Installation Terminals .....	11 - 12
11 - 14	R12705A, R7210, and R72101J Setup .....	11 - 13
11 - 15	R12705A, R7210, and R72101J Connection Diagram .....	11 - 14
11 - 16	R12604 Setup .....	11 - 15

## LIST OF TABLES

Table No.	Title	Page
1 - 1	Standard Accessories .....	1 - 5
1 - 2	Fuse Specification .....	1 - 9
2 - 1	Safety Symbols .....	2 - 2
2 - 2	Parameter Key Functions .....	2 - 6
3 - 1	Error Messages .....	3 - 8
3 - 2	Electrode Dimensions Specified in JIS .....	3 - 26
3 - 3	COMPARE Operation Results and Indication .....	3 - 34
3 - 4	Input Resistance and Input Voltage Drop for Full Scale .....	3 - 39
3 - 5	Output Voltage and Current Limiter .....	3 - 40
3 - 6	Setting Range and Count Values .....	3 - 42
3 - 7	Status Fluctuations Due to Level Selection While Measuring 13.142nA (when the input resistance is GAINXI) .....	3 - 42
3 - 8	Contact Checking Judgment Level Range and Step Voltage .....	3 - 46
3 - 9	The Range Where Comparison of Contact Initial and Contact Check is Available .....	3 - 48
3 - 10	Delay Time in Each Range when Setting Autorange Delay .....	3 - 52
4 - 1	Parameter Keys .....	4 - 2
4 - 2	Parameter Key Function .....	4 - 3
4 - 3	Setting Contact Initial Integral Time Per Noise level .....	4 - 39
5 - 1	Keys Effective for Each Mode .....	5 - 10
5 - 2	Status Change of Each Mode .....	5 - 11
5 - 3	CAL Key Function (In program mode) .....	5 - 12
6 - 1	Interfaces and Their Functions .....	6 - 4
6 - 2	Standard Bus Cable .....	6 - 5
6 - 3	Mantissa- and Exponent-part Data .....	6 - 8
6 - 4	Program Code .....	6 - 16
6 - 5	Status Byte Register .....	6 - 27
6 - 6	Standard Event Status Register .....	6 - 29
6 - 7	Device Event Status Register .....	6 - 31
6 - 8	Error Register .....	6 - 32
6 - 9	Self-test Error Register .....	6 - 33
6 - 10	Status Change by Each Command .....	6 - 34
8 - 1	Data Output Codes .....	8 - 5
8 - 2	Data Output Example .....	8 - 6
9 - 1	Troubleshooting Items .....	9 - 2
9 - 2	Equipment Necessary for Calibration .....	9 - 3
9 - 3	Cables Necessary for Calibration .....	9 - 4
9 - 4	Setting of Standard Direct-current Generator for Calibration .....	9 - 20
9 - 5	Each Calibration Item Setting Range .....	9 - 21
9 - 6	Calibration Checking Error Range .....	9 - 23
11 - 1	Coefficient Setting .....	11 - 9

## 1. INTRODUCTION

This section describes the configuration of the operation manual, outline of the meter, and precautions for operation. Therefore, be sure to read the manual before operating the meter.

## 1.1 How to Use the Operation Manual

## (1) Configuration of the Operation Manual

1. Introduction	The outline of the meter and precautions for operation are described be sure to read this section before operating the meter.
2. Description of Meter Panel	Each part of the front and rear panels and safety symbols on the panels are described.
3. How to Operate	The measurement preparation and basic operation method and described.
4. Description of Parameter Keys	The parameter keys are described.
5. Sequence program	Sequence program creation, program execution and program parameter settings are described.
6. GPIB (General Purpose Interface Bus)	How to control the meter using the GPIB is described.
7. Input/Output Signals	Four types of input/output signals for control are described.
8. BCD Output and D/A Output	This function is given to the R8340A.
9. Checking and Calibration	The methods are described to check the meter when a trouble occurs during operation and to calibrate the meter to hold the measuring accuracy.
10. Description of Operation	The outline of the meter operation theory is described.
11. Applied Measurement	The measurement methods are described when the meter is combined with a fixture or scanner.
12. Specification	The standards and accessories(optional) of the meter are summarized.
APPENDIX	The GPIB remote execution time is described.

External View

External view of meter with dimensions is shown.

(2) This manual shows the display panel conditions as follows:

Example:

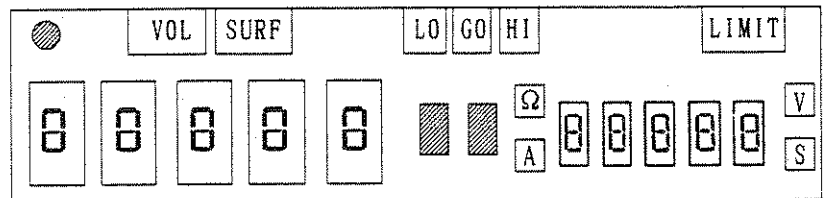
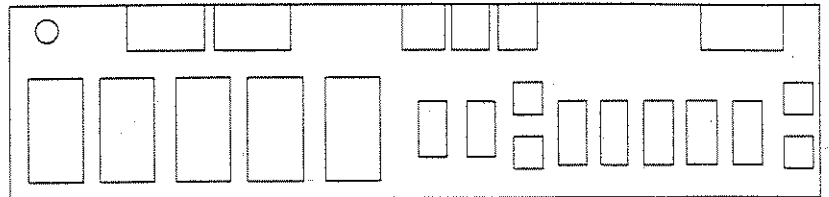

1)

## 1.2 Outline of The Meter

The R8340 and R8340A are the digital ultra-high-resistance/micro-current meter storing a voltage generation source of 0 to 1000V respectively.

The current measurement range is 10fA to 19.999mA and the resistance measurement range is 10 to  $3 \times 10^{16} \Omega$ .

The meter can easily measure large resistance at a high speed because it has such intelligent functions as contact checking and sequence program in addition to high-speed measurement of 100 samples/sec.

The R8340A is normally equipped with BCD (binary-coded decimal notation) output and D/A (digital to analog conversion) output.

### [Features]

- ① High-resolution and wide-range measurement  
Current : 10fA to 19.999mA  
Resistance :  $10 \Omega$  to  $3 \times 10^{16} \Omega$
- ② High-speed charge and discharge with the voltage source realizing 10W-class sink  
0V to 30V :  $\pm 0.3A$   
30V to 100V :  $\pm 0.1A$   
100V to 1000V :  $\pm 0.01A$
- ③ Sequence program function :  
Stores the measurement based on JIS C5102 (Test Methods of Fixed Capacitors for Electric Equipment).
- ④ Contact checking function :  
Checks sample connected conditions.
- ⑤ Integral-time varying function :  
Realizes high-speed (100 samples/sec) and high-accuracy measurement.
- ⑥ Operation function :  
Computes NULL, COMPARE, volume resistivity, and surface resistivity.
- ⑦ Data storing function :  
Stores up to 1000 data values.
- ⑧ The R8340 realizes 550-VDC floating measurement and the R8340A realizes 1100-VDC floating measurement.
- ⑨ A handler interface is normally installed to control the auto handler and fixture.
- ⑩ The GPIB is normally installed.

### 1.3 Before Operating Meter

#### 1.3.1 Checking Accessories

When the meter is delivered to you, check the following.

Check

- ① Check if the meter surface is damaged.
- ② Check the quantity and specification of the standard accessories according to Table 1-1.

In the event of any damage, missing standard accessory, or equivalent, contact a nearby sales office, or your dealer.

Notice : For additional order of accessories, designate the model (or stock No.).

Table 1 - 1 Standard Accessories

Product Name	Model	Stock No.	Quantity	Remarks
Power Cable	A01402	DCB-DD2428X01	1	
Input/Output	A01019-100	DCB-FM3526X02	1	For R8340
Cable	A01018-100	DCB-FM3525X02		For R8340A
Power Fuse	0.8A slow-blow fuse (EAWK 0.8A)	DFT-AAR8A	2	For specification of 100, 115, or 120 VAC
	0.4A slow-blow fuse (EAWK 0.4A)	DFT-AAR4A		For specification of 220, 230, or 240 VAC
Input Protection Fuse	1A slow-blow fuse (EAWK 1A)	DFT-AA1A	2	
Operation Manual	—	JR8340/8340A	1	Japanese Version
	—	ER8340/8340A		English Version

1.3.2 Operating Ambient Conditions

- (1) Operate the meter at the place free from dust, vibration, direct sunlight or corrosive gas. Keep the ambient temperature between 0 and 40°C and the relative humidity at 85% or less.
- (2) The meter uses a discharge-type cooling fan to avoid internal temperature rise. Therefore, keep the meter 10cm or more from the wall and things behind the meter to improve ventilation. Do not place any thing closely to the back of the meter, stand the meter, or interrupt the top or bottom ventilating hole.
- (3) Though the meter is designed by adequately considering noises from the AC power line, operate it by minimizing noises. If noises cannot be avoided, use a noise elimination filter.
- (4) Store the meter by keeping temperature between -25°C and +70°C. When the meter is not used for a long time, store it at a dry place free from sunlight by covering it with a vinyl sheet or putting it in a carton.
- (5) When transporting the meter, use the packing materials which are first delivered to you. If you do not have the packing materials, pack the meter as follows.
  - ① Cover the meter with vinyl sheet.
  - ② Put the meter in a carton with the thickness of 5mm or more together with a cushioning material so that the meter will be wrapped by the cushion.
  - ③ Then put accessories in the carton together with the cushioning material after wrapping the meter with the cushion, close the carton, and secure the carton surface with a packing string.

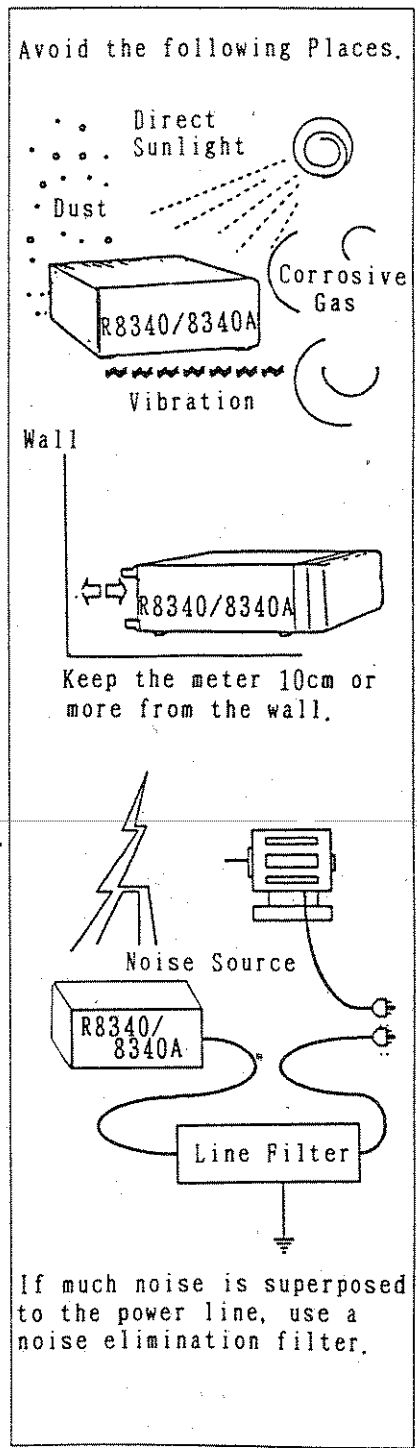

Figure 1 - 1 Operating Ambient Conditions



### 1.3.3 Supply Voltage

Before connecting the power cable, be sure to check if the power switch is turned off.

The supply voltage is factory-set and marked on the rear panel. (See Figure 1-2.) Check if the supply voltage to be used is matched with the displayed value.

Use 50 or 60Hz for the power frequency.

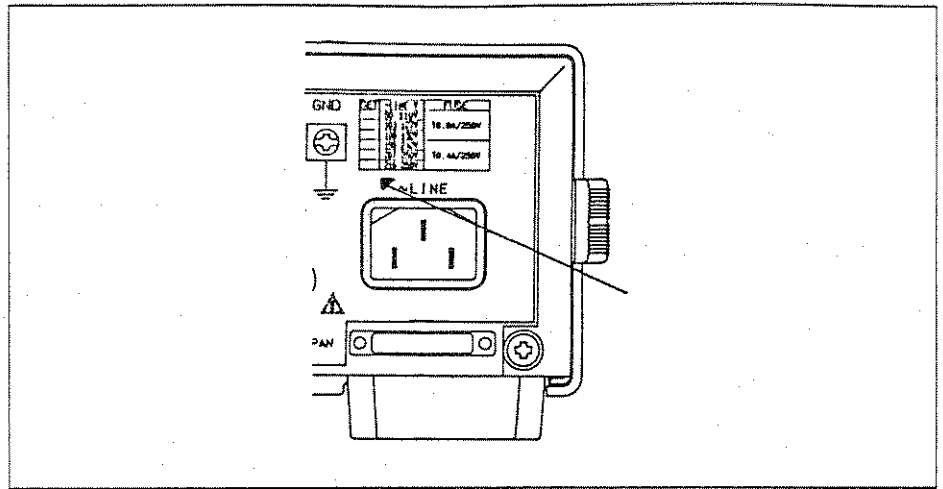

Figure 1 - 2 Set Supply Voltage Marked On Rear Panel

### 1.3.4 Power Cable

The power cable plug has three pins and the round pin is used for earthing. See Figure 1-3 (a). Use the outlet equipped with an earth terminal. When using a 2 pin plug, connect it to the outlet using the adapter A09034 attached to the plug. In this case, be sure to connect the earth lead wire extended from the adapter or the GND terminal on the rear panel with the external earth terminal or to earth it to the ground.

To insert the adapter A09034 into the outlet, confirm the directions of the plug and the outlet because two electrodes of the adapter are different in width as shown in Figure 1-3(b).

If the adapter A09034 cannot be connected to the outlet used, use the adapter KPR-13 (separately sold product).

#### CAUTION

Carefully connect the earth wire extended from the adapter so that the wire will not contact the AC power supply.

If the wire is carelessly contacted to the AC power supply, the meter or other connected equipment may be damaged.

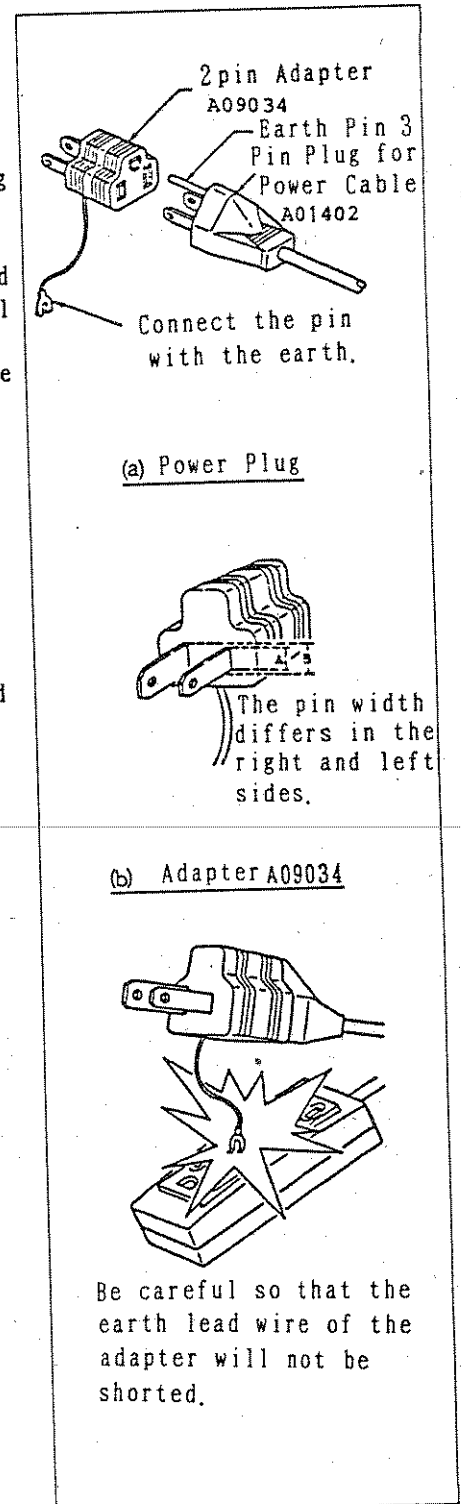

Figure 1 - 3 Plug and Adapter of Power Cable

### 1.3.5 Fuse

#### (1) Power Fuse and input Protection Fuse

The meter has a power fuse and an input protection fuse to protect the internal circuit under charge/discharge states. The power fuse is installed on the rear panel and the input protection fuse is housed in the fuse holder on the front panel.

#### (2) How to Replace Fuse

**CAUTION**

1. Be sure to turn off the power switch and remove the power cable from the outlet before replacing fuses.
2. Not only visually check each fuse but measure the resistance of each fuse. A fuse is normal when its resistance is 15  $\Omega$  or less.

#### Operation (① through ③)

- ① When slightly pressing a slotted screwdriver against the fuse holder cap to turn it approx. 60 $^{\circ}$  counterclockwise and releasing it, the rotary element is protruded approx. 3mm toward you.
- ② Pull out the rotary element to replace the installed fuse with a new one.
- ③ Re-install the rotary element by pressing the screwdriver against the element and turning it approx. 60 $^{\circ}$  clockwise. Shows the Fuse Specification.

Table 1 - 2 Fuse Specification

Fuse	Specification		Remarks
	Model	Stock No.	
Power Fuse	0.8A slow-blow fuse (BAWK0.8A)	DFT-AAR8A	For specification of 100, 115, or 120 VAC
	0.4A slow-blow fuse (BAWK0.4A)	DFT-AAR4A	For specification of 220, 230, or 240 VAC
Input protection fuse	1A slow-blow fuse (BAWK1A)	DFT-AA1A	

**WARNING**

For constant protection from fire, use the fuse with the same type and rating.

### 1.3.6 Input/Output Cable

Use the attached input/output cable A01019 for the R8340 and the A01018 for the R8340A.  
The input/output cable is a double-coaxial cable. Figure 1-4 shows the cable structure.  
Connect the triaxial connector with the INPUT terminal and the banana tip with the LO or V-SOURCE terminal.  
The triaxial connector A01019 has the dielectric strength of 550 VDC and the A01018 has that of 1100 VDC.  
When the floating measurement of 550 VDC or more is necessary for measurement of earthed samples, use the meter R8340A and the cable A01018.  
For how to connect the input/output cable, see Item 3.2.1

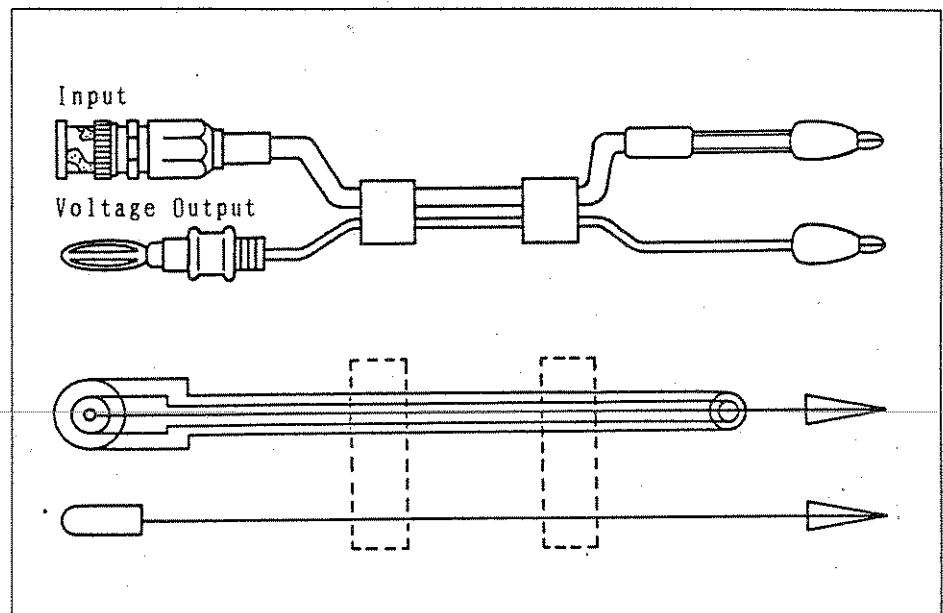

Figure 1 - 4 Structure of Input/Output Cable

### 1.3.7 Preheating Time

Though all functions of the meter start as soon as the power is turned on, it is recommended to take the preheating time of 30 min or more to obtain the specified accuracy.





## 2. DESCRIPTION OF METER PANEL

This section describes each part of the front and rear panels and the safety symbols marked on the panel surface.

## 2.1 Marking Safety Symbols

The following is the description of each safety symbol marked on the front and rear panels. Table 2-1 shows the meaning of various safety symbols and Figure 2-1 shows the safety-symbol marking positions on the meter panel.

Table 2 - 1 Safety Symbols

No.	Symbol	Name	Description
①		Warning symbol	This is marked on the positions where it is needed to see the operation manual to protect the meter from being damaged.
②		Flash symbol	This shows dangerous high voltage. The symbol is marked on the terminals outputting a voltage exceeding 1kV.
③		Earth terminal symbol	This is marked on general earth terminals. Connect the terminals with the ground.
④		AC power supply symbol	This shows an AC power supply.

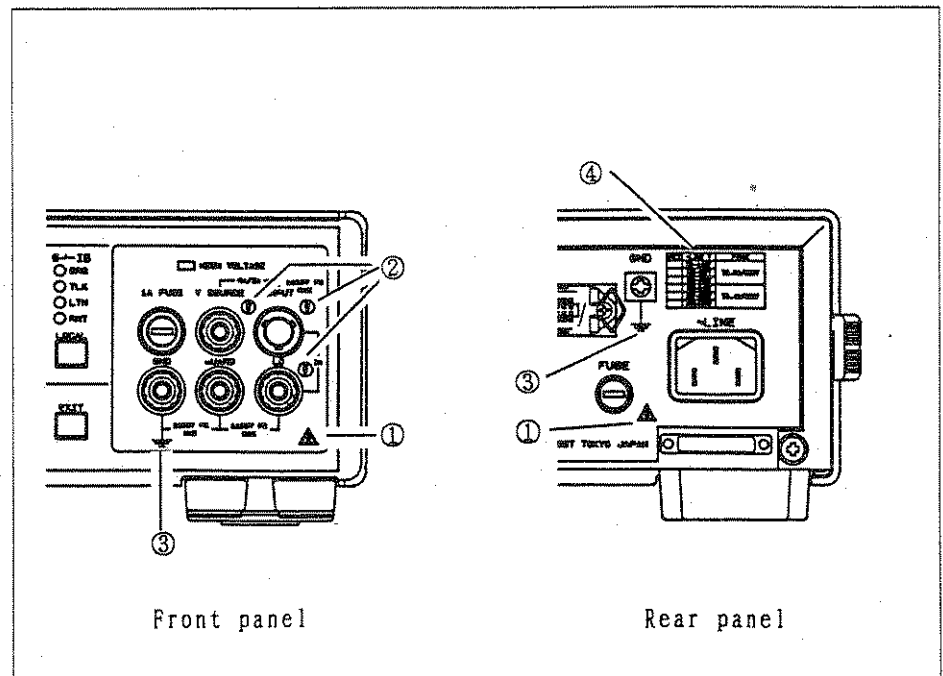

Figure 2 - 1 Safety-symbol Marking Position on Meter Panel

## 2.2 Description of Front Panel

Figure 2-2 shows the front panel. Each part is described in order of numbers ① through ⑫ on the panel surface. The R8340 and R8340A are the same other than the marking of R8340 instead of R8340A and the dielectric strength of the LO to GUARD terminals.

- ① POWER switch : Used to turn on/off the power.
- ② IM/RM key : Used to select the current or resistance value.  
In the numerical value input mode, the input key "0" is effective.
- ③ AUTO key : Used to select the auto or manual range. When the auto range is set, the LED on the key lights.  
In the numerical value input mode, the input key "1" is effective.
- ④ DOWN key : Used to lower the current measuring range by one step from the present level.  
In the numerical value input mode, the input key "2" is effective.
- ⑤ UP key : Used to raise the current measuring range by one step from the present level.  
In the numerical value input mode, the input key "3" is effective.

### CAUTION

To measure resistance, change the range using the current measuring range.

When pressing the DOWN or UP key, the range is changed in the direction opposite to current measurement.

- ⑥ RUN/HOLD key : Used to select FREE RUN or HOLD for sampling. When FREE RUN is set, the LED on the key lights.  
In the numerical value input mode, the input key "4" is effective.
- ⑦ TRIG key : Used to make sampling once under the sampling hold state.  
In the numerical value input mode, the key "5" is effective.

- ⑧ NULL key : Used to set the NULL mode.  
In the numerical value input mode, the key "6" is effective.
- ⑨ COMPARE key : Used to set the COMPARE mode.  
In the numerical value input mode, the key "7" is effective.
- ⑩ DISCHARGE key : Used to bring the meter under the discharge state.  
In the numerical value input mode, the key is used to select the polarity "+" or "-".
- ⑪ CHARGE key : Used to bring the meter under the charge state.  
In the numerical value input mode, the key is used to input the decimal point ".".
- ⑫ MEASURE key : Used to bring the meter under the measure state.  
In the numerical value input mode, the key is used to cancel "CE".
- ⑬ CONTACT key : Used to execute contact checking.
- ⑭ PRGM/NORMAL key : Used to select the sequence program mode or normal measurement mode. When the sequence program mode is set, the LED on the key lights.  
In the numerical value input mode, the input key "8" is effective.
- ⑮ START key : Used to start program measurement.  
In the numerical value input mode, the key "9" is effective.
- ⑯ SET key : Used to set the generation voltage value.  
When pressing the key, other keys function as a numerical key.
- ⑰ OPERATE key : Used to select voltage generation on or off.
- ⑱ LOCAL key and GPIB status lamp
  - LOCAL key : Used to cancel the remote state. However, the remote state cannot be canceled when the mode is set to LOCAL LOCK OUT by the GPIB.
  - SRQ lamp : Lights when the meter sends the service request to the controller.
  - TLK lamp : Lights when the meter is under the talker state to send data.



- 
- LTN lamp : Lights when the meter is under the listener state to receive data.
- RMT lamp : Lights when the meter is under the remote state.
- ⑬ PARAMETER key : Used to set various parameters or execute functions. The function depends on each mode. See Table 2-2.
- ⑭ Fuse holder : Used for input protection.
- ⑮ V SOURCE terminal : Used as a generated voltage output terminal.
- ⑯ INPUT connector : Used as an input connector.
- ⑰ GND terminal : Used as an earth terminal. The terminal is connected to the meter frame.
- ⑱ GUARD terminal : Used to guard the input unit. The terminal is connected with the internal guard case.
- ⑳ LO terminal : Used as a terminal common to input and output.
- ㉑ HIGH VOLTAGE lamp : Lights when the generation voltage is set to 100V or more or the V SOURCE terminal voltage is approx. 100V or more.
-

Table 2 - 2 Parameter Key Functions

Mode Key	Normal measurement mode	Sequence program mode
CAL <input type="checkbox"/>	1. Zero cancel execution 2. Contact initial execution 3. Self-test execution	1. Selection of program No. 2. Setting of autostart value 3. Setting of charge time 4. Setting of discharge time 5. Setting of measure time
MEAS <input type="checkbox"/>	1. Setting of integration time 2. Setting of AD CAL 3. Setting of input amplifier gain 4. Setting of VS current limiter 5. Setting of auto-range up/down level 6. Setting of unit indication 7. Setting of trigger delay 8. Setting of autorenge delay	Same with the normal measurement mode
I/O <input type="checkbox"/>	1. Setting of D/A Out (R8340A only) 2. Setting of BCD Out (R8340A only) 3. Setting of GPIB address 4. Setting of power frequency	
COEF <input type="checkbox"/>	1. Setting of COMPARE-operation high level 2. Setting of COMPARE-operation low level 3. Setting of resistance value indication 4. Setting of electrodes for volume and surface resistivities 5. Setting of optional electrode coefficient 6. Setting of sample thickness for volume resistivity measurement	

Table 2 - 2 Parameter Key Functions (Cont'd)

Mode Key	Normal measurement mode	Sequence program mode
COEF <input type="checkbox"/>	7. Setting of contact level 8. Setting of buzzer ON/OFF 9. Setting of indication ON/OFF 10. Setting of contact initial integration time	} Same with the normal measurement mode
MEM <input type="checkbox"/>	1. Execution of data store 2. Execution of data recall	
CHANGE <input type="checkbox"/>	1. Changes the setting of each parameter.	
EXIT <input type="checkbox"/>	2. Catalogs the setting of each parameter and exits from the setting mode.	

## 2.3 Display Panel on Front Panel

Figure 2-3 shows the display panel on the front panel. The following is the description of each part on the display panel in order of numbers ㉗ through ㉛.

- ㉗ Sampling indicator  
: Lights when measurement sampling is executed.
- ㉘ VOL display  
: Lights when the mode is set to volume resistivity measurement.
- ㉙ SURF display  
: Lights when the mode is set to surface resistivity measurement.
- ㉚ LO, GO, and HI display  
: Displays the results of COMPARE operation.
- ㉛  $\Omega$  display : Displays the unit for resistance, volume resistivity, or surface resistivity.
- ㉜ LIMIT display  
: Displays when the current limiter for voltage generation is detected.
- ㉝ V display : Displays the unit of the generated voltage value.
- ㉞ Measured value indicator  
: Displays a measured value.
- ㉟ Unit indicator  
: Displays an exponent value in exponents or symbol unit.
- ㊱ A display : Displays the unit for current.
- ㊲ Generated voltage indicator  
: Displays the set generation voltage.
- ㊳ S display : Displays when a time parameter is set or data is stored.

## 2.4 Description of Rear Panel

Figure 2-4 shows the rear panel. The following is the description of each part on the panel in order of numbers ㉓ through ㉙. The R8340 has neither DA OUTPUT connector ㉕ nor BCD OUTPUT connector ㉖.

- ㉓ TRIGGER INPUT connector  
: Used as an input connector to control the start of measurement with external symbols.
- ㉔ COMPLETE OUTPUT connector  
: Used to output the signal to notify the end of measurement to the outside.
- ㉕ LID SIGNAL INPUT connector  
: Used to input the fixture lid operation signal.
- ㉖ EXT CAL switch  
: Used to calibrate the meter.

### CAUTION

Be sure to normally turn off the EXT CAL switch to operate the meter.

- ㉗ HANDLER INTERFACE connector  
: Used for input/output signals synchronizing with the external equipment including the auto handler and fixture.
- ㉘ GPIB connector  
: Used for external control with the GPIB.
- ㉙ DA OUTPUT connector (R8340A only)  
: Used to output a displayed measured value by D/A converting optional number of digits of the value.
- ㉚ BCD OUTPUT connector (R8340A only)  
: Used to output BCD codes of measurement results to the outside.
- ㉛ GND terminal  
: Used as an earth terminal. The terminal is connected to the meter chassis.
- ㉜ Fuse holder  
: Used as the fuse holder for power supply.
- ㉝ Power connector  
: Used to connect the power supply. Use the attached power cable A01402.

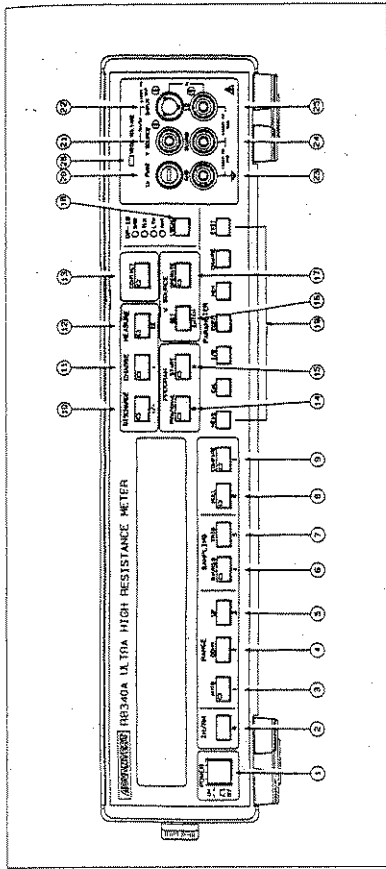

Figure 2 - 2 Description of Front Panel

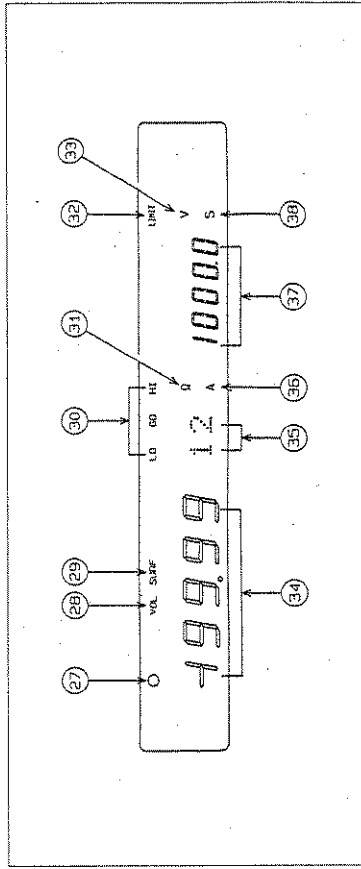

Figure 2 - 3 Description of Display Panel on Front Panel

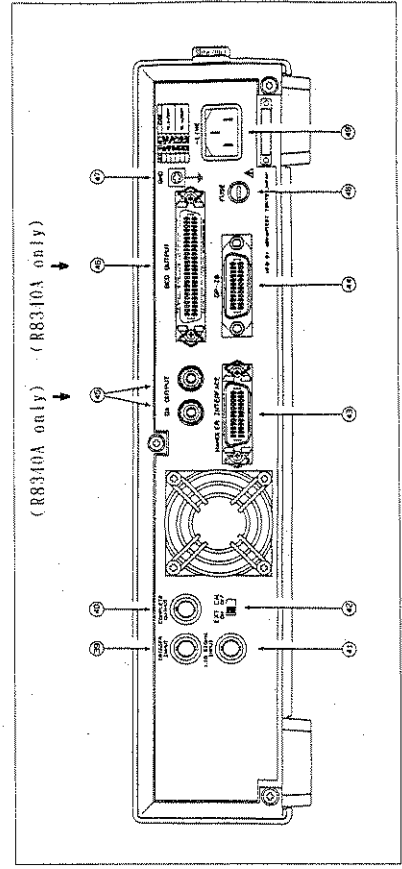

Figure 2 - 2 Description of Rear Panel

### 3. HOW TO OPERATE

This section describes the measurement preparation and basic operation method.

### 3.1 Measurement Preparation

#### 3.1.1 Power On

##### (1) Initial Operation

Operation ( ① and ② )

- ① Connect the attached power cable to the power connector on the rear panel of the meter.
- ② Turn on the power switch on the front panel.  
When the power switch is turned on, the following operation starts.

Turn on the power switch.

↓  
Self-test starts. All LEDs go out.

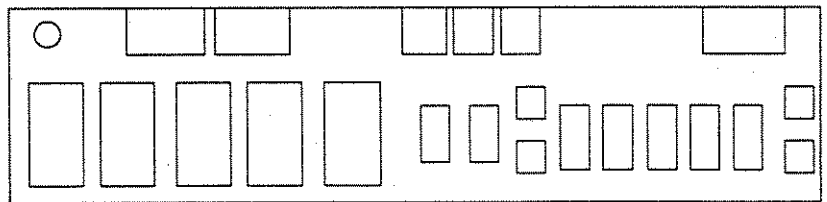

↓  
Self-test is being executed. All LEDs light.

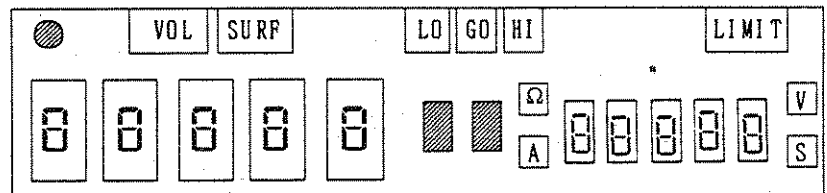

↓  
Self-test ends. All LEDs go out.

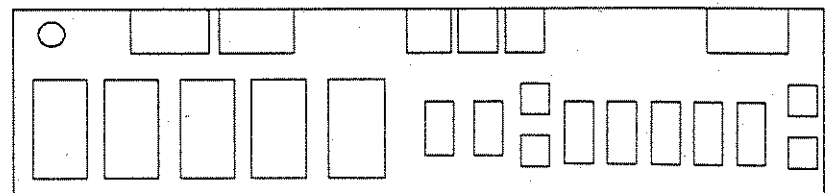

Ⓐ



Ⓐ

Software revision update is displayed.

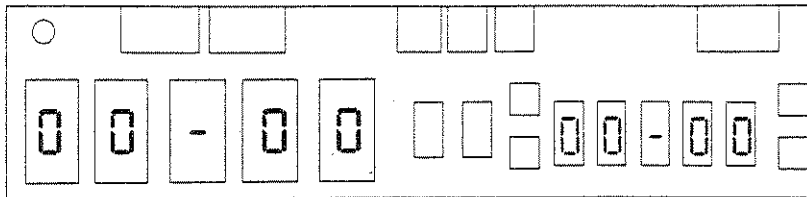

Logic  
software  
revision

Logic  
software  
update

Analog  
software  
revision

Analog  
software  
update

Normal operation

The range and parameter used when previously turning off the power switch are automatically set.

- (2) Be sure to set the power frequency to be used by operating the parameter key. For the setting method, see Item 4.5.4 "Power frequency".

Once the power frequency to be used is set, the power-frequency parameter is not canceled even if the power is turned off.

### 3.1.2 Various Messages

The meter displays various messages for abnormal input during operation. In this case, if the buzzer is set to ON, it sounds. The following is the description of various messages.

#### (1) Over-range Message

When the over-range message appears, raise the measurement range.

( Press the <sup>UP</sup>  key. )

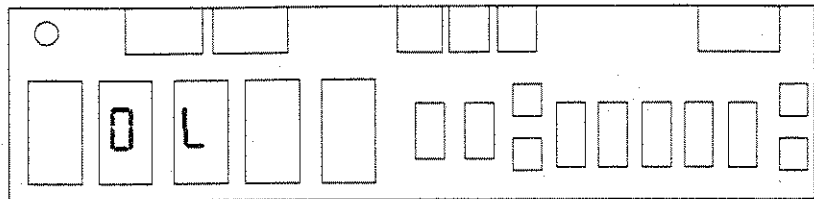

The above message appears in the following cases but the buzzer does not sound.

- The full scale for current measurement of the meter is "19999". However, when a value exceeding the full scale "19999" is input.
- For resistance measurement, operation is executed when the current value is kept between 3 and 19999. However, when the current measured value is equal to or less than "2" for the resistance measurement.
- When the input terminal is released for change of range or measurement of resistance, the message may appear.

#### (2) Overload Message

When the overload message appears, lower the measurement range.

( Press the <sup>DOWN</sup>  key. )

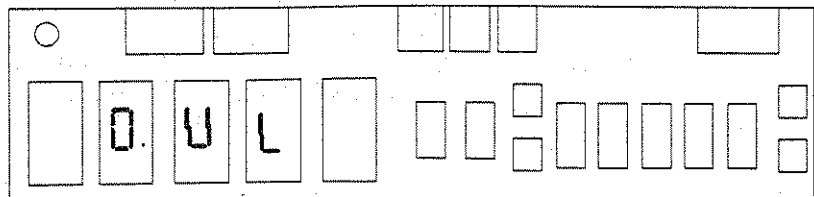

The above message appears in the following cases but the buzzer does not sound.

- When the current value exceed the range for resistance measurement, that is, when the current measured value exceeds "19999".

(3) Resistance Operation Error Message

When the resistance operation error message appears, set the output voltage.

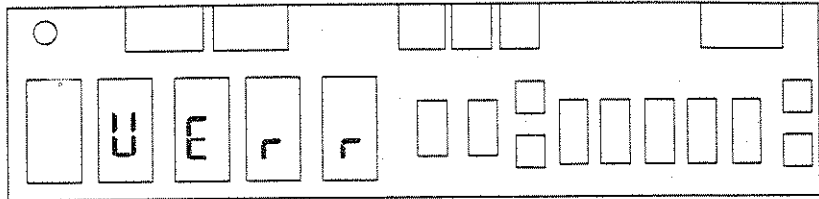

The above message appears in the following case but the buzzer does not sound.

- When the output voltage is set to 0V for measurement of resistance, volume resistivity, and surface resistivity.

(4) Fuse Open Detection Message

When the fuse open detection message appears, replace the input protection fuse.

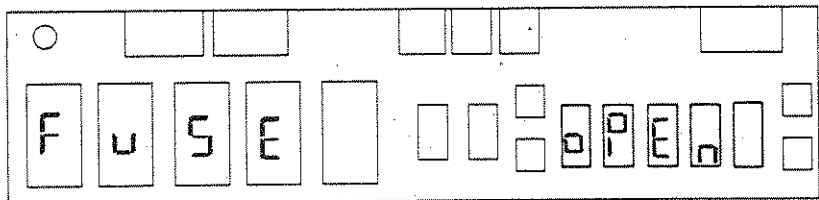

The above message appears in the following case and the high-pitched tone buzzer sounds.

- When overcurrent is input and the input protection fuse (1A) is gone.

(5) Limiter Message

When the limiter message appears, power is charged into or discharged from the sample. Start sample measurement after the message disappears.

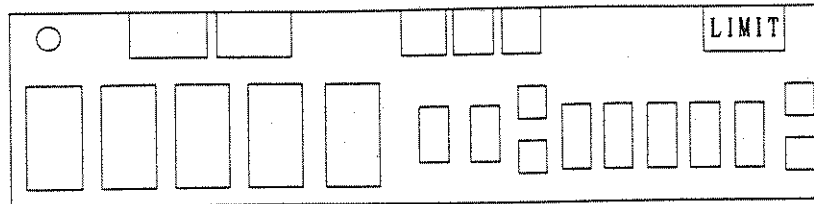

The above message appears in the following case but the buzzer does not sound.

- When the V SOURCE current limiter is detected.

(6) Overvoltage Detection Message

When the overvoltage detection message, remove the cable from V SOURCE terminal to eliminate overvoltage applied from the outside.

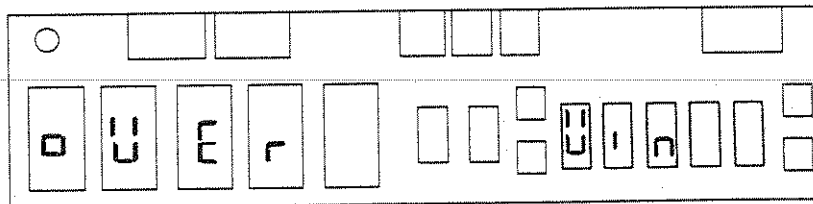

The above message appears in the following case and the high-pitched tone buzzer sounds and the V SOURCE becomes stand-by.

- When overvoltage is applied to the V SOURCE terminal (when negative voltage is applied or voltage of approx. 100V or more is applied for the setting between 0 and 100.00V).

(7) Overheat Detection Message

When the overheat detection message appears, immediately turn off the power switch.

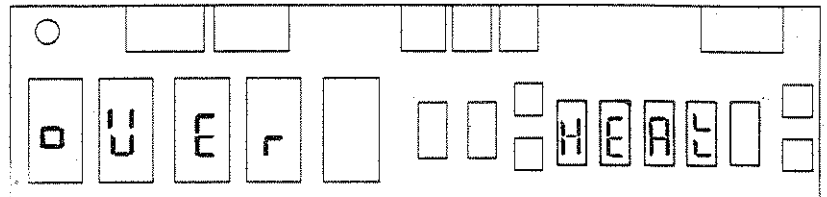

The above message appears in the following case and the high-pitched tone buzzer sounds and the V SOURCE becomes stand-by.

- When the internal circuit is overheated.

(8) Input Error

When a value impossible to set is input; the value flickers three times, the low-pitched tone buzzer sounds, and the state is ready for input again. In this case, input a correct value or press the  key to return the value to the previous one.

(9) If an error occurs, execute the following operation.

- ① When errors other than Err2 occur:

①-1 Turn off the power switch.

①-2 Immediately after turning on the power switch, press the  key. This operation is called "power on initialize". The "power on initialize" operation can also be made by the GPIB command "\*RST" or "Z". If an error still occurs after the "power on initialize" operation, the tester may be faulty. In this case, consult the nearest dealer or the sales and support offices.

- ② When Err2 occurs:

When Err2 occurs, make calibration according to the procedure in Item 9.2 "Calibration".

Table 3-1 shows various error messages and their descriptions.

Table 3 - 1 Error Messages

Error code	Error	Description
Err 1	Backup parameter damage	Contents of a parameter such as panel backup are rewritten.
Err 2	CAL DATA1 damage	Calibration primary data is rewritten.
Err 3	CAL DATA2 damage	Calibration secondary data is rewritten.
Err 4	Transfer error	Transfer error between internal CPUs
Err 5	Operation error	Operation error on measured values
Err IA	Input amplifier failure	Trouble of input amplifier or IV converter
Err AD	A/D failure	Trouble of AD converter
Err HV	100V amplifier failure	Trouble of amplifier for 10/100V range of V SOURCE output
Err KV	1000V amplifier failure	Trouble of amplifier for 1000V range of V SOURCE output
Err RA	RAM R/W error	Read/write trouble of logic RAM
Err EP	E <sup>2</sup> PROM R/W error	Read/write trouble of logic E <sup>2</sup> PROM
Err LR	LOGIC ROM error	Trouble of logic ROM
Err AR	ANALOG ROM error	Trouble of analog ROM

### 3.1.3. Table of Initialize Setting States

When the R8340 and R8340A press the AUTO key immediately after power-on, setting will be initialized as follows.

Setting item	Normal state (When EXT CAL on the rear panel is turned off)	Calibration state (When EXT CAL on the rear panel is turned on)
IM/RM	IM(DC measurement)	Same with normal state
RANGE	AUTO	
SAMPLING	RUN	
NULL	OFF	
COMPARE	OFF	
MODE	MEASURE	
CONTACT	OFF	
PRGM/NORM	NORMAL	
START	STOP	
VS	00.000V	
OPERATE	STANDBY	
Integration time	10PLC	
AD CAL	ON	
Input amplifier gain	× 10	
Current limiter	300mA	Same with normal state
Auto-range	UP 20000	
UP/DOWN level	DOWN 1799	
Unit indication	Symbol	
Trigger delay	0sec	
Autorange delay	0sec	
Zero cancel	OFF	
Contact initial	OFF	
Self-test	OFF	
DA OUT	OFF	
BCD OUT	OFF	
GPIB	Header ON, address- able address --	Header ON, address- able address 01
Power frequency	---	50Hz
UPPER	19.999mA	Same with normal state
LOWER	000.00pA	
Resistance measurement indication	Resistance value	
Setting of electrodes for volume and surface resistivities	50mm-dia main electrode	
Optional electrode coefficient	Same with the coefficient of 50mm-dia main electrode	
Sample thickness	1mm	
Contact checking level	× 1	

(Cont'd)

Setting item	Normal state (When EXT CAL on the rear panel is turned off)	Calibration state (When EXT CAL on the rear panel is turned on)
Buzzer	ON	} Same with normal state
Indication	ON	
Contact initial integration time	2ms	
Data store	OFF	
Data recall	OFF	
Stored data	Clear	
Program No.	0	
Charge time	60sec	
Discharge time	1sec	
Measurement time	0sec	
Automatic start value	001.00pA	



### 3.2 Basic Operation Method

The following describes the method for DC measurement (IM), voltage applying current measurement (VSIM), resistance measurement (VSRM), volume resistivity measurement, and surface resistivity measurement which are basic measurement functions.

Turn on the power switch to set the power frequency to be used before starting the following operation.

#### 3.2.1 How to Use Short bar of Earthed/Isolated Sample

**WARNING**

1. The R8340/8340A store the circuit to generate high voltage. Therefore, you are dangerous unless the frame is earthed.
2. Be sure to earth the frame using the three-pin connector of the attached power cable or the GND terminal on the front or rear panel.

(1) Connection of Isolated Sample

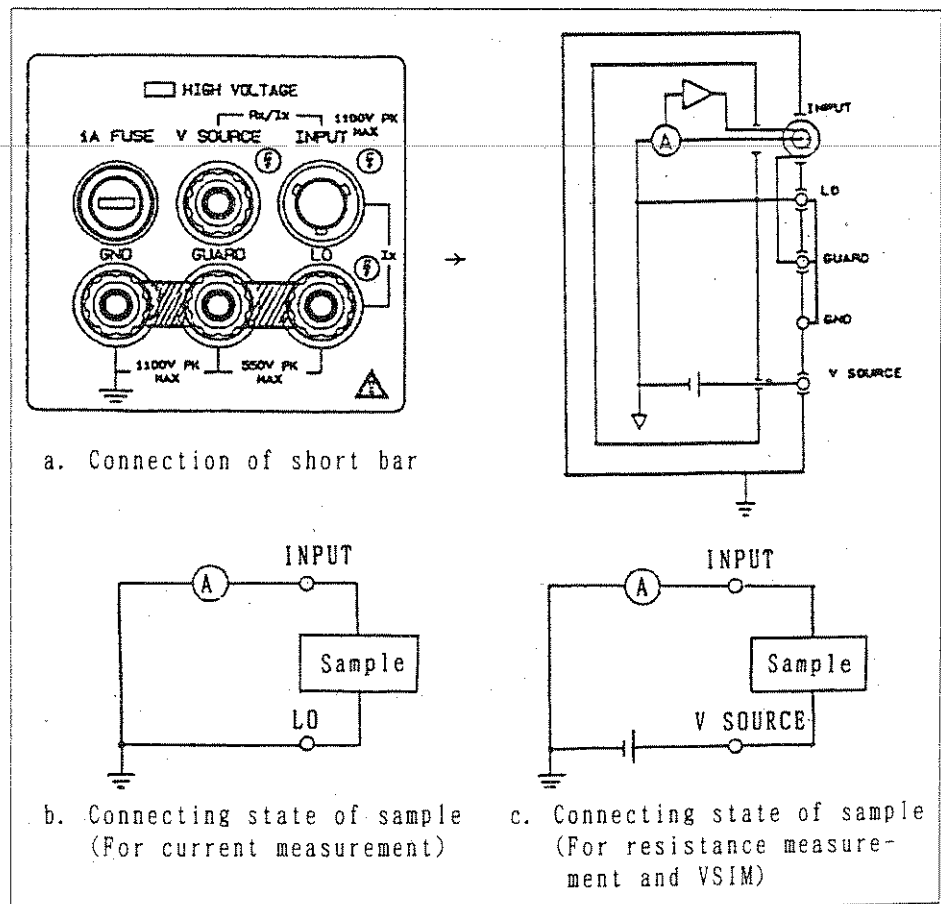

Figure 3 - 1 Connection of Isolated Sample

Operation(① through ③)

- ① Connect the short bar as shown in Figure 3-1a.
- ② For current measurement  
 Connect a sample between the INPUT and the LO terminals as shown in Figure 3-1b.
- ③ For resistance measurement and VSIM  
 Connect a sample between the INPUT and V SOURCE terminals as shown in Figure 3-1c.

(2) Connection of Earthed Sample (For current measurement)

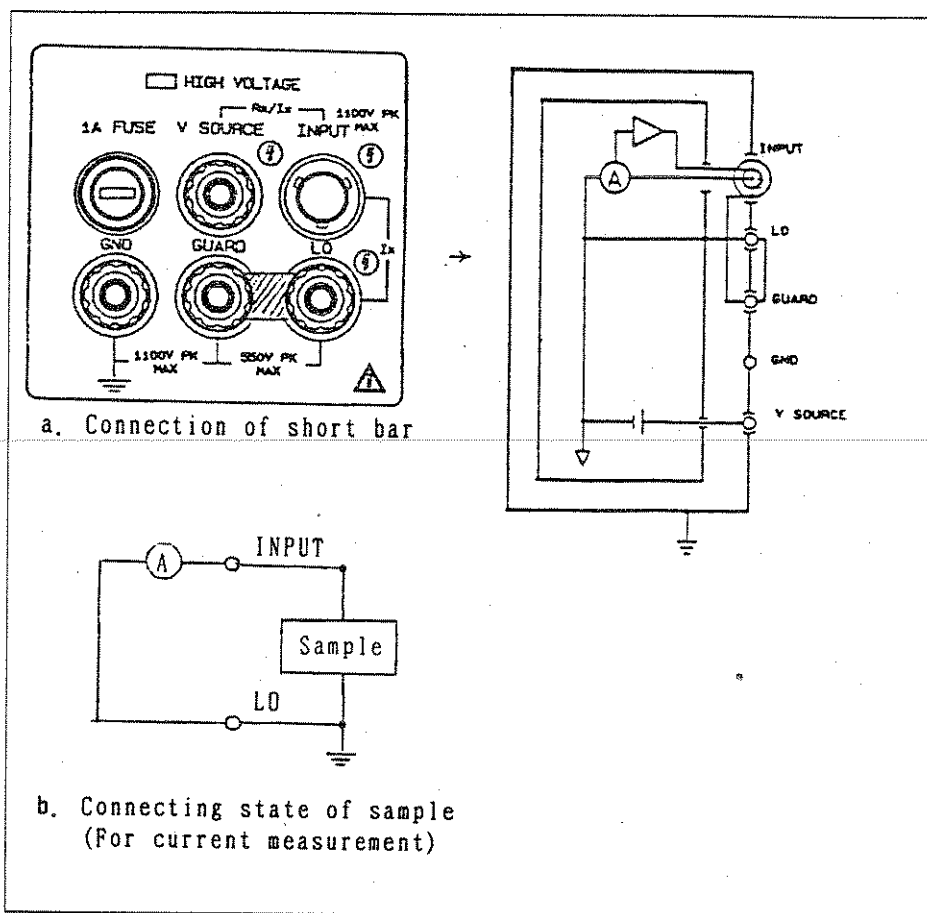

Figure 3 - 2 Connection of Earthed Sample for Current Measurement

Operation(① and ②)

- ① Connect the short bar as shown in Figure 3-2a.
- ② Connect a sample between the INPUT and LO terminals as shown in Figure 3-2b.

(3) Connection of Earthed Sample (For resistance measurement and VSIM)

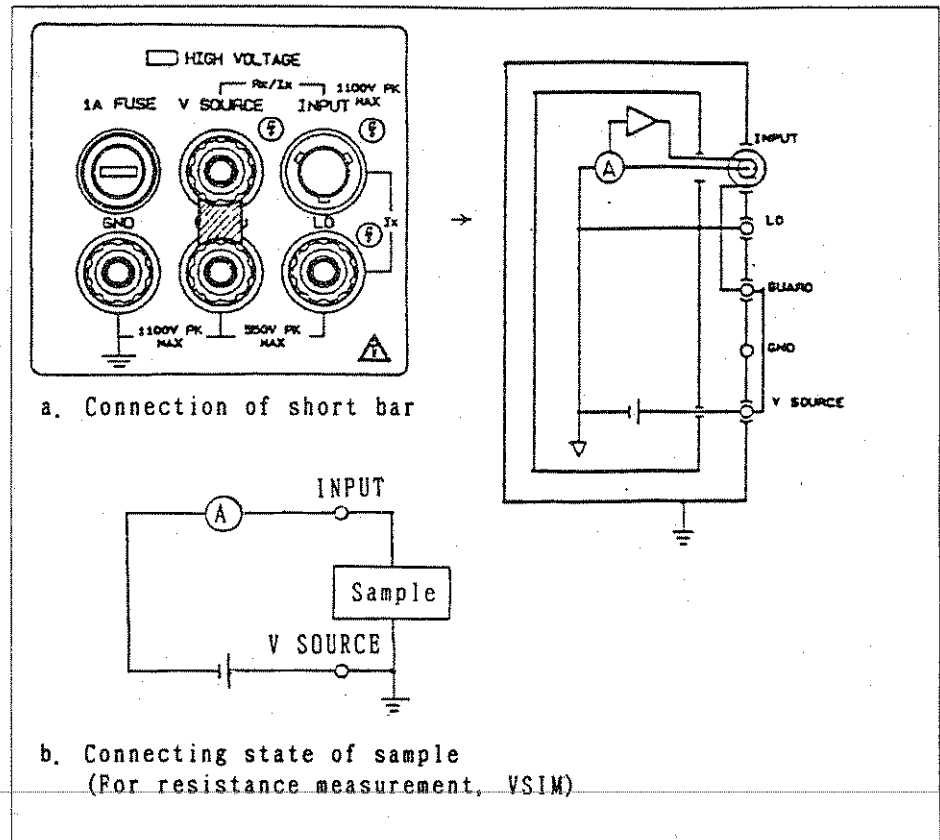

Figure 3 - 3 Connection of Earthed Sample for Resistance Measurement and VSIM

Operation(① and ②)

- ① Connect the short bar as shown in Figure 3-3a.
- ② Connect a sample between the INPUT and V SOURCE terminals as shown in Figure 3-3b.

CAUTION

1. When the V SOURCE and GUARD terminals are connected by the short bar, the voltage of -VS is applied to the core wire of the LO and INPUT terminals and the inside shield. This is the state when up to -1000V is applied.
2. You are dangerous if you connect an isolated sample according to the connection method in Figure 3-3.
3. Up to 550V can be applied to the R8340. To apply the voltage of more than 550V, use the R8340A.

(4) Connection for Coexistence of Isolated and Earthed Samples  
(For resistance measurement and VSIM)

When earthed and isolated samples are mixed or unknown for resistance measurement and VSIM, connect the sample as follows:

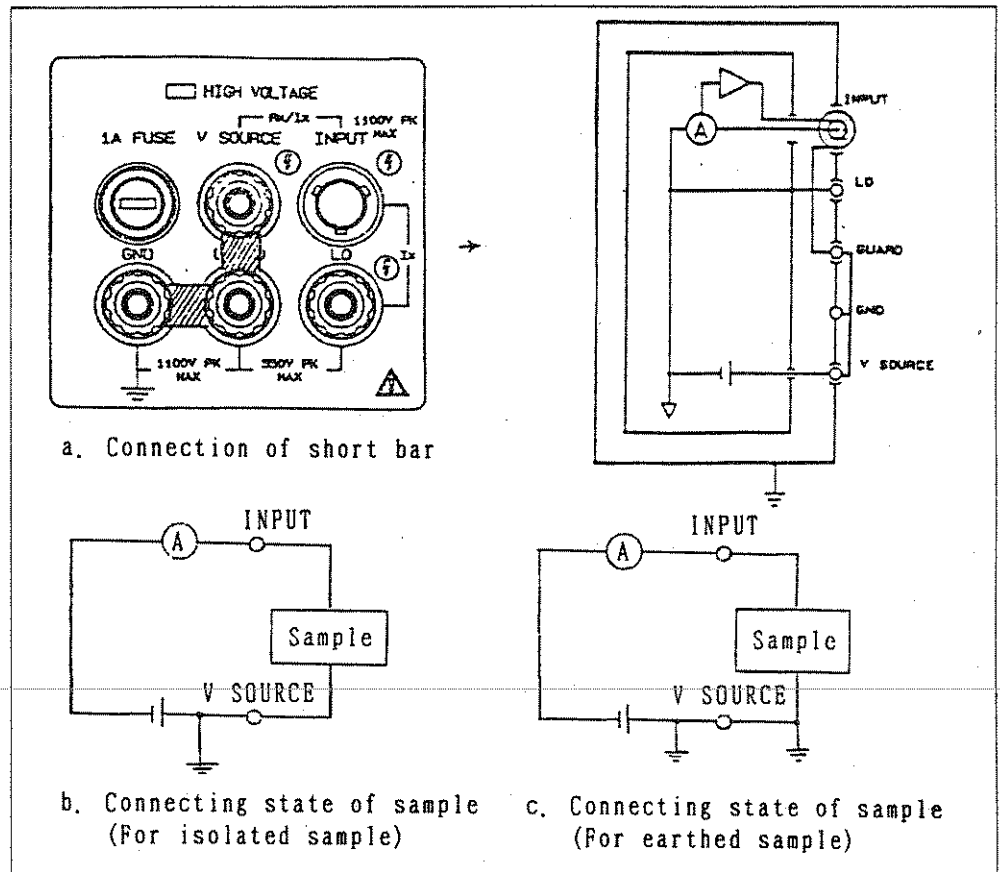

Figure 3 - 4 Connection for Coexistence of Isolated and Earthed Samples  
Operation(① and ②)

- ① Connect the short bar as shown in Figure 3-4a.
- ② Connect a sample between the INPUT and V SOURCE terminals as shown in Figure 3-4b.  
Connect an isolated sample as shown in Figure 3-4b and an earthed samples as shown in Figure 3-4c.

CAUTION

If you connect the short bar when the sample is isolated as shown in Figure 3-3, you are dangerous because voltage is applied to the external metal of the INPUT terminal and the GUARD terminal. Therefore, connect the sample as shown in Figure 3-4.

### 3.2.2 Discharge, Charge, and Measure

Figure 3-5 shows the basic flow of operation for DC measurement (IM), voltage applying current measurement (VSIM), resistance measurement (VSRM), volume resistivity measurement, and surface resistivity measurement of the meter.

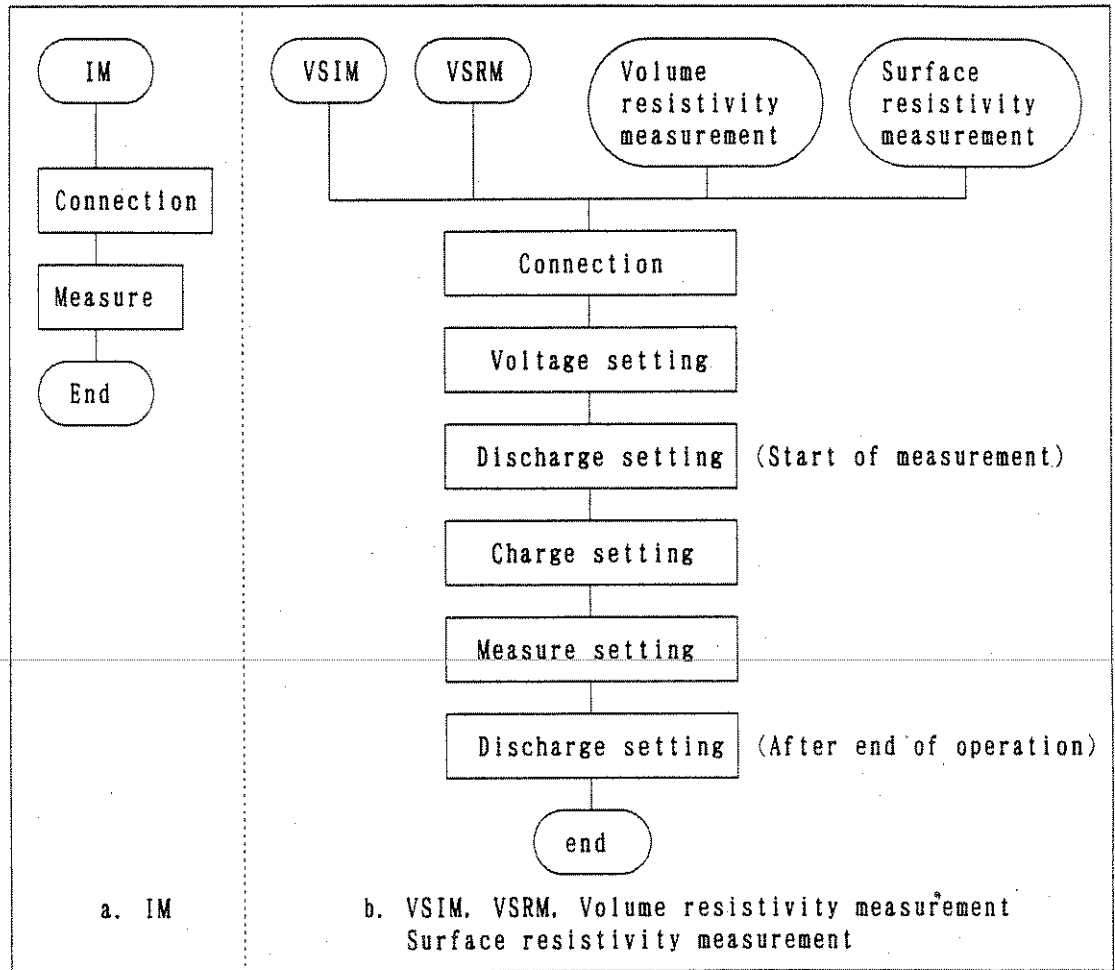

Figure 3 - 5 Basic Flow of Operation

The following describes discharge, charge, and measure shown in Figure 3-5. Also reference the equivalent circuit in Figure 3-6.

(1) Discharge

No voltage is applied to the sample. Because the  $V_s$  stores a current limiter, it constantly flows the sample discharge current.  
 Under the discharge state, no voltage is applied to the  $V_s$  and the  $S_1$  is turned on as shown in Figure 3-6.

(2) Charge

The voltage of the  $V_s$  is applied to the sample. The charge current is limited similarly to discharge in Item (1). Under the charge state, the  $V_s$  voltage is kept at the set value and the  $S_1$  is turned on as shown in Figure 3-6.

(3) Measure

The current flowing through the sample is measured under the state in which the voltage of the  $V_s$  is applied to the sample. Under the measure state, the  $V_s$  voltage is kept at the set value and the  $S_1$  is turned off.

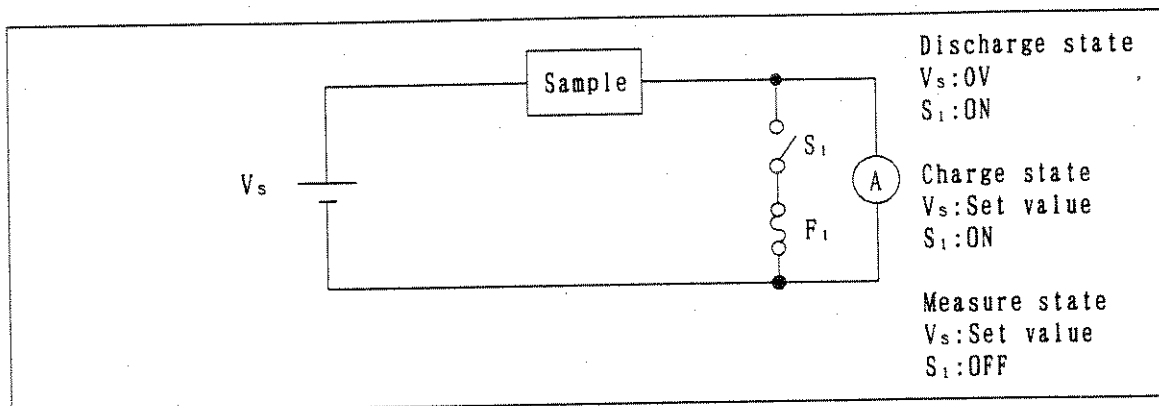

Figure 3 - 6 Equivalent Circuit Under Discharge, Charge, and Measure States

Note: The fuse in Figure 3-6 protects the  $F_1$  when overcurrent is applied from an external power supply under discharge or charge state.

Figure 3-7 shows the basic method to measure voltage applying current, resistance, volume resistivity, and surface resistivity.

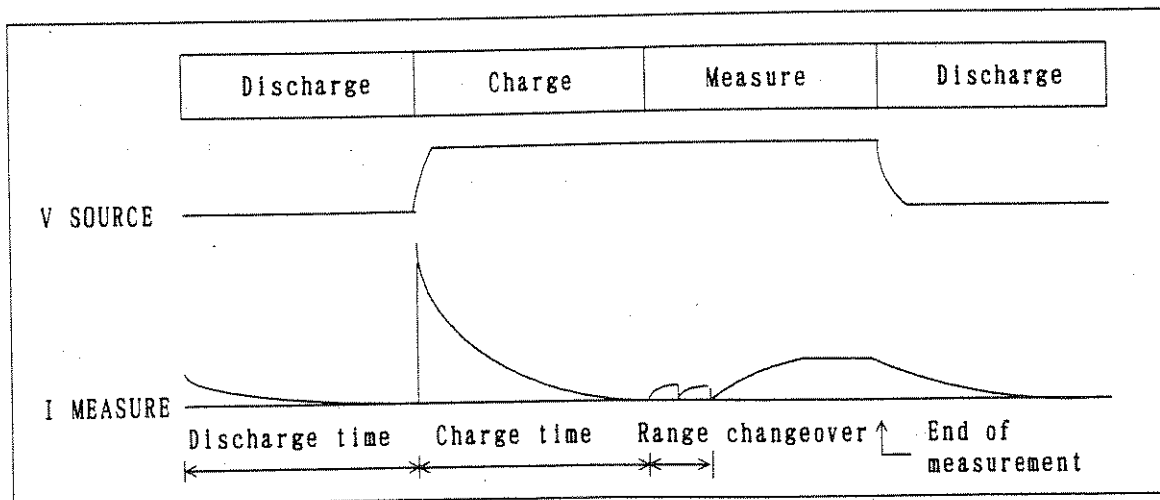

Figure 3 - 7 Basic Measurement

### 3.2.3 DC Measurement (IM)

The following describes the basic flow of operation for DC measurement shown in Figure 3-5a in detail.

Operation((1) through (3))

(1) Setting of Current Measured Value Indication

Set the <sup>IM/RM</sup>  
 key to the current measured value indication IM.

(2) Connection of Input/Output Cables

Follow the connection procedure in Item 3.2.1 Sub-item (1) or (2).

CAUTION

The V SOURCE terminal on the meter outputs up to 1000V. Therefore, connect the input/output cables and the sample to be measured under any one of the following states for safety.

- Power-off state
- Discharge state (The LED of the DISCHARGE key lights.)
- V SOURCE stand-by state (The LED on the OPERATE key goes out.)

(3) MEASURE Setting

- ① Check if the V SOURCE is stand-by (the LEDs of the OPERATE key go out).

If not, press the <sup>OPERATE</sup>  
 key.

- ② Press the <sup>MEASURE</sup>  
 key to set the measure state (the LED of the MEASURE key lights).

- ③ Read the measured value indication.

### 3.2.4 Voltage Applying Current Measurement (VSIM)

The following describes the basic flow of operation for voltage applying current measurement shown in Figure 3-5b in detail. Reference Figure 3-7 according to necessity.

Operation((1) through (7))

(1) Setting of Current Measured Value Indication

Set the <sup>IM/RM</sup>  
 key to the current measured value indication IM.

(2) Connection of Input/Output Cables

See the connection procedure in Item 3.2.1 Sub-items (1), (3), and (4).

CAUTION

The V SOURCE terminal on the meter outputs up to 1000V. Therefore, connect the input/output cables and the sample to be measured under any one of the following states for safety.

- Power-off state
- Discharge state (The LED of the DISCHARGE key lights.)
- V SOURCE stand-by state (The LED on the OPERATE key goes out.)

(3) Voltage Setting

① Setting of generated voltage value

①-1 Press the  key.

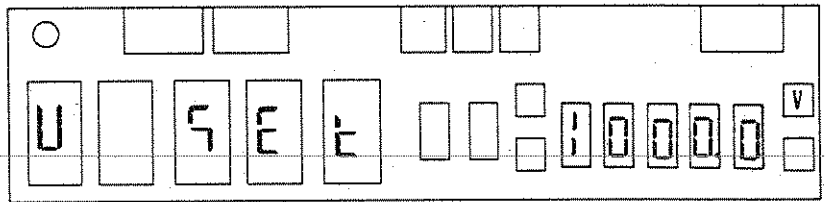

Present set voltage

①-2 Set the value to 123.4V.

Press the  key.

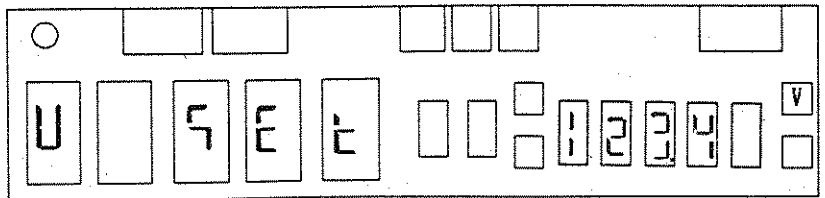



①-3 Press the  key.

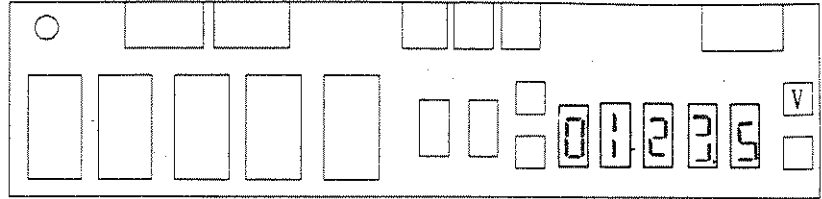

Newly as voltage

CAUTION

- Resolution for voltage setting  
 The resolution for voltage setting is 2.5 counts.  
 Therefore, the set value of the input final digit, is set as follows:

Input value		Set value
0,1	→	0
2,3	→	3
4,5,6	→	5
7,8	→	8
9	→	0

- Input error  
 The setting range is 0.0 to 1000.0V. If a value exceeding the range is set (when the ENTER key is pressed); an input error occurs, the input value flickers three times, and the state is ready for value input again.
- Value change  
 If inputting an incorrect value, press the  key and the preceding set value is displayed and a new value can be set.
- HIGH VOLTAGE LED  
 When the set value is 100.3V or more, the HIGH VOLTAGE LED lights.

② Output of set voltage

OPERATE

When the  key is pressed, the set voltage is output. The LED of the key lights during operation.

(4) Discharge Setting

**DISCHARGE**  
 When the  key is pressed, the discharge state is set, the V SOURCE is brought to 0V, input is shorted, and the electric charge in the sample is discharged.

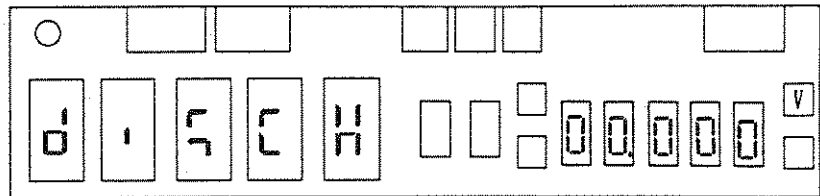

The above state can be canceled only by the **CHARGE**  and **MEASURE**  keys.

(5) Charge Setting

**CHARGE**  
 When the  key is pressed, the charge state is set, the set value of V SOURCE is output, input is shorted, and the sample to be measured is charged.

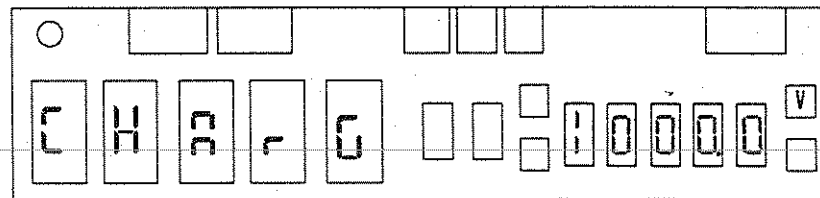

Set voltage value

The above state can be canceled only by the **DISCHARGE**  and **MEASURE**  keys. If the **OPERATE**  key is stand-by, no voltage is generated.

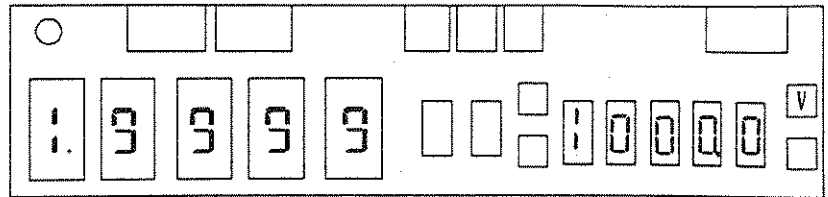

(6) Measure Setting

When the <sup>MEASURE</sup>  key is pressed, the measure state is set, the set value of V SOURCE is output, input is ready for measurement, and measurement is started.



Measurement state

Set voltage value

The above state can be canceled only by the <sup>DISCHARGE</sup>  and <sup>MEASURE</sup>  keys. If the <sup>OPERATE</sup>  key is stand-by, no voltage is generated.

(7) Discharge Setting

After measurement, press the <sup>DISCHARGE</sup>  key and the electric charge in the sample is discharged.

### 3.2.5 Resistance Measurement (VSRM)

The resistance of the meter is expressed as the value obtained by dividing the generated voltage by the measured current as shown below.

$$\text{Resistance value} = \text{Generated voltage} / \text{measured current}$$

The following describes the basic flow of operation for resistance measurement (VSRM) shown in Figure 3-5b in detail. Reference Figure 3-7 according to necessity.

Operation((1) through (7))

(1) Setting of Resistance Measured Value Indication

Set the  $\boxed{\text{IM/RM}}$  key to the resistance measured value indication RM.

(2) Connection of Input/Output Cables

For connection of input/output cables, see Item 3.2.1 Sub-items (1), (3), and (4).

(3) Voltage Setting

① Setting of generated voltage

①-1 Press the  $\boxed{\text{SET}}$  key.

Display panel state

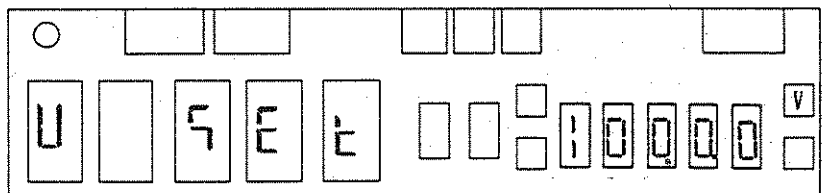

Present set voltage

①-2 Set the value to 123.4V.

Press the  $\boxed{\text{1}}\boxed{\text{2}}\boxed{\text{3}}\boxed{\text{.}}\boxed{\text{4}}$  keys.

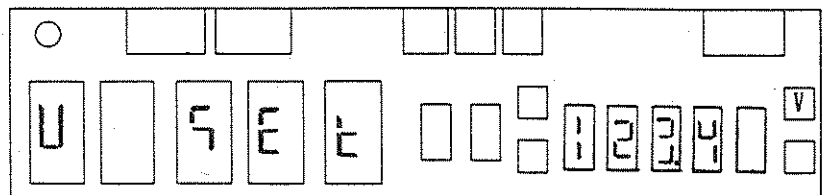

①-3. Press the  key.

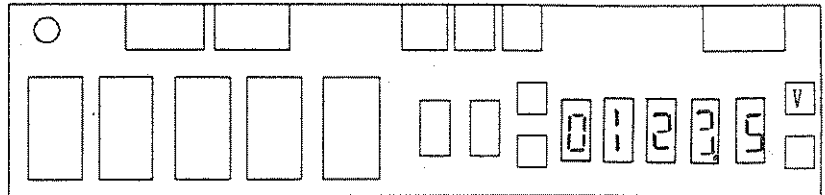

Newly set voltage

CAUTION

1. Resolution for voltage setting  
 The resolution for voltage setting is 2.5 counts.  
 Therefore, the set value of the input final digit is set as follows:
 

Input value	Set value
0, 1	→ 0
2, 3	→ 3
4, 5, 6	→ 5
7, 8	→ 8
9	→ 0
2. Input error  
 The setting range is 0.0 to 1000.0V. If a value exceeding the range is set (when the ENTER key is pressed); an input error occurs, the input value flickers three times, and the state is ready for value input again.
3. Value change  
 If inputting an incorrect value, press the  key and the preceding set value is displayed and a new value can be set.
4. HIGH VOLTAGE LED  
 When the set value is 100.3V or more, the HIGH VOLTAGE LED lights.

② Output of set voltage

When the  key is pressed, the set voltage is output. The LED of the key lights during operation.

(4) Discharge Setting

**DISCHARGE**  
 When the  key is pressed, the discharge state is set, the V SOURCE is brought to 0V, input is shorted, and the electric charge in the sample is discharged.

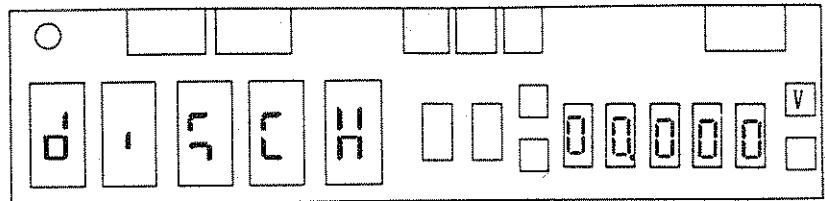

The above state can be canceled only by the  **CHARGE** and  **MEASURE** keys.

(5) Charge Setting

**CHARGE**  
 When the  key is pressed, the charge state is set, the set value of V SOURCE is output, input is shorted, and the sample to be measured is charged.

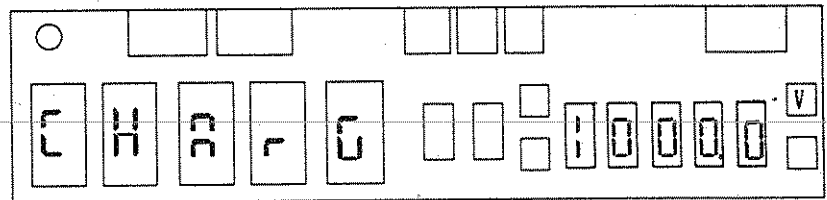

Set voltage value



The above state can be canceled only by the  **DISCHARGE** and  **MEASURE** keys. If the  **OPERATE** key is stand-by, no voltage is generated.

(6) Measure Setting

When the <sup>MEASURE</sup>  key is pressed, the measure state is set, the set value of V SOURCE is output, input is ready for measurement, and measurement is started.

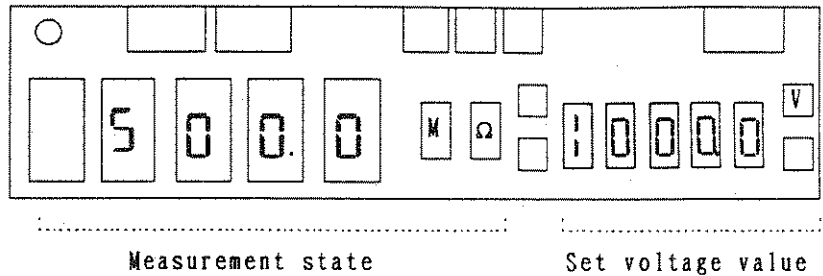
Display panel state



The above state can be canceled only by the <sup>DISCHARGE</sup>  and <sup>MEASURE</sup>  keys. If the <sup>OPERATE</sup>  key is stand-by, no voltage is generated.

(7) Discharge Setting

After measurement, press the <sup>DISCHARGE</sup>  key and the electric charge in the sample is discharged.

### 3.2.6 Measurement of Volume Resistivity and Surface Resistivity

#### (1) How to Obtain Volume and Surface Resistivities

Obtain the volume and surface resistivities with the measuring electrodes specified in JIS K-6911 and K-6723 shown in Figure 3-8 and 3-9 by measuring resistances and using the following formulas.

$$\text{Volume resistivity } \rho v = \frac{\pi d^2}{4t} \times Rv \quad \text{--- ①}$$

$$\text{Surface resistivity } \rho s = \frac{\pi (D+d)}{D-d} \times Rs \quad \text{--- ②}$$

- $\rho v$ : Volume resistivity [Ω cm]
- $\rho s$ : Surface resistivity [Ω]
- $Rv$ : Volume resistance [Ω] ← Measured value
- $Rs$ : Surface resistance [Ω] ← Measured value
- $\pi$ : Ratio of the circumference of a circle to its diameter = 3.14
- $t$ : Sample thickness [cm]
- $D$ : Inside diameter of guard electrode [cm]
- $d$ : Diameter of main electrode [cm]

The electrode dimensions are specified in JIS as shown in Table 3-2. When substituting these values for the above formulas ① and ②, the following formulas ③ through ⑥ are obtained. (The above-mentioned units is used for calculation.)

Table 3 - 2 Electrode Dimensions Specified in JIS

	JIS-K6911	JIS-K6723
Outside diameter of main electrode d-dia	50mm	70mm
Inside diameter of guard electrode D-dia	70mm	90mm

• For JIS-K6911 (Main-electrode outside diameter of 50mm-dia)

$$\text{Volume resistivity } \rho v = 19.63 \times \frac{Rv}{t} \quad [\Omega \text{ cm}] \quad \text{--- ③}$$

$$\text{Surface resistivity } \rho s = 18.84 \times Rs \quad [\Omega] \quad \text{--- ④}$$



- For JIS-K6723 (Main-electrode outside diameter of 70mm-dia)

$$\text{Volume resistivity } \rho v = 38.47 \times \frac{Rv}{t} \quad (\Omega \text{ cm}) \quad \text{--- ⑤}$$

$$\text{Surface resistivity } \rho s = 25.12 \times Rs \quad (\Omega) \quad \text{--- ⑥}$$

The volume and surface resistivities can be obtained by substituting measured values for the above formulas ③ through ⑥.

- (2) Volume Resistivity Measuring Functions and Surface Resistivity Measuring Functions of the Meter

The meter calculates the volume and surface resistivities with resistance measured values through internal operation using the formulas ③ through ⑥.

The measurement using the electrode in JIS-K6911 (main-electrode outside diameter of 50mm-dia) or JIS-K6723 (main-electrode outside diameter of 70mm-dia) is selected by setting parameters.

It is also possible to set the constant (electrode factor) in ③ and ④ formulas to an optional value. Set an optional value for the measurement using electrodes with any dimensions out of JIS.

For the volume resistivity measurement, it is needed to set the thickness of the sample to be measured. In these set values, unit is mm.

The following describes the basic flow of operation for volume and surface-resistivity measurement in Figure 3-5b in detail. Reference the basic measurement in Figure 3-7 according to necessity.

#### Operation((1) through (9))

- (1) For how to select volume resistivity measurement indication or surface resistivity measurement indication, see Item 4.4.3.
- (2) For how to set electrode to be used, see Items 4.4.4 and 4.4.5.
- (3) To measure volume resistivity, set the sample thickness by referencing Item 4.4.6.

(4) Connecting the instrument to test fixtures, refer to chapter 11.

- ① For volume resistivity measurement  
Connect the electrode as shown in Figure 3-8.
- ② For surface resistivity measurement  
Connect the electrode as shown in Figure 3-9.

When the TR42 and TR43C test fixtures are connected to the meter, volume or surface resistivity can be selected by connecting a short bar.

When the R12702A/B and R12704 test fixtures are connected to the meter, resistivity selection can be made with a switch.

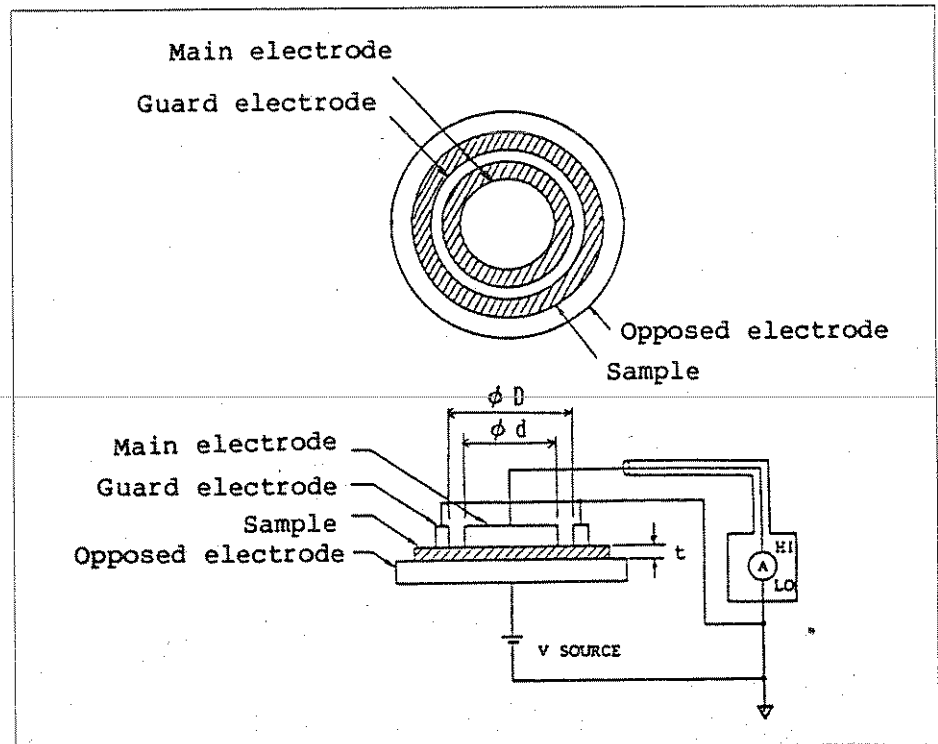

Figure 3 - 8 Electrode Connection (For volume resistivity measurement)

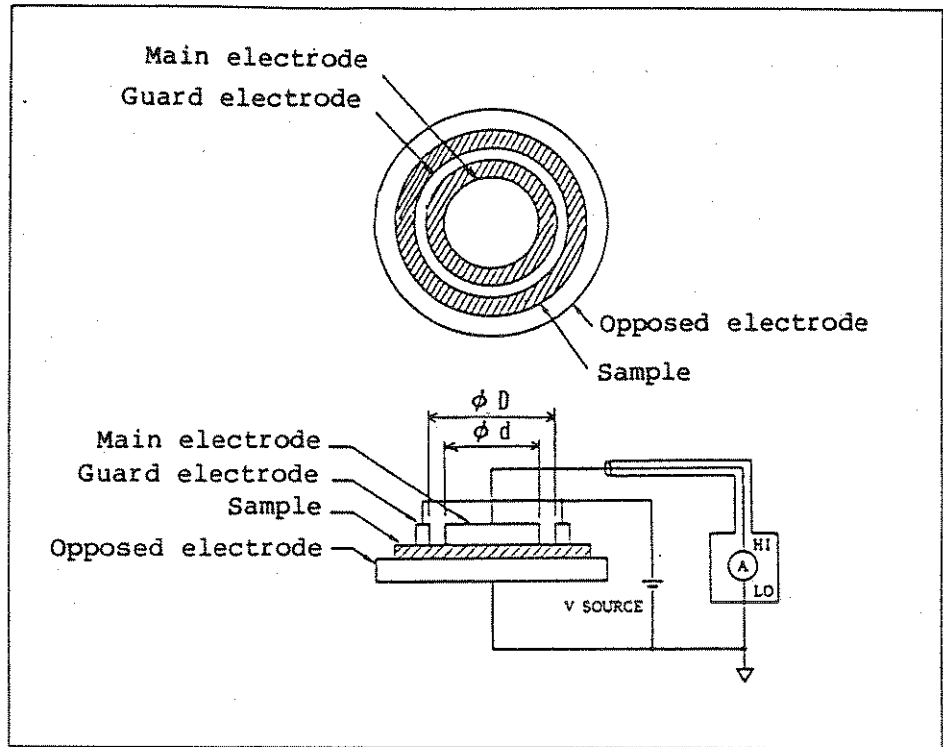

Figure 3 - 9 Electrode Connection (For surface resistivity measurement)

(5) Voltage Setting

① Setting of Generated Voltage Value

①-1 Press the  key.

Display panel state

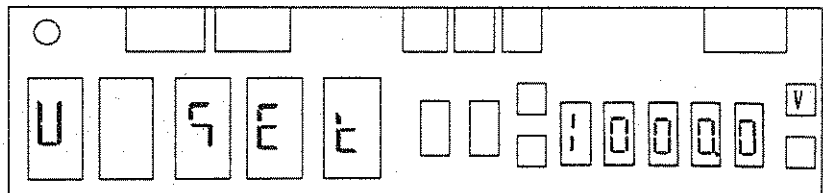

Present set voltage

①-2 Set the value to 123.4V.

Press the      keys.

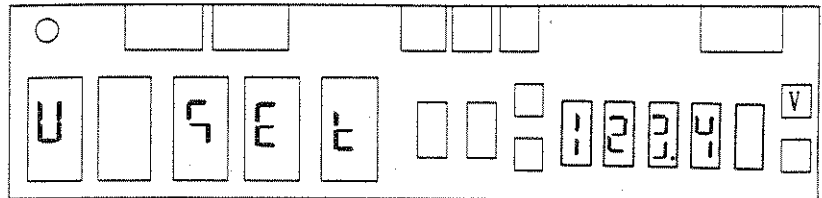

①-3 Press the  key.

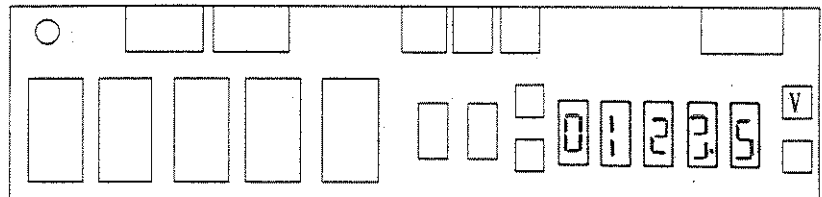

Newly set voltage

② Output of set voltage

When the  key is pressed, the set voltage is output. The LED of the key lights during operation.

#### CAUTION

##### 1. Resolution for voltage setting

The resolution for voltage setting is 2.5 counts.  
Therefore, the set value of the input final digit is set as follows:

Input value	Set value
0.1	→ 0
2.3	→ 3
4.5.6	→ 5
7.8	→ 8
9	→ 0

##### 2. Input error

The setting range is 0.0 to 1000.0V. If a value exceeding the range is set (when the ENTER key is pressed); an input error occurs, the input value flickers three times, and the state is ready for value input again.

CAUTION

(cont'd)

3. Value change  
If inputting an incorrect value, press the  key and the preceding set value is displayed and a new value can be set.

4. HIGH VOLTAGE LED  
When the set value is 100V or more, the HIGH VOLTAGE LED lights.



(6) Discharge Setting

DISCHARGE

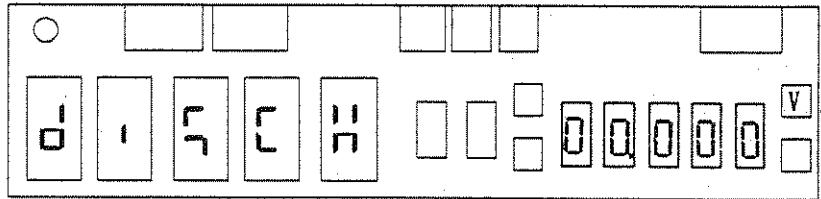
When the  key is pressed, the discharge state is set, the V SOURCE is brought to 0V, input is shorted, and the electric charge in the sample is discharged.



CHARGE      MEASURE

The above state can be canceled only by the  and  keys.

(7) Charge Setting

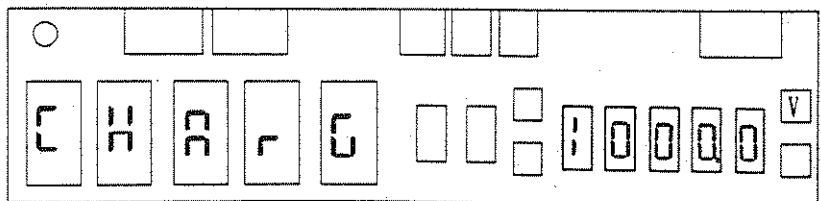

CHARGE

When the  key is pressed, the charge state is set, the set value of V SOURCE is output, input is shorted, and the sample to be measured is charged.



Set voltage value

DISCHARGE      MEASURE

The above state can be canceled only by the  and  keys. If the  key is stand-by, no voltage is generated.

(8) Measure Setting

When the <sup>MEASURE</sup>  key is pressed, the measure state is set, the set value of V SOURCE is output, input is ready for measurement, and measurement is started.

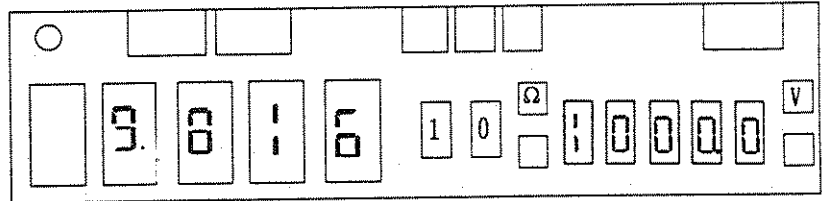

Measurement state

Set voltage value

The above state can be canceled only by the <sup>DISCHARGE</sup>  and <sup>MEASURE</sup>  keys. If the <sup>OPERATE</sup>  key is stand-by, no voltage is generated.

(9) Discharge Setting

After measurement, press the <sup>DISCHARGE</sup>  key and the electric charge in the sample is discharged.

### 3.3 Various Functions

#### 3.3.1 Null

This mode is effective for cancel of contact resistance, compensation of dark current, and cancel of background current.

This mode has the function to subtract the data displayed when pressing the NULL key from the next data and display the operation result as data. The operation includes polarity and range.

When assuming:

X(NULL): Measured data for NULL setting

X : Next measured data

R : NULL operation data

The NULL operation is expressed as  $R = X - X(\text{NULL})$ .

(Example1)

When assuming  $X(\text{NULL}) = -10.00\text{pA}$  (200pA range), and  
 $X = 1.0000\text{nA}$  (2-nA range), the following  
expression is obtained.  
 $R = 1.0100\text{nA}$  (2nA range)

(Example2)

When assuming  $X(\text{NULL}) = 1.0000\text{nA}$  (2nA range) and  
 $X = 0.0100\text{nA}$  (2nA range), the following  
expression is obtained.  
 $R = -0.9900\text{nA}$  (2nA range)

Operation(① and ②)

- ① When the  <sup>NULL</sup> key is pressed, the NULL mode is set and the LED on the key lights.
- ② When the  <sup>NULL</sup> key is pressed again, the NULL mode is canceled and the LED goes out.

#### CAUTION

1. When the NULL mode is set, the range is not lowered regardless of the auto and manual ranges.
2. When the  <sup>IM/RM</sup> key is pressed to change the volume resistivities, the surface resistivities and the auto range level, the NULL mode is canceled.
3. If the data when the NULL mode is set is out of the range, it is out of the range also in the NULL mode.

### 3.3.2 Compare

This mode has the function to compare the size of measured data with the upper level/lower level preset values and display the results. When the buzzer mode is set at ON, the buzzer sounds at the end of comparison. The following table shows the relationship between the operation results (comparison results) and indication.



Table 3 - 3 COMPARE Operation Results and Indication

Operation results	Indication	Buzzer
$X > Y$	HI	High-pitched tone
$Z \leq X \leq Y$	GO	No sound
$X < Z$	LO	Low-pitched tone

X: Measured data  
 Y: UPPER level set value  
 Z: LOWER level set value

The upper level/lower level set values can be set to the current measurement, resistance measurement, volume resistivity measurement, and surface resistivity measurement respectively, including polarity, range, decimal point, and exponential data. For how to set upper and lower levels, see Items 4.4.1 "Upper level" and 4.4.2 "Lower level".

#### Operation(① and ②)

- ① When the  key is pressed, the COMPARE mode is set and the LED on the key lights.
- ② When the  key is pressed again, the COMPARE mode is canceled and the LED goes out.



### 3.3.3 Integration Time

The input signal integration time of the A/D converter can be selected among the following seven types: 2ms, 1PLC, 5PLC, 10PLC, 10PLC × 4, 10PLC × 8, and 10PLC × 16. In this case, "PLC" stands for "Power Line Cycle" which means one cycle of AC power supply. The time of 1PLC equals 20ms for 50Hz and approx. 16.667ms for 60Hz. The time of "10PLC × 4" to "10PLC × 16" is the value obtained by averaging the data for 10PLC integration time 4 to 16 times respectively. If the integration time is increased by input noises when data variation is large, data with a small variation can be obtained.

For the integration time of 1PLC to 10PLC × 16, NMR of 60dB or more is obtained and the measured data is 4.5 digits. For the integration time of 2ms, NMR becomes 0dB and the measured data is 3.5 digits.

When the integration time is changed between 2ms and 10PLC, the AD CAL function operates and calibration measurement for 2 samples is executed.

For how to set integration time, see Item 4.2.1 "Integral time".

### 3.3.4 AD CAL

When the AD CAL function is set to ON, the A/D converter calibration is executed every approx. 10 sec.

This cycle is kept independently of integration time and RUN/HOLD. Because calibration cancels the offset drift of A/D converter.

Set this switch to ON when the measurement conditions change or when the meter has been used in the AD CAL OFF setting for a long time.

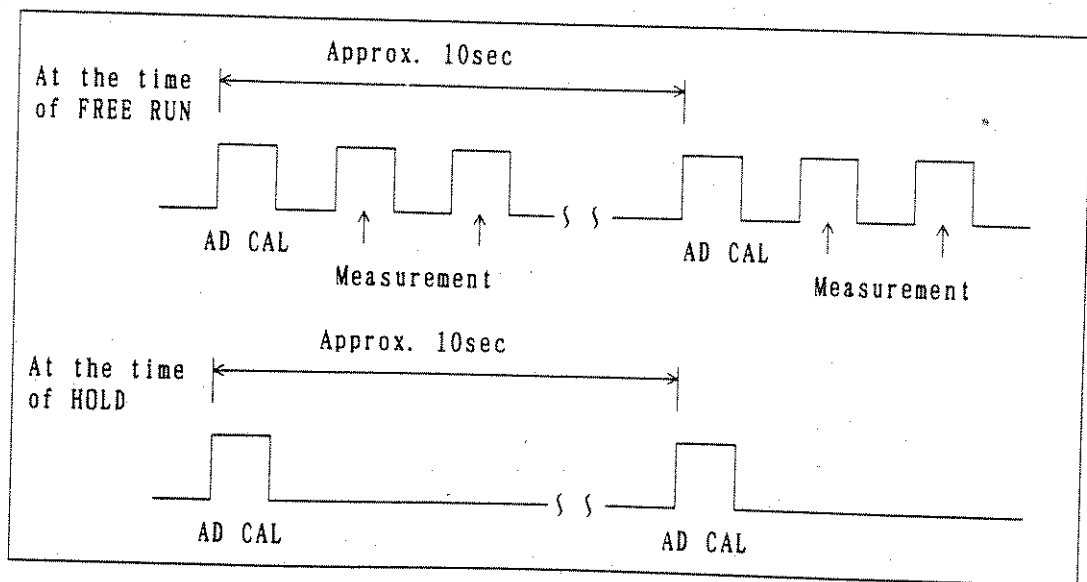

Figure 3 - 10 AD CAL Timing

When measurement is externally started during execution of the AD CAL function at the time of HOLD, it starts after the AD CAL function being executed finishes.

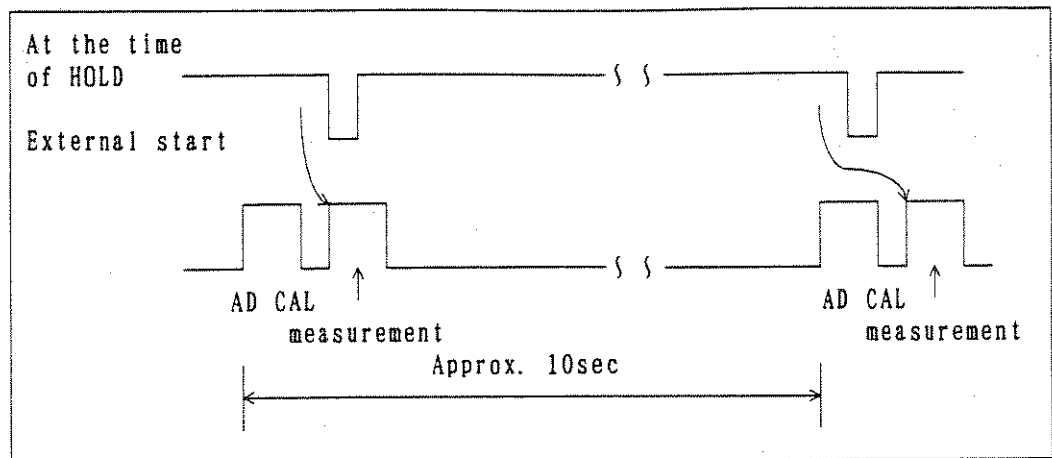

Figure 3 - 11 Timing When Measurement Starts During Execution of AD CAL Function

For how to set AD CAL function to ON or OFF, see Item 4.4.2 "AD CAL".

### 3.3.5 Input Amplifier Gain

The speed of measurement for leak current and insulation resistance of high-resistance samples, especially capacitors, is determined by the capacity  $C_x$  of the sample and the input resistance of the measuring instrument. Figure 3-12 shows the equivalent circuit.

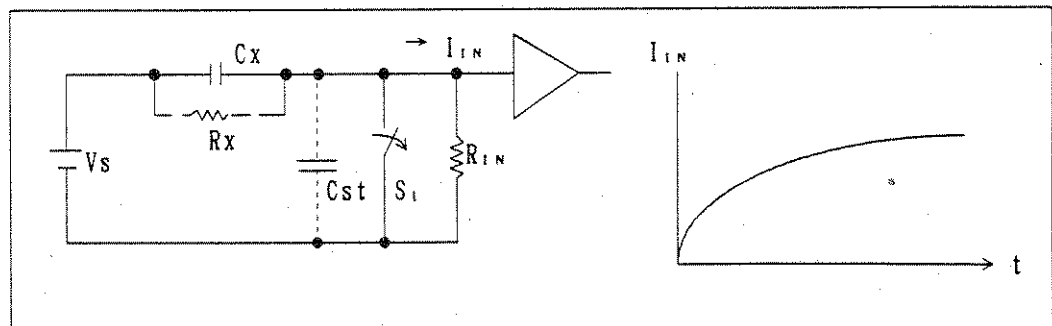

Figure 3 - 12 Equivalent Circuit for Measurement of Capacitor Leak Current

Figure 3-12 shows the response when  $S_1$  is set to ON in the charge state and then the measure state starts by turning  $S_1$  off after completion of charge.

For micro-current measurement,  $R_{IN}$  becomes a large value and its response takes a long time. When  $R_{IN}$  is set to  $1 \times 10^{10} \Omega$  in 100pA measurement, for example, the time of approx.  $5 \times 10^4$  sec is required according to the then constant if " $C_x$ " equals 1 $\mu$ F.

Even if the sample has a pure resistance, the response is delayed because of the cable capacitance "C<sub>x</sub>". For a coaxial cable, "C<sub>x</sub>" is generally equal to approx. 100pF/m. Therefore, in the above case, the time of approx. 5sec is required even for a pure resistance.

General electrometers use the feedback-system input circuit to decrease input resistance and improve response. Figure 3-13 shows the feedback-system equivalent circuit.

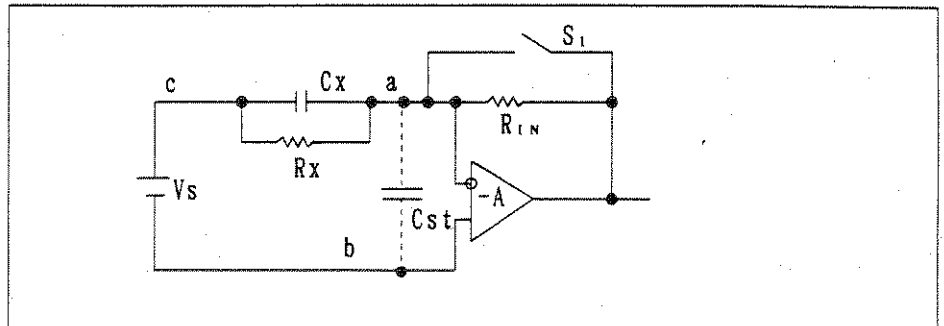





Figure 3 - 13 Feedback-system Equivalent Circuit

The feedback system greatly decreases the input resistance up to  $R_{IN}/A$ . In addition, because the potential difference between the points "a" and "b" is zero, there is no influence of C<sub>x</sub>. Therefore, response is much faster than that in Figure 3-12. However, because the AC noise at the points "a" and "c" is multiplied by "A", it is needed to completely shield the point "a" or minimize the V<sub>s</sub> noise. Especially for a large "C<sub>x</sub>" as in capacitor measurement, the noise between "c" and "a" is directly multiplied by "A" and even a very low noise becomes an issue.

Because the gain "A" in Figure 3-13 can be externally changed for the R8340 and R8340A, the input resistance can be selected according to the system noise condition and necessary measurement speed. For A = 1 in Figure 3-13, the equivalent circuit functions as the circuit same as that in Figure 3-12, which is strong in noises. When "A" is increased, the input resistance decreases and response quickens. The value of "A" can be selected among four cases of x 1, x 10, x 100, and x 10000 or more. To perform quick-response high-accuracy measurement, it is better to make "A" larger. However, the noise of the measurement system and V<sub>s</sub> must be decreased.

The initial set value is set to "x 10" by considering noise and response. For how to set input amplifier gain, see Item 4.2.3 "Input amplifier gain".

Input amplifier gain	X1	X10	X100	X10000
Response	Slow			Fast
Input resistance deviations	Large			Small
Noise resistance	Good			Bad

CAUTION

Error due to input resistance

In Figure 3-12, the error is produced because the voltage to be applied to the sample varies due to the voltage drop " $V_{IN} = R_{IN} \times I_{IN}$ " according to the input resistance. When the input amplifier gain is set to "x 1", the input voltage drop reaches up to 3.6V for full scale. Therefore, the  $V_s$  should be set to a value much larger than the above value. Table 3-4 shows the input resistance value when varying the input amplifier gain and the input voltage drop for full scale. Apply the voltage much larger than the above to a sample.

Table 3 - 4 Input Resistance and Input Voltage Drop for Full Scale

Input amplifier gain	× 1		× 10		× 100		× 10000	
	Input resistance	F. S voltage drop	Input resistance	F. S voltage drop	Input resistance	F. S voltage drop	Input resistance	F. S voltage drop
Current range								
200pA	10GΩ	2V	1GΩ	200mV	100MΩ	20mV	10KΩ or more	500μV
2nA	1GΩ	2V	100MΩ	200mV	10MΩ	20mV	1KΩ or more	500μV
20nA	100MΩ	2V	10MΩ	200mV	1MΩ	20mV	100Ω or more	500μV
200nA	10MΩ	2V	1MΩ	200mV	100kΩ	20mV	11Ω or more	500μV
2μA	1MΩ	2V	100kΩ	200mV	10kΩ	20mV	2Ω or more	500μV
20μA	100kΩ	2V	10kΩ	200mV	1kΩ	20mV	1Ω or more	500μV
200μA	10kΩ	2V	1kΩ	200mV	100Ω	20mV	1Ω or more	700μV
2mA	1.1kΩ	2.2V	110Ω	220mV	11Ω	22mV	1Ω or more	2.5mV
20mA	180Ω	3.6V	18Ω	360mV	3Ω	60mV	1Ω or more	20mV

### 3.3.6 Current Limiter (Current Compliance)

Table 3-5 shows the V SOURCE current limiter according to the set voltage and current compliance setting.

Table 3 - 5 Output Voltage and Current Limiter

Output Voltage	Current Compliance Setting		
	300mA	100mA	10mA
0.000V to 30.00V	± 300mA	± 100mA	± 10mA
30.03V to 100.00	± 100mA	± 100mA	± 10mA
100.3V to 1000.0	± 10mA	± 10mA	± 10mA

The V SOURCE realizes source and sink of current, which is convenient for charge and discharge like capacitor leak current measurement.

In addition, because the current limit value (compliance) can be selected, the sample limited in rush current such as a chemical capacitor can safely be charged and or discharged. In this case, an advantage lies in the fact that the charge/discharge speed increases compared with the existing speed of charge and discharge through resistance.

For example, the following shows the cases in which a 22μF 100mAMAX capacitor is charged up to 100V, 99% by passing through resistance and using compliance.

- ① When passing through resistance

$$t = 4.6\tau = 4.6CR = 4.6 \times 22\mu \times \frac{100V}{100mA} = 100ms$$

- ② When using compliance

$$t = CV/I = (22\mu \times 99V)/100mA = 22ms$$

From the above, it is found that the time can be saved when using compliance.

The discharge speed also increases.

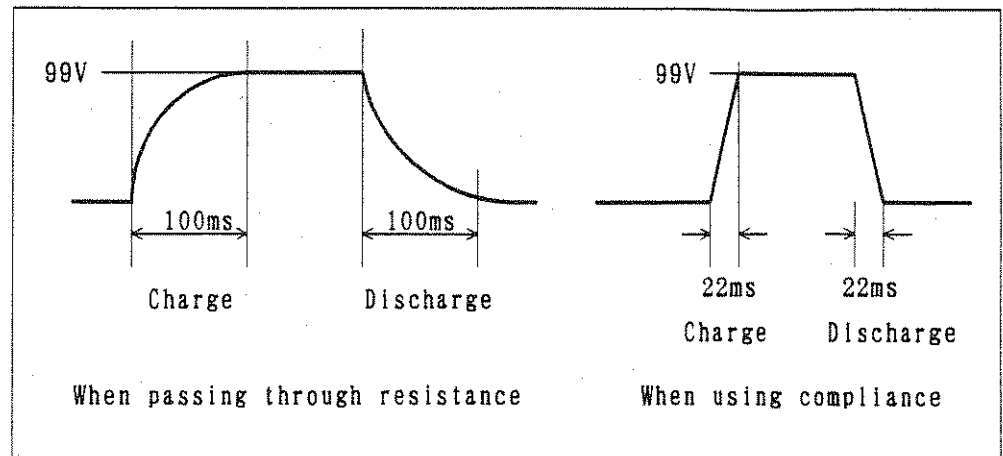

Figure 3 - 14 Charge and Discharge Speed

For how to set current limiter, see Item 4.2.4 "Current limiter" (Current compliance).

CAUTION

The current compliance value is automatically selected according to the output voltage of V SOURCE as shown in Table 3-5. When the current limiter is set to 300mA, for example, the compliance current is kept at 300mA for the voltage between 0 and 30.00V. However, the current automatically changes to 100mA for the voltage between 30.03 and 100.00V and to 10mA for the voltage between 100.3 and 1000.0V internally.

3.3.7 Auto Range Up/Down Level

The auto range is used to automatically go to an adjacent range to measure its value when the measure value in a range is too small or too large. (If a measured value is outside the range, measurement moves on to the next range. Measured values are not displayed during range switching.)

The "count value" is used to make this assessment. The count value is an integer made by eliminating the decimal point and the exponent from the display values.

Example) Displayed value :  $1.3142 \times 10^{-8}$       Count value : 13142

The auto range up/down level selects one of the three levels used to assess a value for a given range to handle.

Table 3 - 6 Setting Range and Count Values

Setting level	20000 (default)	2000	200	Remarks
Range up count value	20000 or more	2000 or more	200 or more	Not displayed
Count value that can be processed by the set range	19999 to 1800	1999 to 180	199 to 18	
Range down count value	1799 or less	179 or less	17 or less	Not displayed

Note : This assessment is based on the measured current value even in resistance display mode. Thus the above values are not applicable during the resistance indication (Since the resistance value is calculated and displayed by dividing the applied voltage with the current.)

Depending on which level is set, the range where the measurement is made may differ even when the measured current is the same during an auto range measurement. (See table below.)  
 When the level is lowered, the number of digits used to express the measurement is reduced while the input resistance is also reduced as the next higher range is used.

Table 3-7 Status Fluctuations Due to Level Selection While Measuring 13.142nA (when the input resistance is GAINXI)

Level setting	Displayed measurement	Measurement range	Count value	Input resistance
20000	13.142nA	20nA	13142	100MΩ
2000	13.14nA	200nA	1314	10MΩ
200	13.1nA	2 μA	131	1MΩ

As described in Item 3.3.5 "Input amplifier gain", the measurement speed is determined by the capacitance and input resistance of the sample to be measured. Therefore, the speed increases as the input resistance decreases.

When attempting to obtain the same number of measurement digits by decreasing the input resistance, the input amplifier gain increases to be weak in noises. Therefore, the function is effective to increase the measurement speed though large number of measurement digits is not needed.



For auto range, it takes time for ranging because of each sense resistance and sample capacitance if the range is too wide. In this case, the speed can be increased through ranging with a small sense resistance by decreasing the ranging level. For example, when measurement current changes from 10nA to 100pA in the auto range:

- ① For auto range up/down level of 20000  
 Because the measured value changes from 10.000nA to 100.00pA, the input resistance changes from 100MΩ to 10G Ω.
- ② For auto range up/down level of 2000  
 Because the measured value changes from 10.00nA to 100.0pA, the input resistance changes from 10MΩ to 1GΩ.

As above mentioned, the response is accelerated up to 10 times by making measurement with the 1/10 input resistance. For how to set auto range up/down level, see Item 4.2.5 "Auto range up/down level".

### 3.3.8 Contact Checking

Make sure that the sample is properly connected to the terminals when measuring the insulation resistance of capacitive samples (capacitors or the like). This can easily be done by performing a contact check.

The contact checking function judges the contact state of a sample by measuring the sample capacitance as shown in Fig. 3-15.

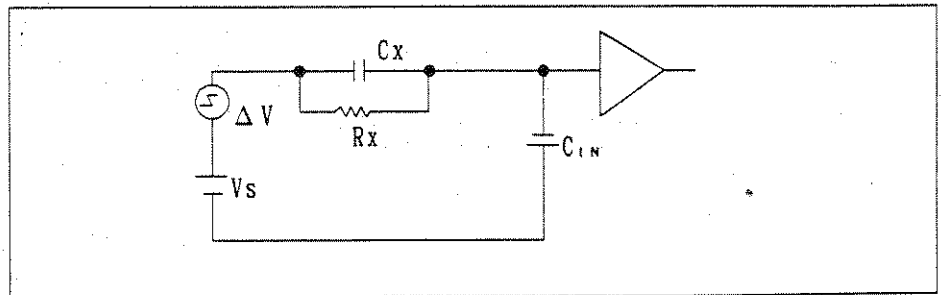

Figure 3 - 15 Contact Checking

$C_{IN}$  is a standard built-in capacitor. Step voltage  $\Delta V$  is applied to the V SOURCE output. The  $C_x$  value is derived from the difference between the voltages at both terminals of  $C_{IN}$  before and after the voltage is applied. The  $C_x$  value is evaluated by comparing it with the value measured at "contact initialization". The level to be compared is the  $C_{INI}$  value measured at initialization multiplied by coefficient  $n$  set for contact level.

Connect a standard capacitor and perform contact initialization. Although a comparison is made with this value during the contact check, the capacity of the measurement cables and the jigs may cause errors. For this reason, a contact initial offset measurement should be made first.

The contact check is successful if  $C_x \geq n \times (C_{INI} - C_{IO}) + C_{IO}$ .  
The contact check failed if  $C_x < n \times (C_{INI} - C_{IO}) + C_{IO}$ .

Here,  $C_x$  : Value measured at the time of a contact check  
 $C_{INI}$  : Value measured at the time of a contact initialization  
 $C_{IO}$  : Value measured at the time of a contact initialization offset  
 $n$  : Contact level

Perform the contact check as described below.

- ① Set the integral time of contact initialization and the contact level
- ② Specify that V SOURCE is to be used as the voltage source.
- ③ Connect a jig only and set it to charge status.
- ④ Set the instrument to operate on status and measure the initial contact offset value.
- ⑤ Set the instrument to operate off status and connect a standard capacitor (sample).
- ⑥ Set the instrument to operate on and perform contact initialization.
- ⑦ Connect the sample to be evaluated and perform a contact check.

Procedures ① to ⑥ are used to determine the level of contact evaluation. This value will remain in memory even after a power down.

The internal data can be read when the "CNX?", "CI1?" or "CI2?" GPIB commands are used to perform the contact check and the contact initialization. The "CNX?" command outputs the  $C_x$  value and the "CI1?" and "CI2?" commands output the  $n \times (C_{INI} - C_{IO}) + C_{IO}$  value.

CAUTION

1. The integral time of the contact check is determined when a contact initialization or contact initialization offset measurement is executed. The integral time of CNT? and CNX? after executing the CI2, CI2? and CO2 commands is 1PLC.
2. Contact initialization and contact initialization offset should be performed according to the same conditions (regarding generating voltage, jig, and cable) as the contact check.
3. A low insulation resistance in a jig or sample used in a contact initialization offset, contact initialization or contact check causes a large measurement error. If the resistance exceeds the range specified in table 3-7, measurements cannot be performed.
4. The response data of the "CNX?", "CI1?" or "CI2?" GPIB commands are internal measurement data whose accuracy is not guaranteed.

The V SOURCE step voltage for contact checking is automatically determined by the contact-checking judgment level and the V SOURCE generated voltage internally as shown in Table 3-8.

Select the sample and contact factor for contact initialization so that the contact-checking judgment level will be kept at the following range.

When  $V_s$  ranges between 0 and 100.00V →  $0 \leq C_{INI} \times n \leq$  approx. 10nF

When  $V_s$  ranges between 100.3 and 1000.0V

→  $0 \leq C_{INI} \times n \leq$  approx. 3nF

(When the level is out of the above range, an error occurs.)

Table 3 - 8 Contact Checking Judgment Level Range and Step Voltage

Generated voltage	Judgment level (C <sub>INI</sub> × n)			
	0 to approx. 90pF	approx. 90pF to approx. 900pF	approx. 900pF to approx. 3nF	approx. 3nF to approx. 10nF
0V to 10.000V	approx. 1V	approx. 100mV	approx. 10mV	approx. 10mV
10.03V to 100.00V	approx. 1V	approx. 100mV	approx. 100mV	approx. 100mV
100.3V to 1000.0V	approx. 1V	approx. 1V	approx. 1V	Impossible

For sample with no capacitance component or the capacitance of 0.5pF or less, judgment cannot be made. For the sample with the component "L" or when a large resistance is connected with the C<sub>i</sub> in series, judgment may be erroneously made.

- (1) The contact checking method.

Operation(① through ③)

[Before checking]

- ① Execute contact initialization.  
(See Item 4.3.2.)
- ② Set a contact level.  
(See Item 4.4.7.)

[Start of checking ]

③ Press the <sup>CONTACT</sup>  key, and the LED on the key lights.

③-1 Display panel state when contact is judged to be OK.

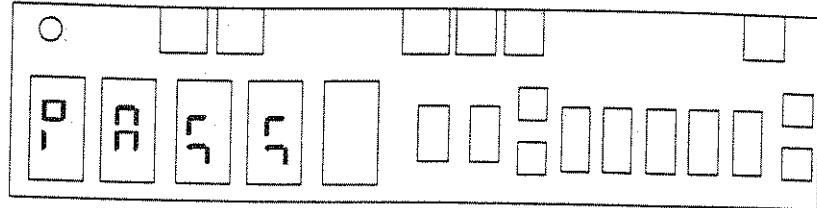

③-2 Display panel state when contact is judged to be NG

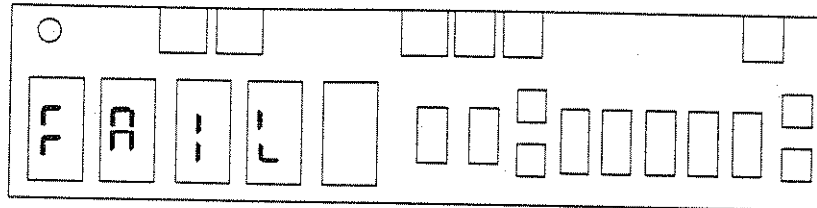

The high-pitched tone buzzer sounds.

③-3 Display panel state when contact cannot be judged

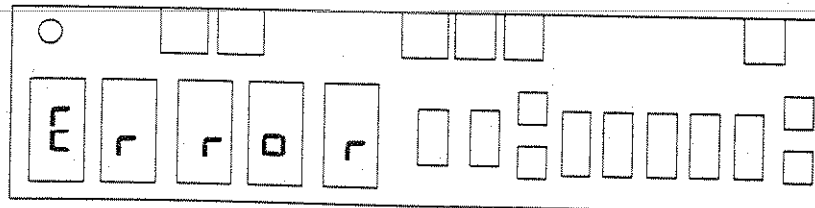

The high-pitched tone buzzer sounds.

Contact checking cannot be made when the standard sample exceeds the measurement range for contact initialization or the set contact level exceeds the judgment range. In the above cases, change the contact level or retry the contact initialization.

(The buzzer sounds only when it is set to ON.)  
After judgment on contact is displayed, the contact checking finishes and the panel returns to the normal measurement state. The LED on the key goes out.

(2) Limitations of contact check

The limitations are as follows :

- Check that only the material contacts by performing the contact initial with cable only.

No Limitations

- Compare the test piece contact initial capacity  $C_{INI}$  and the test piece capacity  $C_x$  in the contact check by connecting jigs to the test piece.

The insulation resistances of the test piece and jig have the following limitations :

①  $I_x = \frac{V_s}{R_x}$  shall be within the range as shown in Table 3-9.  
 $V_s$  = Input voltage  
 $R_x$  = Insulation resistances of jig and test piece

②  $R_x$  shall be more than the value shown in Table 3-9.

Table 3-9 The Range Where Comparison of Contact Initial and Contact Check is Available

Integral time of Contact Initial	$C_x, C_{IN}$	$V_s$			
		0 to 1.000V	1.000 to 10.000V	10.03 to 100.00V	100.3 to 1000.0V
2ms	0 to 100pF	More than 150MΩ	Less than 15nA	Less than 8nA	Less than 8nA
	100 to 1000pF		Less than 10nA		Less than 80nA
	1000 to 3000pF	More than 100MΩ		Less than 100nA	Less than 8nA
	3000 to 10000pF			Less than 80nA	—
	More than 10000pF	—	—	—	—
1PLC	0 to 100pF	More than 50MΩ	Less than 25nA	Less than 25nA	Less than 10nA
	100 to 1000pF				Less than 25nA
	1000 to 3000pF				Less than 10nA
	3000 to 10000pF				—
	More than 10000pF	—	—	—	—

The symbol "-" indicates that the contact initial is impossible.

<Example> When the integral time of contact initialization is 2ms at  $V_s=50V$ , the following insulation resistance is required when a 200pF contact check evaluation (in which the result is compared with the result of the 100pF check) is performed after a 100pF contact initialization.

$$R_x > 50V/8nA=6250M\Omega$$

(3) Noise in contact check or contact initial stage

2ms or 1PLC can be selective for the contact initial integral time of the AD converter when the contact occurs. The integral time in the contact check is determined by the contact initial integral time. While 2ms is usually set, it will be converted to 1PLC when the measurement is unstable due to noises. See "4.4.10" contact initial integral time" for this conversion. When you reset the integral time, carry out the contact initial again.

(4) Data output in contact check or contact initial

When the GPIB command "CI1?", "CI?" or "CNX?" is executed, the data of the contact check and contact initial. By processing these data with the external computer, upper and lower limits of the test piece capacity dispersion can be obtained. The data are output in [pF]. Since the accuracy of the data's absolute value is not guaranteed, use them as relative value.

### 3.3.9 Trigger Delay

Using this function, delay the time from when the trigger operation (internal trigger, trigger key, trigger command or external trigger signal) is completed to when the sampling starts.

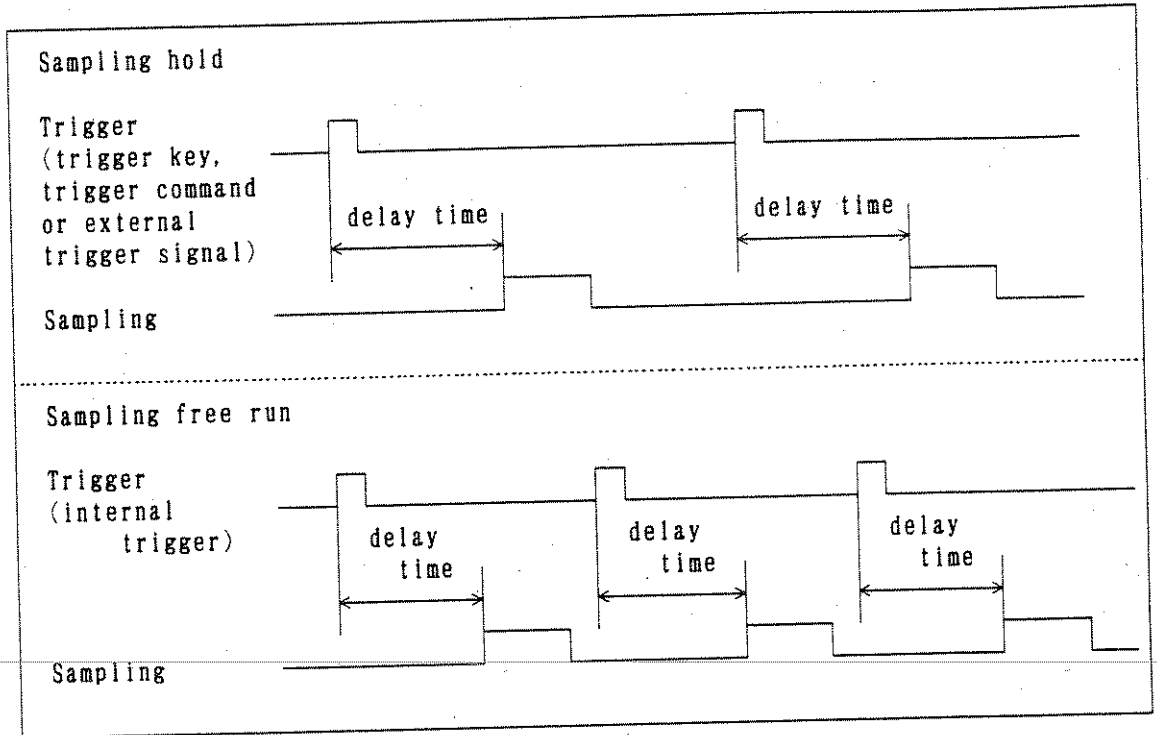

Figure 3 - 16 Trigger Delay

This function is used in the following measurement:

- Device measurement waiting for setting the setting time.
- Measurement of condenser I-t characteristic or R-t characteristic.
- Measurement of long-time insulation resistance characteristic using data memory function.



### 3.3.10 Autorange Delay

Using this function, the delay time, from when the measurement range is reset by the autorange operation mode to when the subsequent sampling starts, is set.

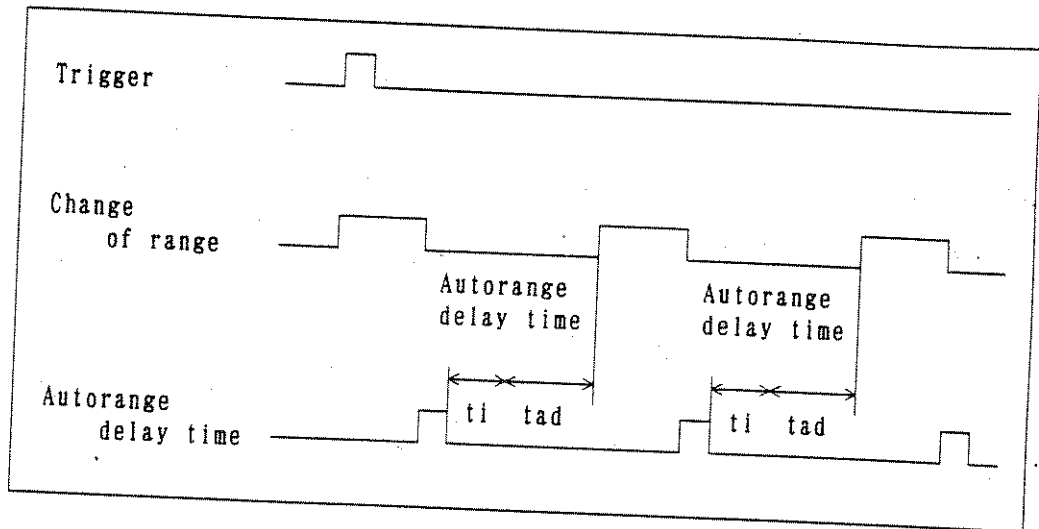

Figure 3 - 17 Autorange Delay

The autorange delay time is set based on the 200pA range, a standard, and the actual delay time in each range is as follows :

for  $tad/5^n \leq t_i$   $t = t_i + 10ms$   
 for  $tad/5^n > t_i$   $t = tad/5^n + 10ms$   
 ( $tad5^n \geq 1ms$ )

- $t_i$  : Internal setting time
- $tad$  : Autorange delay setting time
- $n$  : Range number (see Table 3-10)

Table 3 - 10 Delay Time in Each Range when Setting Autorange Delay

n	Current range after reset	Autorange delay time	Internal setting time $t_i$	Example of Actual delay time $t$ (Integration time 2ms)		
				tad=1ms	tad=1s	tad=9999s
0	200pA	Sat value tad	350ms	380ms	1030ms	9999030ms
1	2nA	tad/5	25ms	55ms	230ms	1999830ms
2	20nA	tad/5 <sup>2</sup>	5ms	35ms	70ms	399990ms
3	200nA	tad/5 <sup>3</sup>	5ms	35ms	38ms	80022ms
4	2 $\mu$ A	tad/5 <sup>4</sup>	2ms	32ms	32ms	16028ms
5	20 $\mu$ A	tad/5 <sup>5</sup>	2ms	32ms	32ms	3230ms
6	200 $\mu$ A	tad/5 <sup>6</sup>	2ms	32ms	32ms	670ms
7	2mA	tad/5 <sup>7</sup>	2ms	32ms	32ms	158ms
8	20mA	tad/5 <sup>8</sup>	2ms	32ms	32ms	56ms

This function is used in the following conditions :

- When an error occurs in the measurement since the internal settling time cannot provide a sufficient setting time after changing over the range at measurement of condenser in the autorange mode.
- When correct measurement data is obtained despite repeating the change-over the range.

When the range is changed over just before the final measurement after passing the charge time and measure time set in the measurement using the sequence program, the error may occur in the measurement data.

Set the autorange delay time to approx. quarter of the charge time in programs 0 through 4. Set it to approx. half of measured time in program 5.

#### 4. DESCRIPTION OF PARAMETER KEYS

This section describes parameters keys.

## 4.1 Basic Usage of Parameter Keys

Parameter keys have several functions respectively. Each key changes various settings and executes functions. Functions depend on the normal measurement mode, sequence program mode, and calibration mode.

The following describes parameter keys under the normal measurement mode.

For the sequence program mode, see Section 5.3 "Program Parameter setting". For the calibration mode, see Section 9.2 "Calibration". Table 4-1 shows various parameter keys.

Table 4 - 1 Parameter Keys

Parameter keys	MEAS <input type="checkbox"/> CAL <input type="checkbox"/> COEF <input type="checkbox"/> I/O <input type="checkbox"/> MEM <input type="checkbox"/>	Used to change various settings and execute functions.
Parameter setting change key	CHANGE <input type="checkbox"/>	Used to change over predetermined setting.
Parameter setting registration key	EXIT <input type="checkbox"/>	Used to exit from the setting mode after registration.

See Table 4-2 "Parameter Key Functions" and Figure 4-1 "Basic Usage of Parameter Keys".

### Operation (① through ④)

- ① Press a parameter key under the normal measurement mode.
- ② The present set state of the specified parameter is displayed according to the pressed parameter key and the number of pressing times. (See Table 4-2.)
- ③ Setting change includes the following three methods.
  - Select an item among the predetermined settings with the <sup>CHANGE</sup> .
  - Input optional value using the keys  to , ,  <sub>0</sub> <sub>9</sub> <sub>+</sub> <sub>-</sub>.
  - Make setting using the above two methods.
- ④ Resetting after changing to a required setting  
Register a new setting to complete the setting. Resetting includes the following two methods.
  - When the <sup>EXIT</sup>  is pressed, a new setting is registered and the state exits from the setting mode to return to the normal measurement mode.

- When the parameter key pressed in the above Item ② is pressed again, a new setting is registered and the state moves to the next setting mode.

Table 4 - 2 Parameter Key Functions

1. Parameter key : <input type="checkbox"/> <sup>MEAS</sup>		
Setting contents	Operation 1	Operation 2
① Setting of integration time	Press the <input type="checkbox"/> <sup>MEAS</sup> once.	INTEG → 2ms → 1PLC → 5PLC → 10PLC → 10PLC×4 → 10PLC×8 → 10PLC×16 } Change them with the CHANGE <input type="checkbox"/> for selection.
② Setting of AD CAL	Press the <input type="checkbox"/> <sup>MEAS</sup> twice.	AD CAL → ON } Change them with the → OFF } CHANGE <input type="checkbox"/> for selection.
③ Setting of input amplifier gain	Press the <input type="checkbox"/> <sup>MEAS</sup> three times.	GAIN → ×1 → ×10 → ×100 → ×10000 } Change them with the CHANGE <input type="checkbox"/> for selection.
④ Setting of output-voltage current limiter	Press the <input type="checkbox"/> <sup>MEAS</sup> four times.	LIMIT → 300mA → 100mA → 10mA } Change them with the CHANGE <input type="checkbox"/> for selection.
⑤ Setting of autorange up/down level	Press the <input type="checkbox"/> <sup>MEAS</sup> five times.	A. R. LVL → 20000 → 2000 → 200 } Change them with the CHANGE <input type="checkbox"/> for selection.
⑥ Setting of unit indication	Press the <input type="checkbox"/> <sup>MEAS</sup> six times.	UNIT → Symble } Change them with the → Exponent } CHANGE <input type="checkbox"/> for selection.
⑦ Setting of trigger delay time	Press the <input type="checkbox"/> <sup>MEAS</sup> seven times.	DELAY T data — Input data with numeric keys.
⑧ Setting of autorange delay time	Press the <input type="checkbox"/> <sup>MEAS</sup> eight times.	A. R. DLYT data — Input data with numeric keys.
⑨ Press the <input type="checkbox"/> <sup>MEAS</sup> nine times, and the state returns to ①.		

Table 4 - 2 Parameter Key Functions (Cont'd)

2. Parameter : <input type="checkbox"/> CAL		
Setting contents	Operation 1	Operation 2
① Execute zero cancel.	Press the <input type="checkbox"/> CAL once.	ZC <input type="checkbox"/> OFF <input type="checkbox"/> Execution } CHANGE <input type="checkbox"/> for execution.
② Execute contact initialization offset measurement.	Press the <input type="checkbox"/> CAL twice.	C-inoF <input type="checkbox"/> OFF <input type="checkbox"/> Execution } CHANGE <input type="checkbox"/> for execution.
③ Execute contact initialization.	Press the <input type="checkbox"/> CAL three.	C-INIT <input type="checkbox"/> OFF <input type="checkbox"/> Execution } CHANGE <input type="checkbox"/> for execution.
④ Execute self-test.	Press the <input type="checkbox"/> CAL four times.	TEST <input type="checkbox"/> OFF <input type="checkbox"/> Execution } CHANGE <input type="checkbox"/> for execution.
⑤ Press the <input type="checkbox"/> CAL five times, and the state returns to ①.		
3. Parameter : <input type="checkbox"/> I/O		
Setting contents	Operation 1	Operation 2
F o r  R 8 3 4 0	① Setting of GPIB address	Press the <input type="checkbox"/> I/O once.
	② Setting of power frequency	Press the <input type="checkbox"/> I/O twice.
	③ Press the <input type="checkbox"/> I/O three times, and the state returns to ①.	
F o r  R 8 3 4 0 A	① Setting of DA OUTPUT	Press the <input type="checkbox"/> I/O once.
		DA <input type="checkbox"/> OFF <input type="checkbox"/> AAA99 <input type="checkbox"/> 1AAA9 <input type="checkbox"/> 19AAA <input type="checkbox"/> 199AA <input type="checkbox"/> BBB99 <input type="checkbox"/> 1BBB9 <input type="checkbox"/> 19BBB <input type="checkbox"/> 199BB } CHANGE <input type="checkbox"/> for selection.

Table 4 - 2 Parameter Key Functions (Cont'd)

Setting contents	Operation 1	Operation 2
F o r R 8 3 4 0 A	② Setting of BCD OUTPUT	Press the $\overset{I/O}{\square}$ twice.
	③ Setting of GPIB address	Press the $\overset{I/O}{\square}$ three times.
	④ Setting of power frequency	Press the $\overset{I/O}{\square}$ four times.
	⑤ Press the $\overset{I/O}{\square}$ five times, and the state returns to ①.	
BCD $\left. \begin{array}{l} \rightarrow \text{OFF} \\ \rightarrow \text{BCD} \\ \rightarrow \text{BIN} \end{array} \right\} \text{CHANGE } \square \text{ for selection.}$ Change them with the $\square$ for selection.		
GPIB $\left. \begin{array}{l} \rightarrow \text{A-XX (data)} \\ \rightarrow \text{HA-XX (data)} \\ \rightarrow \text{0-} \\ \rightarrow \text{HO-} \end{array} \right\} \text{CHANGE } \square \text{ for selection.}$ Change them with the $\square$ for selection.		
LINE F $\left. \begin{array}{l} \rightarrow \text{50Hz} \\ \rightarrow \text{60Hz} \end{array} \right\} \text{CHANGE } \square \text{ for selection.}$ Change them with the $\square$ for selection.		
4. Parameter key : $\overset{COEF}{\square}$		
Setting contents	Operation 1	Operation 2
① Selection of COMPARE upper level	Press the $\overset{COEF}{\square}$ once.	UPPER polarity + data + unit — Change them with the $\overset{CHANGE}{\square}$ for selection.
② Setting of COMPARE lower level	Press the $\overset{COEF}{\square}$ twice.	LOWER polarity + data + unit — Change them with the $\overset{CHANGE}{\square}$ for selection.
③ Setting of resistance measurement indication	Press the $\overset{COEF}{\square}$ three times.	RM $\left. \begin{array}{l} \rightarrow \text{NORMAL} \\ \rightarrow \text{VOLUME} \\ \rightarrow \text{SURFACE} \end{array} \right\} \text{CHANGE } \square \text{ for selection.}$ Change them with the $\square$ for selection.
④ Setting of electrode for volume and surface resistivities	Press the $\overset{COEF}{\square}$ four times.	E. DIM $\left. \begin{array}{l} \rightarrow \phi 50 \text{ (JIS)} \\ \rightarrow \phi 70 \text{ (JIS)} \\ \rightarrow \text{Optional dimension} \end{array} \right\} \text{CHANGE } \square \text{ for selection.}$ Change them with the $\square$ for selection.

Table 4 - 2 Parameter Key Functions (Cont'd)

Setting contents	Operation 1	Operation 2
⑤ Setting of optional electrode coefficient	Press the <sup>COEF</sup> <input type="checkbox"/> five times.	V. COEF/S. COEF } Change them with the <sup>CHANGE</sup> <input type="checkbox"/> for selection. <input type="checkbox"/> Volume resistivity <input type="checkbox"/> Surface resistivity + data — Input data with numeric keys.
⑥ Setting of sample thickness for measurement of volume resistivity	Press the <sup>COEF</sup> <input type="checkbox"/> six times.	SAMPL t data — Input data with numeric keys.
⑦ Selection of contact level	Press the <sup>COEF</sup> <input type="checkbox"/> seven times.	CONTACT <input type="checkbox"/> ×10 <input type="checkbox"/> ×5 <input type="checkbox"/> ×2 <input type="checkbox"/> ×1 <input type="checkbox"/> ×0.5 <input type="checkbox"/> ×0.2 <input type="checkbox"/> ×0.1 } Change them with the <sup>CHANGE</sup> <input type="checkbox"/> for selection.
⑧ Setting of buzzer	Press the <sup>COEF</sup> <input type="checkbox"/> eight times.	BZ <input type="checkbox"/> ON <input type="checkbox"/> OFF } Change them with the <sup>CHANGE</sup> <input type="checkbox"/> for selection.
⑨ Setting of indication	Press the <sup>COEF</sup> <input type="checkbox"/> nine times.	DISP <input type="checkbox"/> ON <input type="checkbox"/> OFF } Change them with the <sup>CHANGE</sup> <input type="checkbox"/> for selection.
⑩ Setting of contact initial integration time	Press the <sup>COEF</sup> <input type="checkbox"/> ten times.	CNT, IT <input type="checkbox"/> 2ms <input type="checkbox"/> 1PLC } Change them with the <sup>CHANGE</sup> <input type="checkbox"/> for selection.
⑪ Press the <sup>COEF</sup> <input type="checkbox"/> eleven times, and the state returns to ①.		
5. Parameter : <sup>MEM</sup> <input type="checkbox"/>		
Setting contents	Operation 1	Operation 2
① Store measured data.	Press the <sup>MEM</sup> <input type="checkbox"/> once	STORE <input type="checkbox"/> OFF <input type="checkbox"/> ON } Change them with the <sup>CHANGE</sup> <input type="checkbox"/> for selection.
② Recall the stored measured data.	Press the <sup>MEM</sup> <input type="checkbox"/> twice.	RECALL <input type="checkbox"/> OFF <input type="checkbox"/> Recall data No. } Make setting with the <sup>CHANGE</sup> <input type="checkbox"/> or numeric keys.
③ Press the <sup>MEM</sup> <input type="checkbox"/> three times, and the state returns to ①.		



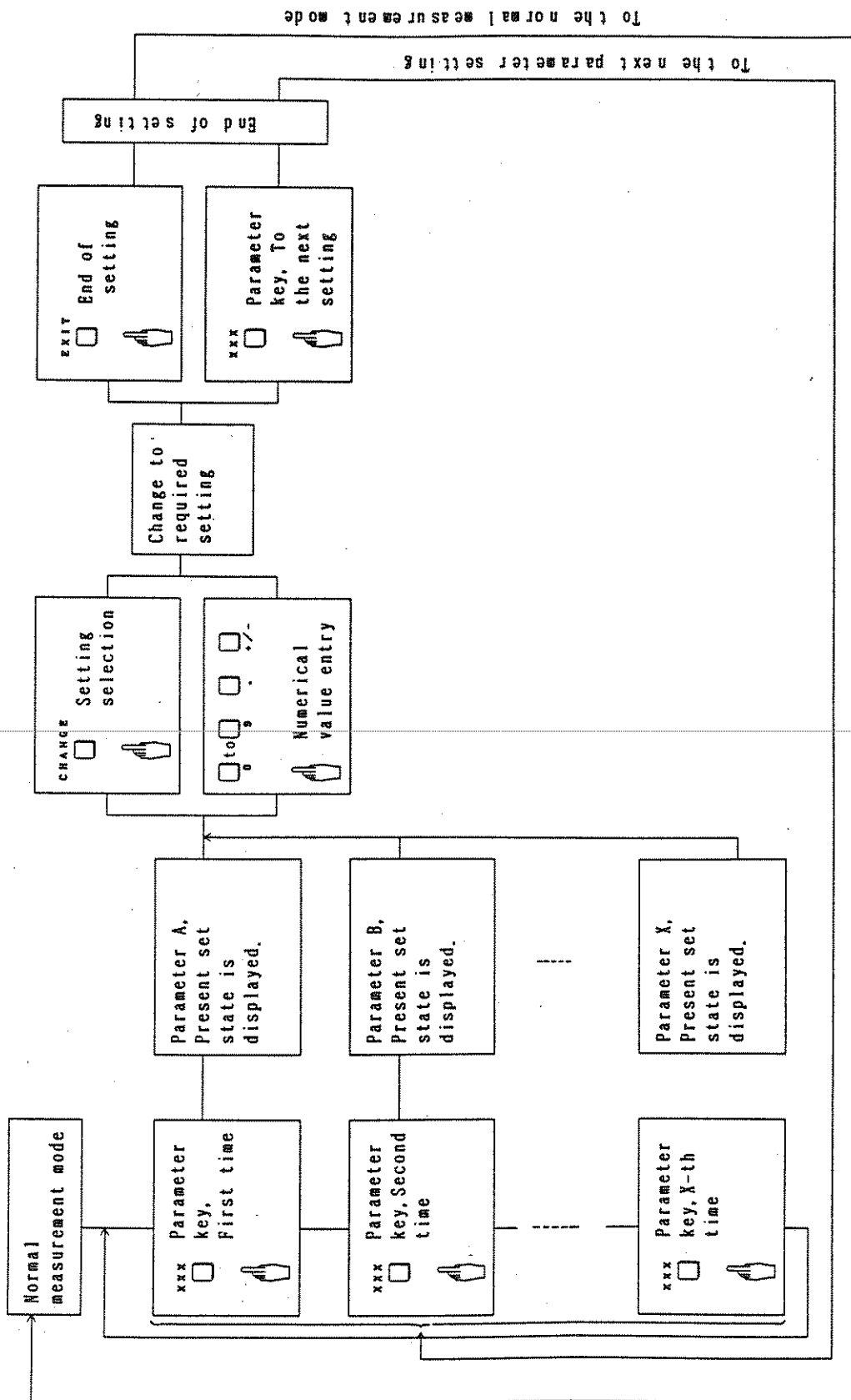

Figure 4 - 1 Basic Usage of Parameter Keys

## 4.2 Various MEAS-Key Setting Methods

### 4.2.1 Integral Time

The following describes how to set the input-signal integration time of the A/D converter.

Operation ( ① through ③ )

- ① Press the <sup>MEAS</sup>  once, and the indication **INTEG** appears.
- ② Press the <sup>CHANGE</sup>  until the required integration time appears.

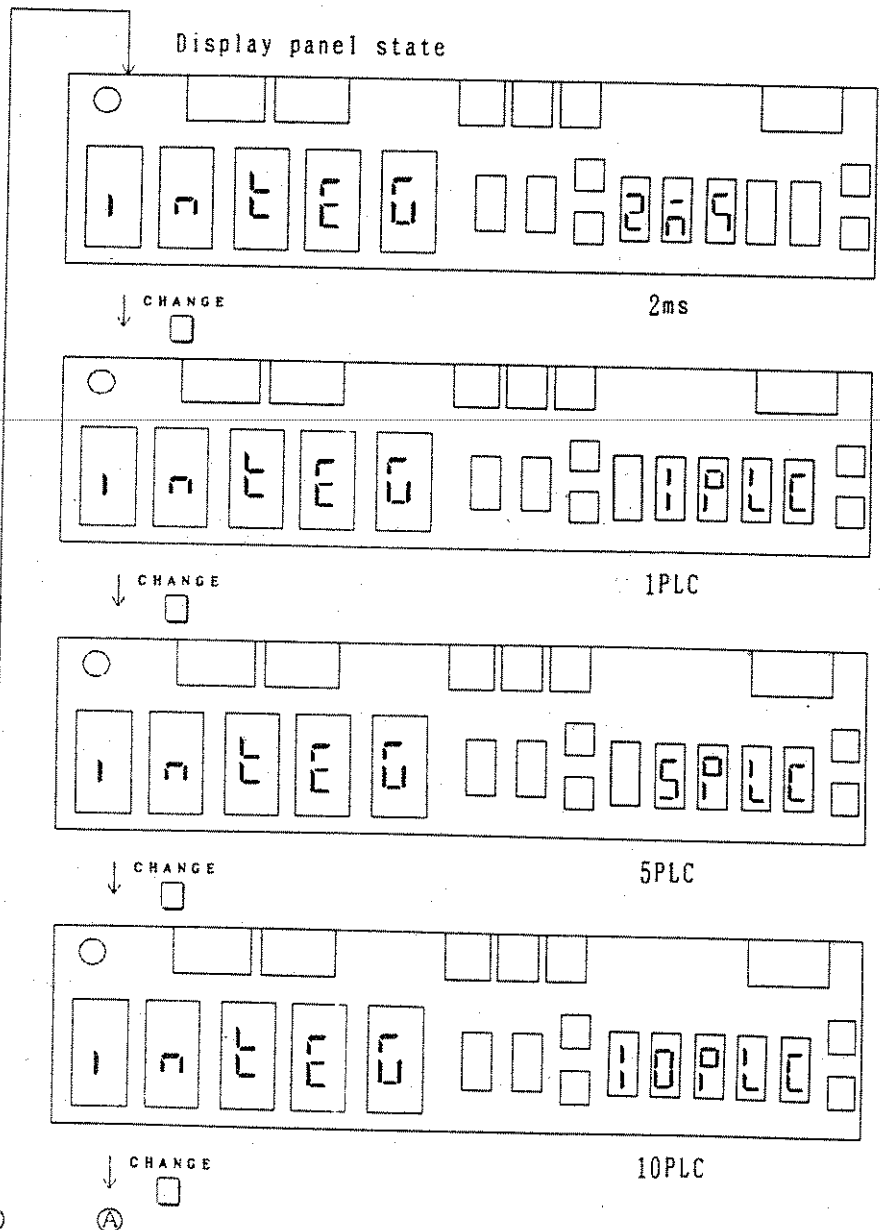

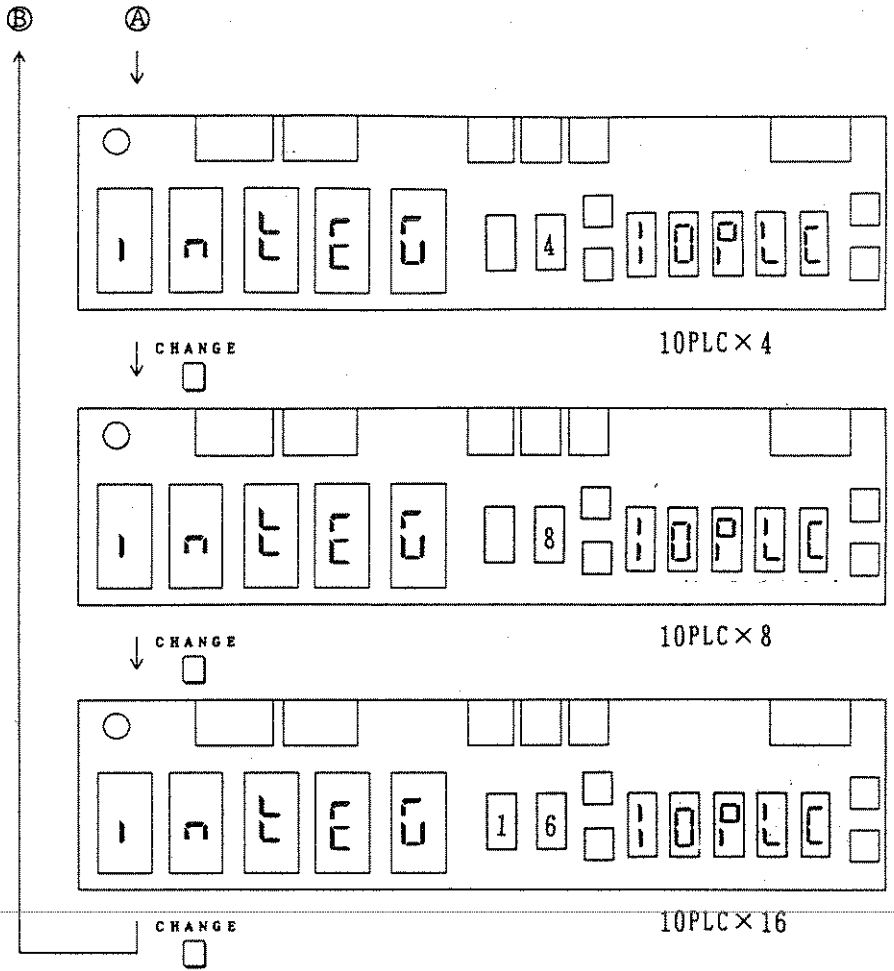

③ When the  key is pressed, the setting ends.

### 4.2.2 AD CAL

The following describes how to set AD CAL to ON or OFF.

Operation ( ① through ③ )

① Press the <sup>MEAS</sup>  twice, and the indication  
A D C A L appears.

② Press the <sup>CHANGE</sup>  to set ON or OFF. Whenever the <sup>CHANGE</sup>  is pressed, the setting is changed over.

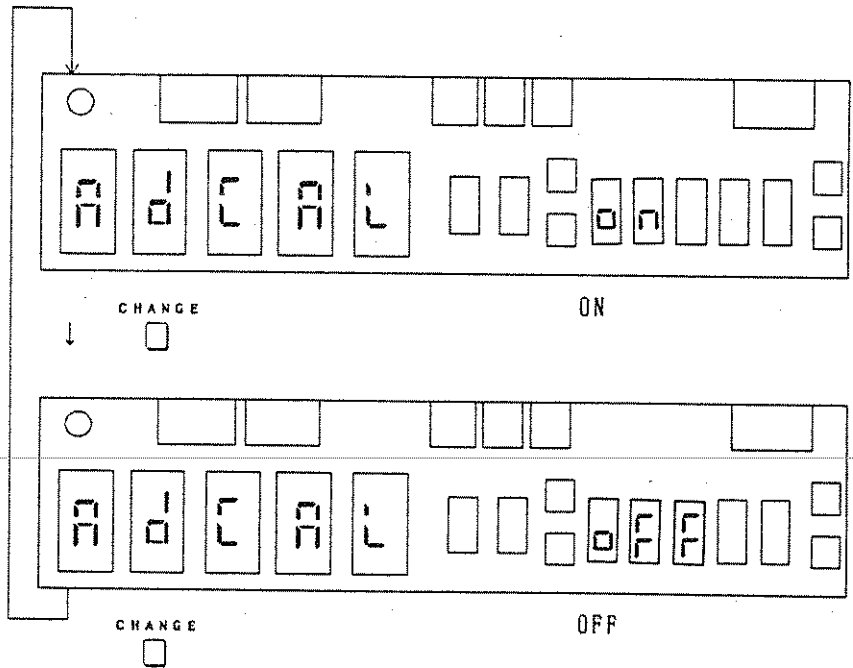

③ When the <sup>EXIT</sup>  is pressed, the setting ends.

### 4.2.3 Input Amplifier Gain

The following describes how to set input amplifier gain.

Operation ( ① through ③ )

- ① Press the <sup>MEAS</sup>  three times, and the indication

G A I N appears.

- ② Press the <sup>CHANGE</sup>  until the required input amplifier gain appears.

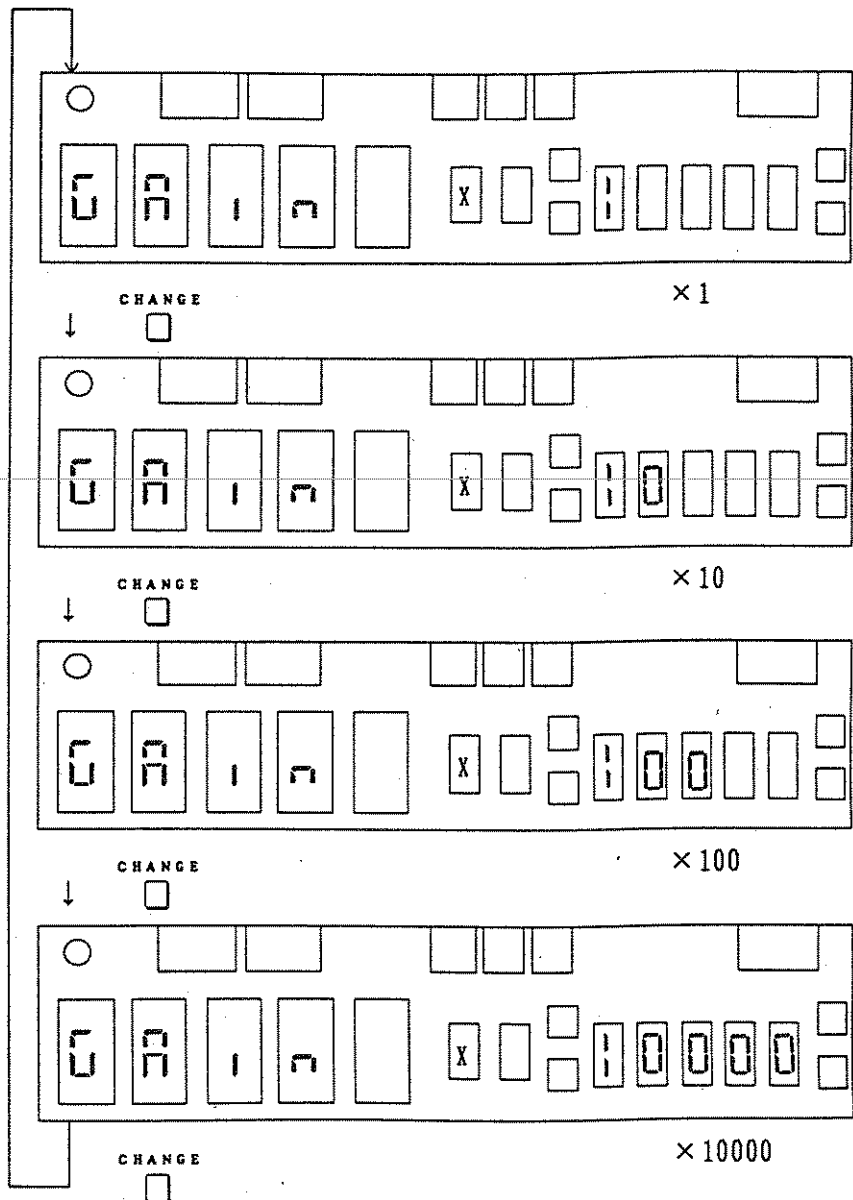

- ③ When the <sup>EXIT</sup>  is pressed, the setting ends.

## 4.2.4 Current Limiter (Current Compliance)

The following describes how to set V-SOURCE current limiter.

Operation ( ① through ③ )

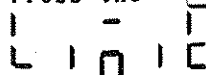
- ① Press the <sup>MEAS</sup>  four times, and the indication  
 appears.

- ② Press the <sup>CHANGE</sup>  until the required current limiter appears.

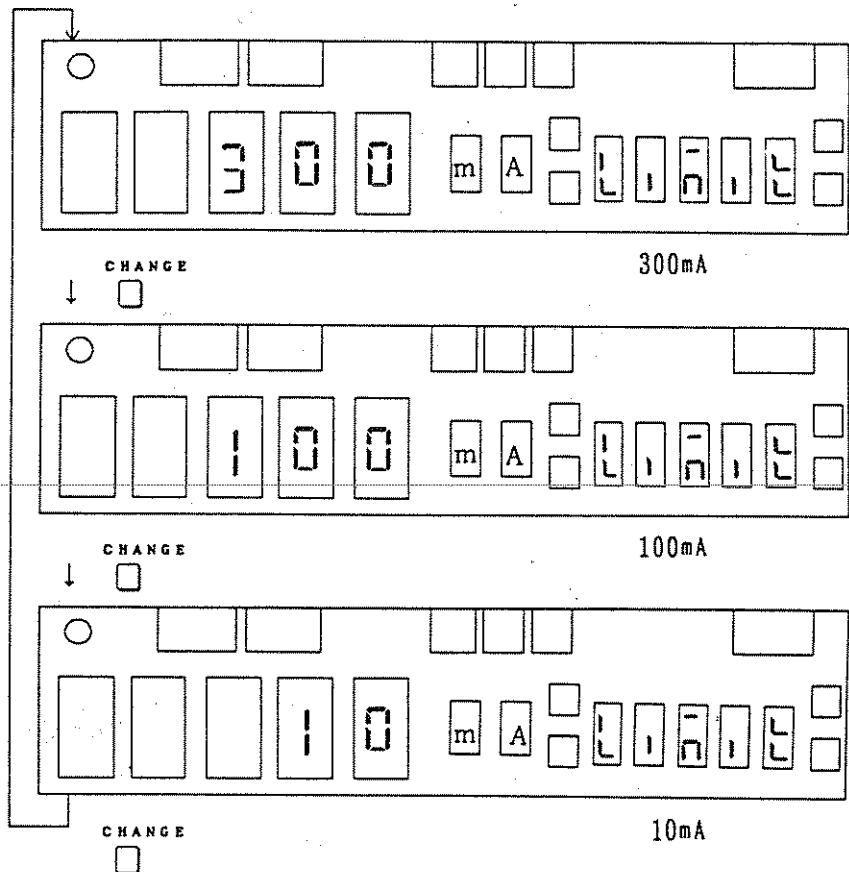

- ③ When the <sup>EXIT</sup>  is pressed, the setting ends.

## 4.2.5 Auto Range Up/down Level

The setting realizes quick-response measurement corresponding to the necessary number of digits.

The judgment value includes the following three types.

- (1) : Up 20000 Down 1799
- (2) : Up 2000 Down 179
- (3) : Up 200 Down 17

When "IT=2ms" is set, however, the operation same with that in Item (2) is executed even if the data in Item (1) is set because "1999" is the full scale. For the highest range and manual range, "19999" is the full scale regardless of settings. The following describes how to set auto range up/down level.

Operation (① through ③)

- ① Press the  <sup>MEAS</sup> five times, and the indication

A . r . L U L appears.

- ② Press the  <sup>CHANGE</sup> until the required auto range up/down level appears.

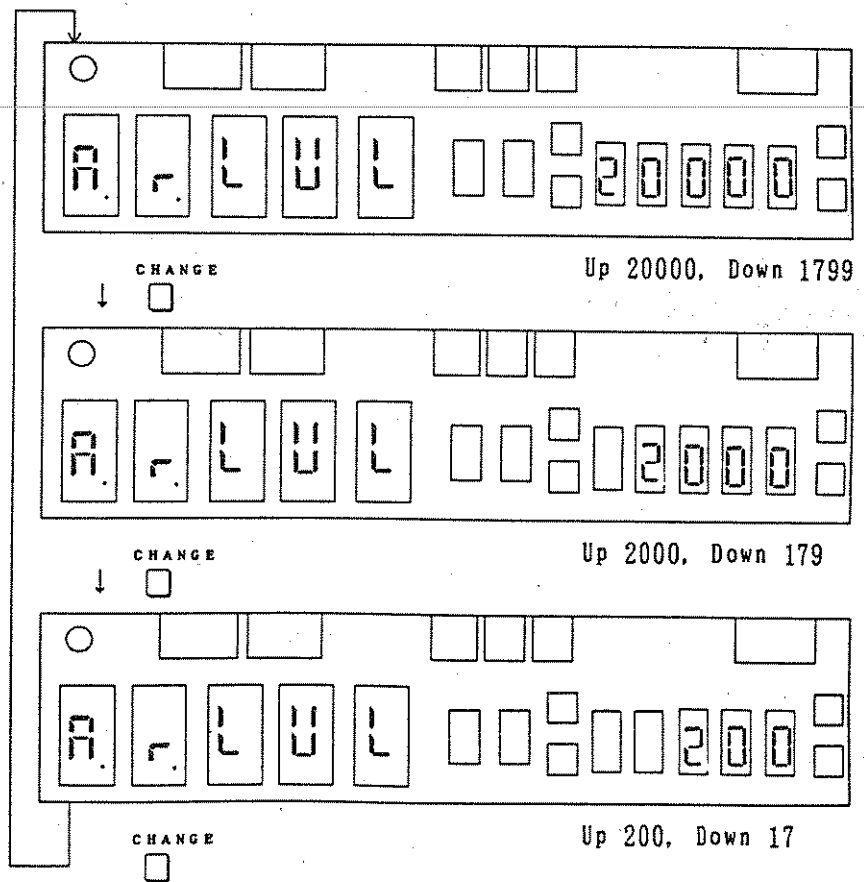

- ③ When the  <sup>EXIT</sup> is pressed, the setting ends.

## 4.2.6 Unit Indication

The unit indication includes the exponent and symbol units. The exponent unit indication is used for the measurement of volume and surface resistivities regardless of settings. The following describes how to set the unit indication of measured values.

Operation (① through ③)

① Press the <sup>MEAS</sup>  six times, and the indication **U n i t** appears.

② Press the <sup>CHANGE</sup>  to set the symbol or exponent unit. Whenever the <sup>CHANGE</sup>  is pressed, the setting is changed over.

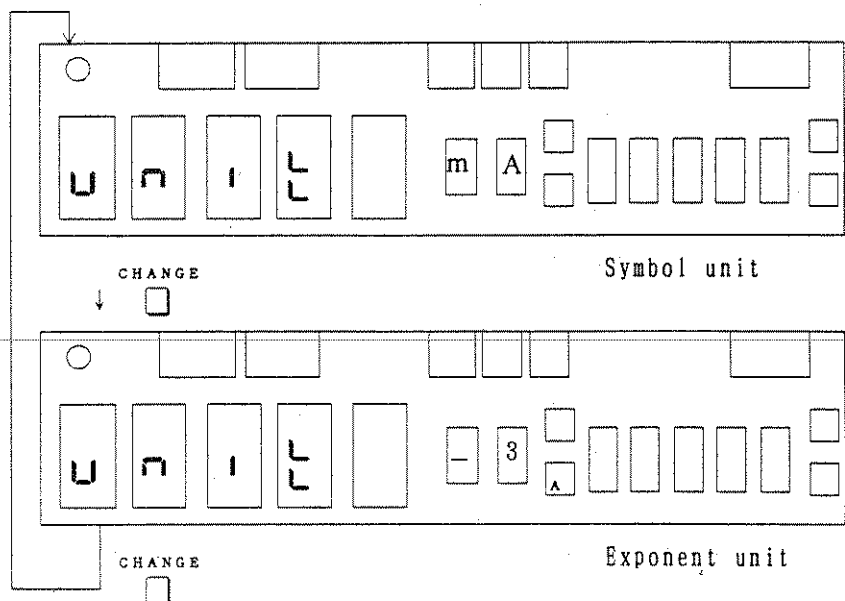

③ When the <sup>EXIT</sup>  is pressed, the setting ends.



## 4.2.7 Trigger Delay

The following describes how to set trigger delay time.

Operation (① through ③)

- ① Press the <sup>MEAS</sup>  seven times, and the indication

DELA Y appears.

- ② Change the present set value to the required set value. To change the setting to "12.345sec", for example:

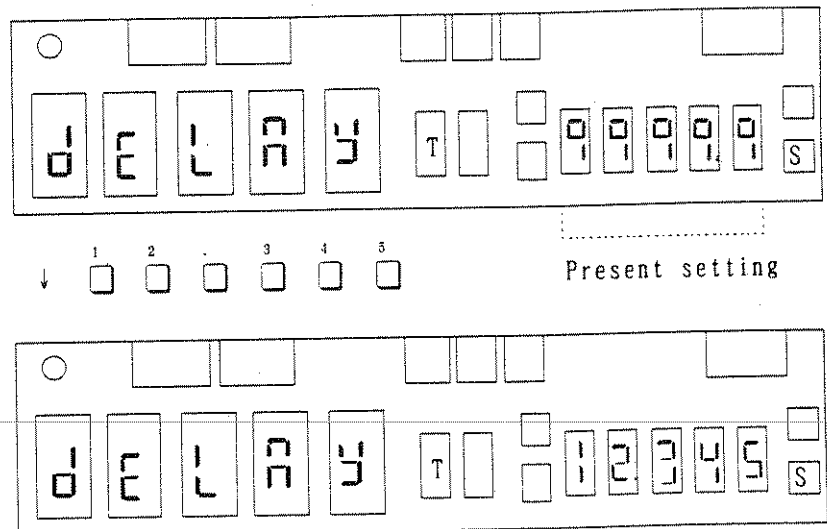

- ③ When the <sup>EXIT</sup>  is pressed, the setting ends.

## CAUTION

- The trigger delay time setting range is 0 to 9999.9 sec. If a value out of the range is set, an input error occurs when the <sup>EXIT</sup>  is pressed.
- If you input an incorrect value, press the  <sub>CE</sub>. Then the preceding set value appears and you can input a new value.

## 4.2.8 Autorange Delay

The following describes how to set Autorange delay time.

Operation (① through ③)

- ① Press the <sup>MEAS</sup>  eight times, and the indication

A r . d L Y appears.

- ② Change the present set value to the required set value. To change the setting to "12.345sec", for example:

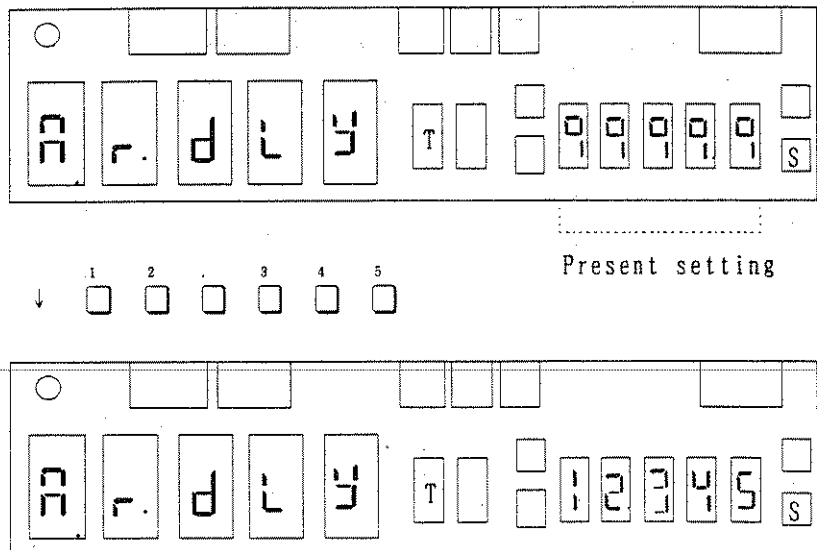

- ③ When the <sup>EXIT</sup>  is pressed, the setting ends.

## CAUTION

- The autorange delay time setting range is 0 to 9999.9 sec. If a value out of the range is set, an input error occurs when the <sup>EXIT</sup>  is pressed.
- If you input an incorrect value, press the  <sub>CE</sub>. Then the preceding set value appears and you can input a new value.

## 4.3 Various CAL-key Setting Methods

### 4.3.1 Zero Cancel

When the zero cancel operation is executed, the input amplifier is reset and the input-amplifier offset is canceled. Execute the zero cancel operation when zero is deviated.

The following describes how to execute zero cancel.

Operation (① through ③)

- ① Press the  <sup>CAL</sup> once, and the indication Z C appears.
- ② Press the  <sup>CHANGE</sup> for execution.

Display panel state for execution

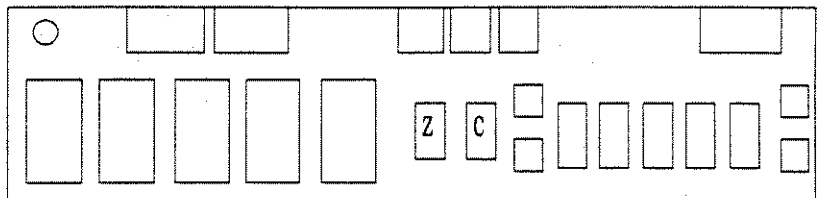

CHANGE

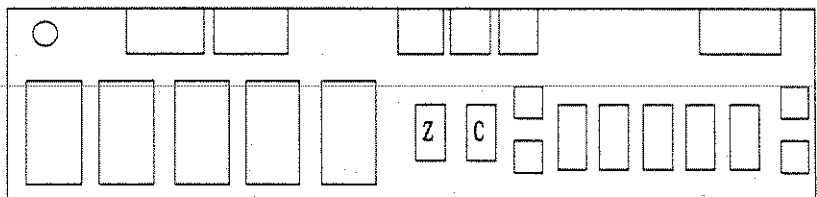

During execution of  
zero cancel operation

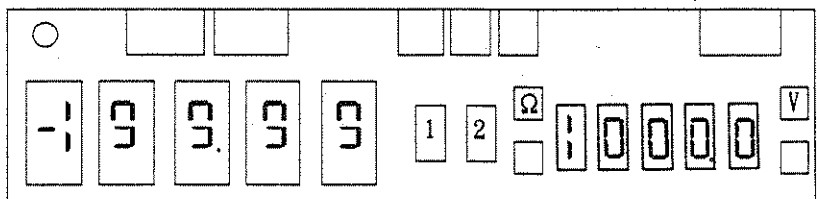

End of zero cancel operation

- ③ When the zero cancel operation ends, the state returns to the normal measurement mode.

### 4.3.2 Contact Initialization Offset Measurement

The following is a description of contact initialization offset measurement procedures.

Operation (① though ③)

① Press  <sup>CAL</sup> twice to display "E. i n o f".

② Press  <sup>CHANGE</sup> to execute the program.

Panel display screens during operation

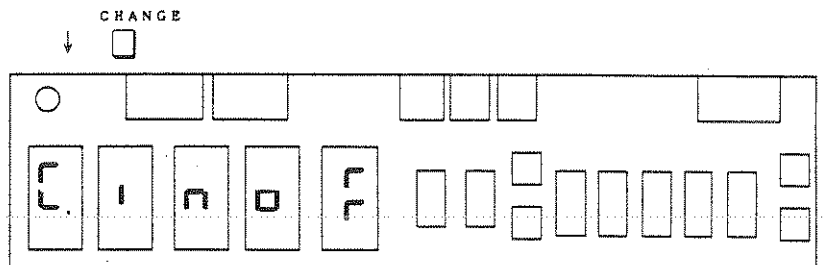
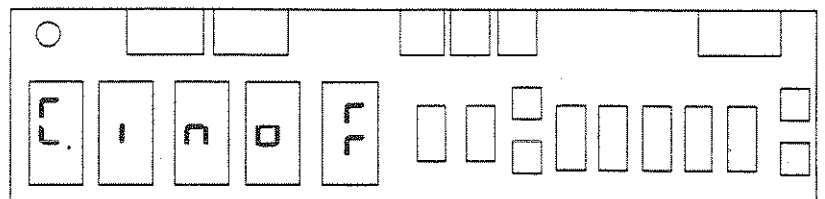

Screens displayed during execution of contact initialization offset measurement

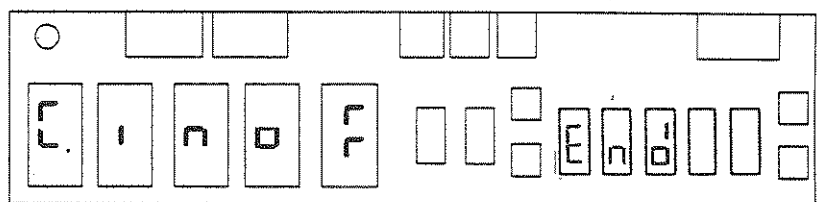

Terminating contact initialization offset measurement

③ Press  <sup>EXIT</sup> to terminate measurement.

The following screen is displayed when the contact initialization offset measurement ends abnormally.

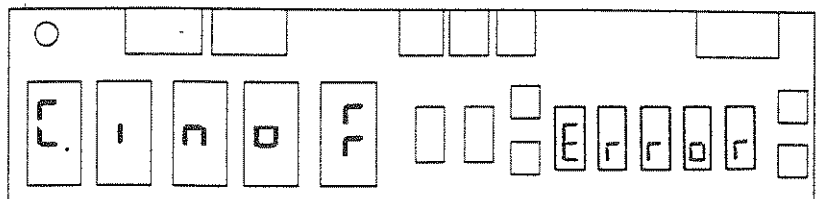

Contact initialization offset measurement error  
(High pitch buzzer goes off.)

### 4.3.3 Contact Initialization

The following describes how to execute contact initialization.

Operation (① through ③)

- ① Press the  <sup>CAL</sup> twice, and the indication

 appears.

- ② Press the  <sup>CHANGE</sup> for execution.

Display panel state for execution

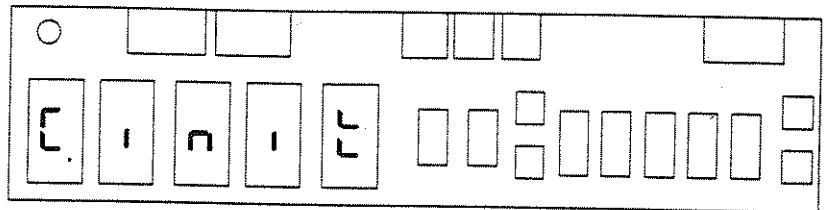

<sup>CHANGE</sup>

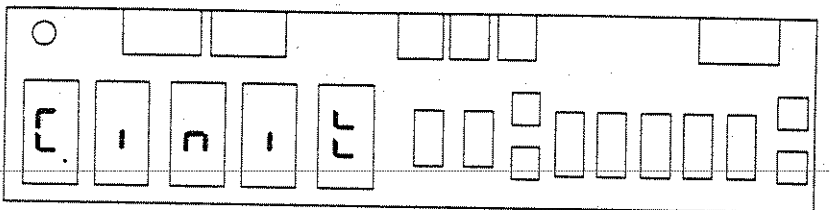

During execution of  
contact initialization

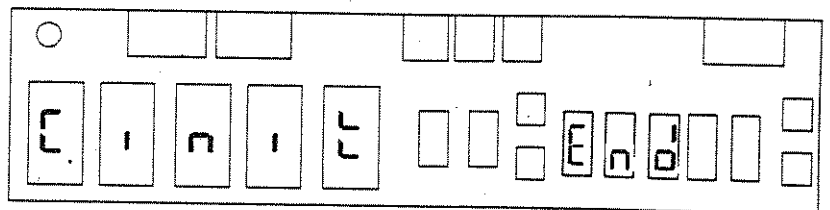

End of contact initialization

- ③ When the  <sup>EXIT</sup> is pressed, the operation ends. If the contact initialization does not normally end, the following indication appears.

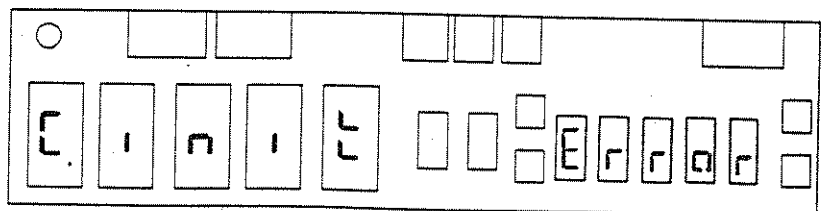

Contact initialization error  
(The high-pitched tone buzzer sounds.)

To decrease the error in the contact check and contact initial, use the same test piece and set the same voltage generating value (V SOURCE.)

When the connecting condition between the meter and a sample is changed, execute the contact initialization again. The measured data for contact initialization is stored even if the power is turned off.

#### 4.3.4 Self-test

When the self-test is executed, the following test items are displayed in order of number.

1. LOGIC ROM sum checking
2. E<sup>2</sup>PROM R/W checking
3. RAM R/W checking
4. ANALOG ROM sum checking
5. SCI checking
6. CAL primary sum checking
7. CAL secondary sum checking
8. Panel parameter sum checking
9. A/D checking
10. Input-, 100V-, and 1000V-amplifier checking

If each test is NG after it is executed, the error is displayed and the self-test ends. For error contents, see Item 3.1.2 "Various messages". The following describes how to execute self-test.

#### Operation (① through ③)

- ① Press the  <sup>CAL</sup> fore times, and the indication  
 ㄣ ㄷ ㄱ ㄣ appears.

- ② Press the  <sup>CHANGE</sup> for execution.

Display panel state for execution

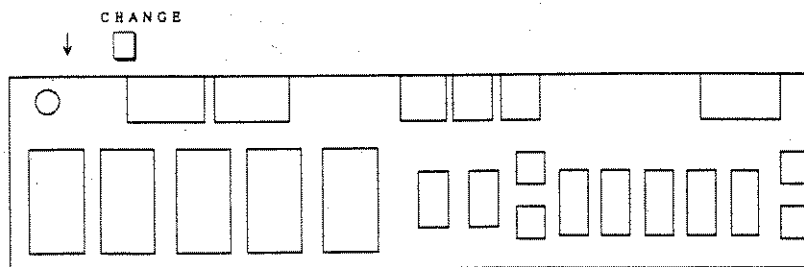
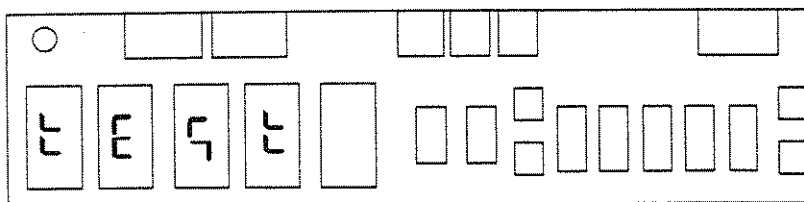

During execution of self-test, All LEDs go out.

Ⓐ ↓

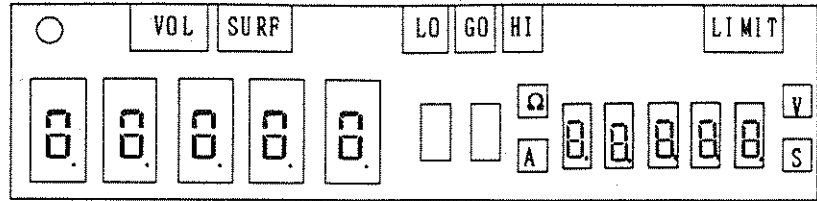

During execution of each test,  
ALL LEDs light.

↓

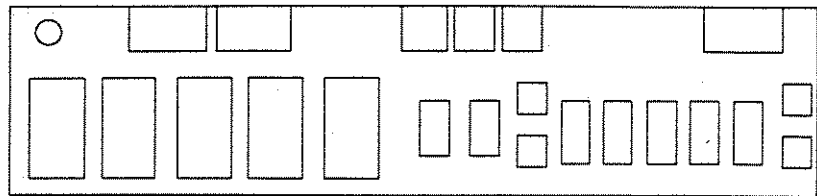

End of each test,  
All LEDs go out.

↓

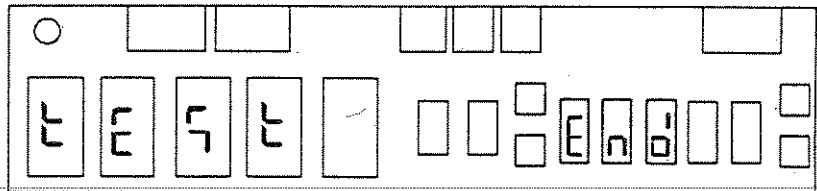

End of self-test

- ③ When the <sup>EXIT</sup>  is pressed, the state exits from the mode and returns to the normal measurement state.

## 4.4 Various COEF-key Setting Methods

## 4.4.1 Upper Level

The following describes how to set the upper level for comparison in the COMPARE mode. The setting unit indication includes the symbol and exponent units. For how to set unit indication, see Item 4.2.6 "Unit indication".

(1) For symbol unit indication

Operation (① through ③)

① Press the <sup>COEF</sup>  once, and the indication

U P P E R appears.

The set value of the present upper level is displayed.

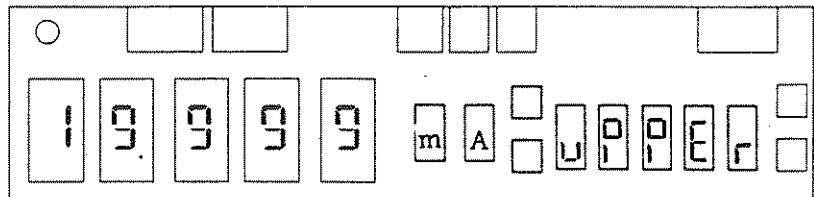

Present setting

② To change the present set value, input a new value with numerical keys. To change the setting to 123.45 pA, for example:

②-1 Input numeric values as follows:

Press the      and .

1 2 3 4 5

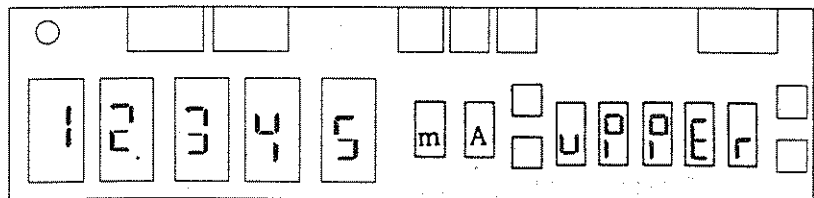

②-2 Set the range.

Press the <sup>CHANGE</sup>  until the required range appears.



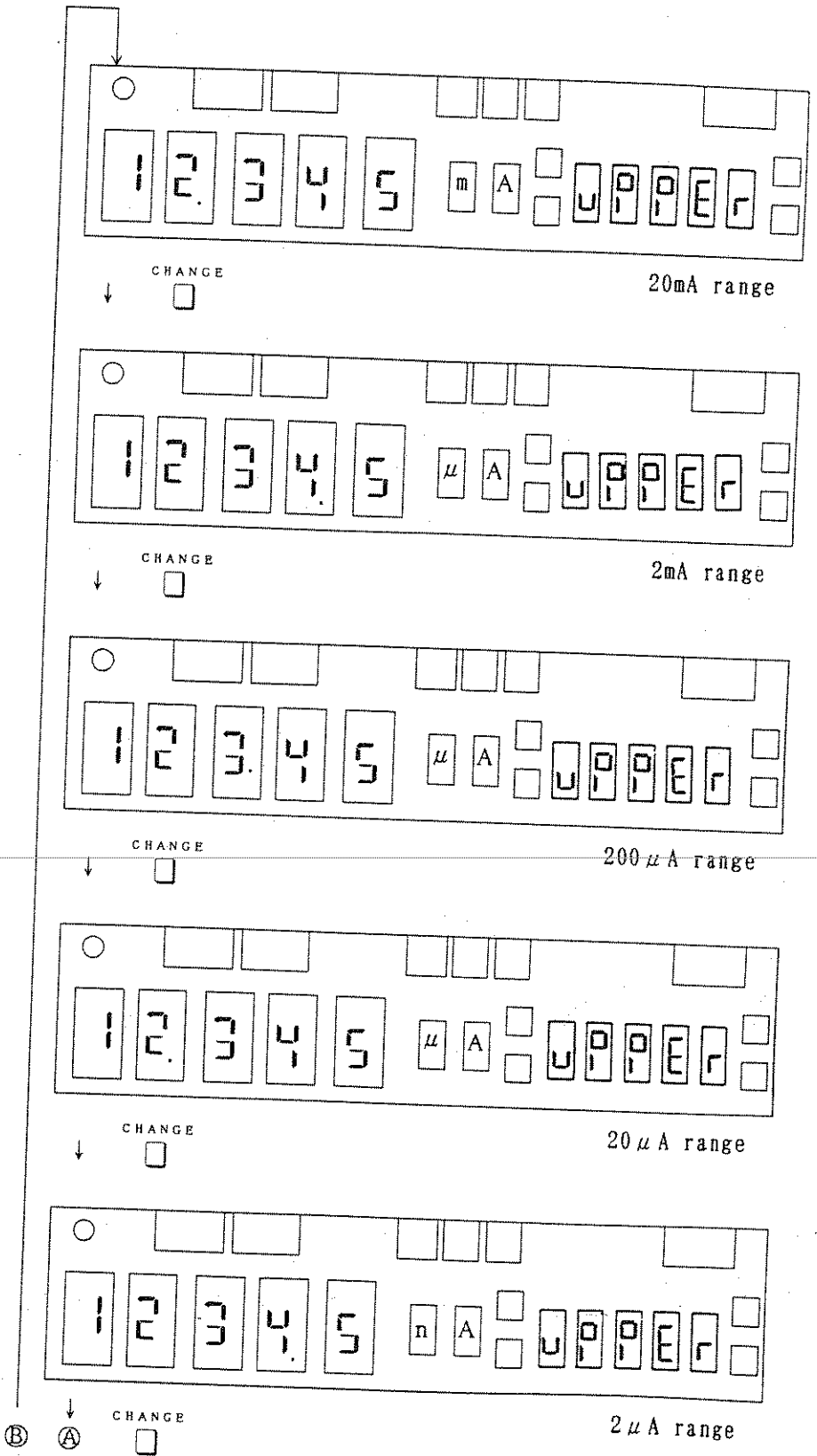

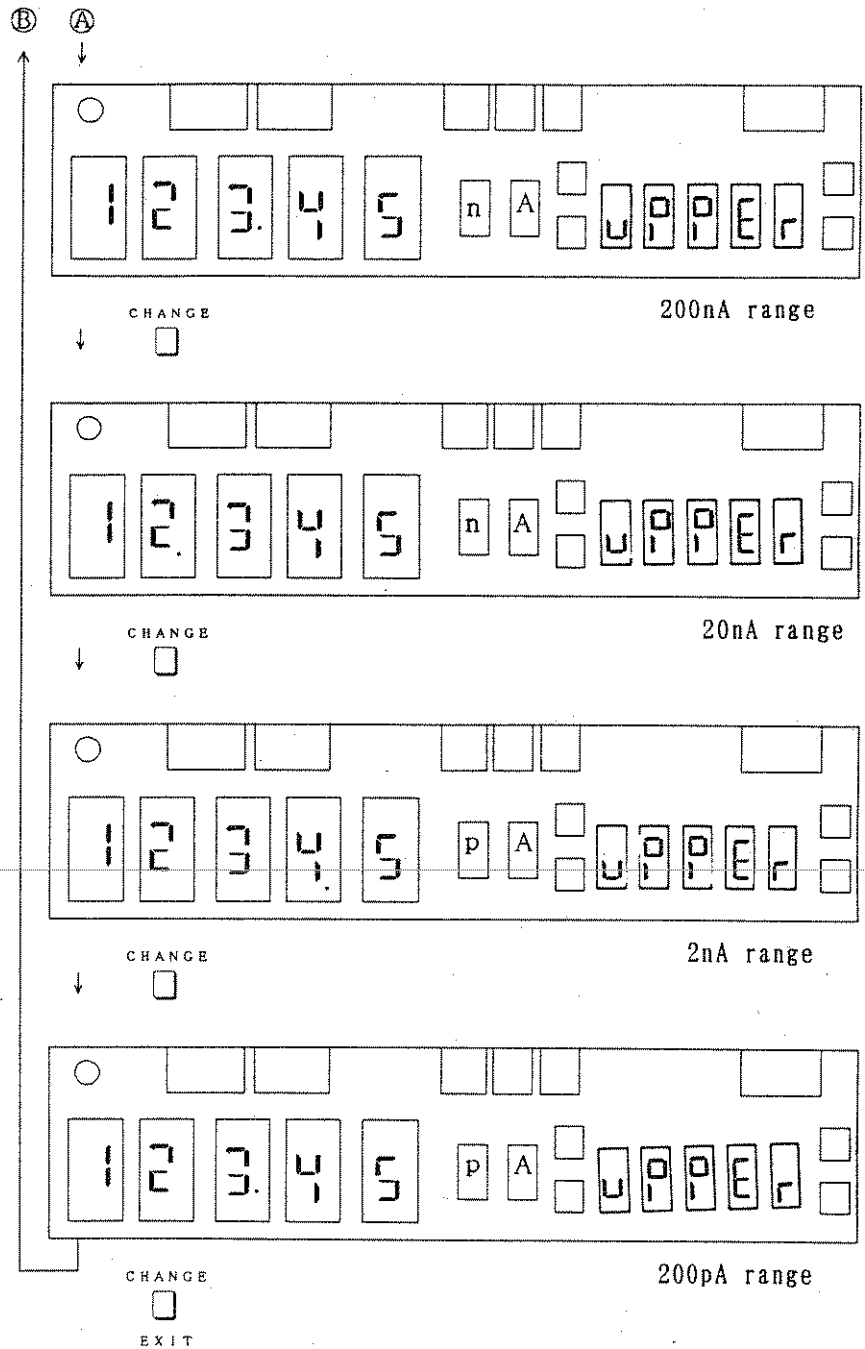

- ③ When the  is pressed, the unit indication changes to symbol unit and the setting ends.

## (2) For Exponent Unit Indication

The symbol unit indication is described in Item (1). Also for the exponent unit indication, change the exponent value with

the  <sup>CHANGE</sup>.

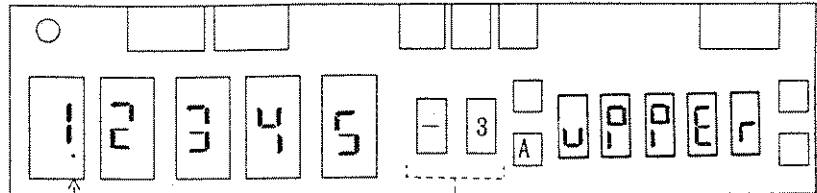

The decimal point position is fixed.

Change them with the

<sup>CHANGE</sup>.

## CAUTION

- The following shows the setting range of each measured value.

Current measured value :  
 -19.999mA ( $-1.9999 \times 10^{-2} \text{A}$ ) to  
 19.999mA ( $1.9999 \times 10^{-2} \text{A}$ )

Resistance measured value:  
 000.0m  $\Omega$  ( $0.000 \times 10^{-1} \Omega$ ) to  
 30.00E $\Omega$  ( $3.000 \times 10^{10} \Omega$ )

Volume resistivity :  $0.000 \times 10^{-6} \Omega$  to  $3.000 \times 10^{24} \Omega$

Surface resistivity :  $0.000 \times 10^{-4} \Omega$  to  $3.000 \times 10^{20} \Omega$

If a value exceeding the above range is set, an input

error occurs when pressing the  <sup>EXIT</sup> or the  <sup>CHANGE</sup>.

- Be sure to set the upper-level and lower-level values so that they will meet the following inequality.  
 Upper level value  $\geq$  Lower level value
- If an upper-level set value smaller than a lower-level set value is set, an input error occurs.

In this case, press the  <sup>COEF</sup> to move to the lower level setting state and set a lower-level value smaller than the upper level value.

- If you input an incorrect value, press the  <sub>CE</sub>. Then the preceding set value appears and you can input a new value.

## 4.4.2 LOWER Level

The following describes how to set lower level for comparison in the COMPARE mode.

(1) For Symbol Unit Indication

Operation (① through ③)

- ① Press the <sup>COEF</sup>  twice, and the indication **LOWER** appears.  
The present lower-level set value is displayed.

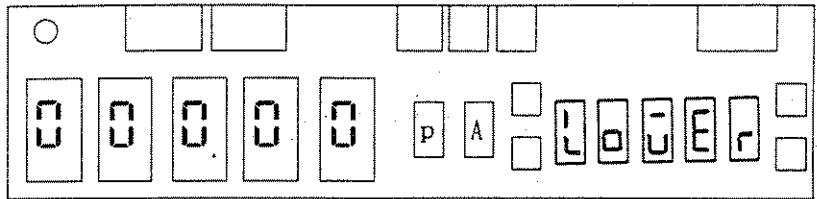

Present set value

- ② To change the present set value, input a new value with numeric keys. To change the setting to -123.45, for example:

- ②-1 Input numeric values as follows:  
Press the      and   
+/- 1 2 3 4 5

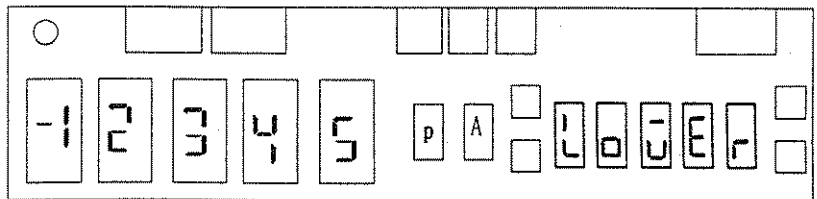

②-2 Set the range.

Press the <sup>CHANGE</sup>  until the required range appears.

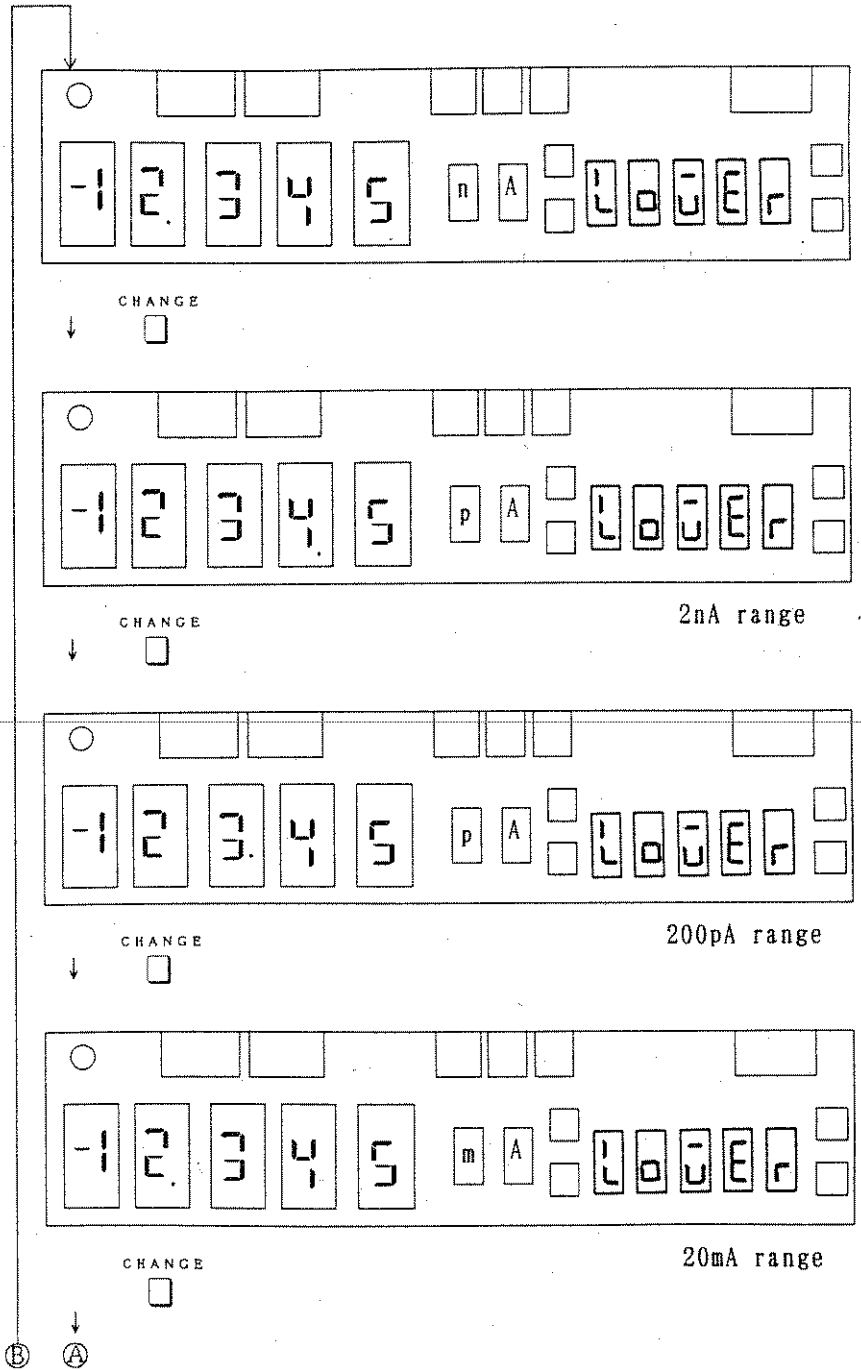

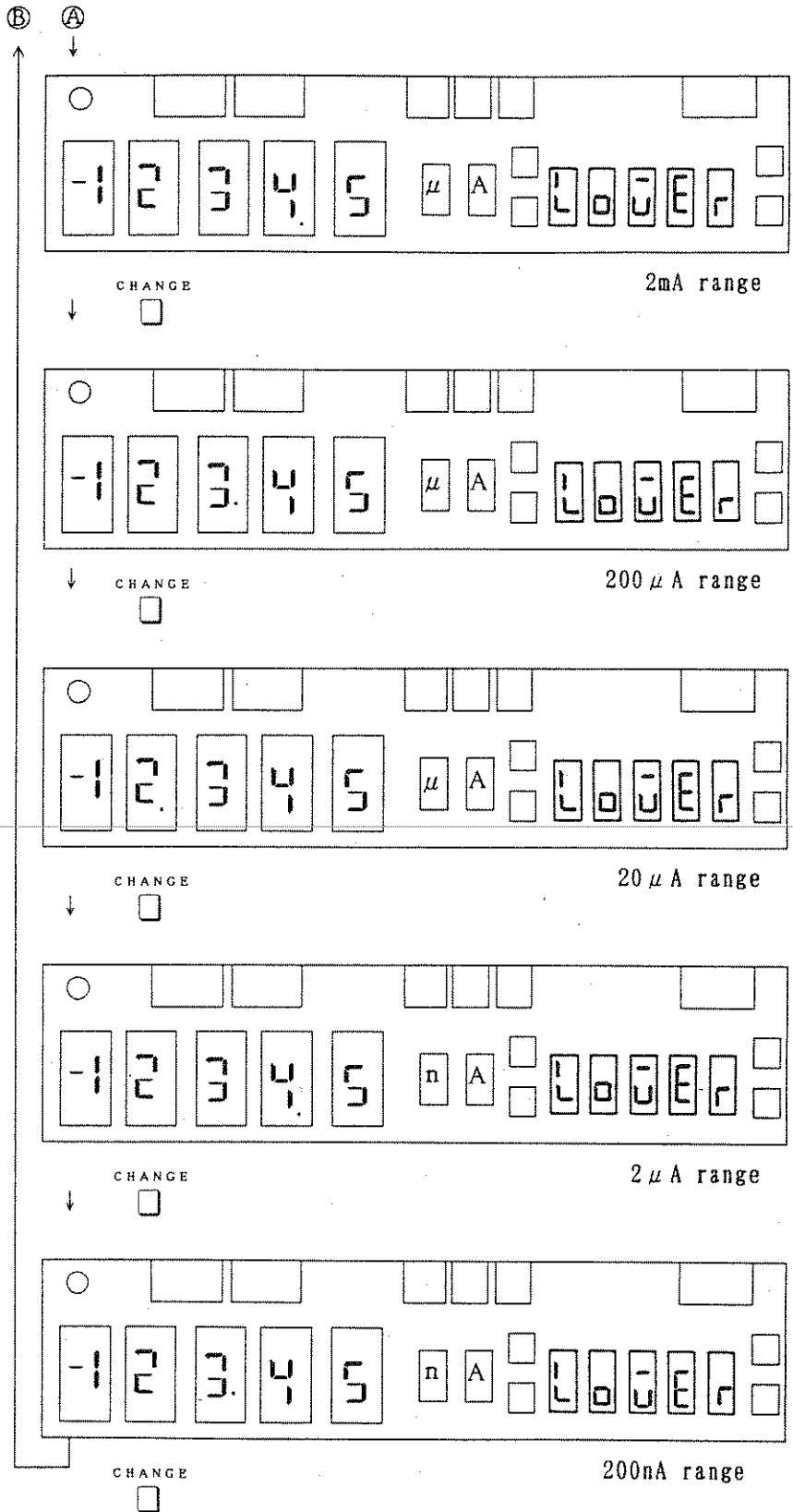

- ③ When the <sup>EXIT</sup>  is pressed, the unit indication changes to symbol unit and the setting ends.

(2) For Exponent Indication

The symbol unit indication is described in Item (1). Also for the exponent unit indication, change the exponent value with

the <sup>CHANGE</sup> .

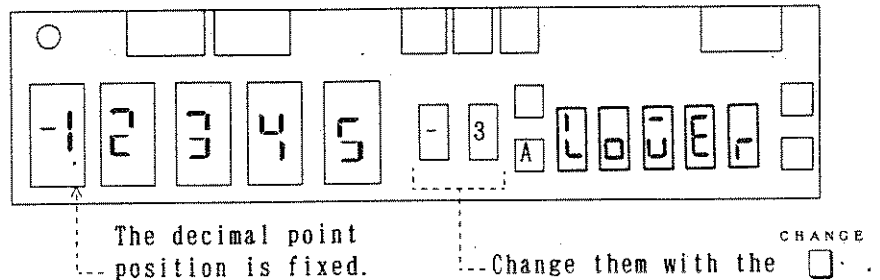

CAUTION

- The following shows the setting range of each measured value.

Current measured value:

-19.999mA ( $-1.9999 \times 10^{-2}$ A) to  
19.999mA ( $1.9999 \times 10^{-2}$ A)

Resistance measured value:

000.0m $\Omega$  ( $0.000 \times 10^{-1}$  $\Omega$ ) to  
30.00E $\Omega$  ( $3.000 \times 10^{10}$  $\Omega$ )

Volume resistivity :  $0.000 \times 10^{-6}$  $\Omega$  to  $3.000 \times 10^{24}$  $\Omega$

Surface resistivity:  $0.000 \times 10^{-4}$  $\Omega$  to  $3.000 \times 10^{20}$  $\Omega$

If a value exceeding the above range is set, an input

error occurs when pressing the <sup>EXIT</sup>  or the <sup>CHANGE</sup> .

- Be sure to set the upper-level and lower-level values so that they will meet the following inequality.  
Upper level value  $\geq$  Lower level value
- If an lower-level set value larger than a upper-level set value is set, an input error occurs.  
In this case, re-input the correct value.

### 4.4.3 Resistance Measurement Indication

In the resistance measurement state; the resistance-value, volume resistivity, or surface resistivity indication is set. The following describes how to set resistance measurement indication.

Operation (① through ③)

- ① Press the <sup>COEF</sup>  three times, and the indication  $\rho$   $\bar{n}$  appears.
- ② Press the <sup>CHANGE</sup>  until the required indication appears.

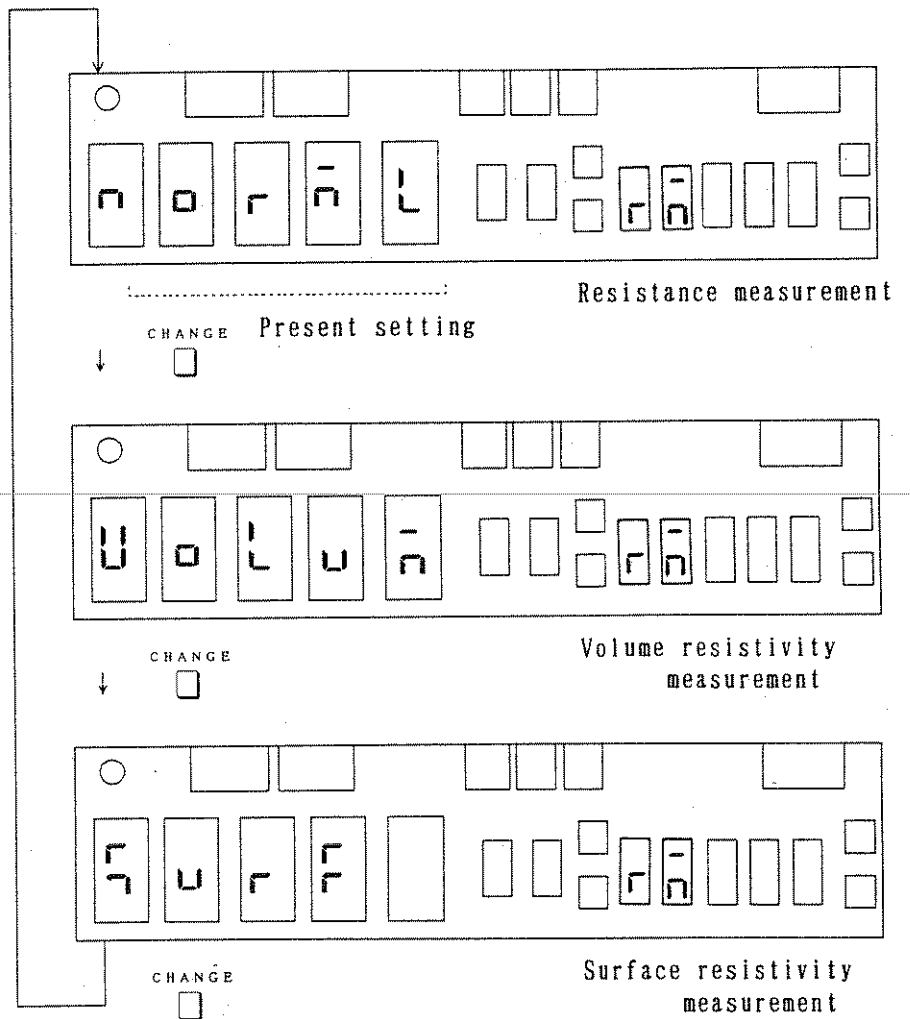

- ③ When the <sup>EXIT</sup>  is pressed, the setting ends.



#### 4.4.4 Setting of Volume- / Surface-Resistivity Electrode

The following describes how to set electrode used for measurement of volume and surface resistivities.

Operation (① through ③)

- ① Press the <sup>COEF</sup>  four times, and the indication

E. 0 1 n̄ appears.

- ② Press the <sup>CHANGE</sup>  until the required electrode appears.

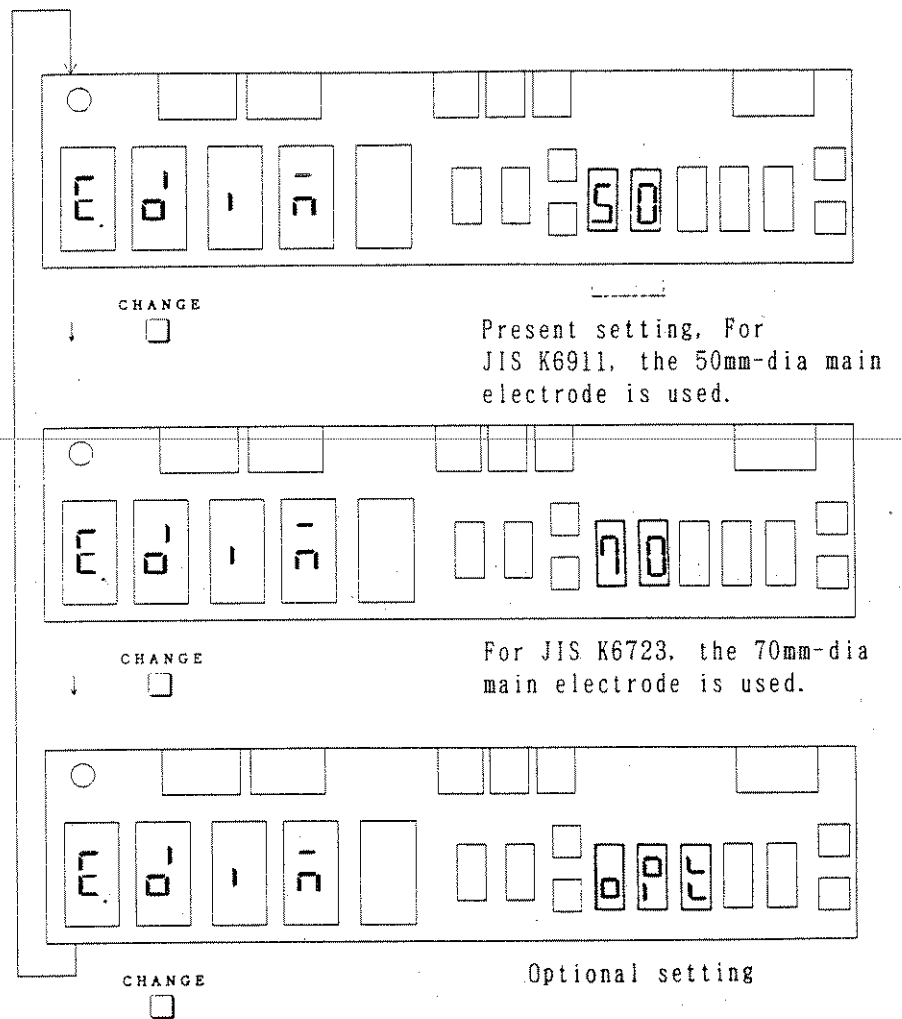

- ③ When the <sup>EXIT</sup>  is pressed, the setting ends.

## 4.4.5 Optional Electrode Coefficient

The following describes how to set electrode coefficient for optional setting in Item 4.4.4 "Setting of volume-/surface resistivity electrode".

Operation (① through ④)

① Press the  <sup>COEF</sup> five times, and the indication  
 U. C O E F or S. C O E F appears.

② Press the  <sup>CHANGE</sup> to set a volume or surface resistivity.  
 Whenever the  <sup>CHANGE</sup> is pressed, the setting is changed over.

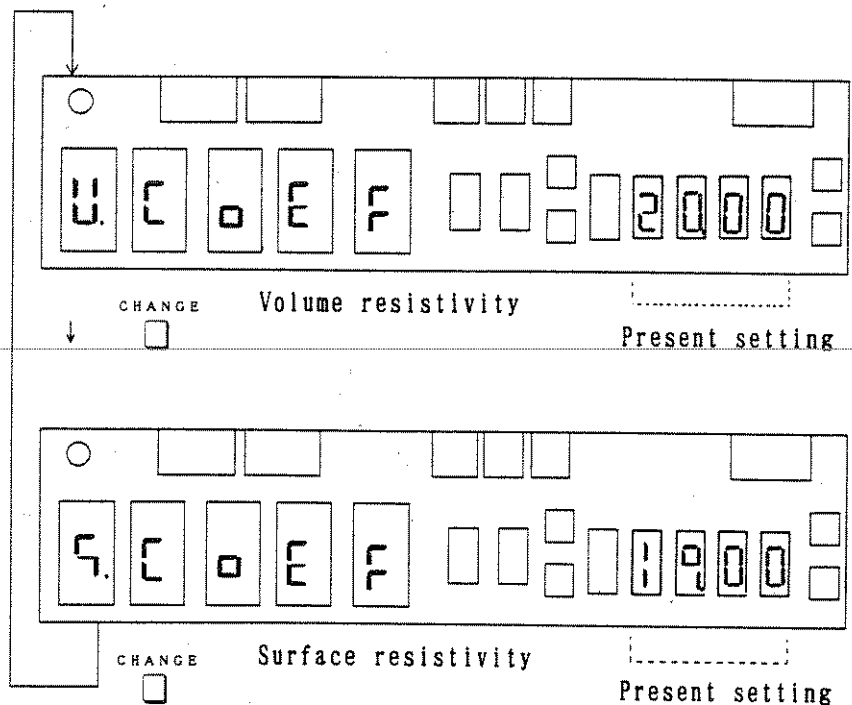

③ Input an electrode coefficient value.

③-1 For Volume Resistivity

To change the setting to "34.56", for example:

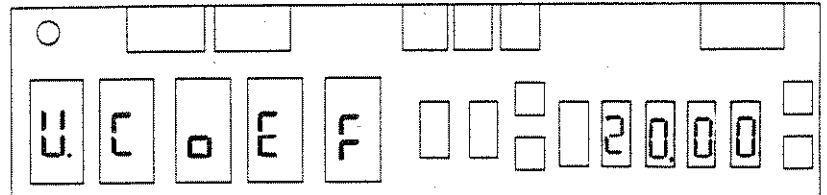

Present setting

↓ Press the  <sub>3</sub>  <sub>4</sub>  <sub>5</sub> and  <sub>8</sub>.

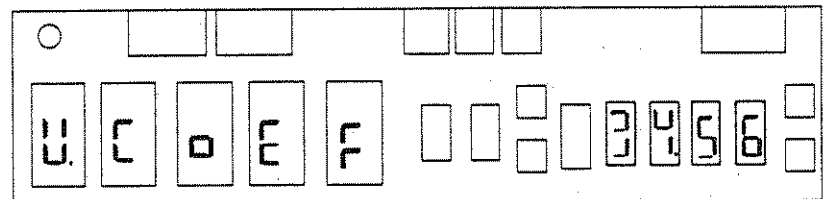

③-2 For Surface Resistivity

To change the setting to "23.45", for example:

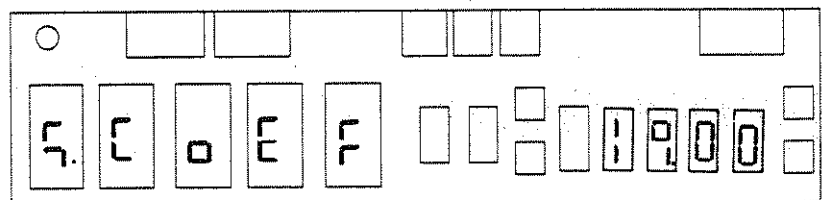

Present setting

↓ Press the  <sub>2</sub>  <sub>3</sub>  <sub>4</sub> and  <sub>5</sub>.

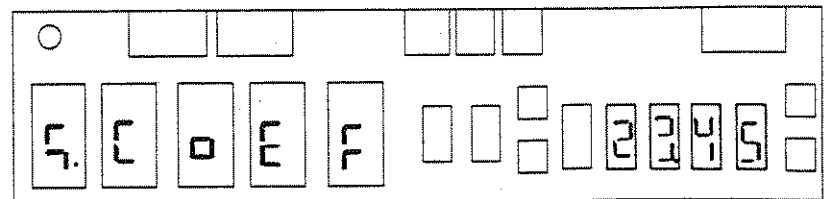

④ When the  <sup>EXIT</sup> is pressed, the setting ends.

## CAUTION

1. The coefficient setting range is 0.001 through 9999. If a value out of the range is set, an input error occurs when the <sup>EXIT</sup>  is pressed.
2. The electrode coefficient for either volume or surface resistivity can be set.
3. If you input an incorrect value, press the  <sub>CE</sub>. Then the preceding set value appears and you can input a new value.

## 4.4.6 Sample Thickness

The following describes how to set sample thickness necessary for measurement of volume resistivity. The sample thickness unit uses "mm".

Operation (① through ③)

- ① Press the <sup>COEF</sup>  six times, and the indication

S A M P L appears.

- ② Input the sample thickness value. To change the setting to "12.34 mm", for example:

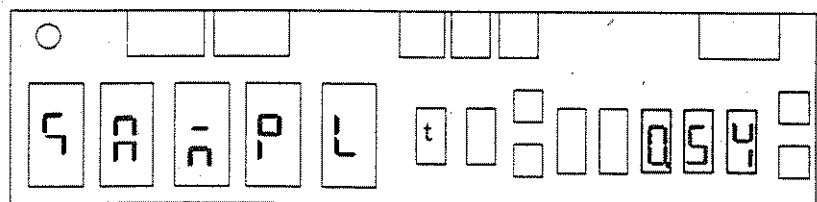

↓ Press the  <sub>1</sub>  <sub>2</sub>  <sub>3</sub> and  <sub>4</sub>. Present setting

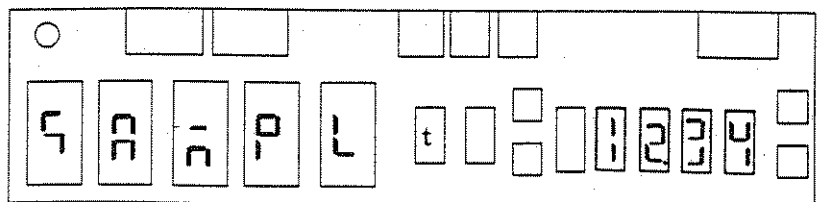

- ③ When the <sup>EXIT</sup>  is pressed, the setting ends.

## CAUTION

1. The sample thickness setting range is 0.001 through 999.9. If a value out of the range is set, an input error occurs when the <sup>EXIT</sup>  is pressed.
2. If you input an incorrect value, press the . Then the preceding set value appears and you can input a new value.

## 4.4.7 Contact Level

For the description of contact level, see Item 3.3.8 "Contact checking". The following describes how to set contact level.

Operation (① through ③)

- ① Press the <sup>COEF</sup>  seven times, and the indication appears.

- ② Press the <sup>CHANGE</sup>  until the required contact level appears.

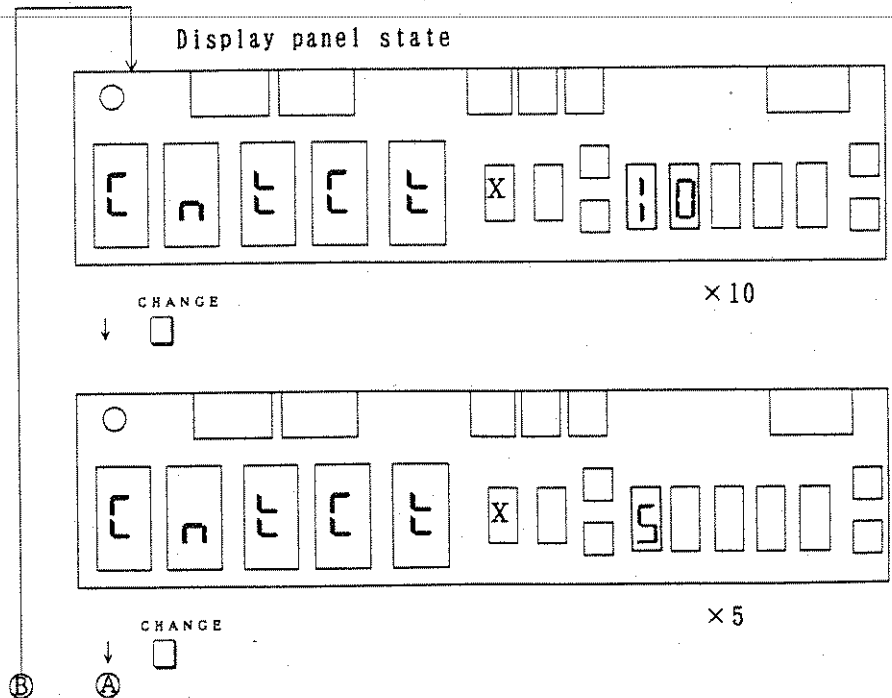

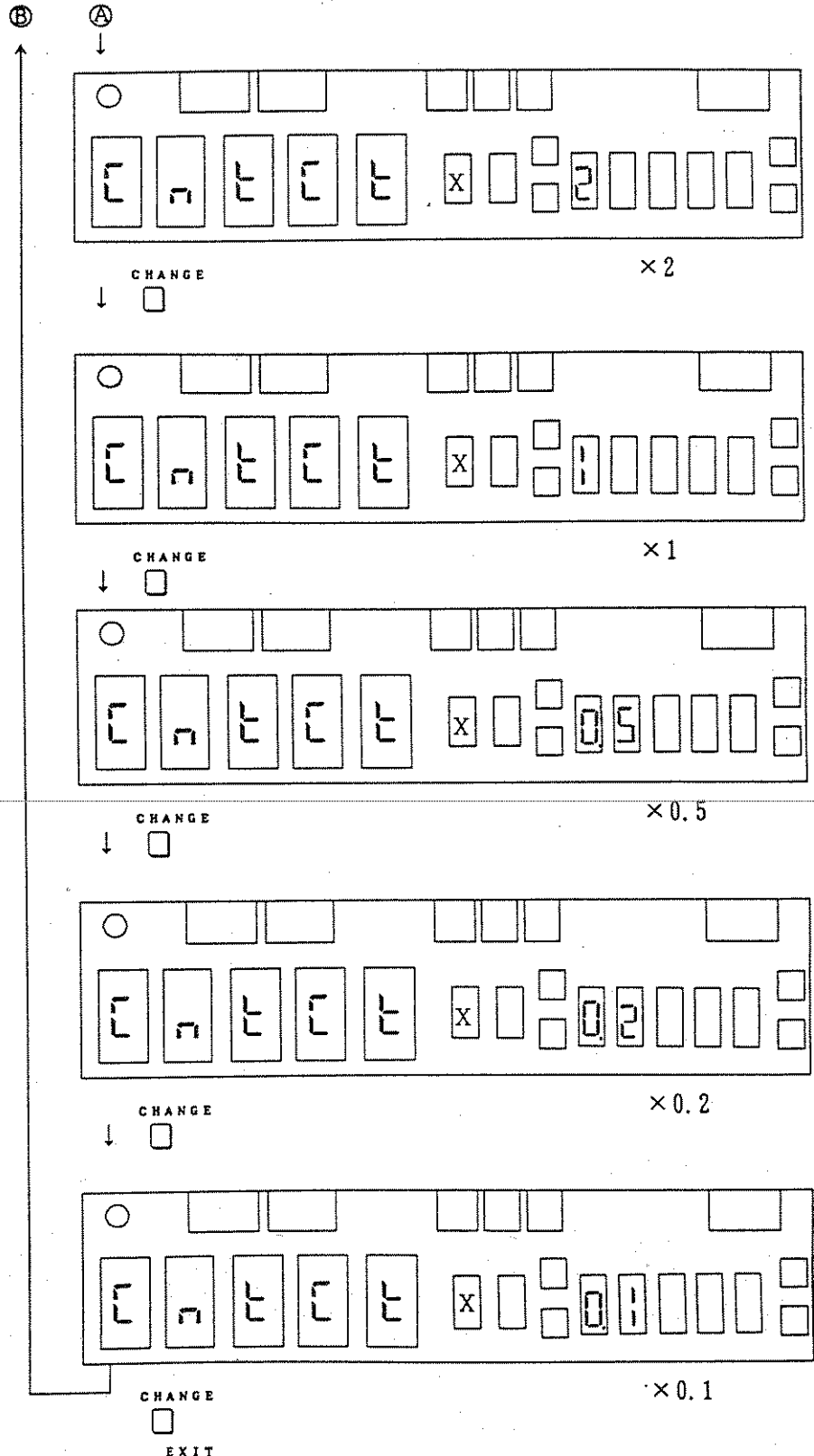

③ When the  is pressed, the setting ends.

## 4.4.8 Buzzer

When the buzzer is set to ON, it sounds in a high-pitched or low-pitched tone under the following conditions.

- COMPARE operation results HI:High-pitched tone  
LO:Low-pitched tone
- Fuse open :High-pitched tone
- Overheat detection :High-pitched tone
- Circuit failure :High-pitched tone
- Various errors :Low-pitched tone

The following describes how to set buzzer function.

Operation (① through ③)

- ① Press the <sup>COEF</sup>  eight times, and the indication B Z appears.
- ② Press the <sup>CHANGE</sup>  to set the buzzer to ON or OFF. Whenever the <sup>CHANGE</sup>  is pressed, the setting is changed over.

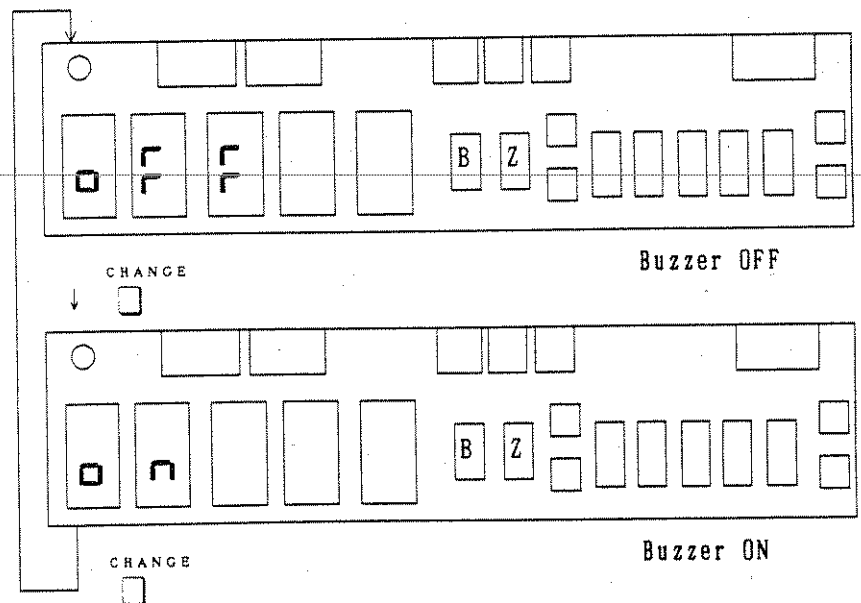

- ③ When the <sup>EXIT</sup>  is pressed, the setting ends.

## 4.4.9 Data Indicator

When the indicator is set to OFF, measurement cycle is quickened because no measured data is output to the indicator. Under the OFF state, however, the decimal point and unit of measured values are displayed. The following describes how to set data indicator to ON or OFF.

Operation (① through ③)

- ① Press the <sup>COEF</sup>  nine times, and the indication

appears.

- ② Press the <sup>CHANGE</sup>  to set the indicator to ON or OFF.

Whenever the <sup>CHANGE</sup>  is pressed, the setting is changed over.

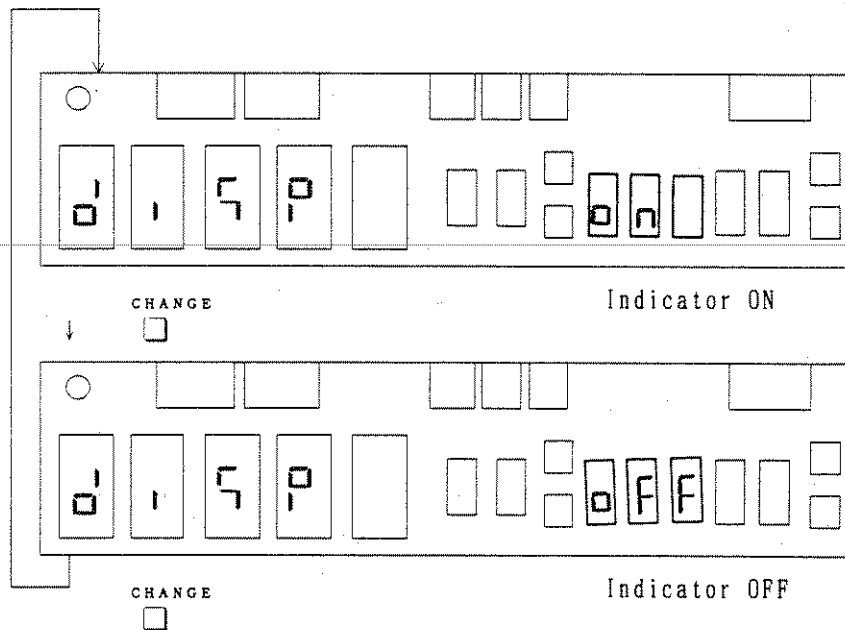

- ③ When the <sup>EXIT</sup>  is pressed, the setting ends.



#### 4.4.10 Contact Initial Integral Time

The noise may cause the measurement data unstable in the contact check and contact initial. This time, reset the contact initial integral time.

Integral time ——— 2ms : Set this value when the noise is low and the integration speed is high to do a correct judgment.  
 ——— 1PLC: Set this value when there are much noises.

In the contact check and contact initial, since the measured data is not displayed, check the noise level by measuring the current described below and determine the contact initial integral time.

- (1) Connect the test piece to the measuring device and set the current range to 20 nA.
- (2) Set the gain to x10000 and select the measurement condition and free run condition.
- (3) Check the dispersions of the current measured when the integrate time (IT) is set to 2ms or 1PLC and compare the contact initial integral times with them in Table 4-3.

Table 4-3 Setting Contact Initial Integral Time Per Noise Level

Integral Time (IT)	Dispersion of current measured	Setting contact initial integral time
2ms	Less than 10 counts	2mS, 1PLC
	More than 10 counts	1PLC
1PLC	Less than 100 counts	
	More than 100 counts	

#### CAUTION

1. If you reset the contact initial integral time, execute the contact initial. The contact check integration time is determined by the contact initial integral time.
2. If the dispersion of current measured exceeds 100 counts when 1PLC is set (Table 4-3), the contact check will be unstable. Perform shielding so that the dispersion should be less than 100 counts.

The following describes how to set contact initial integration time.

Operation ( ① through ③ )

- ① Press the <sup>COEF</sup>  ten times, and the indication

[ n t . , t ] appears.

- ② Press the <sup>CHANGE</sup>  until the required integration time appears.

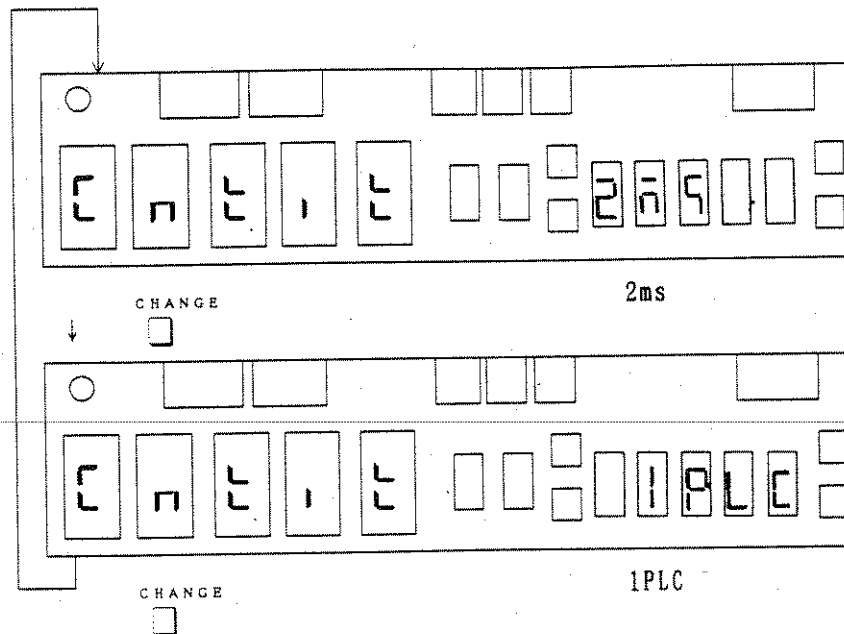

- ③ When the <sup>EXIT</sup>  is pressed, the setting ends.

## 4.5 Various I/O-key Setting Methods

### 4.5.1 DA OUTPUT (R8340A Only)

This function is not given to the R8340. The following describes how to set D/A output to ON (selection of number of digits) or OFF.

Operation (① through ③)

- ① Press the  <sup>I/O</sup> once, and the indication

0 1 0 0 0 appears.

- ② Press the  <sup>CHANGE</sup> to set D/A output to the required number of digits or OFF. Whenever the  <sup>CHANGE</sup> is pressed, the setting is changed over.

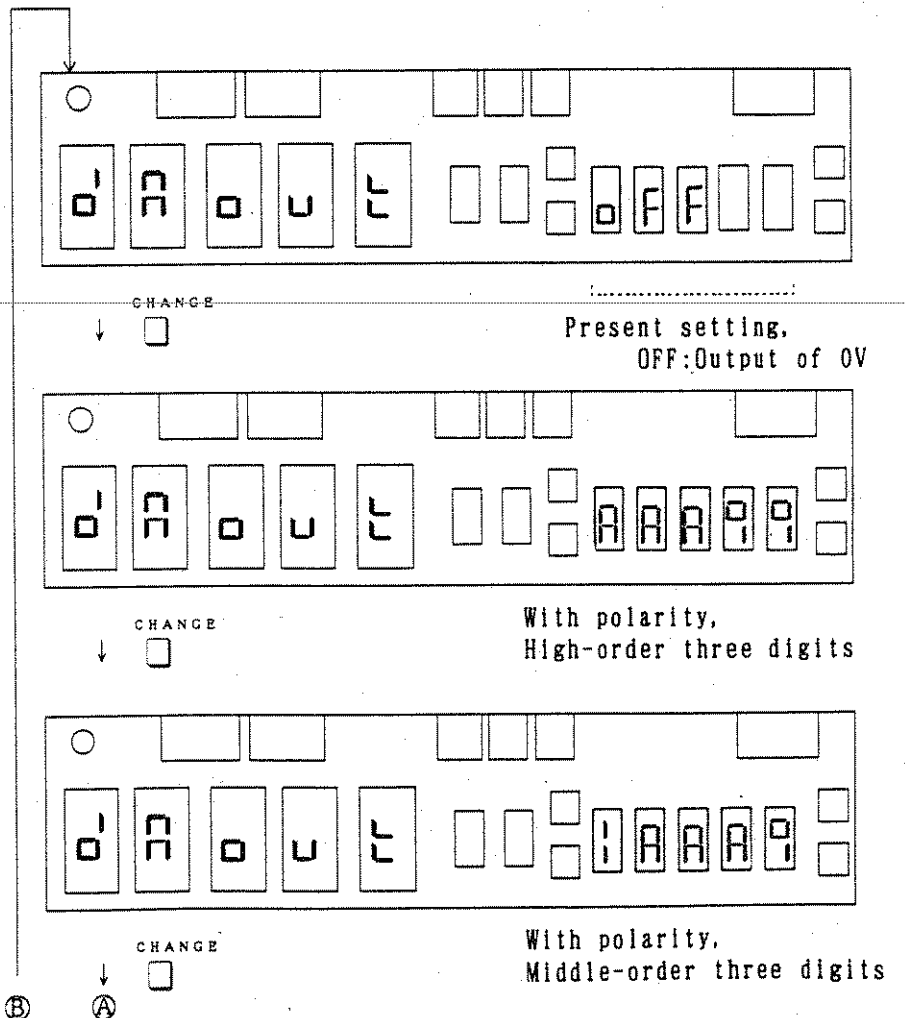

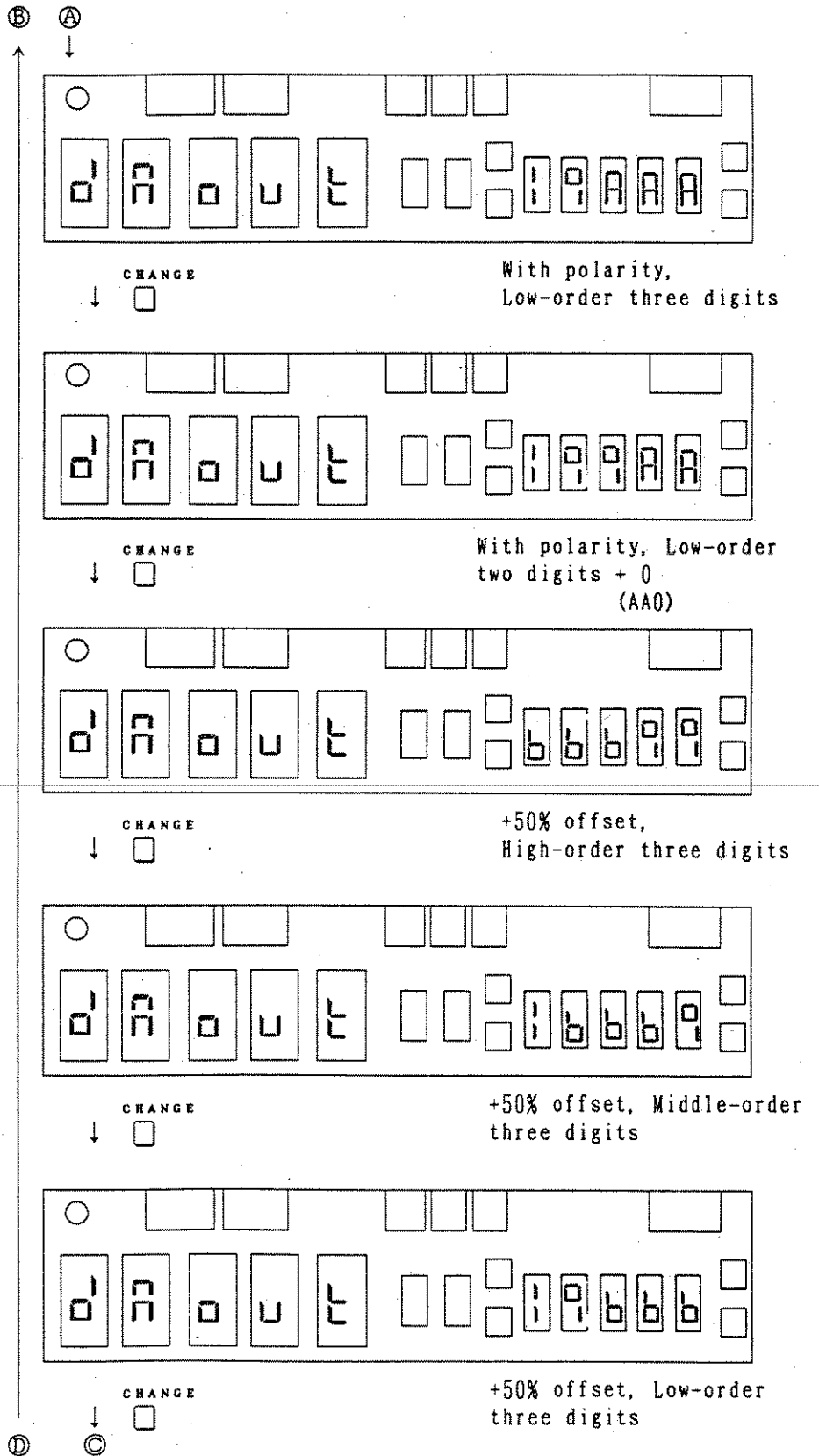

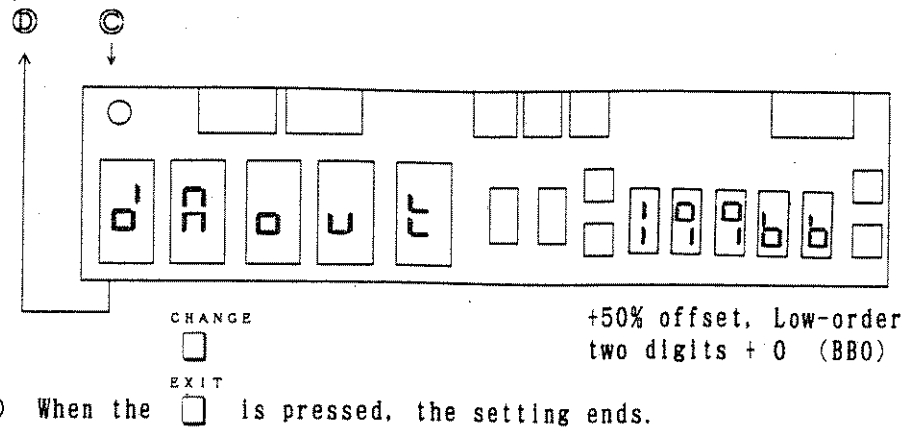

### 4.5.2 BCD OUTPUT (R 8 3 4 0 A Only)

This function is not given to the R8340. The following describes how to set the BCD OUTPUT terminal on the rear panel of R8340A to OFF (all high), BCD, or binary output.

Operation (① through ③)

- ① Press the  twice, and the indication '0 C 0' appears.
- ② Press the  until the required output appears.

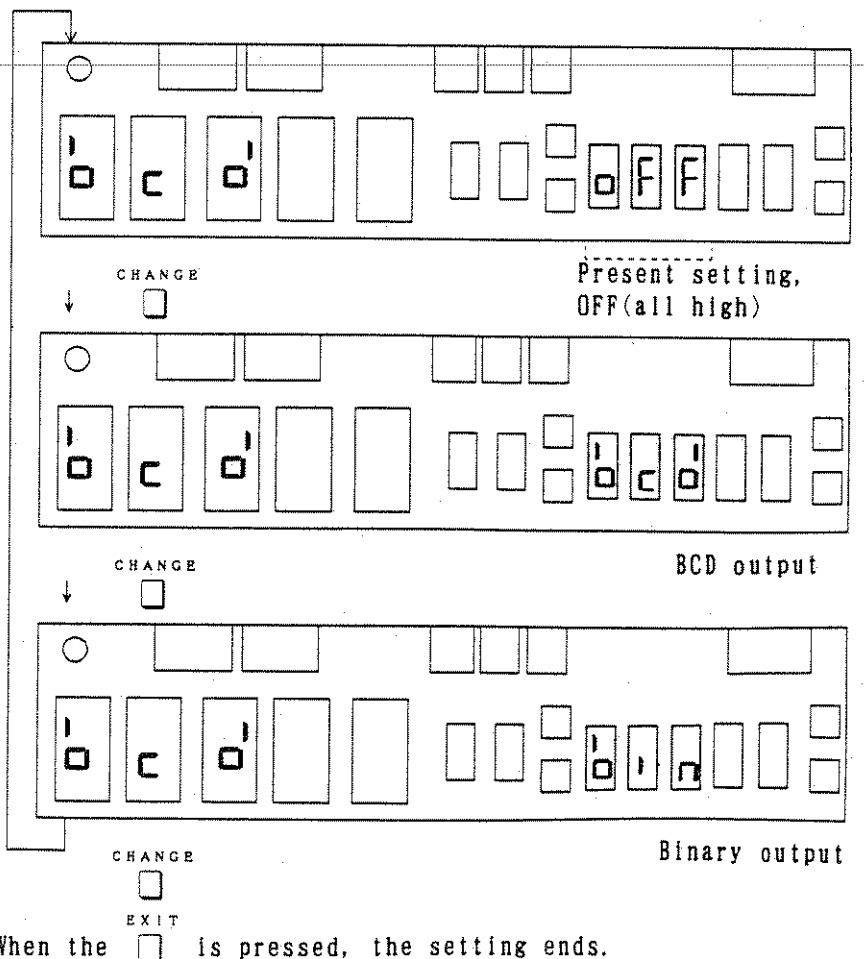

4.5.3 GPIB

The following describes how to set GPIB header to ON or OFF and how to set address.

Operation (① through ④)

- ① Press the  <sup>I/O</sup> three times, and the indication

G P - I b appears.

- ② Header setting

Press the  <sup>CHANGE</sup> until the required header appears.

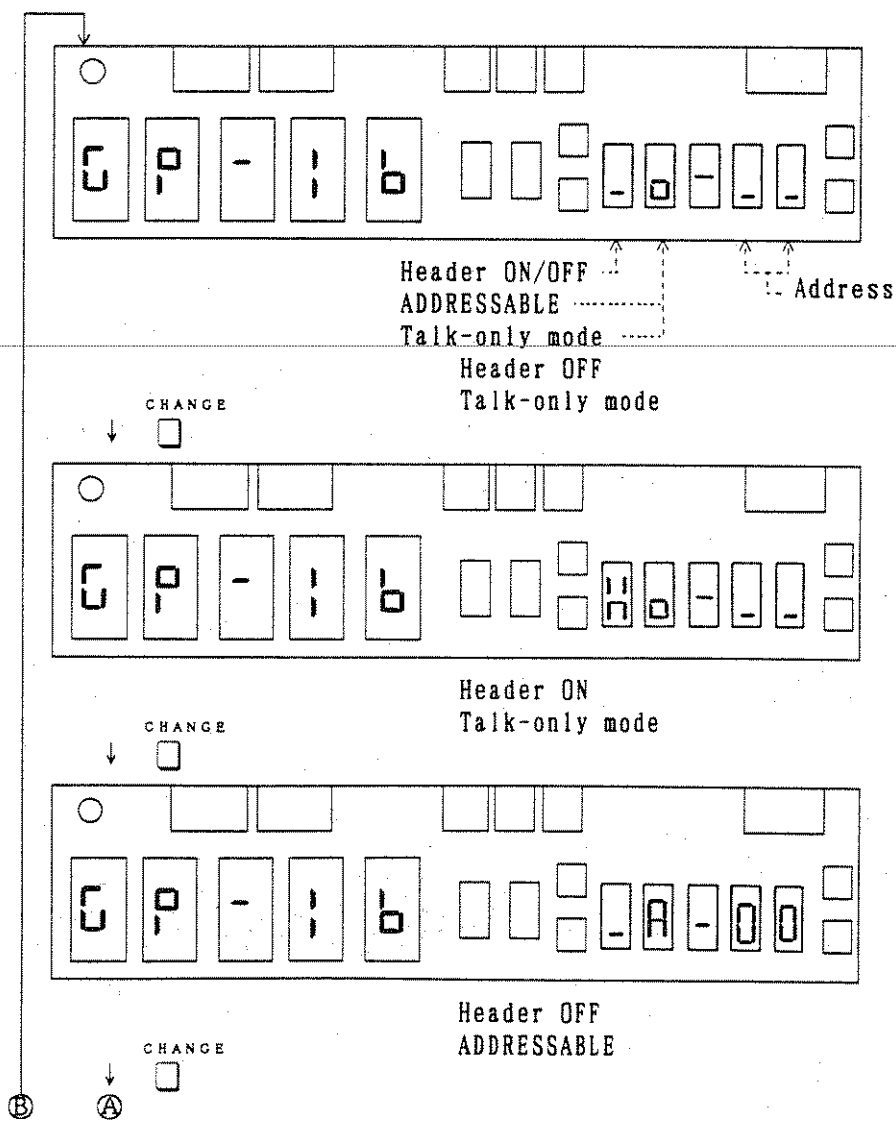

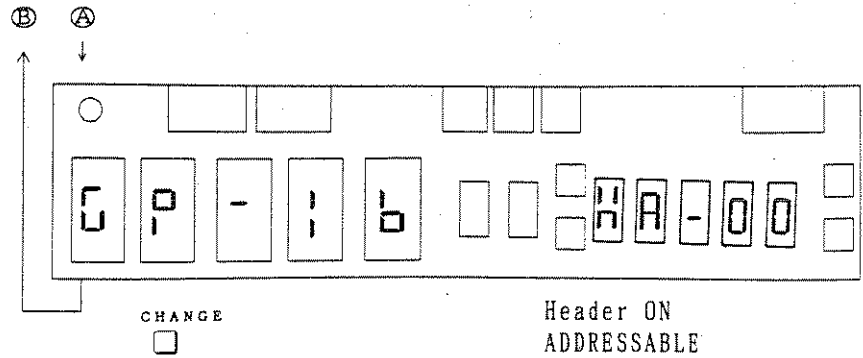

- ③ Address Setting  
To set the address to 15, for example:

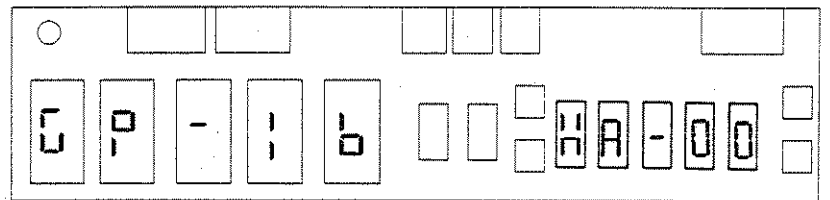

↓ Press the <sub>1</sub> and <sub>5</sub>.

Present address

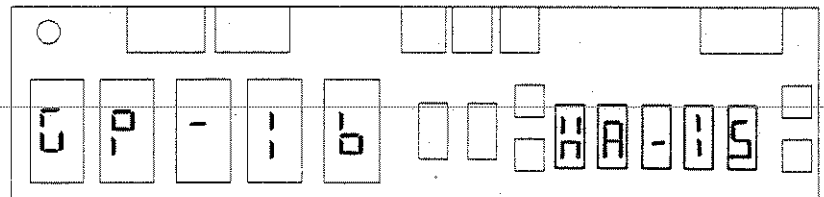

- ④ When the <sup>EXIT</sup> is pressed, header ON/OFF and address setting end.

#### CAUTION

1. If the address is set to 31 or more, an error occurs.
2. No address can be set in the talk-only mode.
3. When the talk-only mode is set, data can directly be output to a listener such as a printer without any controller. In this case, also set the listener to the talk-only mode but do not operate the controller at the same time.

## 4.5.4 Power Frequency

The following describes how to set power frequency to 50 or 60 Hz.

Operation (① through ③)

- ① Press the  <sup>I/O</sup> four times, and the indication

L I n E F appears.

- ② Press the  <sup>CHANGE</sup> to set the frequency to 50 or 60 Hz.

Whenever the  <sup>CHANGE</sup> is pressed, the setting is changed over.

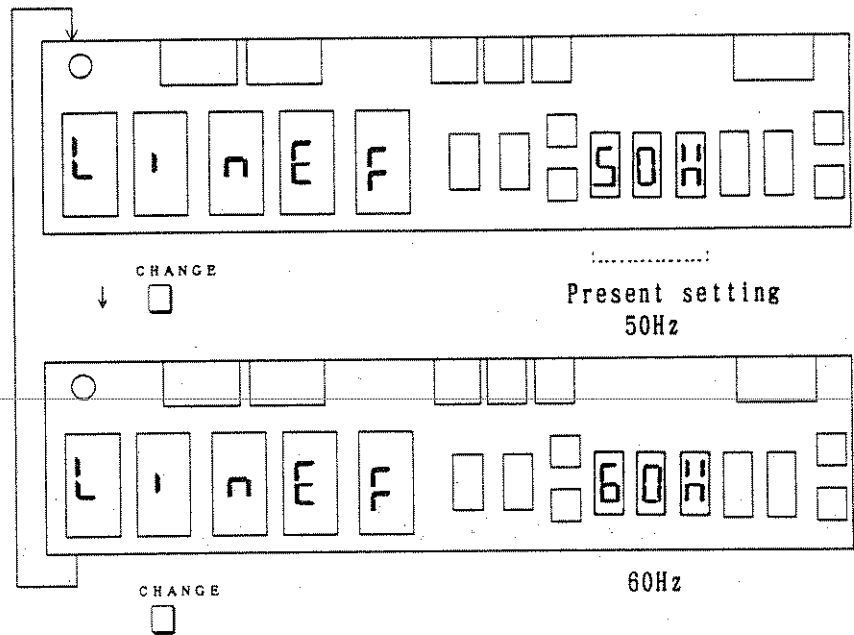

- ③ When the  <sup>EXIT</sup> is pressed, the setting ends.



## 4.6 Various MEM-key Setting Methods

### 4.6.1 Data Storage

Data storage is the function to store measured data in the internal memory. Up to 1000 data values can be stored. When the data storage is executed, data is stored every sample in order and the stored data is provided with a data number respectively. The following describes how to set data storage function to ON or OFF.

Operation (① through ③)

- ① Press the  <sup>MEM</sup> once, and the indication **S t o r E** appears.
- ② Press the  <sup>CHANGE</sup> to set the function to ON or OFF.  
Whenever the  <sup>CHANGE</sup> is pressed, the setting is changed over.

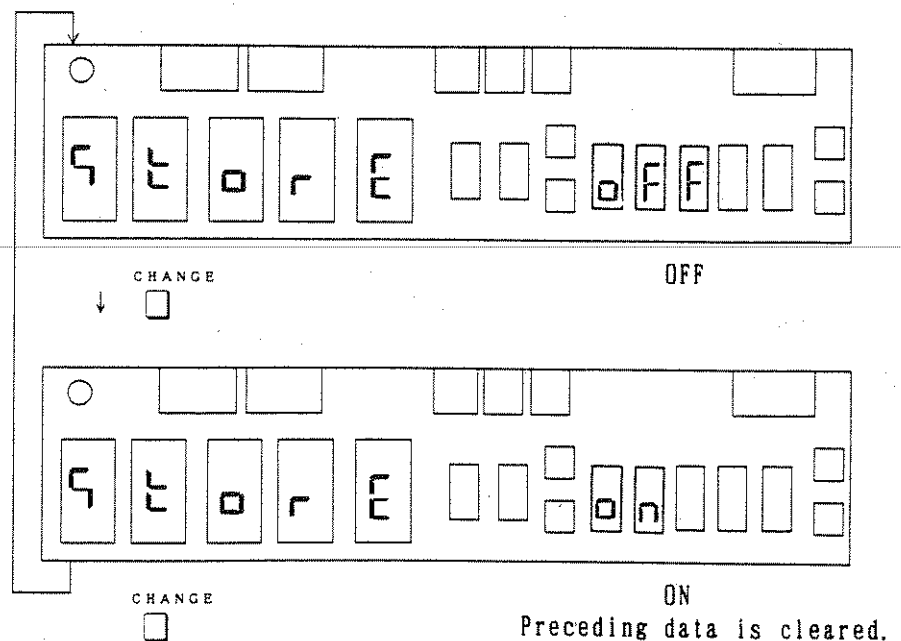

③ To end the setting or store data:

③-1 Press the  <sup>EXIT</sup>, and the setting ends.

③-2 When the function is set to ON, the following data storage operation is executed.

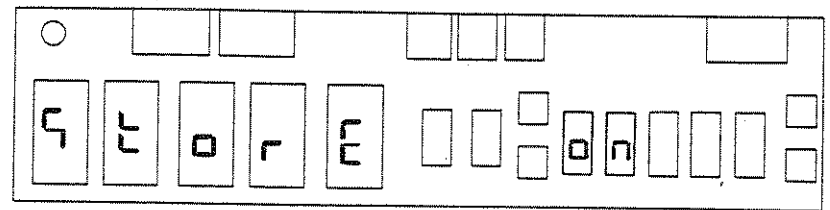

EXIT

ON

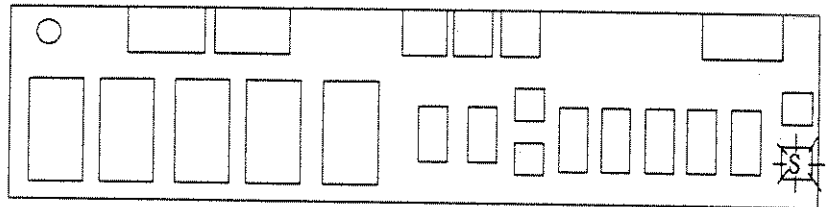

During execution of data storage (1000 data values are stored.) Flickering

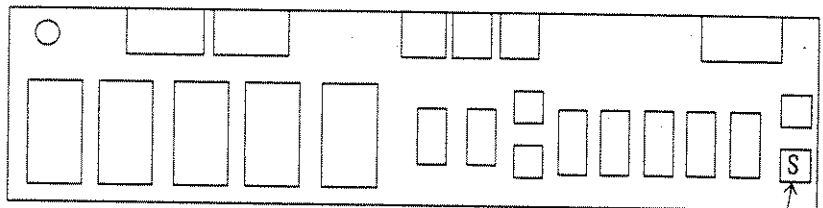

End of data storage

Lighting: Shows that stored data is present.

CAUTION

1. When data storage is executed, the operation ends after 1000 data values are stored. To end the operation before 1000 data values are stored, set the data storage function to OFF.
2. Stored data is deleted in the following cases.
  - When the power is turned off
  - When the data storage function is set to ON again

### 4.6.2 Data Recall

Data recall is the function to read measured data from the internal memory. The read method includes two types-continuous output and stepping output. The following describes the setting method. The continuous output is the method to read data one value by one value in order of the data number. The stepping output is the method to read required data among stored data one value by one value.

#### (1) Continuous Output

Operation (① through ③)

- ① Press the <sup>MEM</sup>  twice, and the indication

**R E C A L L** appears.

- ② Whenever the <sup>CHANGE</sup>  is pressed, data is output one value by one

value. When the <sup>CHANGE</sup>  is pressed again after the final data is displayed, return to the data number 1.

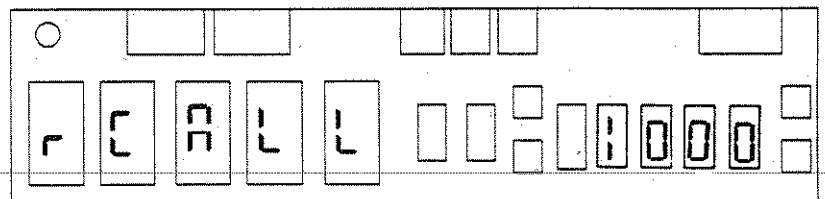

<sup>CHANGE</sup>

Number of stored data values

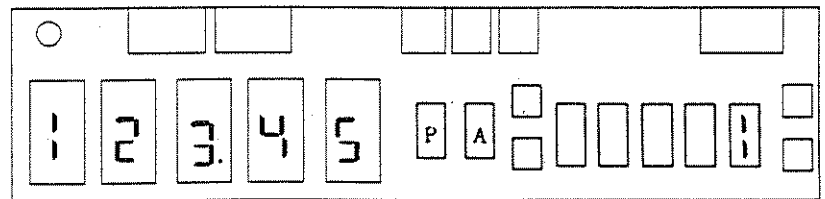

<sup>CHANGE</sup>   
<sup>CHANGE</sup>

Recall data

Data number

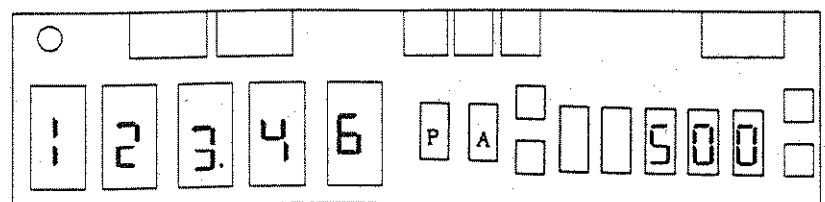

<sup>CHANGE</sup>   
Ⓐ

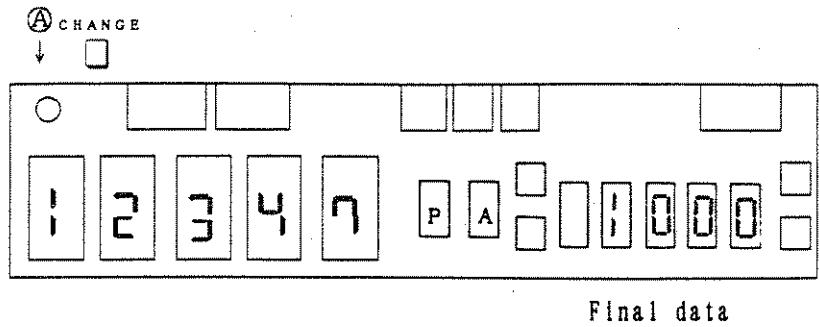

③ When the <sup>EXIT</sup>  is pressed, the state exits from the mode and returns to the normal measurement state.

(2) Stepping Output

Operation (① through ④)

- ① Press the <sup>MEM</sup>  twice.
- ② Press the <sup>CHANGE</sup>  to output data.

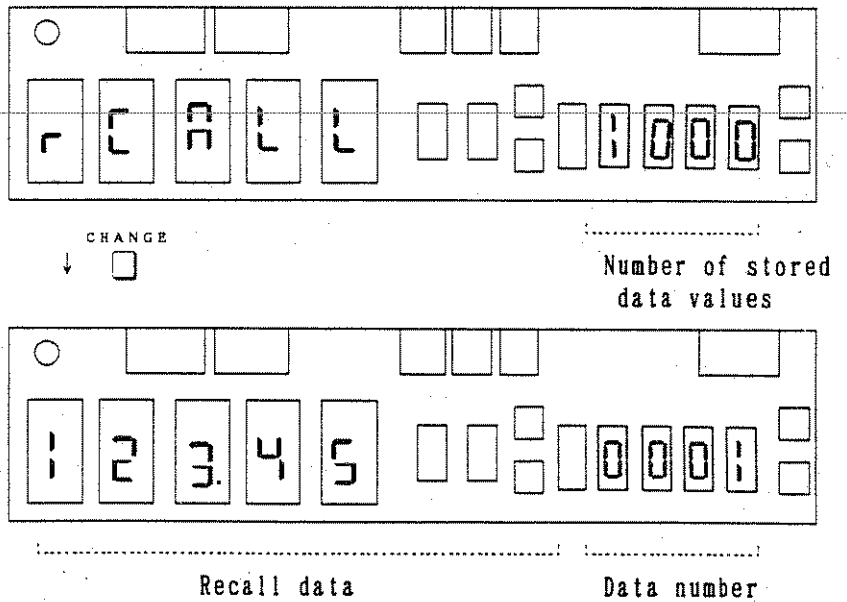

- ③ Input the data number to be recalled and press the  <sup>CHANGE</sup>.  
 To output the data No. 50, for example:

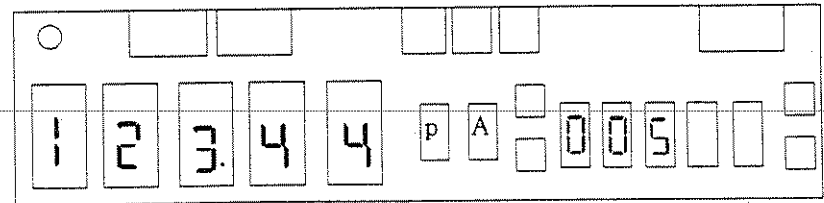
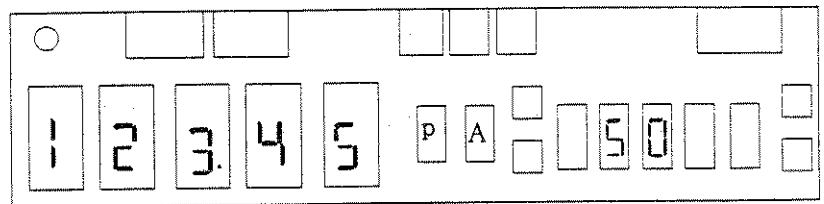
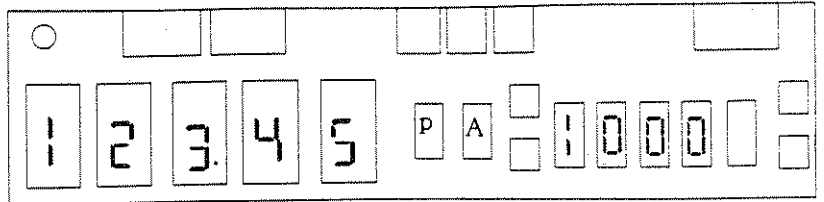

Indication of data No. 50

When the  <sup>CHANGE</sup> is pressed again, the continuous output mode is set and the next data is output. When a value is input again, the stepping output mode is set.

- ④ When the  <sup>EXIT</sup> is pressed, the state exits from the mode and returns to the normal measurement state.

## 5. SEQUENCE PROGRAM

This chapter describes the operation, execution methods and program parameter setting procedures of the sequence program.

Read "3. Operation Procedures" and "4. Parameter Key Description" before reading this chapter.

5.1 Sequence

Sequence program is the function to store the measuring conditions and procedure and execute the measurement under the same condition again by one touch operation. The measuring procedure has six types of sequences from No. 0 to No. 5. For the measuring conditions, it is possible to set the charge time, discharge time, measurement time and auto-start value to automatically judge the end of discharge. The function also makes it possible to measure the insulation resistance specified in JIS C5102 (Test Methods of Fixed Capacitors for Electronic Equipment) by setting the charge time to 1 min.

The following describes six types of sequences from the measuring procedure No.0 through No.5.

(1) Program No.0

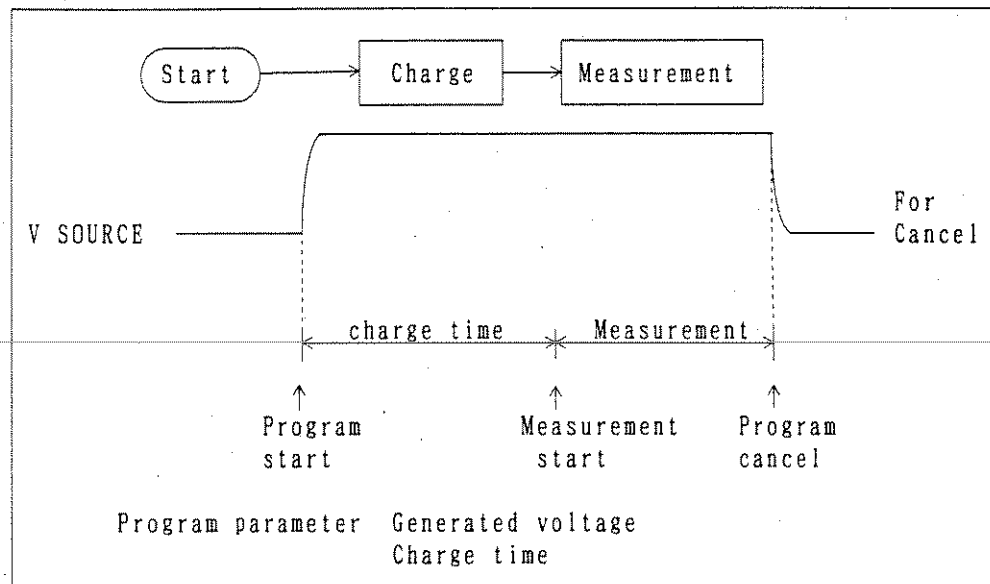

When the program No. 0 is started, charge is made, one-time measurement starts simultaneously with elapse of the charge time, and keep measuring in the measurement state until the program is canceled.

(2) Program No. 1

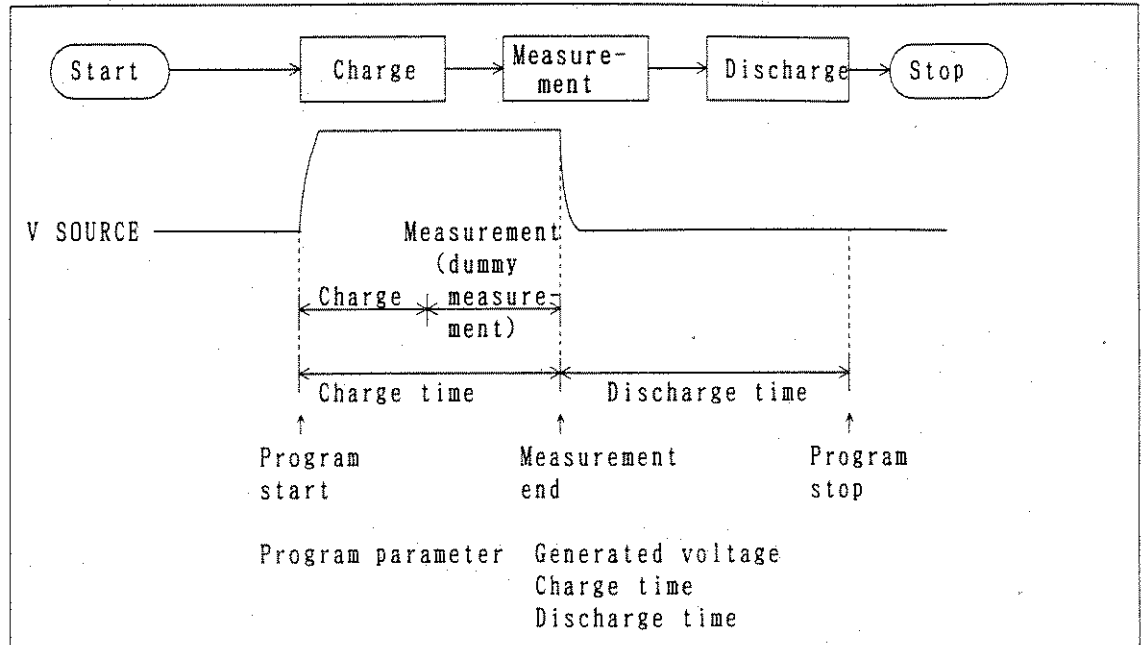

When the program No. 1 is started, charge is made and one-time measurement ends simultaneously with elapse of the charge time. When the measurement ends, the discharge state is set and the program ends.

CAUTION

1. For the charge time 2.001 seconds or more, the dummy measurement will be started at half time of the charge time.
2. For the charge time 2.000 seconds or less, the dummy measurement is not done.



## (3) Program No. 2

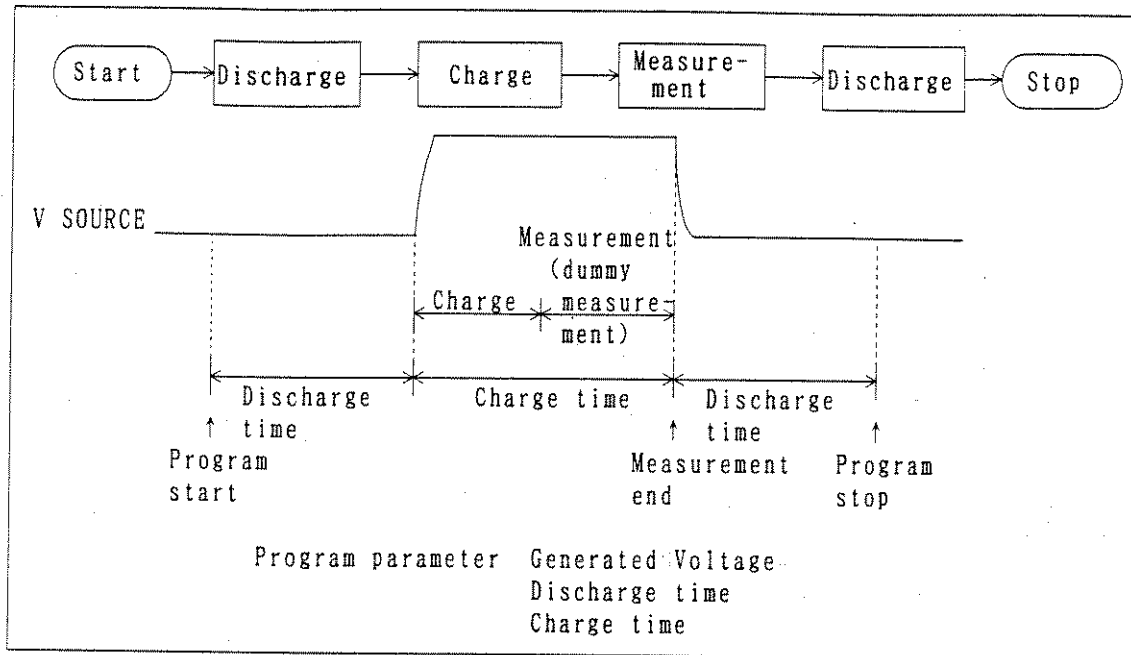

When the program No.2 is started, discharge is made and the charge state is set when the discharge time ends. One-time measurement ends simultaneously with elapse of the charge time, discharge is made, and the program ends.

## CAUTION

1. For the charge time 2.001 seconds or more, the dummy measurement will be started at half time of the charge time.
2. For the charge time 2.000 seconds or less, the dummy measurement is not done.

(4) Program No. 3

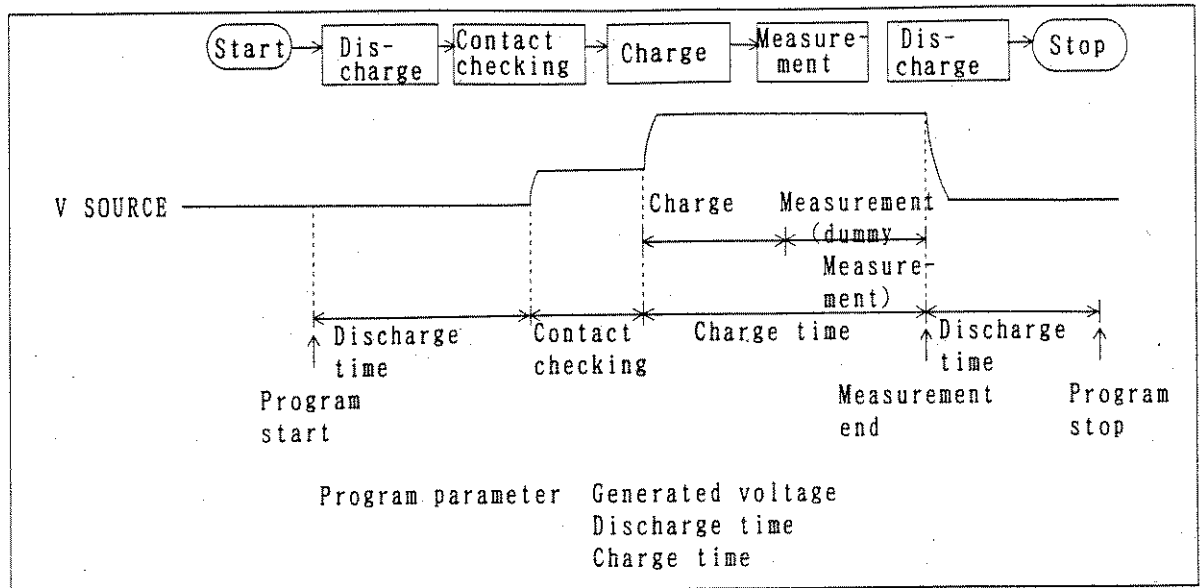

When the program No. 3 is started, discharge state is set and contact checking is made when the discharge time elapses. If contact checking is NG, the program ends immediately. When contact checking is OK; charge state is set, one-time measurement ends simultaneously with elapse of the charge time, discharge starts, and the program ends.

CAUTION

1. For the charge time 2.001 seconds or more, the dummy measurement will be started at half time of the charge time.
2. For the charge time 2.000 seconds or less, the dummy measurement is not done.

(5) Program No. 4

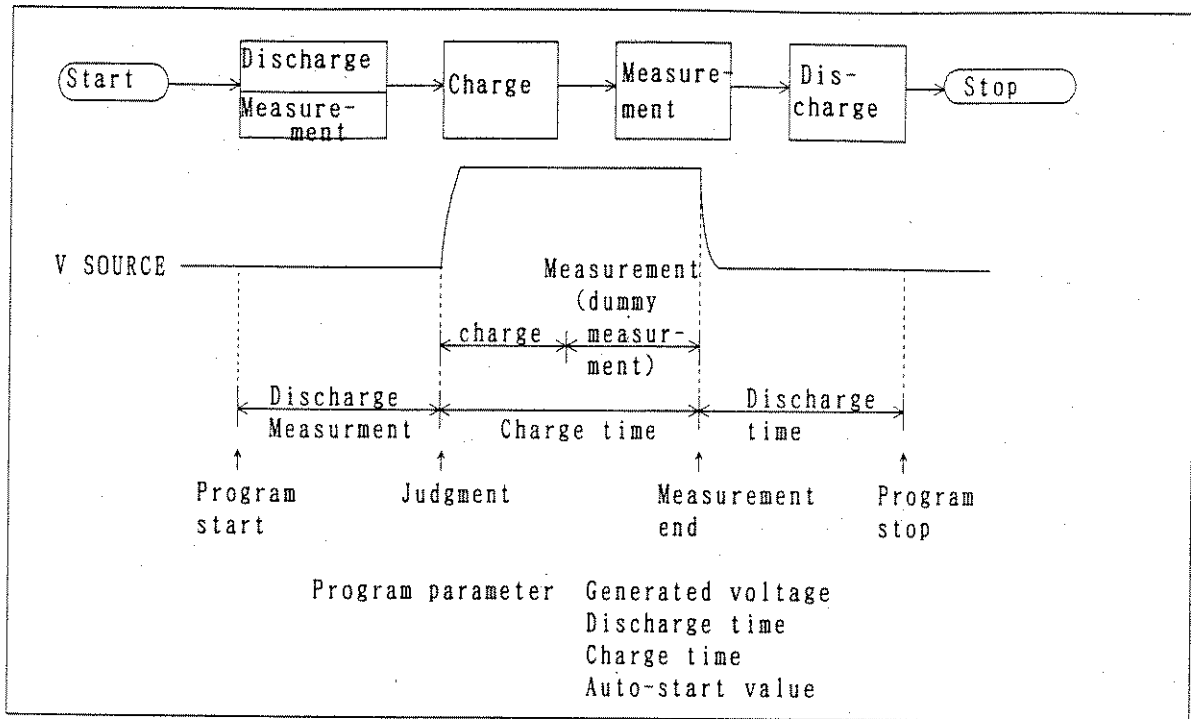

When the program No.4 is started, current is measured while executing discharge. When the measured current value is lower than the preset auto-start value, discharge is judged to be ended and charge starts. When the charge time elapses; one-time measurement ends, discharge starts, and the program ends.

CAUTION

1. For the charge time 2.001 seconds or more, the dummy measurement will be started at half time of the charge time.
2. For the charge time 2.000 seconds or less, the dummy measurement is not done.



## 5.2 Execution of Sequence Program

The following shows how to execute sequence program and operations during execution.

Operation (① through ⑤)

- ① When the  <sup>PRGM/NORMAL</sup> is pressed; the LED lights, the program mode is set, and the following indication appears.

Display panel state for execution

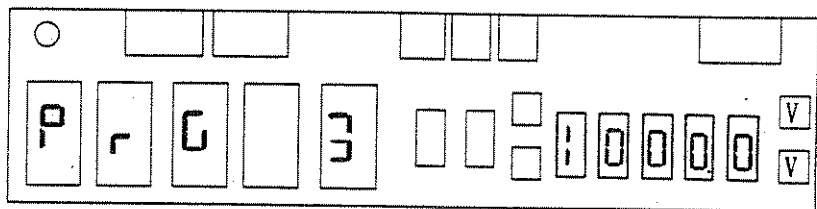

Program mode

The presently set program No. and set voltage are displayed. Subsequently, description is continued by using the program No.3 as an example. In the program mode, discharge state is

set before execution of the program. When the  <sup>PRGM/NORMAL</sup> is pressed again, the program mode is canceled and the state returns to the normal measurement mode.

- ② Press the  <sup>OPERATE</sup> to set the V-SOURCE to OPERATE state (LED lights). If the V-SOURCE is stand-by (LED goes out), no program can be executed. Therefore, be sure to set OPERATE state.
- ③ When the  <sup>START</sup> is pressed, the LED lights and the program starts.

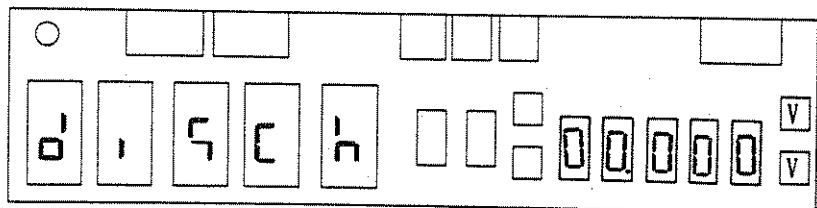

Discharge

Discharge continues for the time set by parameters. The discharge-key LED lights.

↓  
A

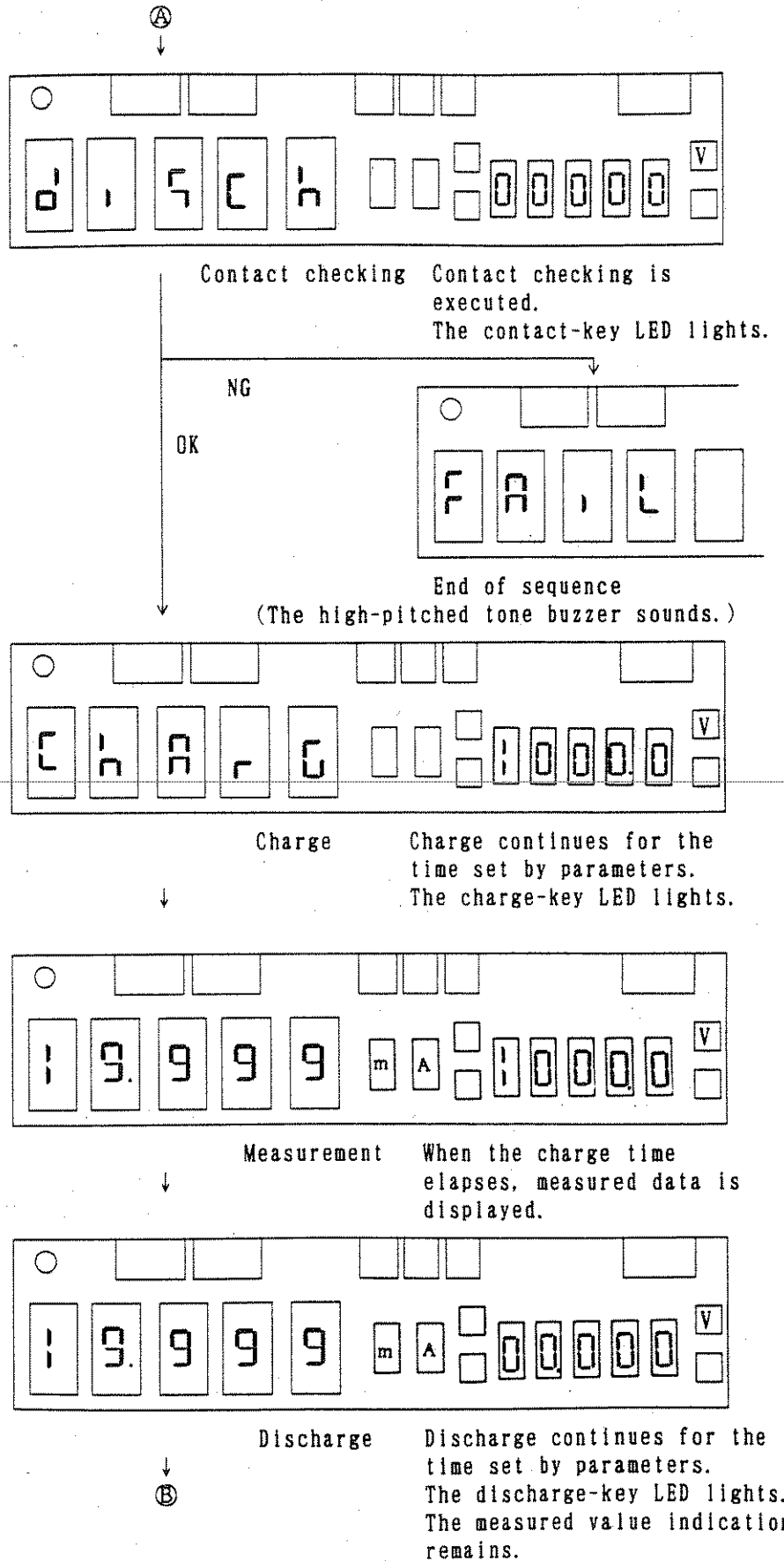

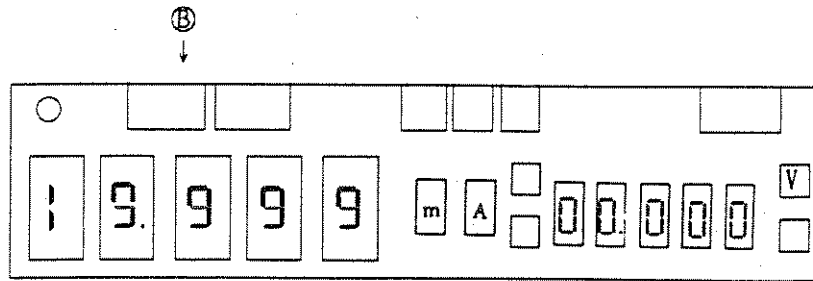



End of sequence Start-key LED goes out.  
(The low-pitched tone buzzer sounds.)

The operation ends with the measured value displayed.  
When the buzzer is set to ON, it sounds.

④ Cancel During Execution of Program

To cancel the program during execution of it, execute the operation as follows:

- ④-1 Press the <sup>PRGM/NORMAL</sup> , and the program mode is canceled and also the program is canceled.
- ④-2 Press the <sup>START</sup> , and the LED goes out to stop the sequence and discharge state is set. When measurement is already ended, measured data is displayed.
- ④-3 Press the <sup>OPERATE</sup>  to make V-SOURCE stand-by, and the sequence ends and the initial program No. is displayed.

⑤ Start/stop Using LID SIGNAL

The program can also be started or stopped with the LID SIGNAL. The program can be started or stopped by operating the lid on the fixture of the R12701 and R12704 with the signal. For detailed usage, see Section 7 "INPUT/OUTPUT SIGNALS" and Section 11 "APPLIED MEASUREMENT".  
Table 5-1 shows keys effective for each mode.  
Table 5-2 shows the status change of each mode.

Table 5 - 1 Keys Effective for Each Mode  
(Excluding the case in which the GPIB is controlled)





Normal measurement mode	Program mode (During stop of program)	During execution of program
All keys	All keys. However, the <sup>CAL</sup>  function changes. See Table 5-3.	<sup>PRGM/NORMAL</sup>  <sup>START</sup>  <sup>OPERATE</sup> 

Table 5 - 2 Status Change of Each Mode

	Normal measurement mode	Program mode	During execution of program
IM/RM	Follow the key setting	Follow the key setting	←
Range	Follow the key setting	Follow the key setting	←
Sampling	Follow the key setting	HOLD	HOLD
NULL	Follow the key setting	OFF	←
COMPARE	Follow the key setting	Follow the key setting	←
State	Follow the key setting	Discharge	Follow the sequence
V SOURCE	Follow the key setting	Follow the key setting	Follow the sequence
Operation/ stand-by	Follow the key setting	Follow the key setting	No execution can be made under stand-by state.

Note: The arrow " ← " shows that the state depends on the left state



### 5.3 Setting of Program Parameters

Program parameters other than generated voltage value can be set because the CAL key function changes only in the program mode

( LED lights). It is also possible to set only necessary parameters according to the set program No. Set the generated voltage value and so on similarly to normal measurement. No parameter can be set during execution of the program.

The following is the initialization value of each program parameter.

- Generated voltage :0V
- Program No. :No.0
- Auto-start value :1.00pA
- Charge time :60 sec
- Discharge time :1 sec
- Measurement time :0 sec

The initialization value is obtained by executing the "power-on initialize" operation (press the  immediately after turning on the power switch).

Table 5-3 shows the CAL key function in the program mode.

Table 5 - 3 CAL key Function (In program mode)

Contents	Operation1	Operation2
1. Setting of program No.	Press the <input type="checkbox"/> once.	PRGM No. <input type="checkbox"/> 0 <input type="checkbox"/> 1 <input type="checkbox"/> 2 <input type="checkbox"/> 3 <input type="checkbox"/> 4 <input type="checkbox"/> 5 } Whenever <input type="checkbox"/> is pressed, the setting is changed over.
2. Setting of auto-start value (PRGM No.4 only)	Press the <input type="checkbox"/> twice.	A. STAT Set data with numerical keys.
3. Setting of charge time	Press the <input type="checkbox"/> three times. (For PRGM No.4) Press the <input type="checkbox"/> twice. (Other than PRGM No.4)	CHARG T Set data with numerical keys.

Table 5 - 3 CAL key Function (In program mode) (Cont'd)

Contents	Operation1	Operation2
4. Setting of discharge time (Other than PRGM No. 0)	Press the <sup>CAL</sup> <input type="checkbox"/> four times. (For PRGM No. 4)  Press the <sup>CAL</sup> <input type="checkbox"/> three times. (Other than PRGM No. 4)	DISCH T Set data with numerical keys.
5. Setting of measurement time (PRGM No. 5 only)	Press the <sup>CAL</sup> <input type="checkbox"/> five times.	MEAS T Set data with numerical keys.
6. When the <sup>CAL</sup> <input type="checkbox"/> is pressed again, the state returns to "1".		

## (1) How to Set Program No.

## Operation (① through ④)

① Press the <sup>PRGM/NORMAL</sup>  to set the program mode (LED lights).

② Press the <sup>CAL</sup>  once.

③ Press the <sup>CHANGE</sup>  to set the required program No.

Whenever the <sup>CHANGE</sup>  is pressed, the setting is changed over.

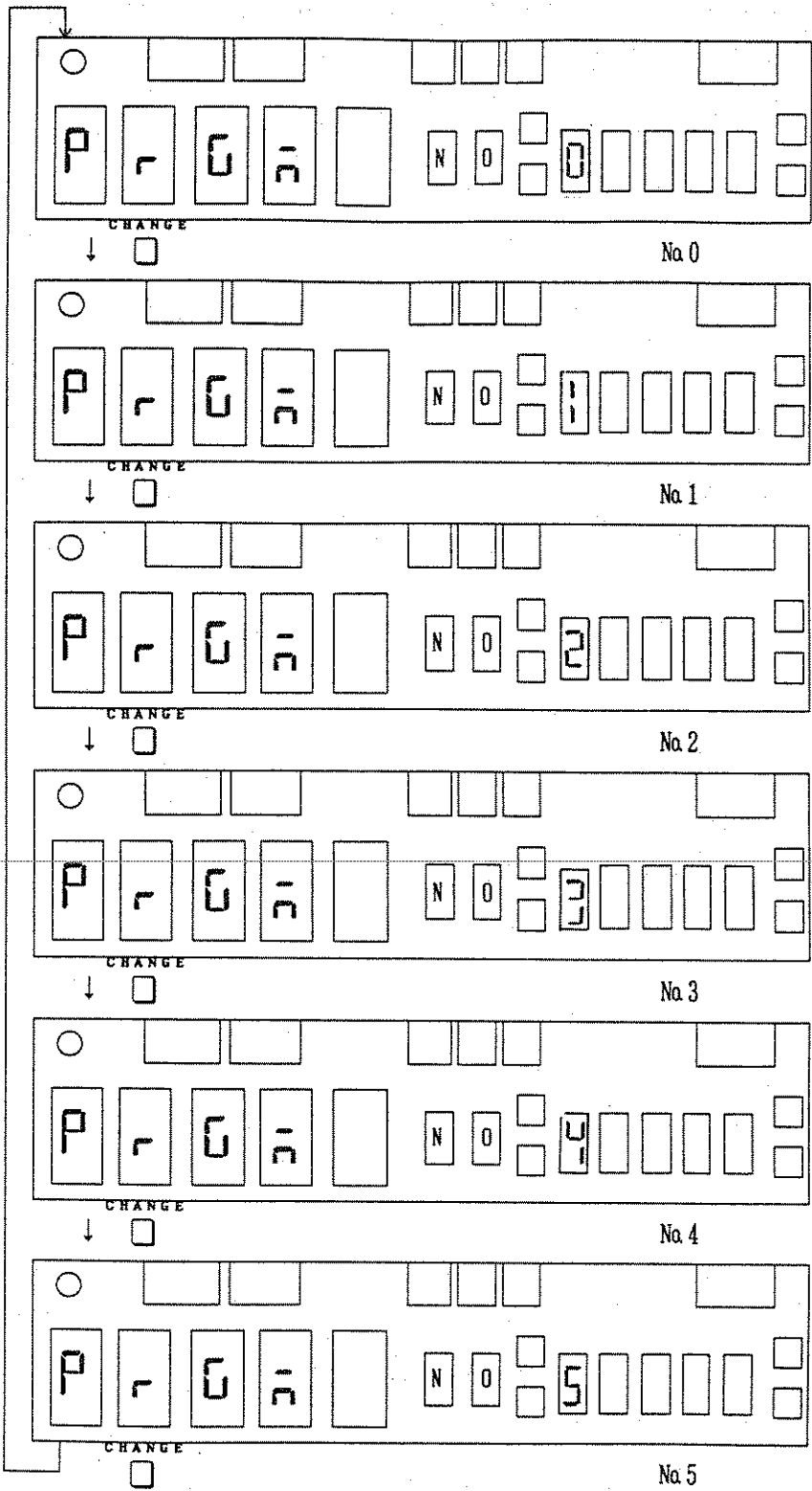

④ When the  is pressed, the setting ends.

## (2) How to Set Auto-start Value (Program No.4 only)

## Operation (① through ④)

- ① Press the <sup>PRGM/NORMAL</sup>  to set the program mode (LED lights).
- ② Select the program No.4 in the above Item (1).
- ③ Press the <sup>CAL</sup>  twice.

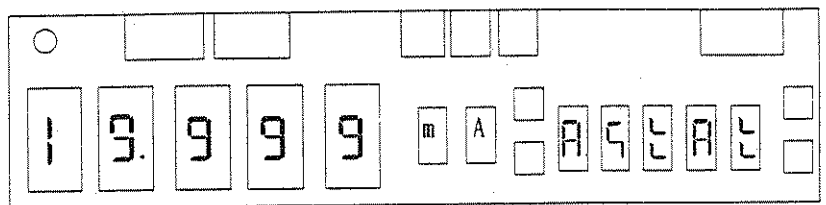

Present set value

- ④ Set a value according to the procedure in Item 4.4.1 "Upper level".

## CAUTION

1. The auto-start value setting range is -19.999mA to +19.999mA. If a value exceeding the above range is set, an error occurs when the <sup>EXIT</sup>  is pressed.
2. If you input an incorrect value, press the  <sub>CE</sub>. Then the preceding set value appears and you can input a new value.
3. The auto after function start for  $|IM| \leq |set\ value|$ .
4. If a small auto-start value such as 0.00pA is set, discharge state may continue for a long time.

## (3) How to Set Charge Time

## Operation (① through ④)

- ① Press the <sup>PRGM/NORMAL</sup>  to set the program mode (LED lights).
- ② Press the <sup>CAL</sup>  twice if a program other than the program No.4 is set or three times if the program No.4 is set.
- ③ Change the present set value to the required set value. To change the to setting to 12.345 set, for example:

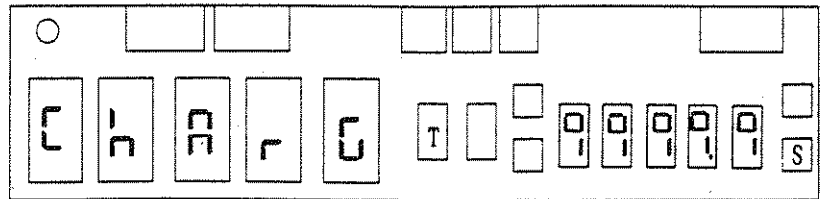

↓ Press the <sub>1</sub> <sub>2</sub>  <sub>3</sub> <sub>4</sub> and <sub>5</sub> .

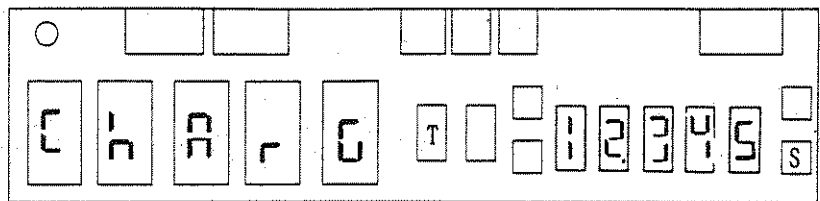



- ④ When the <sup>EXIT</sup> is pressed, the setting ends.

CAUTION

1. The charge-time setting range is 00.000 to 9999.9 sec. If a value exceeding the above range is set, an error occurs.
2. If you input an incorrect value, press the <sub>CE</sub>. Then the preceding set value appears and you can input a new value.



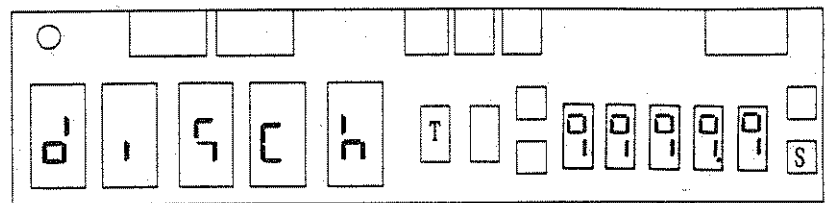

## (4) How to Set Discharge Time

## Operation (① through ④)

- ① Press the <sup>PRGM/NORMAL</sup>  to set the program mode (LED lights).
- ② Press the <sup>CAL</sup>  three times if a program other than the program No.4 is set or four times if the program No.4 is set.
- ③ Change the present set value to the required set value.  
To change the setting to 12.345 sec, for example:



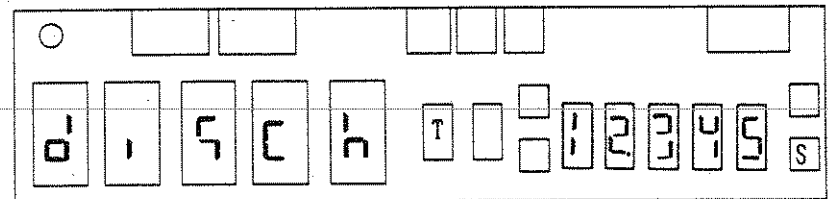

Present set value

↓ Press the     and .



- ④ When the <sup>EXIT</sup>  is pressed, the setting ends.

## CAUTION

1. The discharge-time setting range is 00.000 to 9999.9 sec. If a value exceeding the above range is set, an error occurs when the <sup>EXIT</sup>  is pressed.
2. If you input an incorrect value, press the .  
Then the preceding set value appears and you can input a new value.

## (5) How to Set measurement time (Program No. 5 only)

Operation ( ① through ⑤ )

- ① Press the  <sup>PRGM/NORMAL</sup> to set the program mode (LED lights).
- ② Select the program No.5 in the above Item (1).
- ③ Press the  <sup>CAL</sup> four times.
- ④ Change the present set value to the required set value.  
To change the setting to 12.345 sec. for example:

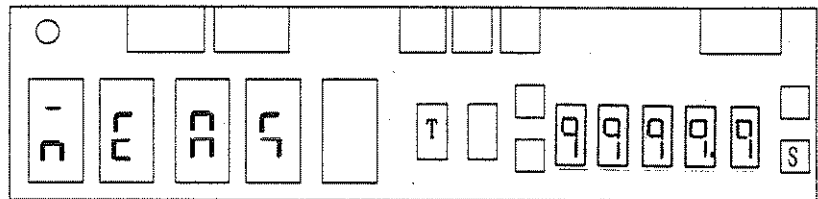

Present set value

↓ Press the <sub>1</sub> <sub>2</sub> <sub>3</sub> <sub>4</sub> and <sub>5</sub>.

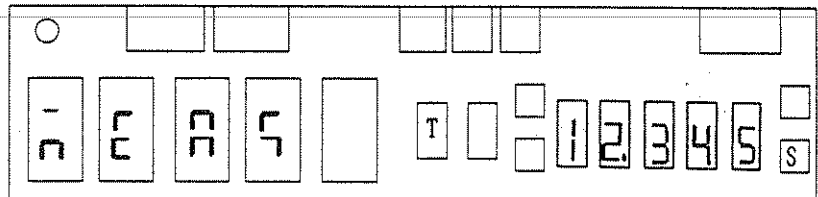

- ⑤ When the  <sup>EXIT</sup> is pressed, the setting ends.

## CAUTION

- The Measurement time setting range is 0 to 9999.9 sec. If a value exceeding the above range is set, an error occurs when the  <sup>EXIT</sup> is pressed.
- If you input an incorrect value, press the  <sub>CE</sub>. Then the preceding set value appears and you can input a new value.

## 5.4 Sequence Program Operation Example

The following example describes sequence program operations from sample connection to end of program.

**Example 1 Resistance measurements using program 0, 1 and 2**

Requirements	IM/RM	RM (Resistance measurement)
	RANGE	AUTO
	VS	25V
	Integral time	5PLC
	GAIN	$\times 10000$
	Charge time	30 seconds
	Discharge time	60 seconds (except program 0)
	Other settings	The same as during power on initialization

## (1) Input Cable Connections

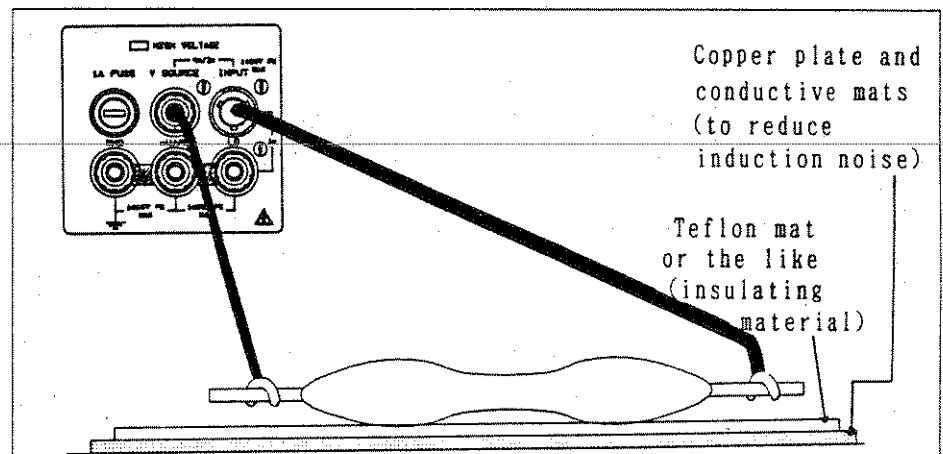

A shielding plate or shielding box is required when the measured current is  $10^{-8}$ A or less since the meter is particularly susceptible to induction noise in this range.



(2) Resistance Measurement

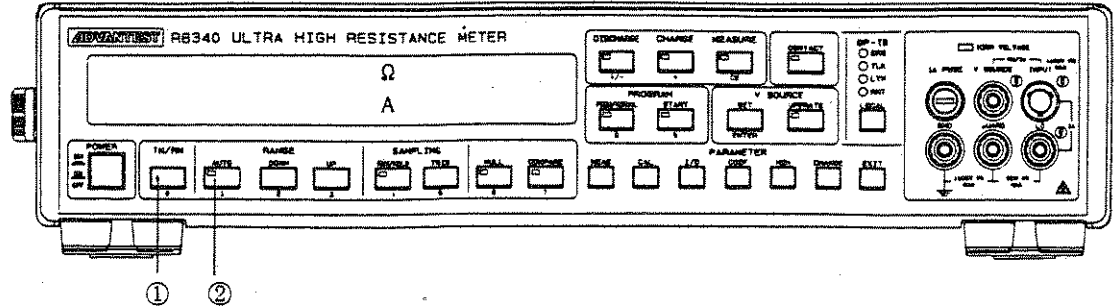

- ① Press  <sup>IM/RM</sup> to display the ohm mark.
- ② Set the instrument to auto range by pressing  <sup>AUTO</sup>. Make sure that the key LED goes on.

(3) Applied Voltage Setting (25V)

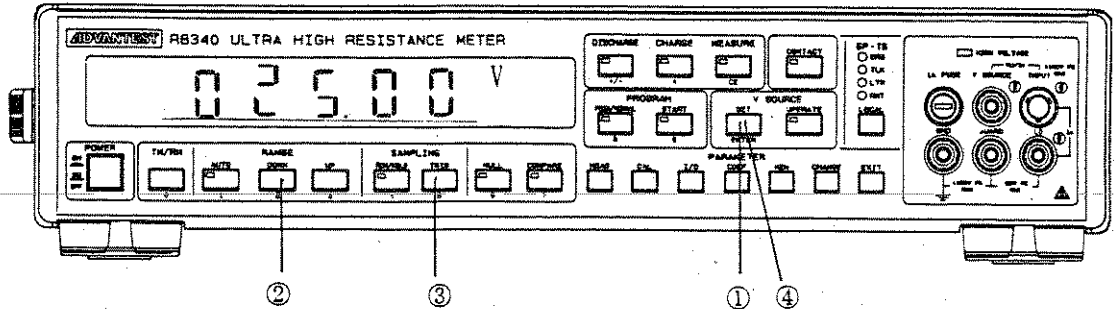

Press ①  <sup>V SOURCE</sup> ②  <sub>2</sub> ③  <sub>5</sub> and ④  <sup>SET</sup> <sub>ENTER</sub> to display 025.00V.

## (4) Integral Time Setting

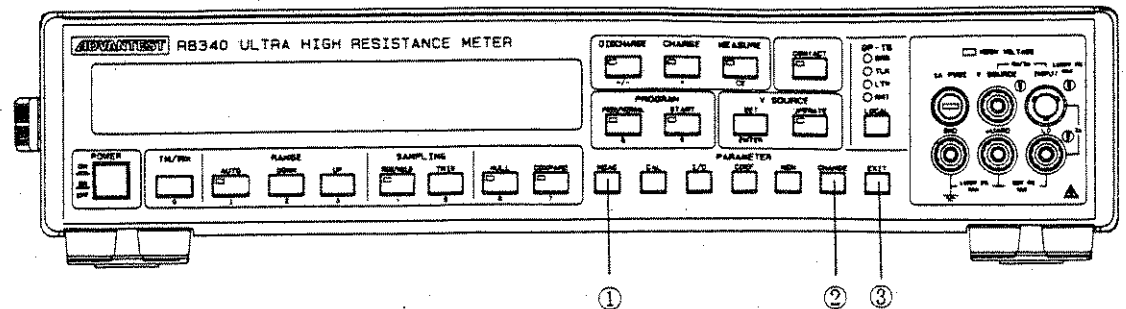

MEAS CHANGE  
Press ①  and ②  to set 5PLC.

EXIT  
Press ③  to cancel or terminate the setting.

## (5) Gain Measurement

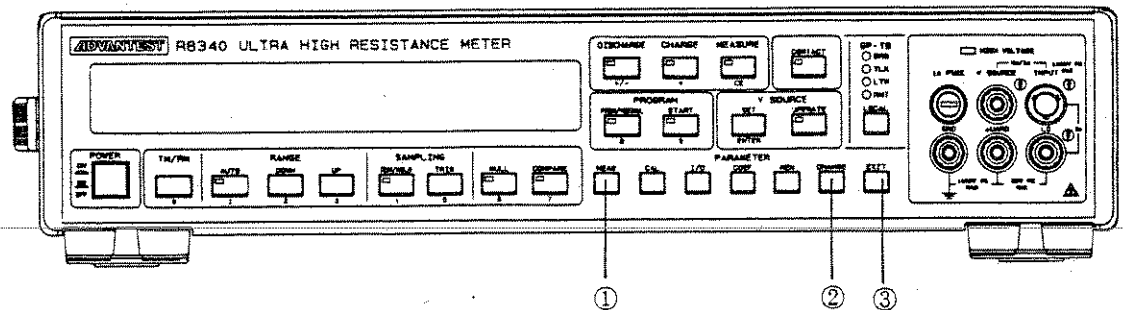

MEAS  
Press ①  three times and set the meter to  $\times 10000$  with

CHANGE  
②

EXIT  
Press ③  to cancel or terminate the setting.

## (6) Program Number Setting

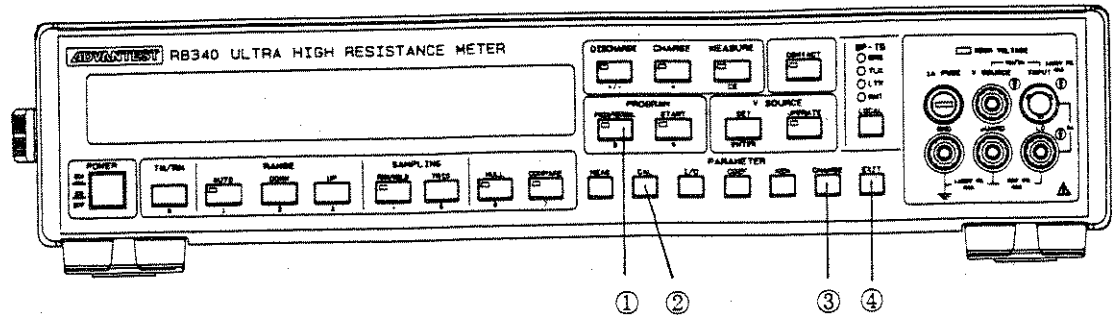

Press ①  and make sure that the key LED goes on.

Press ② . Use ③  to set 0, 1 or 2.

Press ④  to cancel or terminate the the setting.

## (7) Charge Time Setting

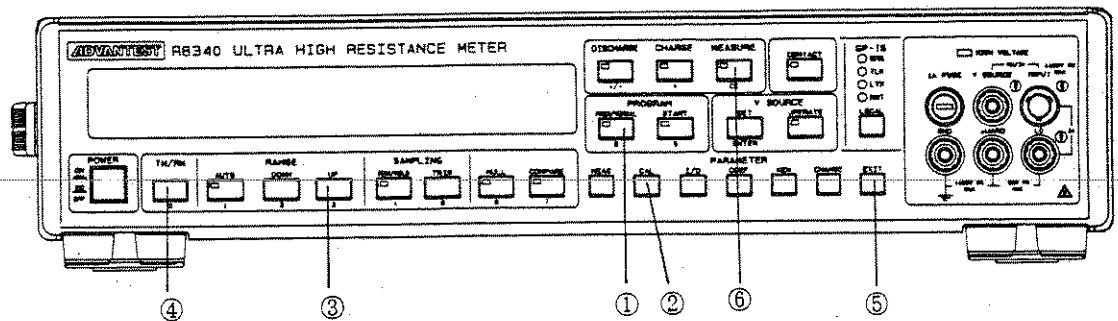

Press ①  and make sure that the key LED goes on.

Press ②  twice. Press ③  ④  ⑤ .

The previous setting is redisplayed when ⑥  is pressed while a setting is made.

(8) Discharge Setting

Note : This setting cannot be made in program No. 0.

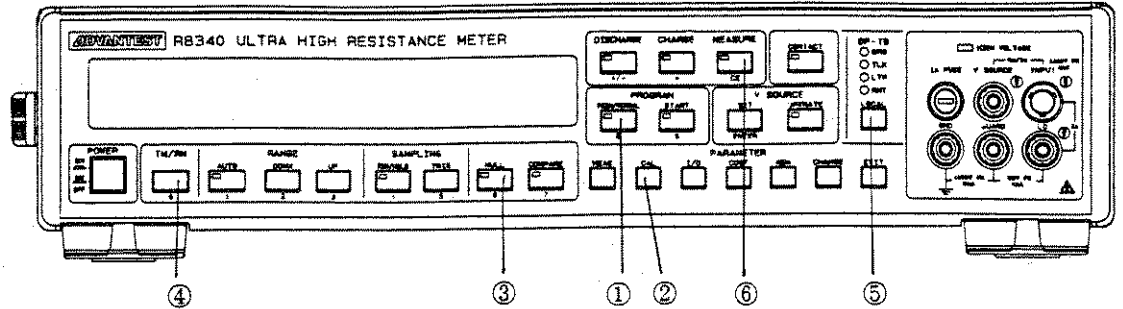

Press ①  <sup>PRGM/NORMAL</sup> and make sure that the key LED goes on.

Press ②  <sup>CAL</sup> three times.

Press ③  ④  ⑤  <sup>EXIT</sup>.

The previous setting is redisplayed when ⑥  <sup>MEASURE</sup> <sub>CE</sub> is pressed while a setting is made.

(9) Setting Sequence Program No. 0

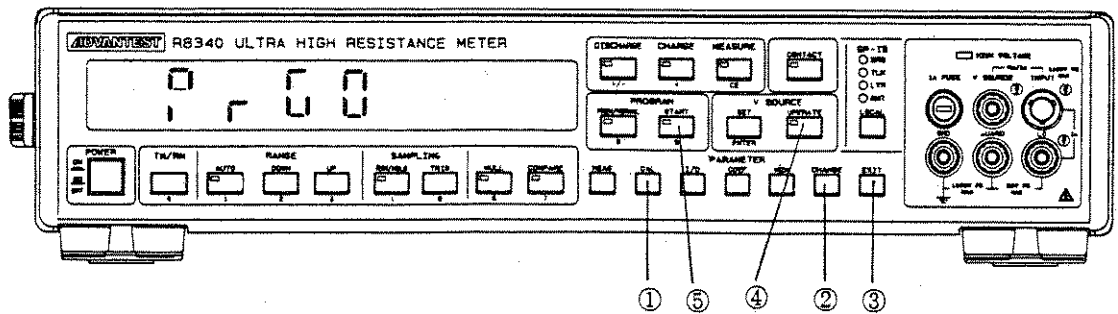

Make sure that "0 r 0 0" is displayed. If not, press ①  <sup>CAL</sup> and ②  <sup>CHANGE</sup> to make the setting. Then press ③  <sup>EXIT</sup>.

Press ④  <sup>OPERATE</sup> and ⑤  <sup>START</sup>.

## (10) Setting Sequence Program No.1 and 2

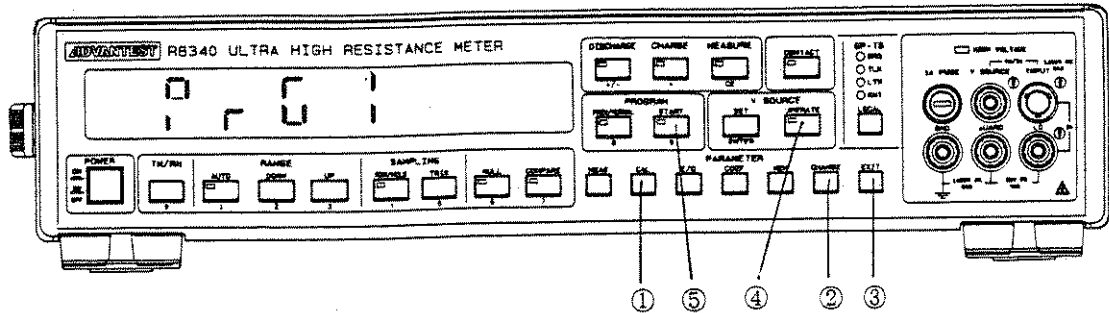

Make sure that "1.201" or "1.202" is displayed. If not, press ①  and ②  to set 1 or 2.  
 Press ③ .

If the previous setting was "1.000" or the like, perform procedures (6) and (8) to set the time of the disk.  
 Press ④  and ⑤ .

**Example 2 Measuring insulation resistance between capacitor terminals using program No.3**

Requirements	IM/RM	RM (Resistance measurements)
	RANGE	AUTO
	VS	100V
	Integral time	10PLC
	GAIN	× 10
	Autorange UP/DOWN level	2000
	Charge time	60 seconds
	Discharge time	120 seconds
	Other settings	The same as during power on initialization

(1) Input Cable Contact

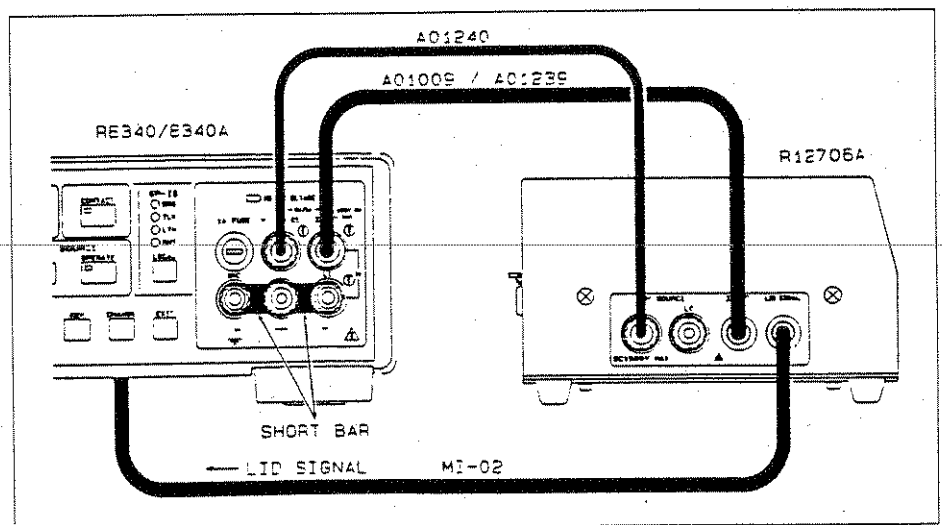

The voltage to be measured in a measurement of the insulation resistance between capacitor terminals is extremely small and therefore susceptible to induction noise. Use of the R12701 or R12706A test fixture are recommended. Since a contact check is made in the program No.3 sequence, a contact initialization offset measurement (See Section 4.3.2) and contact initialization measurement (See Section 4.3.3) should be made before starting this sequence.

## (2) Resistance Measurement Setting

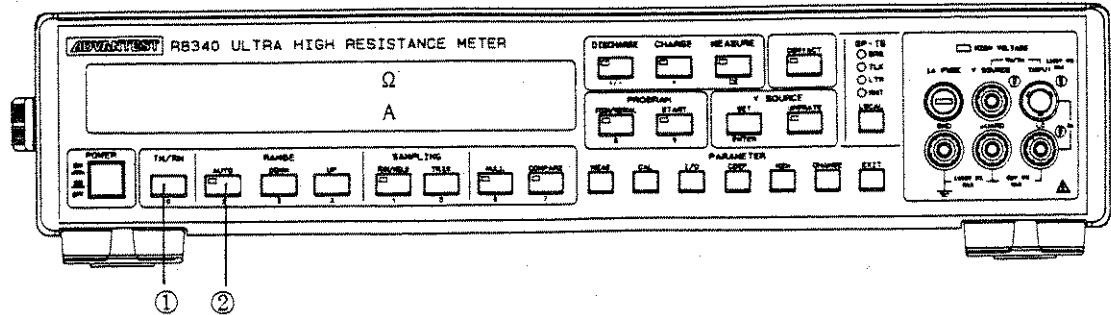

Press ①  to display the ohm mark.

Press ②  to make auto range setting. Make sure that the LED goes on.

## (3) Setting the Applied Voltage (100V)

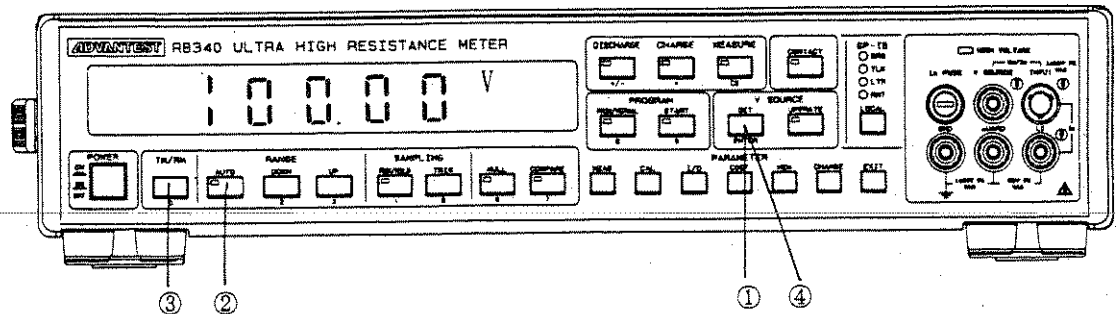

Press ①  ②  ③  ③  and ④  to display 100.00V.

## (4) Integral Time Setting

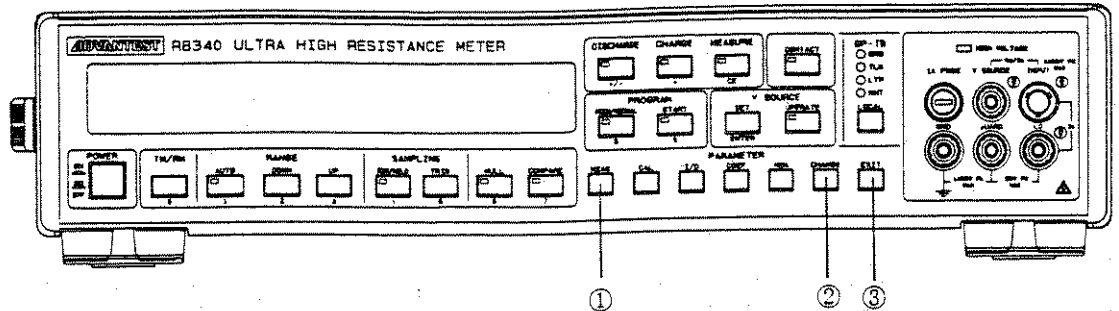

Press ①  MEAS and ②  CHANGE to set 10PLC.

Press ③  EXIT to cancel or terminate the setting.

## (5) Gain Setting

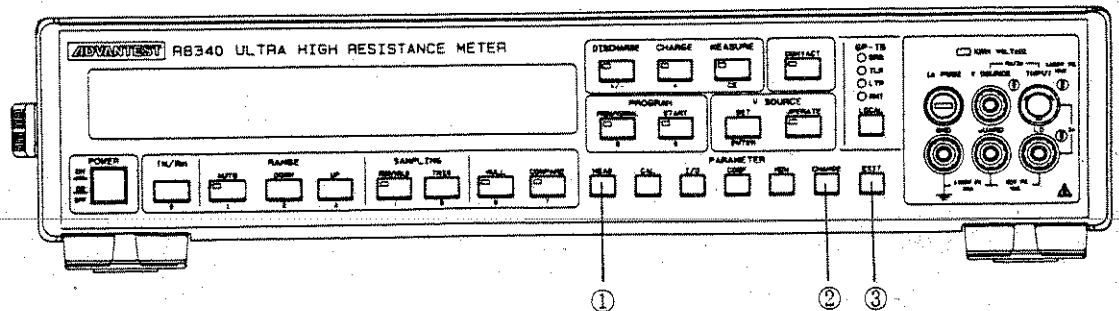

Press ①  MEAS three times and use ②  CHANGE to set  $\times 10$ .

Press ③  EXIT to cancel or terminate the setting.



## (6) Autorange UP/DOWN Level Setting

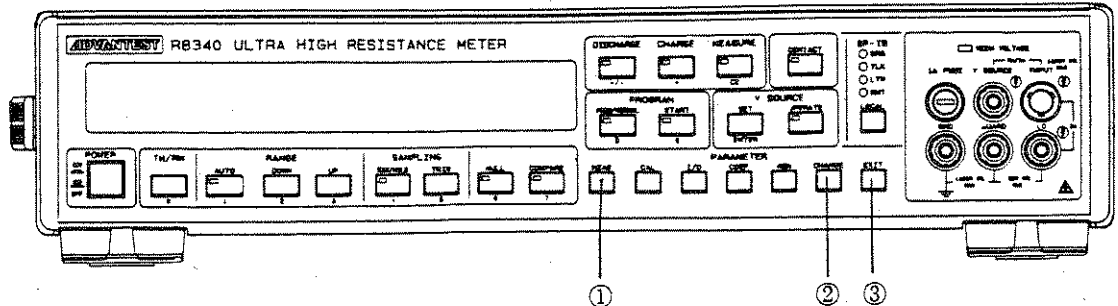

MEAS CHANGE  
 Press ①  five times and use ②  to set 2000.  
 EXIT  
 Press ③  to cancel or terminate the setting.

## (7) Program No. Setting

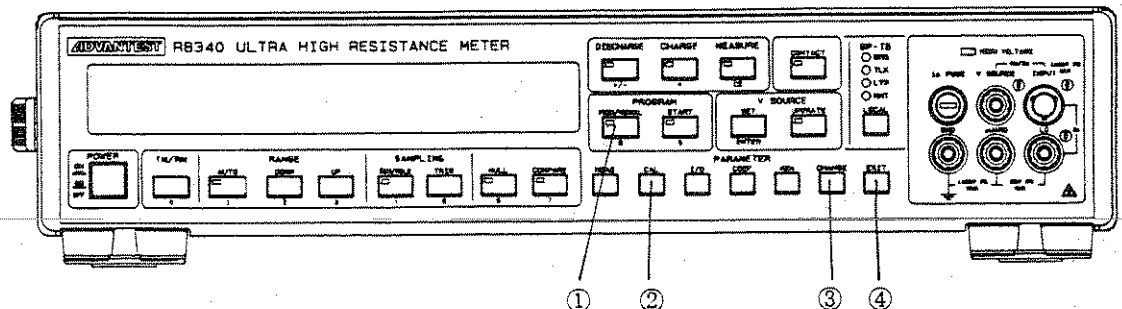

PRGM/NORMAL  
 Press ①  and make sure that the key LED goes on.  
 CAL CHANGE  
 Press ② . Use ③  to set 3.  
 EXIT  
 Press ④  to cancel or terminate the setting.

## (8) Charge Time Setting

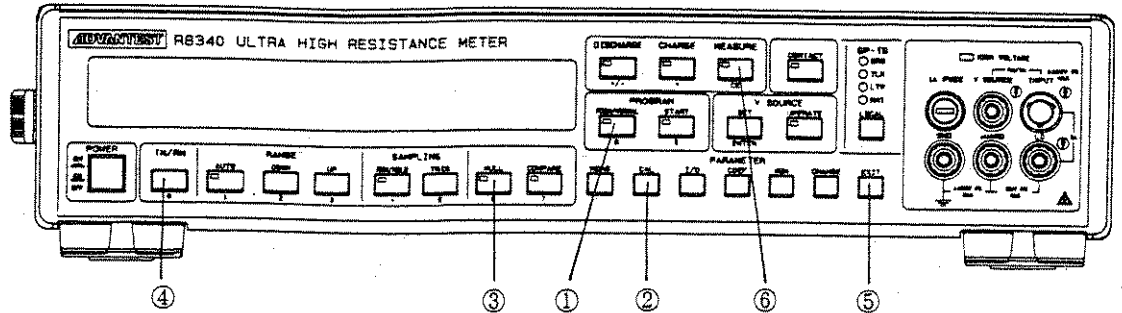

Press ①  and make sure that the key LED goes on.

Press ②  twice. Press ③  ④  and ⑤  .

Previously set values are displayed when ⑦  is pressed during setting.

## (9) Discharge Time Setting

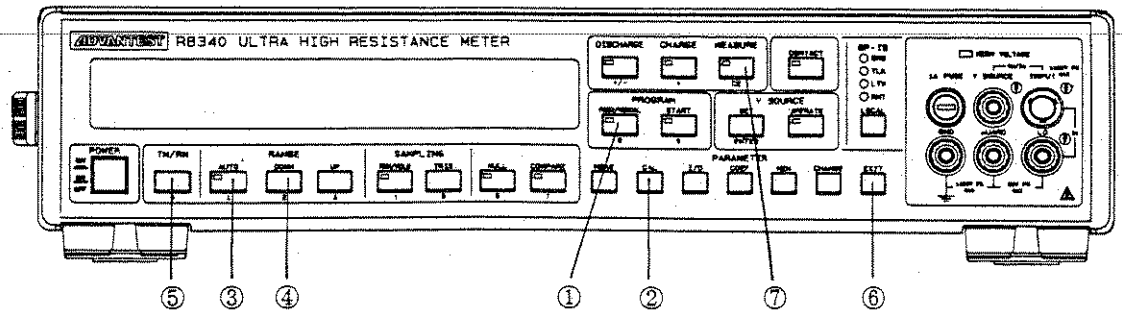

Press ①  and make sure that the key LED goes on.

Press ②  three times. Press ③  ④  ⑤  and ⑥  .

Previously set values are displayed when ⑦  is pressed during setting.

## (10) Sequence Program No. 3 Measurements

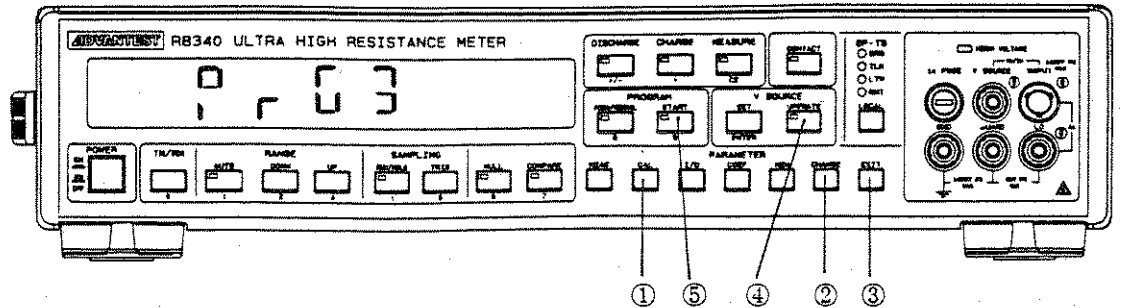

Make sure that "0. r 0.3" is displayed. If not, press

①  CAL and ②  EXIT to set 3. Then press ③  START.

Press ④  OPERATE and ⑤  CHANGE.

**Example 3 Surface resistivity measurement of sheet samples using program No. 4**

Requirements	IM/RM	RM (Resistance measurement)
	Display	Surface resistivity
	Diameter of main electrode	50 $\phi$
	RANGE	AUTO
	VS	500V
	Integral time	10PLC
	GAIN	$\times 10$
	Unit display	Exponents
	Automatic start value	10PA
	Charge time	60 seconds
	Discharge time	60 seconds
	Other settings	The same as during power on initialization

(1) Input Cable Connections

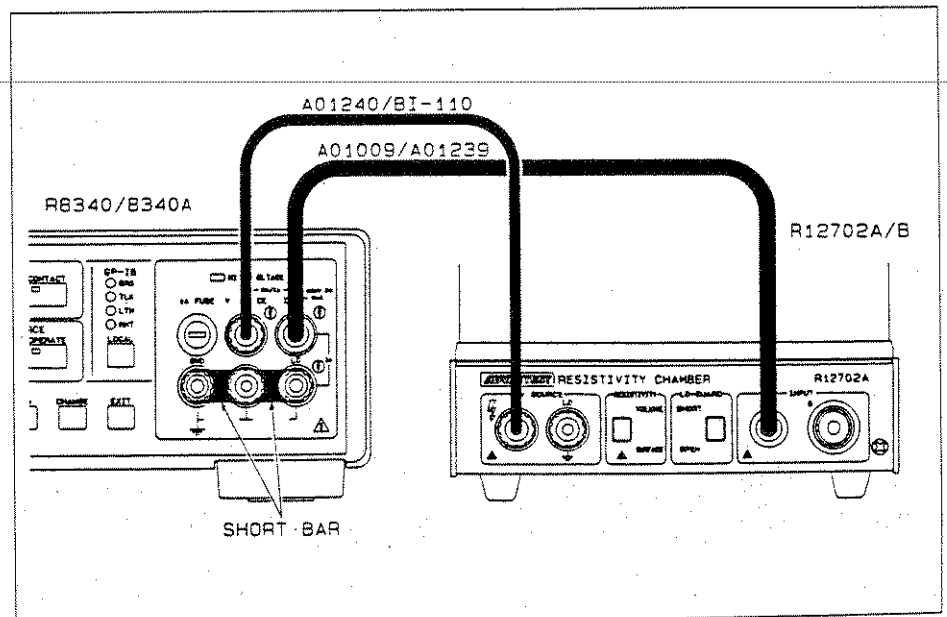

The R12702A/B, R12704, TR42 and TR43C allow surface resistivity measurements and volume resistivity measurements of sheet samples.

When the R12702A/B or R12704 are used, set to SURFACE (surface resistivity). When the TR42 and TR43C, use the short bar to set to SURFACE (surface resistivity).

(2) Setting Resistance Measurement

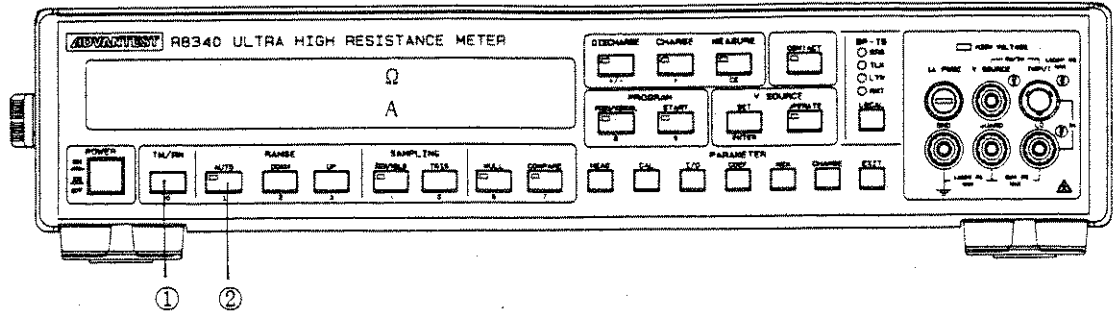

Press ①  IM/RM to display the ohm mark.

Press ②  AUTO and make sure that the key LED goes on.

(3) Applied Voltage Setting (500V)

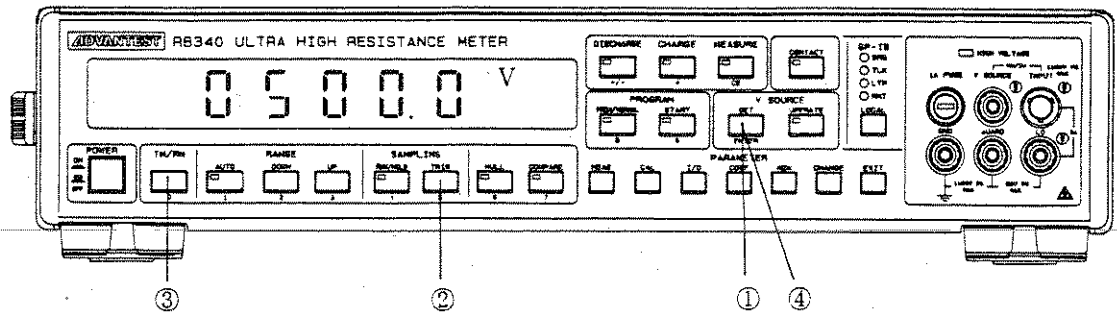

Press ①  SET ②  5 ③  0 ③  0 and ④  ENTER to display 0.500.0V.

## (4) Integral Time Setting

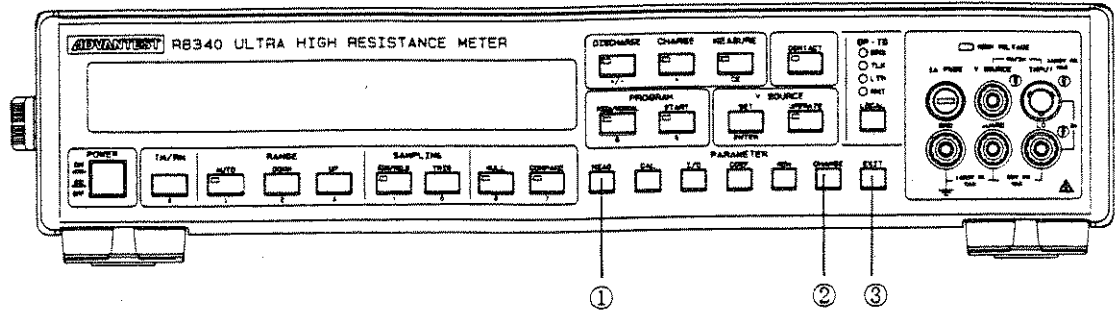

MEAS CHANGE  
Press ①  and ②  to set 10PLC.

EXIT  
Press ③  to cancel or terminate the setting.

## (5) Gain Setting

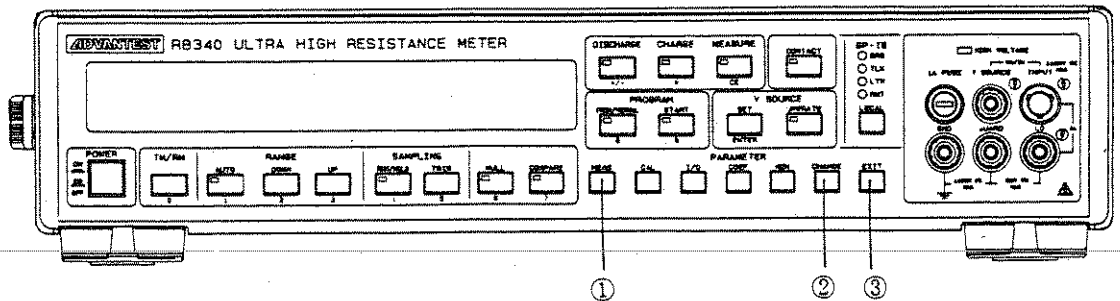

MEAS CHANGE  
Press ①  three times and use ②  to set  $\times 10$ .

EXIT  
Press ③  to cancel or terminate the setting.

## (6) Setting Exponent Unit Display

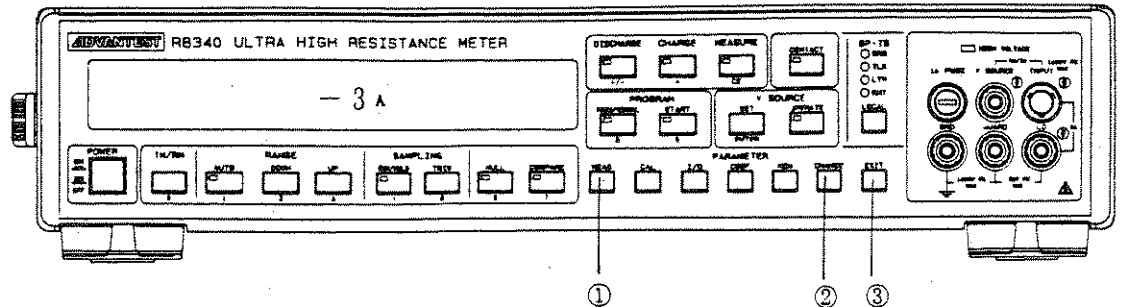

MEAS CHANGE  
Press ①  six times and set -3A with ② .  
EXIT  
Press ③  to cancel or terminate the setting.

## (7) Surface Resistivity Display Setting

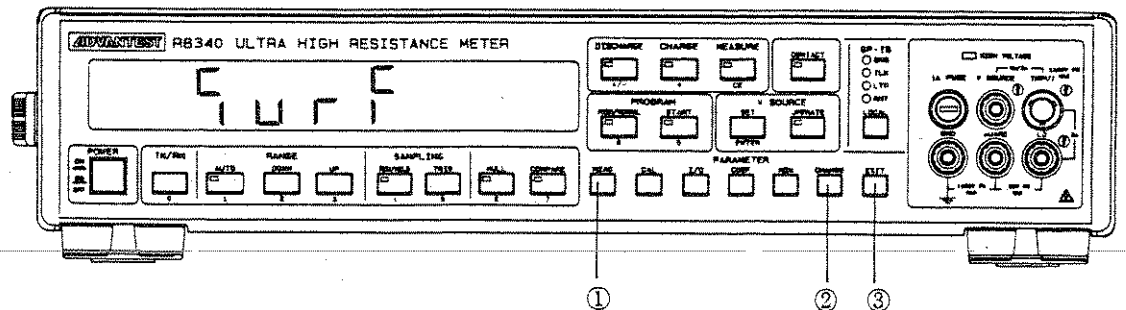

COEF CHANGE  
Press ①  three times and ②  to set "SURF"  
(surface resistivity)  
EXIT  
Press ③  to cancel or terminate the setting.

## (8) Electrode Diameter Setting

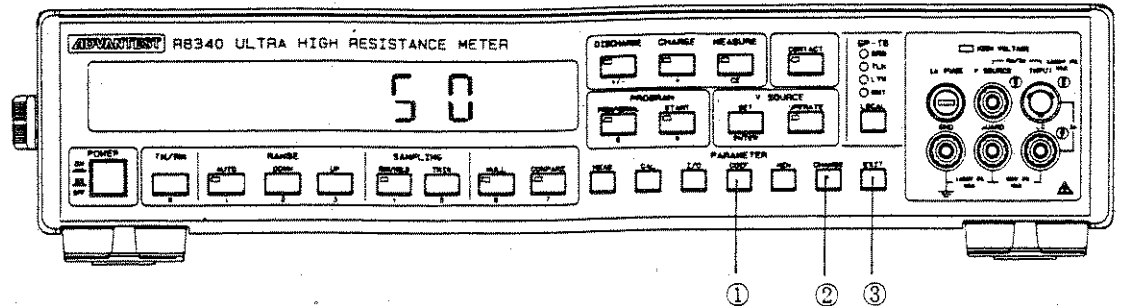

Press ①  COEF four times and use ②  CHANGE to set to 50.  
 Press ③  EXIT to cancel or terminate the setting.

## (9) Program No. Setting

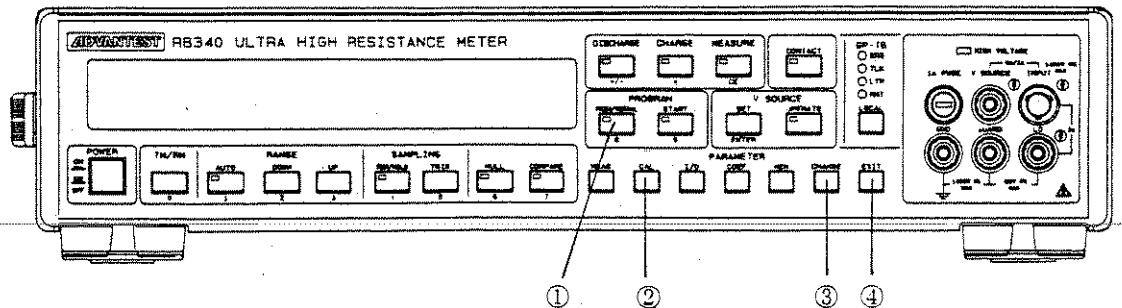

Press ①  PRGM/NORMAL and make sure that the key LED goes on.  
 Press ②  CAL. Use ③  CHANGE to set 4.  
 Press ④  EXIT to cancel or terminate the setting.



## (10) Automatic Start Value Setting (10pA)

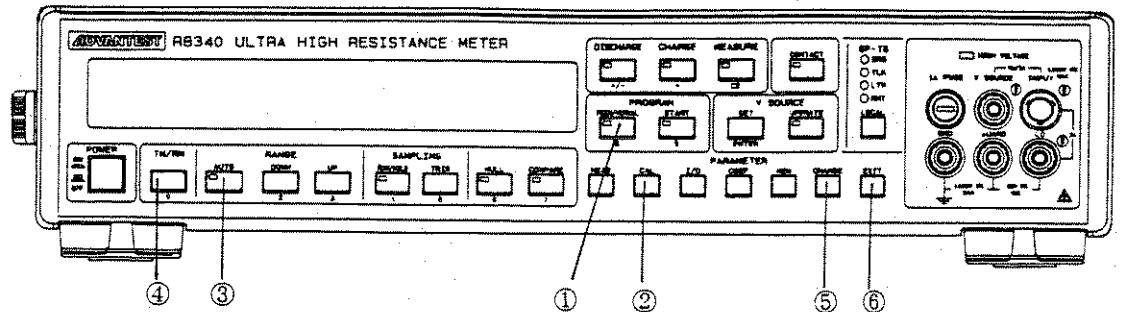

PRGM/NORMAL  
Press ①  and make sure that the key LED goes on.

CAL  
Press ②  twice. Press ③  ④  and use ⑤  CHANGE  
to set the range to 10.00pA. Then press ⑥  EXIT

## (11) Charge Time Setting

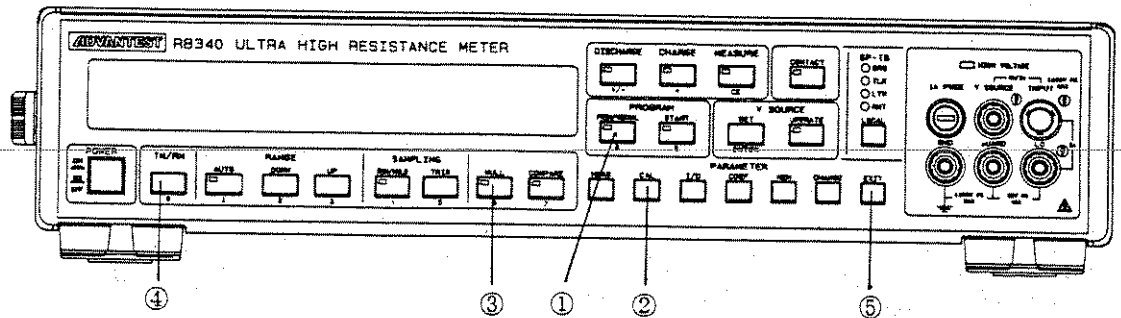

PRGM/NORMAL  
Press ①  and make sure that the key LED goes on.

CAL  
Press ②  three times.

Press ③  ④  and ⑤  EXIT

(12) Discharge Time Setting

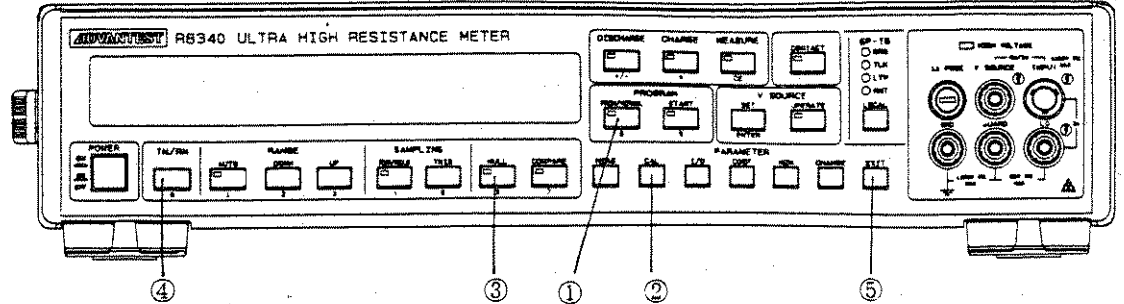

Press ①  and make sure that the key LED goes on.  
 Press ②  four times. Press ③  ④  and ⑤

(13) Sequence Program No. 4 Measurements

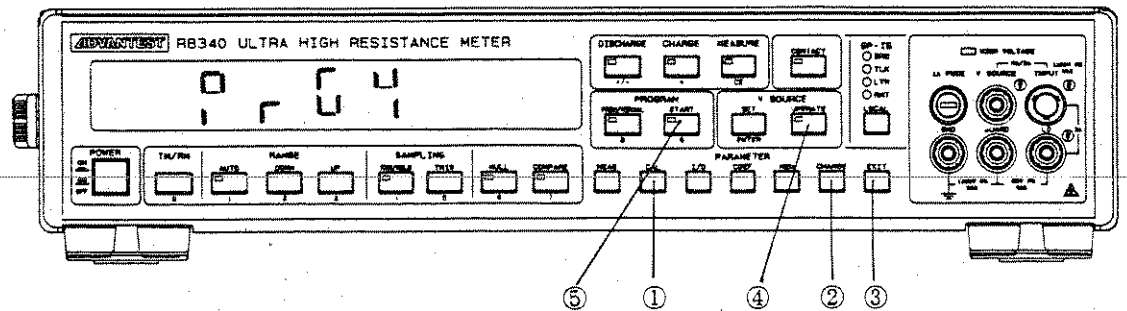

Make sure that "P r 0 4" is displayed. If not, press ①  and ②  to set 4. Then press ③ .

Press ④  and ⑤ .

**Example 4 Measuring insulation resistance between capacitor terminals using program No.5**

Requirements	IM/RM	RM (Resistance measurement)
	RANGE	AUTO
	VS	160V
	Integral time	10PLC
	GAIN	×1
	Autorange UP/DOWN level	200
	Autorange delay	2 seconds
	Charge time	30 seconds
	Discharge time	120 seconds
	Measuring time	30 seconds
	Other settings	The same as during power on initialization

(1) Input Cable Connections

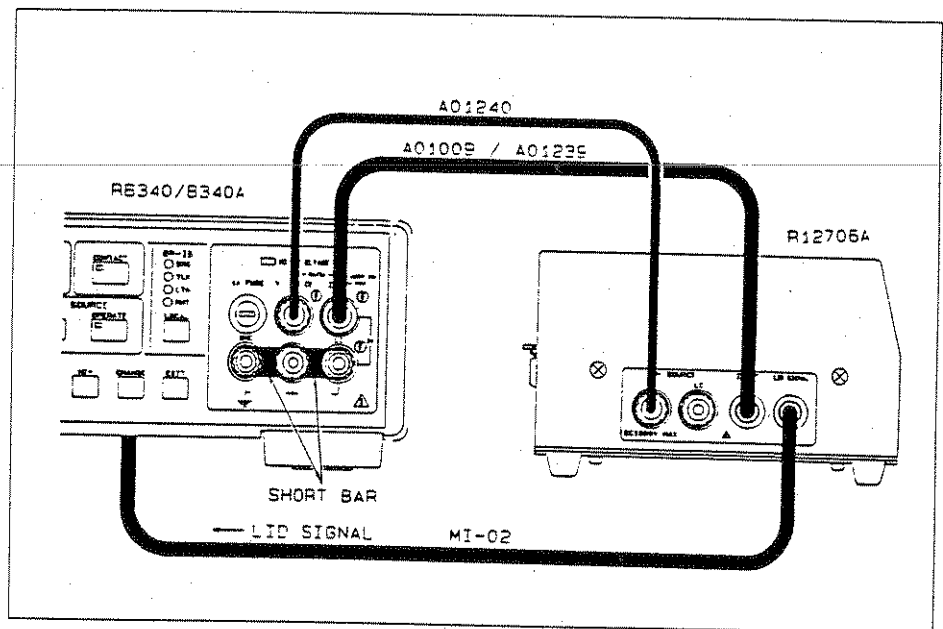

When the capacity of the sample is of the order of  $\mu$ F, the input resistance and capacity lengthens the time constant so much that the ranging function cannot operate normally leading to errors in the measurements made after charging. In order to prevent ranging error operation, reduce the auto range UP/DOWN level lower the input resistance and enter an auto range delay. When program No.5 is used, perform internal sampling after charging to set optimum range to ensure highly accurate measurement results.

(2) Resistance Measurement Setting

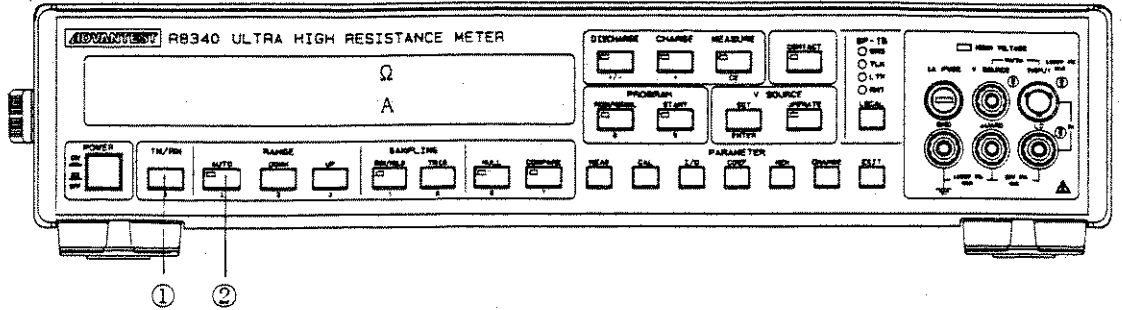

Press ①  I/M/RM to display the ohm mark.

Press ②  AUTO and make sure that the LED goes on.

(3) Setting the Applied Voltage (160V)

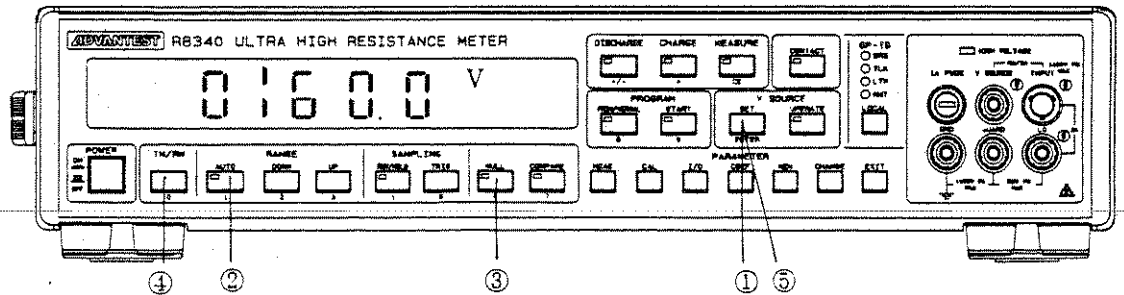

Press ①  SET ②  1 ③  6 ④  0 and ⑤  ENTER to display 0160.0V.

(4) Integral Time Setting

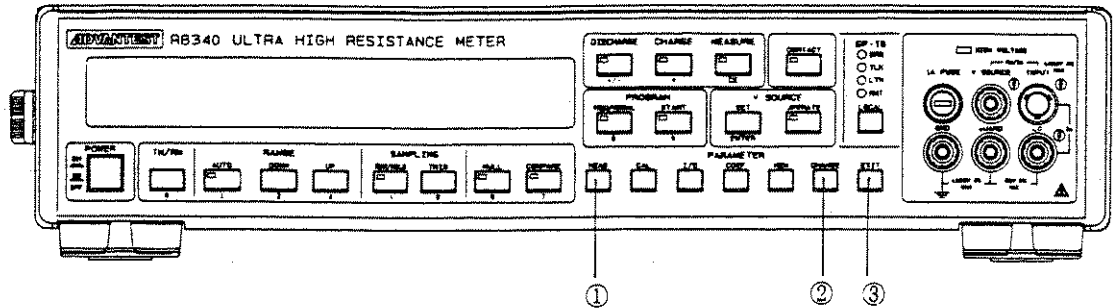

MEAS CHANGE  
Press ①  and ②  to set 10PLC.

EXIT  
Press ③  to cancel or terminate the setting.

(5) Gain Measurement

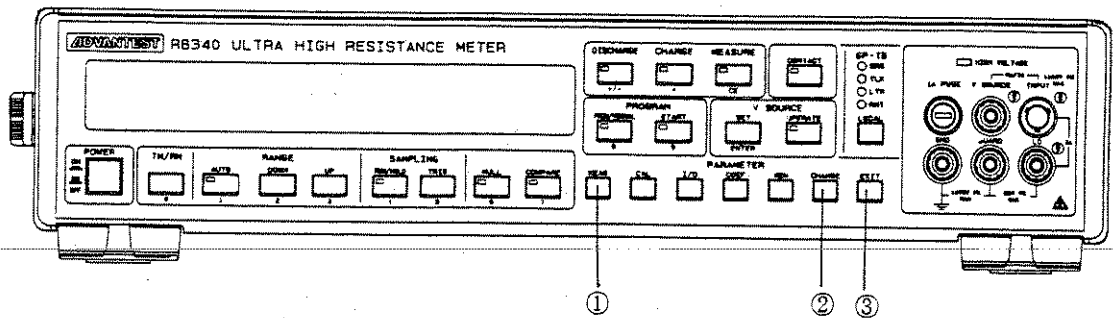

MEAS  
Press ①  three times and set the meter to  $\times 1$  with

CHANGE  
② .

EXIT  
Press ③  to cancel or terminate the setting.

(6) Autorange UP/DOWN Level Setting

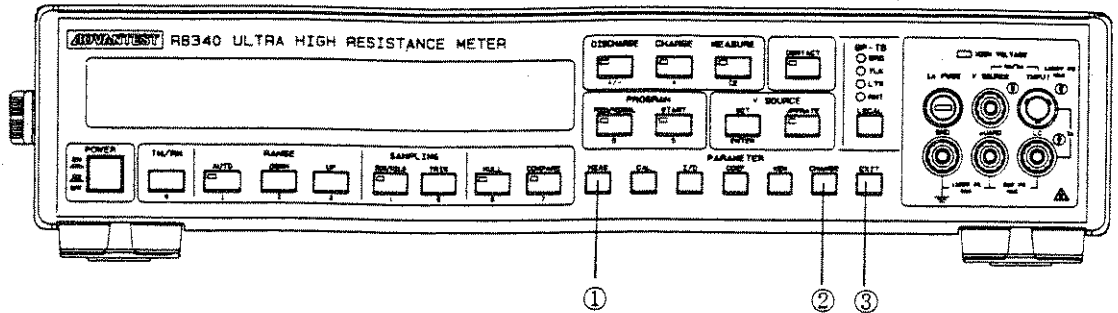

Press ①  MEAS five times and use ②  CHANGE to set 200.

Press ③  EXIT to cancel or terminate the setting.

(7) Autorange Delay Setting

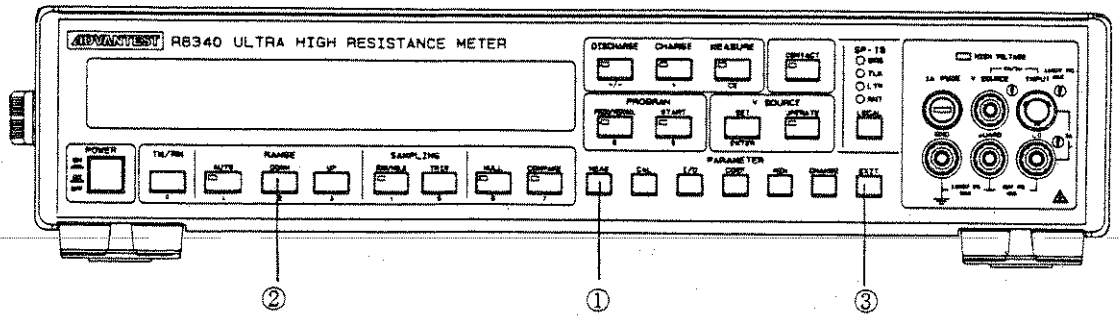

Press ①  MEAS eight times and ②  RANGE.

Press ③  EXIT to cancel or terminate the setting.

(8) Program No. Setting

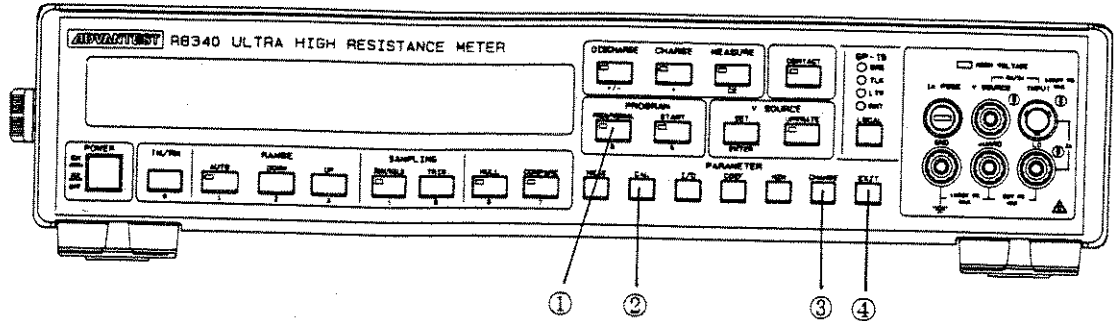

PRGM/NORMAL  
 Press ①  and make sure that the key LED goes on.

CAL CHANGE  
 Press ②  . Use ③  to set 5.

EXIT  
 Press ④  to cancel or terminate the setting.

(9) Charge Time Setting

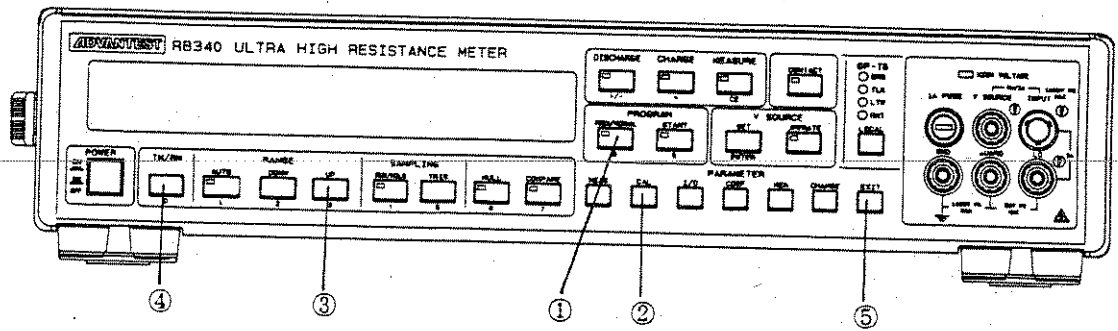

PRGM/NORMAL  
 Press ①  and make sure that the key LED goes on.

CAL EXIT  
 Press ②  twice. Press ③  ④  and ⑤ .

## (10) Discharge Time Setting

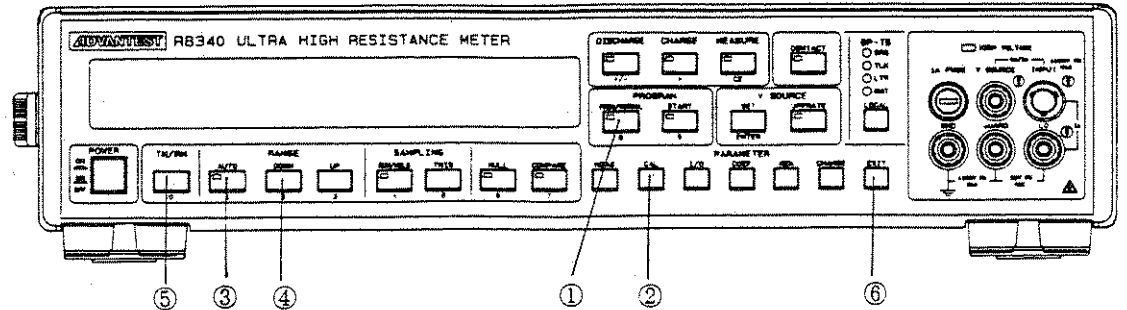

PRGM/NORMAL

Press ①  and make sure that the key LED goes on.

CAL

Press ②  three times.

EXIT

Press ③  ④  ⑤  and ⑥ .

## (11) Setting the Measurement Time

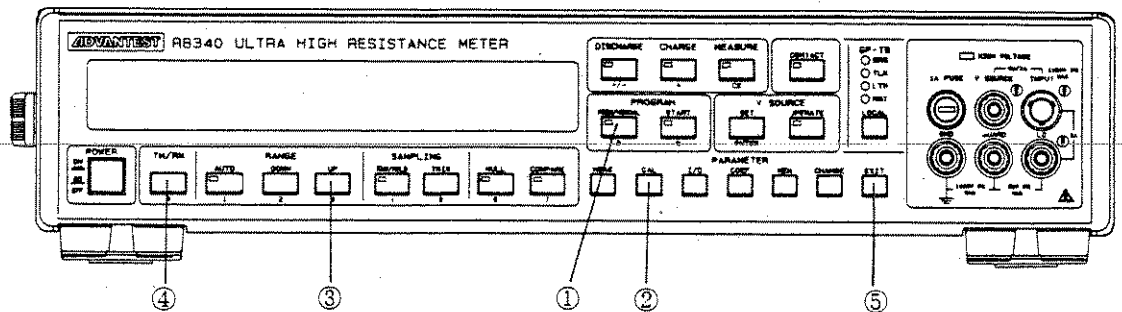

PRGM/NORMAL

Press ①  and make sure that the key LED goes on.

CAL

Press ②  four times, then press ③  ④  and

EXIT

⑤ .



(2) Sequence Program Measurement

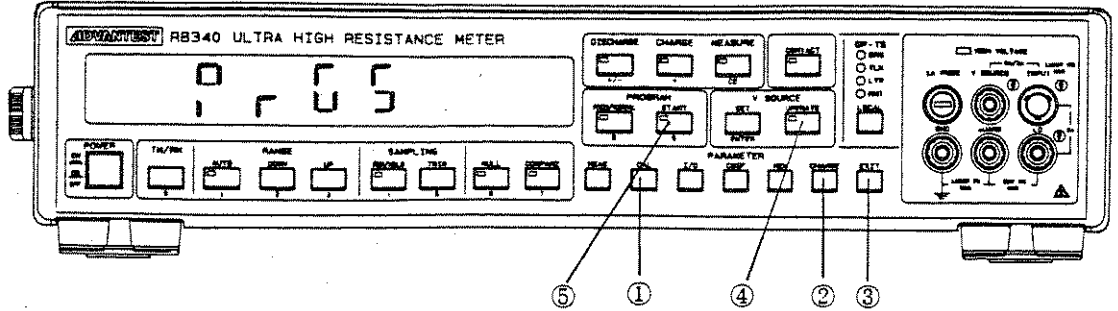

Check that "0.05" is displayed. If not, press ①  and ②  to display "0.05". Then press ③ . Then press ④  and ⑤ .

## 6. GPIB INTERFACE

This section describes control of the meter with the GPIB.

## 6.1 Outline

The GPIB interface is used to connect the meter with the measuring bus based on the IEEE488-1978.

The meter is normally equipped with the GPIB interface, easily configuring a measuring system storing the GPIB using personal computers. Therefore, measurement automation and data processing can be easily realized. Because the remote program through the GPIB can control almost all set items given to the meter panel switch, the interface can correspond to wide applications.

---

6.2 GPIB Standard

Standard used : IEEE Standard 488-1978  
Code used : ASCII code  
Connector pin arrangement :

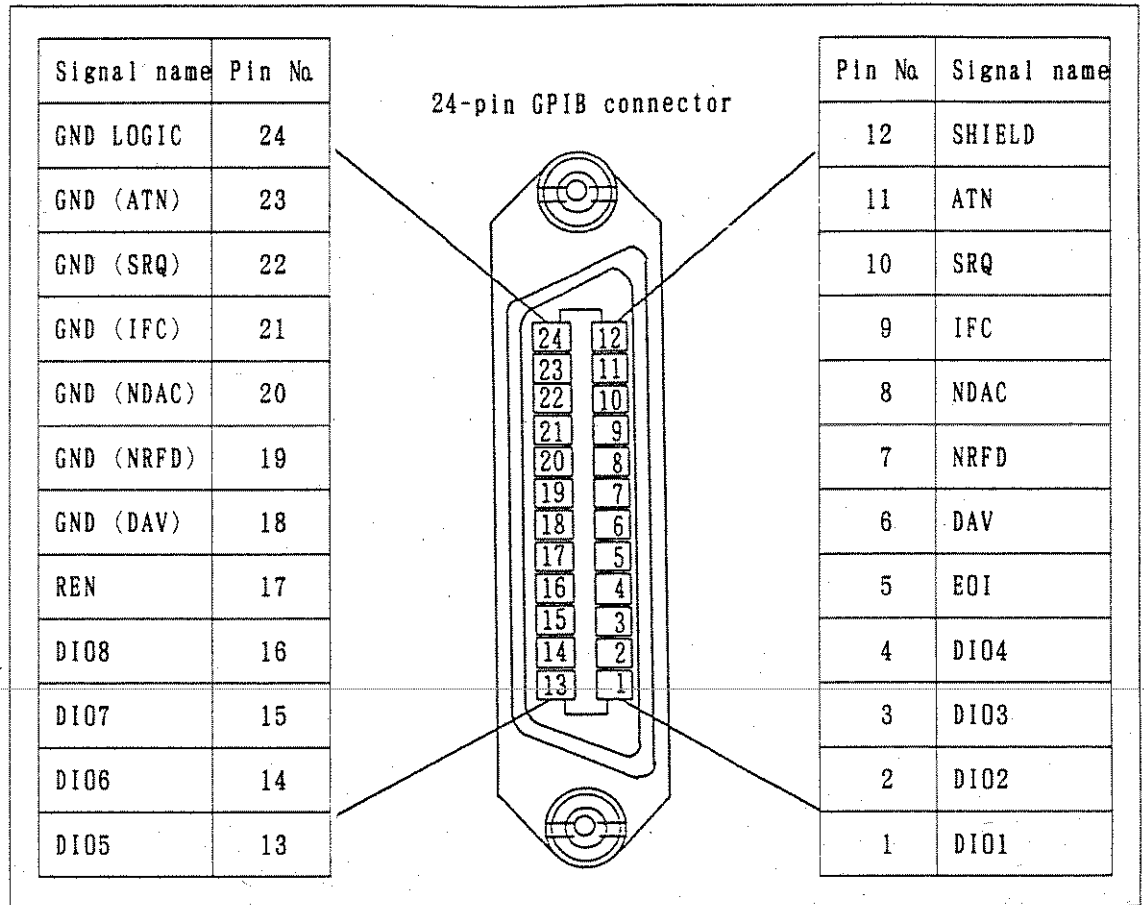

Figure 6 - 1 GPIB Connector Pin Arrangement

Logic level : Logic 0(HIGH state) +2.4V or higher  
Logic 1(Low state) +0.4V or lower  
Signal conductor termination: Sixteen bus lines are terminated as shown in Figure 6-2.

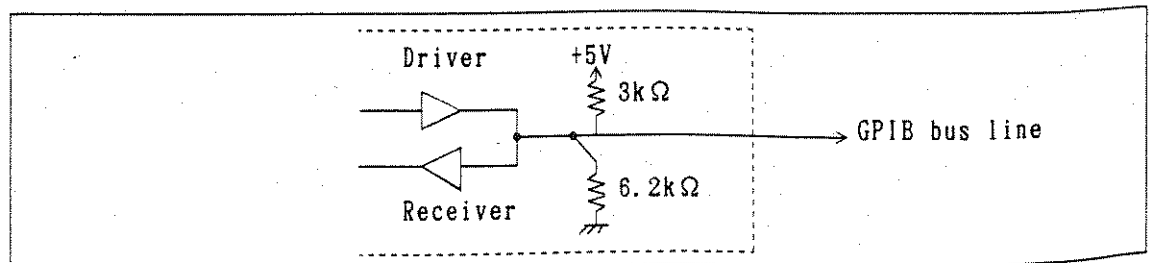

Figure 6 - 2 Signal Conductor Termination

- Driver specification: Tristate system  
 Low-state output voltage: +0.4V or lower 48mA  
 High-state output voltage: +2.4V -5.2mA
- Receiver specification: Low state for +0.6V or lower  
 High state for +2.0V or higher
- Bus cable length : The overall bus cable length should be  
 (number of units connected to bus) × 2m or  
 less and must not exceed 20m.
- Addressing : Talk address and listen address of 31 types  
 can optionally be set according to the GPIB  
 address setting on the front panel.
- Interface function : Table 6-1 shows interfaces and their functions.

Table 6 - 1 Interfaces and Their Functions

Code	Function
SH1	Source handshake function
AH1	Acceptor handshake function
T5	Basic talker function, Talk-only mode function, Serial polling function, Listener-designated talker cancel function
L4	Basic listener function, Talker-designated listener cancel function
SR1	Service request function
RL1	Remote/local changeover function
PPO	With no parallel polling function
DC1	Device clearing function ("SDC" and "DCL" commands can be used.)
DT1	Device trigger function ("GET" command can be used.)
CO	With no controller function
E2	Tristate output

### 6.3 Connection with Component Units

Because the GPIB system consists of several units, configure the system by paying attention to the following points.

Precautions for configuring the system

- (1) Check the condition (preparation) and operation of each unit before connection according to the operation manual of the meter, controller, and peripheral equipment.
- (2) Minimize the length of cables connecting with measuring instruments and bus cables connecting with controllers. Keep the cable length at 20m or less.  
We prepare the cables in Table 6-2 as the standard bus cable.

Table 6 - 2 Standard Bus Cable

Length	Name
0.5m	408JE-1P5
1m	408JE-101
2m	408JE-102
4m	408JE-104

- (3) Bus cable connectors are the piggyback type, which can be used by overlapping them because one connector has a male and female connectors.  
When connecting the bus cables, do not overlap three or more cables. Be sure to secure them with connector setscrews.
- (4) Check the power condition, earthing state, and, if necessary, setting condition of each component unit before turning it on. Be sure to turn on every unit connected to the bus. If any unit is not turned on, the operation of the whole system may not be guaranteed.

#### 6.4 Address Setting and Header on/off Selection

Perform the GPIB talk/listen addressing and header on/off selection with the panel key on the meter. For addressing and header setting, see Item 4.5.3 "GPIB". It is possible to set the header to ON or OFF using an external controller.

## 6.5 Talker Specification (Data Output)

## 6.5.1 Basic Format

## Basic Format

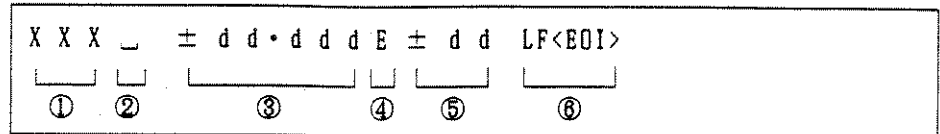

## ① Header

For header OFF, no space is given before the mantissa part of data but data is left-justified.

Three digits (The third digit is a sub-header.)

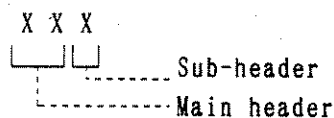

## Main Header

DI: DC measurement  
 RM: Resistance measurement  
 RV: Volume resistivity  
 RS: Surface resistivity

## Sub-header

O : Over-range \*  
 D : Data after NULL operation.  
 H : COMPARE-operation result "HI"  
 G : COMPARE-operation result "GO"  
 L : COMPARE-operation result "LO"  
 E : Measured data error \*  
 M : Data when VS is caught by the current limiter  
 \_ : Cases other than the above

\*:For the above "O" and "E", both data and exponent part are expressed as 99999.99 like D10\_+99.999E+99 because data is incorrect.

The following is the sub-header priority:

High priority                      Low priority  
 O → E → L/G/H → M → D

## ② Space

For header ON, one space is always given after the header.

## ③ Mantissa part data

The polarity "+" or "-" is always given to the top of data. Data consists of a value shown as a decimal point plus four- or five digit number. However, only current measured values are expressed as a four-digit number if the integration time is set to 2ms.



- ④ E  
The character "E" represents an exponent.
- ⑤ Exponent Part Data  
The polarity "+" or "-" is always given to the top of data. Data consists of a value shown as the polarity plus two-digit number according to the unit indication (exponent and symbol). Table 6-3 shows the mantissa- and exponent-part data under each measuring condition.
- ⑥ Block Delimiter  
This can be changed with the program command "DLd" as follows.  
DL0:CRLF (<EOI> (<EOI> simultaneously with L))  
DL1:LF  
DL2:<EOI> simultaneously with the final byte  
DL3:LF<EOI> (<EOI> simultaneously with L)

Table 6 - 3 Mantissa- and Exponent-part Data

	Range	Unit=Symbol (Indication)		Unit=Exponent (Indication)	
		Mantissa part	Exponent part	Mantissa part	Exponent part
Direct current (DI)	200pA	± ddd. dd	-12	± d. dddd	-10
	2nA	± dddd. d	-12	± d. dddd	-09
	20nA	± dd. ddd	-09	± d. dddd	-08
	200nA	± ddd. dd	-09	± d. dddd	-07
	2 μA	± dddd. d	-09	± d. dddd	-06
	20 μA	± dd. ddd	-06	± d. dddd	-05
	200 μA	± ddd. dd	-06	± d. dddd	-04
	2mA	± dddd. d	-06	± d. dddd	-03
	20mA	± dd. ddd	-03	± d. dddd	-02
Resistance measurement (RM RV RS)	One-digit indica- tion	+0000d.	00 to 15	+0000d.	01 to 23
	Two-digit indica- tion	+000dd.	00 to 15	+000d. d	01 to 16
	Three- digit indica- tion	+00dd. d to +00ddd.	00 to 15	+00d. dd	02 to 15
	Four- digit indica- tion	+0dd. dd to +0dddd.	00 to 15	+0d. ddd	03 to 14

When the integration time is set to 2ms, no above least significant digit of current measured data is output.

## 6.5.2 Response to Query Command

### (1) Status Query Response

X X X LF<EOI>

①      ②

- ① For three-digit integer data, the integer data is output with the range between 000 and 255.  
For two-digit integer data, the integer data is output with the range between 010 and 099.  
For one-digit integer data, the integer data is output with the range between 001 and 009.
- ② Terminator  
The terminator is set with the "DLd" command.

### (2) Set Query Response

X X X X X LF<EOI>

①      ②

- ① The response is expressed by alphabetical upper-case and numeric characters. Integer data ranges between -32768 and +32768.
- ② Terminator  
The terminator is set with the "DLd" command.

### (3) Data Query Response

X X X    X X X X , X X X X LF<EOI>

①    ②      ③      ④      ③      ⑤

- ① The response is expressed by alphabetical upper-case characters.
- ② One space is always given.
- ③ Data is expressed as any one of integer data, data with decimal point, and decimal-point data + exponent data.  
The number of data values and data format depend on commands.

- ④ Data Separator  
A comma "," is given.
- ⑤ Terminator  
The terminator is set with the "DLd" command.

### 6.5.3 Binary Packed Format

Binary packed format

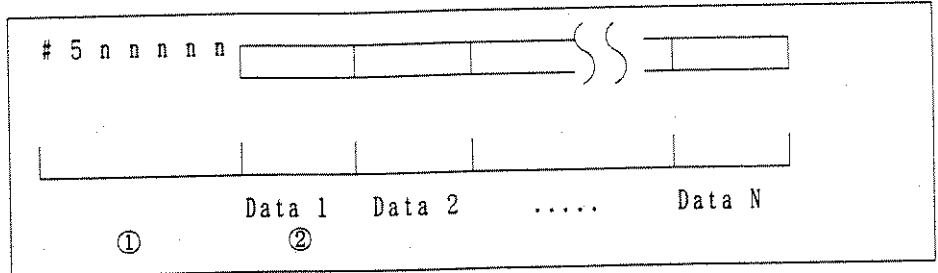

① Preface

This consists of ASCII data and is sent with the following format.

# 5 n n n n n

- Shows 8-bit byte data length. In the above example, a value of 4 x N is given here as a 5-digit ASCII integer because number of data values equals "N" and one data value consists of 4 bytes. 00001 to 99999
- Shows the number of digits of data representing the next data length.
- The sign "#" shows the packed format.

② Data format

Data is sent as 32-bit floating-point notation based on IEEE754-1985.

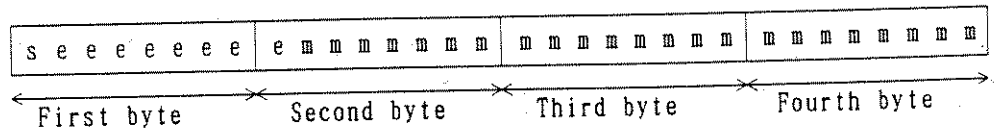

s : Sign bit    0: Positive 1: Negative  
 e : Exponent part of "2" based on 127 (2<sup>0</sup>) 8bit  
 m : Mantissa part 23bit

Where,

1. For e=255 and m≠0: Non-numeric value (Over-range or error data)
2. For e=255 and m=0 : X=-1<sup>e</sup> (∞)
3. For 0<e<255 : X=-1<sup>e</sup> (2<sup>e-127</sup>)(1+m) Normalization
4. For e=0 and m≠0 : X=-1<sup>e</sup> (2<sup>-126</sup>)(0+m) Non-normalization
5. For e=0 and m=0 : X=-1<sup>e</sup> (0) +/- zero

This meter outputs any one of data in Item ①, ③, and ⑤ but does not output data in Item ② or ④. For Item ①, error data such as over-range and operation error is shown. For Item ⑤, the value "-0" is not generated.

Example)

1 0 1 1 1 0 1 1 1 1 0 0 1 0 0 0 0 1 0 0 1 0 0 0 1 0 0 1 0 0 0 0  
 s ← e → m →

In the above case, the exponent and mantissa parts are expressed respectively as follows:

$$\text{Exponent part: } 2^8 + 2^5 + 2^4 + 2^2 + 2^1 + 2^0 = 119 \rightarrow e = 119 - 127 = -8$$

$$\text{Mantissa part: } 2^{-1} + 2^{-4} + 2^{-9} + 2^{-12} + 2^{-16} + 2^{-19} = 0.56471443177$$

$$\rightarrow m = 1 + 0.56471443177 = 1.56471443177$$

$$X = 1.56471443177 \times 2^{-8} = -6.1121657491E-3$$

As for 1, "e" and "m" bits of data are 1.

#### 6.5.4 Format of Recall Data with Data Number

Format of recall data with data number

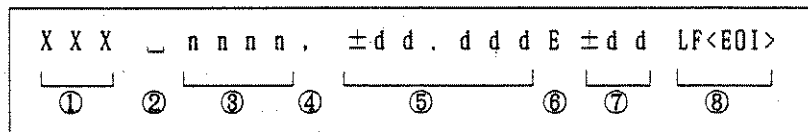

##### ① Header

For header OFF, no space is given before the mantissa part of data but data is left-justified.

Three digits (The third digit is a sub-header.)

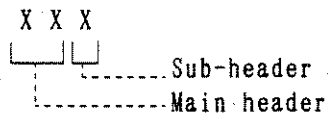

Main header

DI: DC measurement

RM: Resistance measurement

RV: Volume resistivity

RS: Surface resistivity

## Sub-header

O : Over-range \*  
 D : Data after NULL operation  
 H : COMPARE-operation result "HI"  
 G : COMPARE-operation result "GO"  
 L : COMPARE-operation result "LO"  
 E : Measured data error \*  
 M : Data when VS is caught by the current limiter  
 \_ : Cases other than the above

\* : For the above "O" and "E", both data and exponent part are expressed as 99999.99 like D10\_+99.999E+99 because data is incorrect.

The following is the sub-header priority:

Hith priority                      Low priority

O → E → L/G/H → M → D

## ② Space

For header ON, one space is always given after the header.

## ③ Data Number

The number consists of a 4-digit integer between 0001 and 1000.

## ④ Data Separator

A comma "," is given.

## ⑤ Mantissa Part Data

The polarity "+" or "-" is always given to the top of data. Data consists of a value shown as a decimal point plus 5-digit number.

## ⑥ E

The character "E" represents an exponent.

## ⑦ Exponent Part Data

The polarity "+" or "-" is always given to the top of data. Data follows the present unit setting.

Table 6-3 shows the mantissa or exponent-part data under each measuring condition.

## ⑧ Block Delimiter

This can be changed with the program command "DLd" as follows:

DL0:CRLF<EOI> (<EOI> simultaneously with LF)

DL1:LF

DL2:<EOI> simultaneously with the final byte

DL3:LF<EOI> (<EOI> simultaneously with LF)

## 6.6 Listener Specification

The listener command of the meter is roughly divided into the following three types.

### (1) Command Consisting of Only Header

Example) ① Command to designate device parameters such as R10 and R0

② Command to execute measurement and AD CAL function such as \*TRG, ADO, and E

### (2) Command Consisting of "Header + Data"

Example) ① Command to set data such as PVS  $\pm 1.0E+2$  and PHL-199.99E-10

② Command used for setting related to status register such as \*SRE24 and DSE1

### (3) Query Command

Example) RNG?, CNT?, and \*STB?

When the meter receives the above commands, it outputs the response for them to the output buffer.

### 6.6.1 Header Part

#### (1) Space in Header

The space in header results in a syntax error.

Example) ① R1 ..... OK  
R\_1 ..... Syntax error

② \*STB? ..... OK  
\*STB\_ ..... Syntax error

#### (2) One-character Command

Be sure to give the block delimiter after one-character commands "E", "C", and "Z".

Example) AC1ELF<EOI> ..... OK  
AC1EBERR?LF<EOI> ..... Syntax error

### 6.6.2 Data Part

- (1) Separator Between Data  
Be sure to give a comma "," to the separator between data.

Example) PGM\_1, 1.2E-2, 3E-1

- (2) Space in Data  
Among spaces in data, the space in mantissa and exponent data results in a syntax error.

例) PVS\_1.99\_99\_E-1\_2

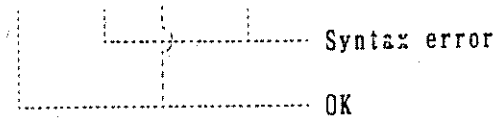

- (3) Data  
Data can be set with NR1 (integer), NR2 (fixed-point data excluding exponents), and NR3 (floating-point data including exponents).

If data with the specified effective number of digits or more is received, the digit one-order lower than the effective digit is rounded to the nearest whole number.

Example) 1.234E-99 → 0  
-1.23456789 → -1.2346

### 6.6.3 Terminator

The block delimiter detects the following:  
LF<EOI>, <EOI>, CRLF, LF,  
CR<EOI>, CRLF<EOI>

### 6.6.4 Query Command

The query command is defined as the command to execute the set parameters, status information, and self-tests and obtain the results of execution. When a query command is received, information corresponding to the command is output to the output buffer. Data is output in the form of NR1, NR2, or NR3. For response data to be output, see the program code in Table 6-4.

Example) ① PVS? (VS set value?)  
→ Response data : PVS\_10.000

② STB? (Status byte?)  
→ Response data : 8



Table 6 - 4 Program Code

Header	Contents	Initial value
RI0	IM (Current measurement)	○
RI1	RM (Resistance measurement)	
RI2	RV (Volume resistivity measurement)	
RI3	RS (Surface resistivity measurement)	
RIX?	The query for the present measurement contents, response is RI0 through RI3.	
R0	AUTO Range	○
R2	200pA Range	
R3	2nA Range	
R4	20nA Range	
R5	200nA Range	
R6	2 $\mu$ A Range	
R7	20 $\mu$ A Range	
R8	200 $\mu$ A Range	
R9	2mA Range	
R10	20mA Range	
RNG?	The query for range, response is R0 and R2 through R10.	
M00	Sampling:RUN	○
M01	Sampling:HOLD	
MOX?	The query for sampling, response is M00 and M01.	
AD0	AD auto calibration:ON	○
AD1	AD auto calibration:OFF	
ADX?	The query for AD auto calibration, response is AD0 and AD1.	
AZ1	Input zero cancel execution	
IT0	Integration time:2mS	
IT1	Integration time:1PLC	
IT2	Integration time:5PLC	
IT3	Integration time:10PLC	○
IT4	Integration time:10PLC $\times$ 4	
IT5	Integration time:10PLC $\times$ 8	
IT6	Integration time:10PLC $\times$ 16	
ITX?	IT Query, response is IT0 through IT6.	

Table 6 - 4 Program Code (Cont'd)

Header	Contents	Initial value
ALO	Auto range level:UP20000 DOWN 1799	○
AL1	Auto range level:UP2000 DOWN 179	
AL2	Auto range level:UP200 DOWN 17	
ALX?	AL Query, response is AL0 through AL2.	
LFO	Power frequency:50Hz	
LF1	Power frequency:60Hz	
LFX?	LF Query, response is LFO and LF1.	
GA0	Input amplifier gain: ×1	
GA1	Input amplifier gain: ×10	○
GA2	Input amplifier gain: ×100	
GA3	Input amplifier gain: ×10000	
GAX?	GA Query, response is GA0 through GA3.	
MDO	MEASURE	○
MD1	CHARGE	
MD2	DISCHARGE	
MDX?	MD Query, response is MDO through MD2.	
OTO	Stand-by	○
OT1	Operate	
OTX?	OT Query, response is OT0 and OT1.	
NMO	NULL operation:OFF	○
NM1	NULL operation:ON	
NMX?	NM Query, response is NMO and NM1.	
RMO	Compare operation:OFF	○
RM1	Compare operation:ON	
RMX?	RM Query, response is RMO and RM1.	
DS0	Indication:ON, Unit indication=Symbol (mA, etc.)	○
DS1	Indication:ON, Unit indication=Exponent ( $\times 10^{-3}$ , etc.)	
DS2	Indication:OFF	
DSX?	DS Query, response is DS0 through DS2.	

Table 6 - 4 Program Code (Cont'd)

Header	Contents	Initial value
BZ0	Buzzer:ON	○
BZ1 BZX?	Buzzer:OFF BZ Query, response is BZ0 and BZ1.	
ST0	Data storage:OFF	○
ST1 STX?	Data storage:ON ST Query, response is ST0 and ST1.	
OM0	Data output mode Basic format Header:ON	○
OM1 OM2 OM3 OM9 OMX?	Data output mode Basic format Header:OFF Data output mode Recall data with data No. Header:ON Data output mode Recall data with data No. Header:OFF Data output mode Binary packed format IEEE754 OM Query, response is OM0 through OM3 and OM9.	
DL0	Block delimiter CRLF<EOI> (<EOI> simultaneously with LF)	○
DL1 DL2 DL3 DLX?	Block delimiter LF Block delimiter <EOI> (<EOI> simultaneously with final byte) Block delimiter LF<EOI> (<EOI> simultaneously with LF) DL Query, response is DL0 through DL3	
S0	SRQ ON	
S1	SRQ OFF	○
SRQ?	S0 and S1 Query, response is S0 and S1.	
IL0	VS current limiter:300mA	○
IL1 IL2 ILX?	VS current limiter:100mA VS current limiter:10mA IL Query, response is IL0 through IL2.	
DA0 DA1 DA2 DA3 DA4 DA5 DA6 DA7 DA8 DAX?	ANALOG OUT (D/A OUT) OFF ANALOG OUT (D/A OUT) ON AAA99 ANALOG OUT (D/A OUT) ON 1AAA9 ANALOG OUT (D/A OUT) ON 19AAA ANALOG OUT (D/A OUT) ON 199AA ANALOG OUT (D/A OUT) ON BBB99 ANALOG OUT (D/A OUT) ON 1BBB9 ANALOG OUT (D/A OUT) ON 19BBB ANALOG OUT (D/A OUT) ON 199BB DA Query, response is DA0 through DA8.	* R8340A only, A syntax error occurs for R8340.

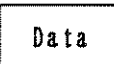







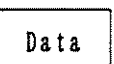

Table 6 - 4 Program Code (Cont'd)

Header	Contents	Initial value
BD0 BD1 BD2 BDX?	BCD OUT OFF BCD OUT BCD BCD OUT BINARY (16bit+10 <sup>a</sup> ) BD Query, response is BD0 through BD2.	* R8340A only. A syntax error occurs for R8340.
CL0 CL1 CL2	Contact checking level:×10 Contact checking level:×5 Contact checking level:×2	
CL3	Contact checking level:×1	○
CL4 CL5 CL6 CLX?	Contact checking level:×0.5 Contact checking level:×0.2 Contact checking level:×0.1 CL Query, response is CL0 through CL6.	
CI1 CI2 CI1?	Contact initialization measurement execution (2ms) Contact initialization measurement execution (1PLC) Contact initialization measurement is executed and outputs the data at initialization (2ms) Response is to 0 to 32767. measurement data	
CI2?	( 0000.0 to 32767(unit : pF) ) ( 99999 at an initial error ) Contact initialization measurement is executed and outputs the data at initialization (1PLC) Response is to 0 to 32767. measurement data ( 0000.0 to 32767(unit : pF) ) ( 99999 at an initial error )	
ABT	Sequence program operation is interrupted.	
	Special command (Terminator is always needed after the command.)	
E	Measurement start and program start. Same with *TRG and GET	
C	Device initialization. Same with SDC and DCL	
Z	Device and parameter initialization. Same with *RST	

CAUTION

The command to interrupt the sequence program operation includes SDC and DCL in addition to ABT. The operation is not interrupted by other commands.

Table 6 - 4 Program Code (Cont'd)

Header	Format	Contents
PVS  PVS?	PVS +dd.dddE ±dd  PVS →  →	Voltage generation data It is allowed to use <NR1>, <NR2> and <NR3> for the data part. PVS Query, response is PVS_XX.XXX
PHL  PHL?	PHL ±hh.hhhE ±hh, ±ll.111E ±ll  PHL →  → , →  →	Compare Upper/Lower setting h :Upper data l :Lower data Error except for h>l It is allowed to use <NR1>, <NR2> and <NR3> for the data part. PHL Query, response is PHL±hh.hhhE ±hh ±ll.111E±ll
PEL  PEL?	PEL 0. tt.tt PEL 1. tt.tt PEL 2. tt.tt.vv.vv, ss.ss  PEL 0. →  →  PEL 1. →  →  PEL 2. →  → , →  → , →  →	50mm-dia-electrode coefficient 70mm-dia-electrode coefficient Optional-electrode coefficient t;Thickness (Unit:mm) v;Volume-resistivity electrode coefficient s;Surface-resistivity electrode coefficient  The previously set value is used when "t", "v", and "s" are omitted. It is allowed to use <NR1>, <NR2>, and <NR3> for the data part.  Response uses <NR1> or <NR2> PEL_d, tt.tt.vv.vv,ss.ss d=0 to 2 There is no omission.
PTD  PTD?	PTD dd.ddd  PTD →  →	Trigger delay It is allowed to use <NR1>, <NR2>, and <NR3> for the data part. PTD Query, response is PTD_dd.ddd.
PAD  PAD?	PAD dd.ddd  PAD →  →	Autoreng delay It is allowed to use <NR1>, <NR2>, and <NR3> for the data part. PAD Query, response is PAD_dd.ddd.

<NR1> : Integer data (Example: +123)  
 <NR2> : Fixed-point data (Example: +12.34)  
 <NR3> : Floating-point data (Example: 123.4E -10)

Table 6 - 4 Program Code (Cont'd)

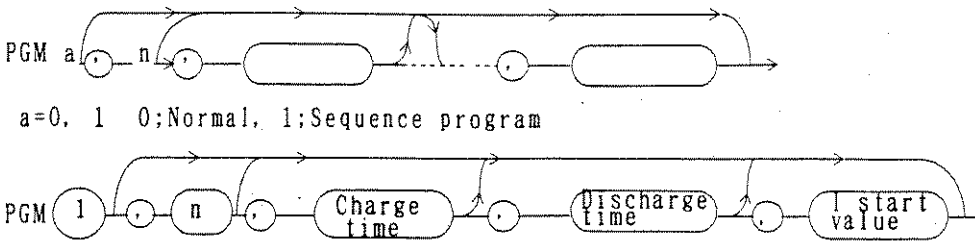
Header	Contents
PGM	 <p>PGM a . n . . . . .</p> <p>a=0, 1 0;Normal, 1;Sequence program</p> <p>PGM 1 . n . Charge time . Discharge time . I start value . . . . .</p> <p>For n=1 to 3 : Charge time and discharge time only            For n=4 : Charge time, discharge time, and I start value            For n=5 : Charge time, discharge time, and measurement time.</p> <p>When the above is omitted, the previously set value is used.</p> <p>Example: PGM1, 4, ., 100E-12</p>
PGM?	<p>The query response for PGM is the same with the PGM command. (No omission)</p> <p>Example: PGM_1, 4, 10, 10, 100E-12</p>
PRE	<p>PRE dddd dddd:1 to 1000 (Data number)            It is allowed to use &lt;NR1&gt;, &lt;NR2&gt;, and &lt;NR3&gt; for the data part.            • Specify the recall data No.            (When the OM2 and OM3 are specified, specify the data to be            output with the command.)</p>
PRE?	<p>The query response for PRE is PRE_ dddd.</p>

**CAUTION**

Program No. 0 of the sequence program cannot be used with GPIB.

Table 6 - 4 Program Code (Cont'd)

Header	Data, Characters in parentheses show response.	Contents (Processing)
CNT?	(0 or 1)	Contact checking is executed and the checking results are output. When the response is "0", checking is OK. If the response is "1", checking is NG.
CNX?	(0 to 32767)	Contact checking is executed and the checking results are output. 0, 0 to 32767 1, 0 to 32767 ..... measurement data ( 0000.0 to 32767 (unit:pF) ) 0 : OK ( at measurement over 99999 ) 1 : NG
DNO?	(0 to 1000)	The number of recall data values in the buffer memory is output. The response is 0 through 1000.
ERR?	(0 to 32767)	The contents of device, execution, and self-test errors are output. The response is output by converting 16-bit error flag into ASCII data. (No error for "0") See Item 6.7.4.
*IDN?	(ASCII Character)	The meter ID is output. ADVANTEST, R8340, 0, 01010101. ..... Maker Model Revision No. name (No serial No.)
*OPT?	(ASCII Character)	Option numbers are output. The value "0" is output when there is no option.
*TST?	(0 to 4095)	The self-test is executed and the results are output. The response is output by converting the error flag into ASCII data. When the value "0" is output, the self-test is OK. See Item 6.7.5.
*TRG		Start of measurement and start of program is specified. GET: Same with the "E" command
*RST		Reset: Same with the "Z" command. The set parameter is initialized. For details, see Section 6.8.

Table 6 - 4 Program Code (Cont'd)

Header	Data, Characters in parentheses show response.	Contents (Processing)
*CLS		Status byte registers other than MAV and the SESR and DESR are cleared, and also the output buffer related to status is cleared.
*SRE	0 to 255	The service request enable register is set. The service request enable register decides the bit of the status register to transmit SRQ.
*SRE?	(0 to 63) (128 to 191)	The contents of the service request enable register are output. Because the RQS bit (bit 6) is not set, the response results in 0 through 63 and 128 through 191.
*STB?	(0 to 255)	The contents of the status register are output. The bit 6 outputs ORed data of all other bits not as the RQS bit but as the MSS bit.
*ESE	0 to 255	The standard event status enable register (SESER) is set. See Item 6.7.2.
*ESE?	(0 to 255)	The contents of the SESER are output. The response is 0 through 255.
*ESR?	(0 to 255)	The contents of the standard event status register (SESR) are output. When the output data is read, the SESR is cleared. The response is 0 through 255. See Item 6.7.2.
DSE	0 to 255	The device event status enable register (DESER) is set. See Item 6.7.3.
DSE?	(0 to 255)	The contents of the DESER are output. The response is 0 through 255.
DSR?	(0 to 255)	The contents of the device event status register (DESER) are output. When the output data is read, the DESER is cleared. The response is 0 through 255. See Item 6.7.3.



Table 6 - 4 Program Code (Cont'd)

Header	Data, Characters in parentheses show response.	Contents (Processing)
*PSC	-32768 to 32767	The power-on clear flag is set or reset. * When PSC is "0", the power-on clear flag is reset. As a result, the service request enable registers SESER and DESER are not cleared when the power is on. * When PSC ranges between 32768 and 32767 (other than 0), the power-on clear flag is set. As a result, the service request enable registers SESER and DESER are cleared when the power is on.
*PSC?	(0 or 1)	The state of the power-on clear flag is output. The power-on clear flag is reset when the response is 0 and set when the response is 1.

#### 6.6.5 Command Buffer and Measured Data Buffer

The meter, in order to shorten the GPIB occupying time, stores program codes in the command buffer under the listener mode and receives the block delimiter before analyzing and executing the stored program codes. During execution of the codes, it is possible to control other units. By setting measured data to "ST1", the data is successively stored in the measured data buffer and the output request is set to the "OM2", "OM3", or "OM9". When the talker mode is specified, data can be transferred in order of measurement.

The buffer size is shown in the table below.

Buffer	Size
Command buffer	256 bytes
Measured data buffer	1000 data value

#### 6.6.6 Controller Interruption During Data Transfer Between Units

The GPIB system makes it possible to transfer data between units other than controllers. When the controller executes interruption to add a new listener during data transfer between units (during handshake), data transfer between units is completed and the priority is given to the interruption by the controller. When the controller changes the mode to the serial polling mode, data transfer between units is interrupted and the priority is given to the interruption by the controller.

## 6.7 Status Byte

### 6.7.1 Structure of Status Byte Register

Figure 6-3 shows the structure of the status byte register. Table 6-5 shows the description of each bit of the register. The contents of the register are read with the serial-polling or \*STB? command. Data in the bit 6 is read as MSS (logic OR of other bits) with the \*STB? command.

Transmission of SRQ is controlled by the service request enable register. The register corresponds to the status byte register in 1 to 1 and SRQ can be transmitted by the bit set to "1". The setting is made with the \*SRE command and the set contents can be read with the \*SRE? command.

Example) When \*SRE1 is set, SRQ is transmitted at the end of measurement.

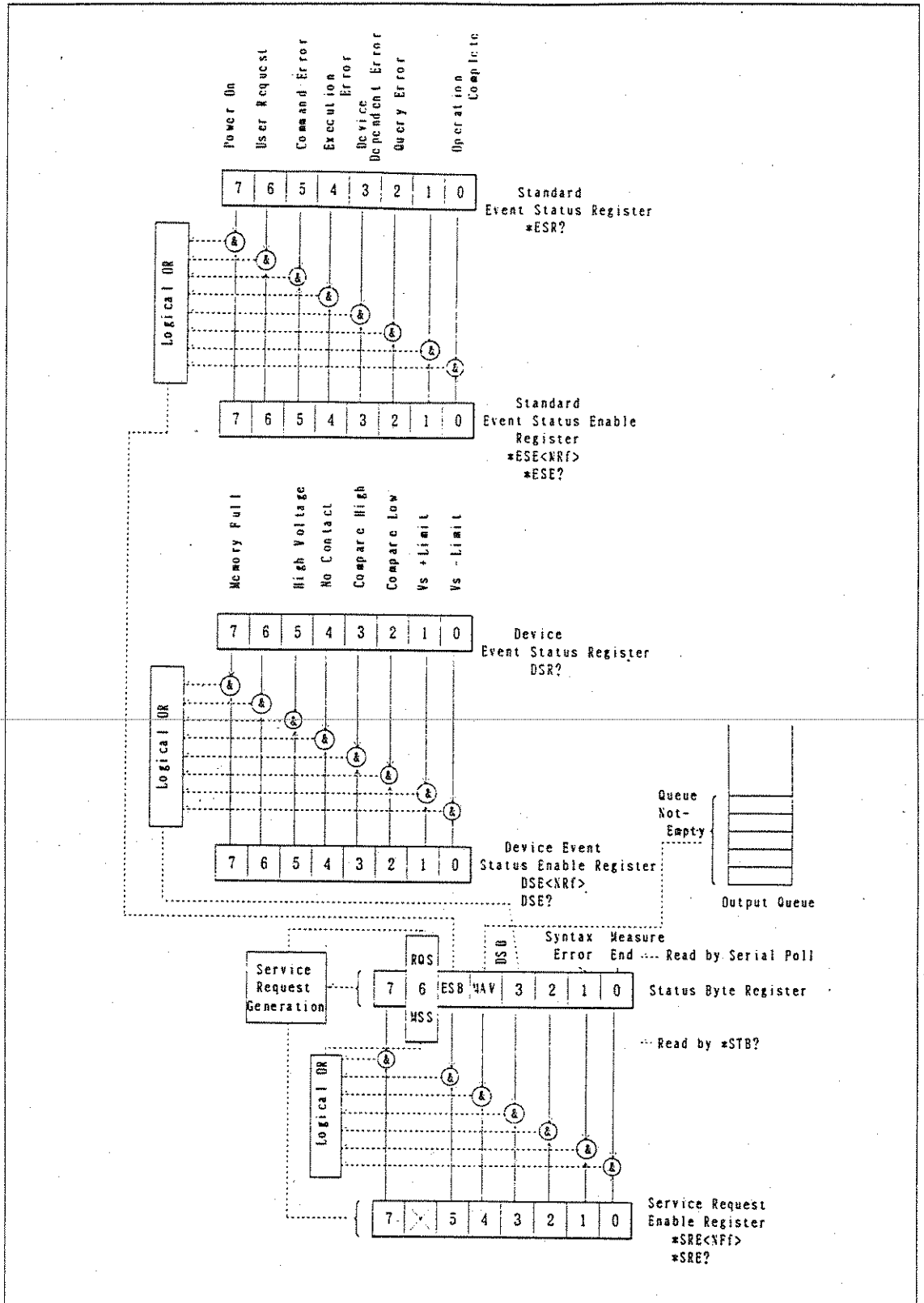

Figure 6 - 3 Structure of Status Byte Register

Table 6 - 5 Status Byte Register

bit	Name	Contents
0	Measure End	This is set at the end of measurement and reset at the start of measurement or end of measured data output.
1	Syntax Error	This is set when the command error (program data error, listener command error, or listener command buffering overflow) occurs.
2	END	This is set when contact checking, contact initialization measurement, and sequence program end.
3	DSB	This is set when a factor of the DESR bit concerned is generated while any one of DESER bits is set to ENABLE and reset when DESER is read. See Item 6.7.3.
4	MAV	This is set when output data is set to the output buffer and reset when output data is read.
5	ESB	This is set when a factor of the SESR bit concerned is generated while any one of SESER bits is set to ENABLE and reset when SESR is read. See Item 6.7.2.
6	RQS(MSS)	This is set when bits 0 through 5 are set.
7	—	Not in use.

CAUTION

1. For the status byte register, only the RQS bit (bit6) is cleared by serial polling.
2. Though the register and output buffer related to status are cleared with the \*CLS command, the measured-data output buffer is not cleared with the command. Therefore, the MAV bit (bit4) is not cleared even if the \*CLS command is received when measured data is present in the output buffer.
3. If the power switch is turned on when the power-on reset flag is set for \*PSC ranging between -32767 and 32768 (other than 0), the status byte enable registers SESER and DESER are cleared but SRQ is not transmitted.

### 6.7.2 Structure of Standard Event Status Register

Figure 6-4 shows the structure of the standard event status register (SESR). Table 6-6 shows the description of each bit of this register. The register is controlled by the standard event status enable register (SESER). When the SESER is set, the bit5 of the status byte register is set if a factor of the bit concerned is generated. In this case, if the bit5 of the status byte enable register is set to ENABLE, the bit6 of the status byte register is set and SRQ is transmitted.

The SESR can be read with the \*ESR? command.

The SESER can be written with the \*ESE command and read with the \*ESE? command.

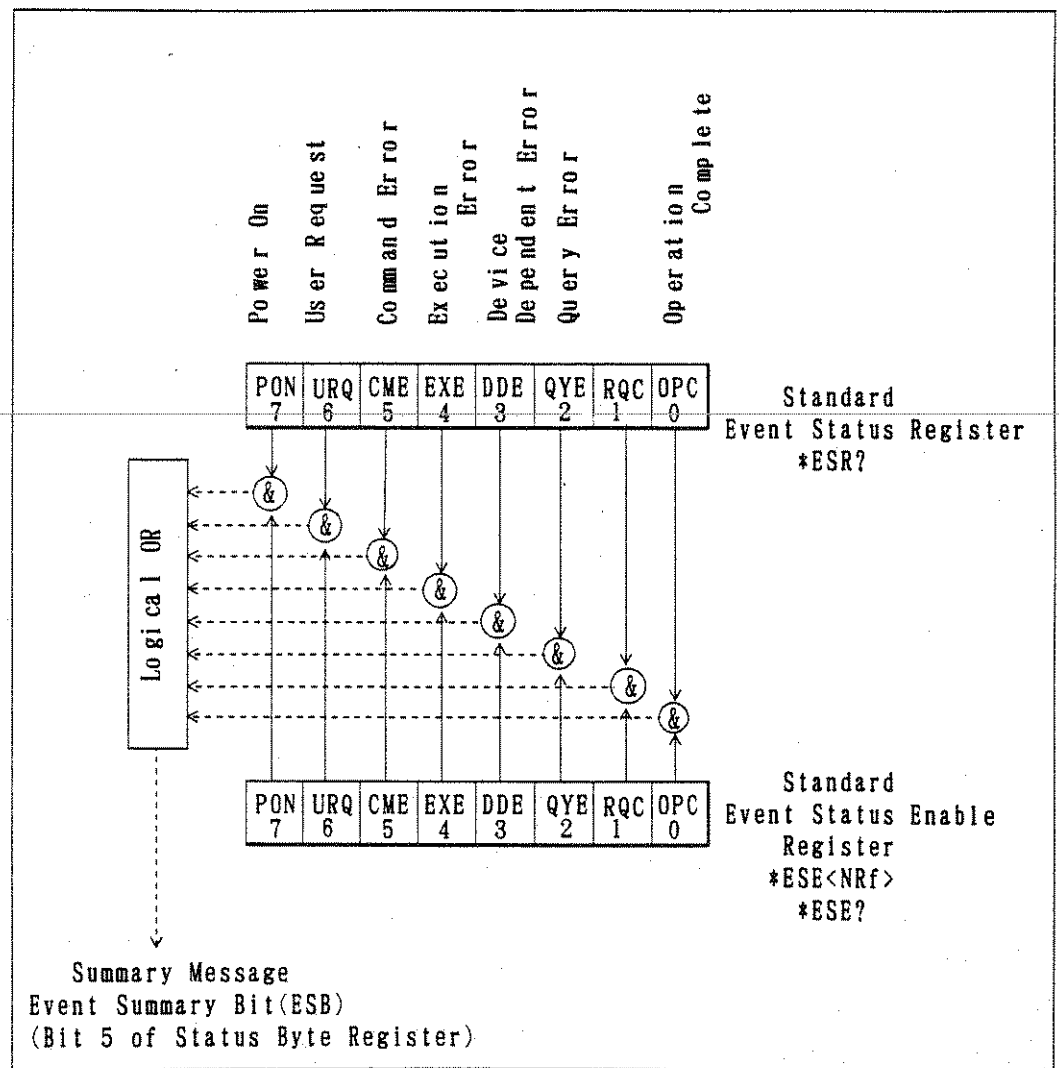

Figure 6 - 4 Standard Event Status Register

Table 6 - 6 Standard Event Status Register

bit	Name	Contents
0	OPC (Operation Complete)	Not in use.
1	RQC	Not in use.
2	QYE (Query Error)	This is set when data is read though no output data is present or the output buffer is overflowed or overloaded.
3	DDE (Device Dependent Error)	This is set when an error occurs during the operation including over-range and overload or a failure occurs.
4	EXE (Execution Error)	This is set when input data is out of the internally set range or a command cannot be executed.
5	CME (Command Error)	This is set when the header is undefined, the data format is incorrect, a syntax error is found in a command, or GET arrives while a command is received.
6	URQ	Not in use.
7	PON (Power On)	This is set when the power is turned on.

### 6.7.3 Structure of Device Event Status Register

Figure 6-5 shows the structure of the device event status register. Table 6-7 shows the description of each bit of this register. The register is controlled by the device event status enable register (DESER). The DESER output is collected in the bit3 of the status byte register.

The DESR is read with the DSR? command.

The DESER is written with the DSE command and read with the DSE? command. The register notifies the condition of internal operation unlike the DDE bit of the SESR which notifies errors.

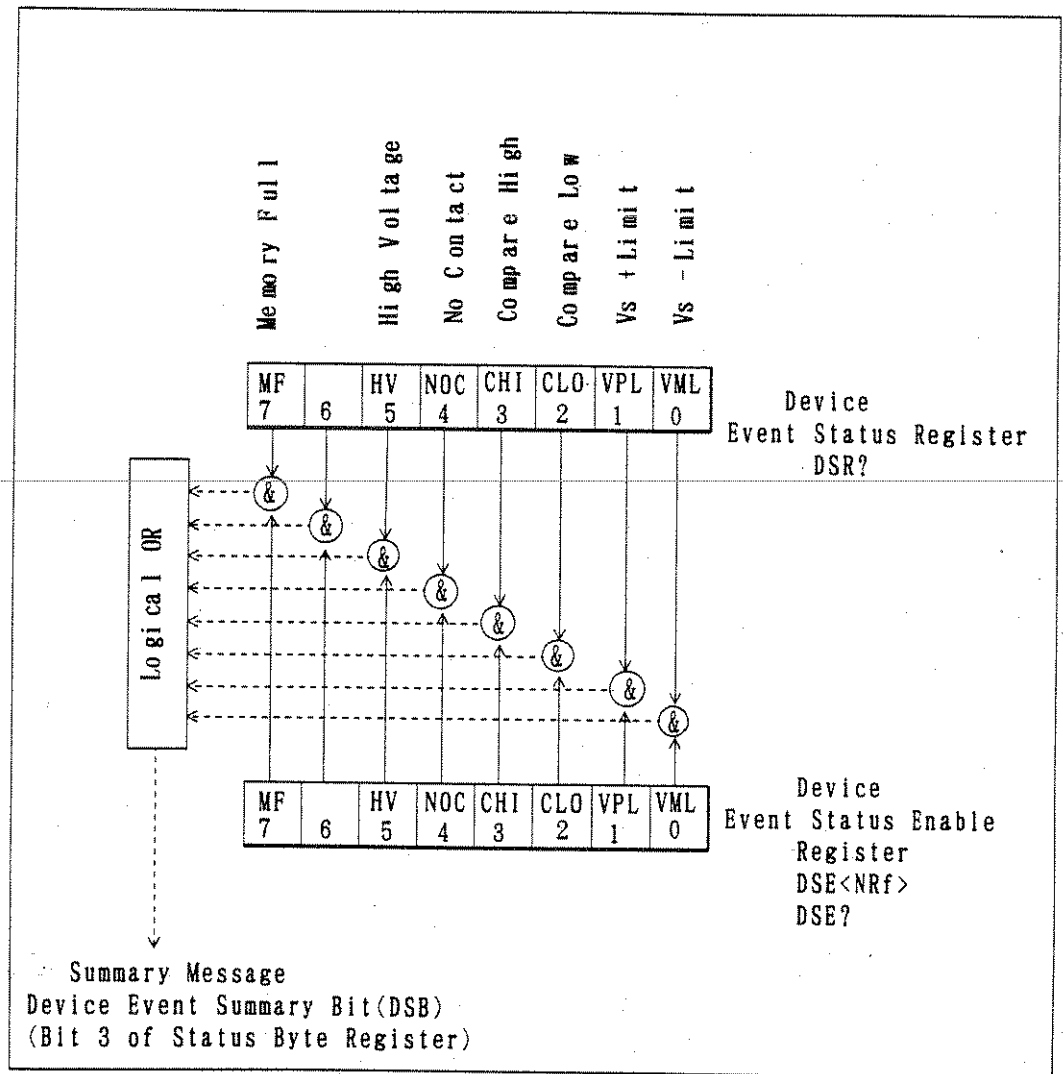

Figure 6 - 5 Device Event Status Register

Table 6 - 7 Device Event Status Register

bit	Name	Contents
0	VML Vs -Limit	This is set when the V-SOURCE negative current limiter (sink limiter) operates.
1	VPL Vs +Limit	This is set when the V-SOURCE positive current limiter (source limiter) operates.
2	CLO Compare Low	This is set when LO is judged as the result of COMPARE operation.
3	CHI Compare High	This is set when HI is judged as the result of COMPARE operation.
4	NOC No Contact	This is set when NG (imperfect contact) is detected as the result of contact checking.
5	HV High Voltage	This is set when V SOURCE is set to 100V or more or 100V or more is applied to the V-SOURCE terminal.
6	—	Not in use.
7	MF Memory Full	This is set when the data buffer memory is full (1000 data values).



### 6.7.4 Error Register

The contents of the internal error register is output as the response of the ERR? command. This register consists of 16 bits and each bit is as shown in Table 6-8. The ERR? command response is output as data value between 0 and 32767 by converting the error register contents into ASCII data.

Table 6 - 8 Error Register

bit	Set bit of SESR		Error contents	Error Indication
	Name	bit		
0	EXE	bit4	Vs is set to zero for RM measurement.	VERR
1	EXE	bit4	Contact checking cannot be judged.	ERROR
2	EXE	bit4	Contact initialization cannot be checked.	C. INIT ERROR
3	QYE	bit2	Recall is executed when there is no output data.	—
4	CME	bit5	Program data format error	—
5			Listener command error.	—
6			Listener command input buffer overflow	—
7	DDE	bit3	Over-range	OL
8			Overload	OVL
9			Operation error	ERR 5
10			Overvoltage detection	OVER VIN
11			Input fuse melting	FUSE OPEN
12			Overheat	OVER HEAT
13			Internal serial transfer error	ERR4
14			Self-test error	See Table 6-9.
15	—	—	Not in use	—

### 6.7.5 Self-test Error Register

As the response of the \*TST? command, the contents of the 16-bit self-test error register are converted into ASCII data and output as the data values between 0 and 4095. When an error is detected in the self-test, the bit 3 DDE of the SESR is set. When the response is "0", the self-test is OK.

Table 6 - 9 Self-test Error Register

bit	Error contents	Error Indication
0	Defect of input amplifier	ERR IA
1	Defect of AD converter	ERR AD
2	Defect of 100V amplifier	ERR HV
3	Defect of 1000V amplifier	ERR KV
4	Serial transfer error	ERR 4
5	Breakdown of calibration primary data	ERR 2
6	Breakdown of calibration secondary data	ERR 3
7	Breakdown of backup parameter (Panel backup, etc.)	ERR 1
8	RAM read/write error	ERR RA
9	E <sup>2</sup> PROM read/write error	ERR EP
10	Logic ROM error	ERR LR
11	Analog ROM error	ERR AR
12	Not in use	
13	Not in use	
14	Not in use	
15	Not in use	

## 6.8 Status at Initialization and Command Reception

Table 6 - 10 Status Change by Each Command

Command	Talker (TLK)	Liste- ner (LTN)	SRQ (RQS bit)	Status byte SESR DESR	SRQ enable SESER DESER	Data output buffer	Set parameter
Power On	Clear	Clear	By power -on clear flag	Bits other than PON bit are cleared.	By power -on clear flag	Clear	#1
"*RST" "Z "	/	/	/	/	/	/	Initial- ization
DCL, SDC "C "	/	/	/	Only MAV bit is cleared.	/	Clear	/
IFC	Clear	Clear	/	/	/	/	/
"*CLS "	/	/	By MAV bit	Bits other than MAV bit are cleared.	/	/	/
GET, "E " "*TRG "	/	/	/	Measure end bit is cleared.	/	/	/
Talker designation	Set	Clear	/	/	/	/	/
Talker cancel designation	Clear	/	/	/	/	/	/
Listener designation	Clear	Set	/	/	/	/	/
Listener cancel designation	/	Clear	/	/	/	/	/
Serial polling	/	/	Clear	/	/	/	/

DCL : Device Clear

SDC : Selected Device Clear

GET : Group Execute Trigger

#1 : When pressing the auto key immediately after the power is on,  
the parameter is initialized.

## 6.9 Program Example

The following shows the program using HP-9816 for a personal computer and its description.

In the above program examples, the address of the meter is set to "1".

- Example of charging the insulation resistance of a sample for 10ms before measuring the resistance and outputting the measurement results. .... See (1)
- Example of judging the insulation resistance of a sample with a comparator when executing contact checking and starting measurement with external trigger signal. .... See (2)
- Example of dielectric strength test on a transistor. .... See (3)

- (1) Example of charging the insulation resistance of a sample for 10ms before measuring the resistance and outputting the measurement results

Measurement condition ..... Vs:100V, Charge time:10ms

• Program example1

```

10  !
20  !      EXAMPLE 1
30  !
40  DIM A$(20)
50  CLEAR 701
60  !
70  OUTPUT 701;"R11, R0, M01"
80  OUTPUT 701;"ITO, GA1, ALO"
90  OUTPUT 701;"PVS100"
100 !
110 OUTPUT 701;"MD2"
120 OUTPUT 701;"OT1"
130 OUTPUT 701;"MD1"
140 WAIT .01
150 OUTPUT 701;"MDO"
160 !
170 TRIGGER 701
180 ENTER 701:A$
190 PRINT A$
200 END
  
```

• Data example

```

RM 010.09E+09
  
```

• Description of program example1

Line number	Description
10 to 30	Comment sentence
40	Reserving the measured data area
50	Initializing the GPIB interface device
70 to 90	Setting the meter parameter
	"R11" ..... Resistance measurement
	"R0" ..... Auto range
	"MO1" ..... Sampling:HOLD
	"ITO" ..... Integration time:2ms
	"GA1" ..... Input amplifier gain: ×10
	"ALO" ..... Auto range level:20000
	"PVS100" ..... VS100V
100	Comment sentence
110	Setting the discharge state
120	Setting the operation state
130	Setting the discharge state
140	Waiting for 10ms
150	Setting the measurement state
160	Comment sentence
170	Starting the measurement
180	Receiving the data
190	Displaying the data
200	Ending the program

- (2) Example of judging the insulation resistance of a sample with a comparator when executing contact checking and starting measurement with external trigger signal

Criterion: The case of  $1 \times 10^7 \Omega \leq RX \leq 1 \times 10^{12} \Omega$  is judged as pass.

• Program example2

• Data example

```

10      !
20      !      EXAMPLE 2
30      !
40      !
50      ON INTR 7 GOSUB Srq
60      CLEAR 701
70      OUTPUT 701: "*CLS"
80      OUTPUT 701: "SO, RI1, RO, MO1"
90      OUTPUT 701: "ITO, GA1, AL1, RM1"
100     OUTPUT 701: "PVS50, PHL1E+12, 1E+7"
110     OUTPUT 701: "*SRE24, DSE12"
120     !
130     OUTPUT 701: "MD2"
140     OUTPUT 701: "OT1"
150     OUTPUT 701: "MD1"
160     WAIT .01
170     OUTPUT 701: "MDO"
180     !
190     OUTPUT 701: "CNT?"
200     ENTER 701;B
210     IF B=1 THEN 240
220     K$="CONTACT"
230     GOTO 250
240     K$="NO-CONTACT"
250     !
260     ENABLE INTR 7;2
270     !
280     !      EXT TRIGGER WAIT
290     !
300     GOTO 300
310 Srq: !
320     S=SPOLL(701)
325     ENTER 701;D$
330     IF BIT(S,3)=0 THEN 410
340     OUTPUT 701: "DSR?"
350     ENTER 701;A
360     IF BIT(A,2)=1 THEN 390
365     IF BIT(A,3)=0 THEN 410
370     L$="HIGH"
380     GOTO 415
390     L$="LOW"
400     GOTO 415
410     L$="GO"
415     PRINT D$, K$, L$
420     ENABLE INTR 7;2
430     RETURN
440     END

```

```

RMH +0008.9E+09
CONTACT
HIGH

```

• Description of program example2

Line number	Description
10 to 40	Comment sentence
50	Defining the interrupt processing routine
60	Initializing the GPIB interface device
70	Clearing the status byte register
80 to 110	Setting the meter parameter
	"SO" ..... Transmitting SRQ
	"RI1" ..... Resistance measurement
	"RO" ..... Auto range
	"MO1" ..... Smpling:HOLD
	"ITO" ..... Integration time:2ms
	"GA1" ..... Input amplifier gain: ×10
	"AL1" ..... Auto range level:2000
	"RM1" ..... COMPARE operation ON
	"PVS50" ..... VS50V
	"PHL1E+12, 1E+7" ..... Upper limit value:1×10 <sup>12</sup> Ω, Lower limit value:1×10 <sup>7</sup> Ω,
	"*SRE24" ..... Setting the service request enable register to "24"
	"DSE12" ..... Setting the device event status enable register to "12"
120	Comment sentence
130	Setting the discharge state
140	Setting the operation state
150	Setting the charge state
160	Waiting for 10ms
170	Setting the measurement state
180	Comment sentence
190	Executing the contact checking
200	Receiving the contact checking result data
210	Branching to the line number 240 if the result data is "1" (NG)
220	Saving the "CONTACT" indication
230	Branching to the line number 250
240	Saving the "NO-CONTACT" indication
250	Comment sentence
260	Enabling the interrupt form the GPIB
270 to 290	Comment sentence
300	Waiting for the external trigger to be applied at the line number 300
310	Interrupt processing routine name
320	Reading the status byte by polling the meter
325	Receiving measured data
330	Branching to the line number 410 if the bit 3 of the status byte is "0"
340	Executing the read command of the device event register

• Description of program example2 (Continued)

Line number	Description
350	Reading the device event register
360	Branching to the line number 390 if data bit 2 is "1"
365	Branching to the line number 410 if the data bit 3 is "0"
370	Saving the "HIGH" indication
380	Branching to the line number 415
390	Saving the "LOW" indication
400	Branching to the line number 415
410	Saving the "GO" indication
415	Displaying the measured data, and results of contact checking and COMPARE operation
420	Enabling the interrupt from the GPIB
430	Returning to the main processing routine
440	Ending the program



(3) Example of Dielectric Strength Test on a Transistor

The current at puncture is set to 100  $\mu$ A and generated voltage is read when the applied voltage is increased 1V by 1V starting with 101V and the current exceeds 100  $\mu$ A.

• Program example3

• Data example

```

10  !
20  !      EXAMPLE 3
30  !
40  DIM A$(20)
50  CLEAR 701
60  !
70  OUTPUT 701;"S1, RIO, RO, MO1"
80  OUTPUT 701;"IT1, GA3, ALO, RM1"
90  OUTPUT 701;"PHL100E-6, 0E-12"
100 OUTPUT 701;"*SRE9, DSE8"
110 !
120 OUTPUT 701;"MD2"
125 OUTPUT 701;"PVSO"
130 OUTPUT 701;"OT1"
140 OUTPUT 701;"MD1"
150 WAIT .01
160 OUTPUT 701;"MDO"
170 OUTPUT 701;"*CLS"
180 Vs-data=101
190 OUTPUT 701;"PVS";Vs-data
200 TRIGGER 701
210 S=SPOLL(701)
220 IF BIT(S,0)=0 THEN 210
230 IF BIT(S,3)=1 THEN 270
240 Vs-data=Vs-data+1
245 IF Vs-data=1001 THEN 295
250 GOTO 190
260 !
270 OUTPUT      "PVS?"
280 ENTER 701;A$
290 PRINT A$
295 OUTPUT 701;"OTO"
300 END
  
```

PVS 0205.0

• Description of program example3

Line number	Description
10 to 30	Comment sentence
40	Reserving the data area
50	Initializing the GPIB interface device
60	Comment sentence
70 to 100	Setting the meter parameter
	"S1" ..... SRQ stop
	"R10" ..... Current measurement
	"R0" ..... Auto range
	"MO1" ..... Sampling:HOLD
	"IT1" ..... Integration time:1PLC
	"GAS" ..... Input amplifier gain: ×10000
	"ALO" ..... Auto range level:20000
	"RM1" ..... COMPARE operation ON
	"PHL100E-6, 0E-12"
	..... Upper limit value:100 μA
	..... Lower limit value:0 pA
	"*SRE9" ..... Setting the service request enable register to "9"
	"DSE8" ..... Setting the device event status enable register to "8"
110	Comment sentence
120	Setting the discharge state
125	Setting the VS data to 0V
130	Setting the operation state
140	Setting the charge state
150	Waiting for 10ms
160	Setting the measurement state
170	Clearing the status byte register
180	Setting the initial value (101V) of VS data variable
190	Setting the VS data
200	Starting the measurement
210	Polling the meter to read the status byte
220	Branching to the line number 210 if the bit 0 of the status byte is "0"
230	Branching to the line number 270 if the bit 3 of the status byte is "1"
240	Adding "1" to the VS data variable data
245	Branching to the line number 295 when VS data is set up to 1000V
250	Branching to the line number 190
260	Comment sentence
270	Executing the command to read VS data
280	Receiving the VS set data
290	Displaying the data
295	Setting the stand-by state
300	Ending the program

## 7. INPUT/OUTPUT SIGNALS

The meter has the input/output signals for control shown below.

- Handler interface
- COMPLETE output signal
- TRIGGER input signal
- LID SIGNAL input signal

The following describes the above signals in order.

### 7.1 Handler Interface

The handler interface is the input/output signals to control the timing with the automatic equipment in the capacitor manufacturing line and external equipment including the auto prober and fixture.

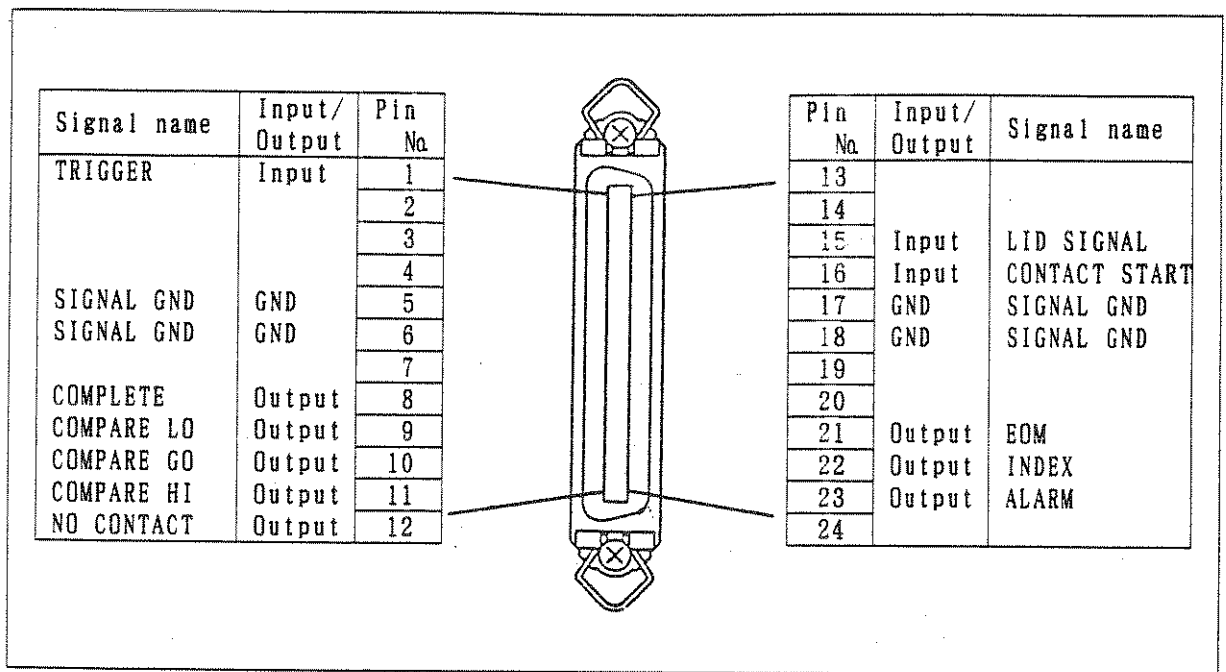

Figure 7 - 1 Description of Handler Interface Connector Pins

- (1) Connector used (Equivalent of DAIICHI DENSHIKOGYO Product)  
 R8340/8340A body side:57-40240  
 Connection cable side:57-30240

(2) Signal Level

The input/output signals are set to the TTL (equivalent of SN74LS series) level.

Negative logic (Active low)

HI level : +2.7V to 5.25V (Output signal)  
          +3.2V to 5.25V (Input signal)

LO level : 0 to 0.6V (Output signal)  
          0 to 0.5V (Input signal)

The output signal is equivalent to the SN74LS07N product and pulled up to 5V inside the open collector.

- ① TRIGGER Input : Measurement start signal  
Pulse width : 100  $\mu$ S or more (Operated at the fall of pulse)  
Chattering : 5ms or less
- ② CONTACT START Input : Contract-checking start signal  
Pulse width : 100  $\mu$ S or more (Operated at the fall of pulse)  
Chattering : 5ms or less
- ③ COMPLETE Output : Negative pulse signal is output when measurement operation ends and data can be output.  
Pulse width : Approx. 500  $\mu$ S (Negative pulse)
- ④ LID SIGNAL : Lid operating signal  
Operated as shown in Figure 7-2.

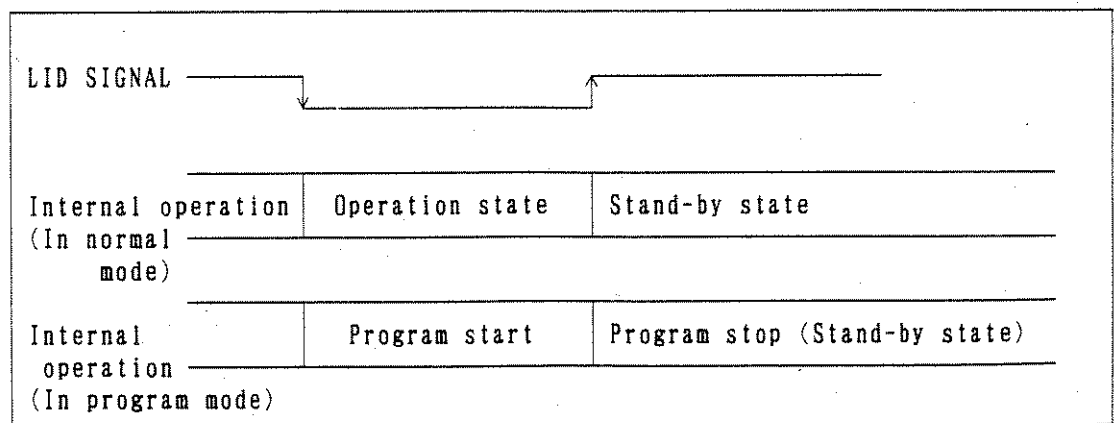

Figure 7 - 2 LID SIGNAL Timing

⑤ Other Output Signals

- COMPARE LO, GO, HI : As the result of comparator operation, any one of LO, GO, and HI signals becomes low level.
- NO CONTACT : As the result of contact checking, the signal becomes low level for judgment of imperfect contact.
- INDEX : Shows minimum time necessary for measurement. The signal becomes low level after completion of measurement.
- EOM(End Of Measure) : Becomes low level after completion of measurement operation. (The signal is output at the same timing with COMPLETE.)
- ALARM : Becomes low level for internal trouble or breakdown.

(3) Handler Interface Timing

① At Start of Measurement

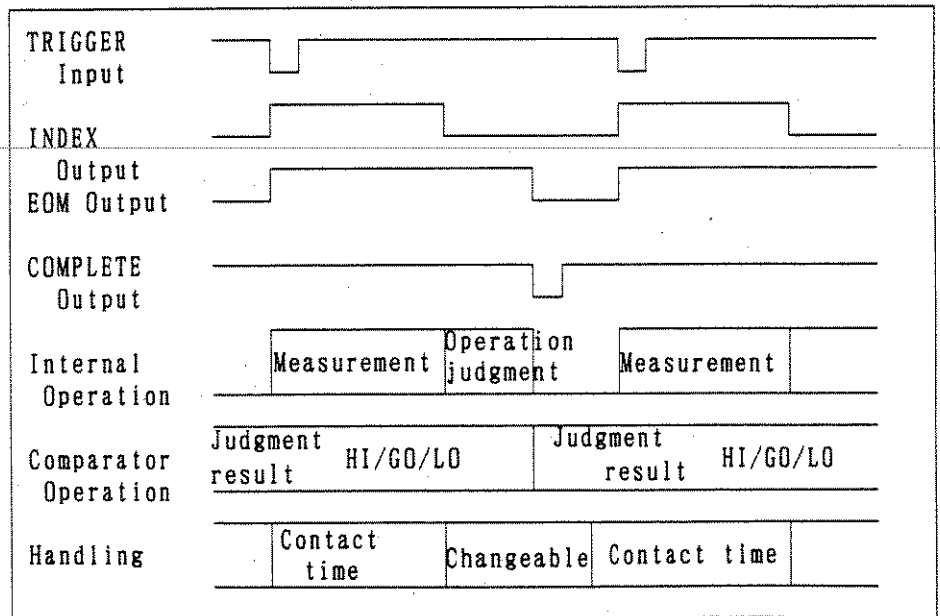

Figure 7 - 3 Handler Interface Timing

② At Start of Contact Checking

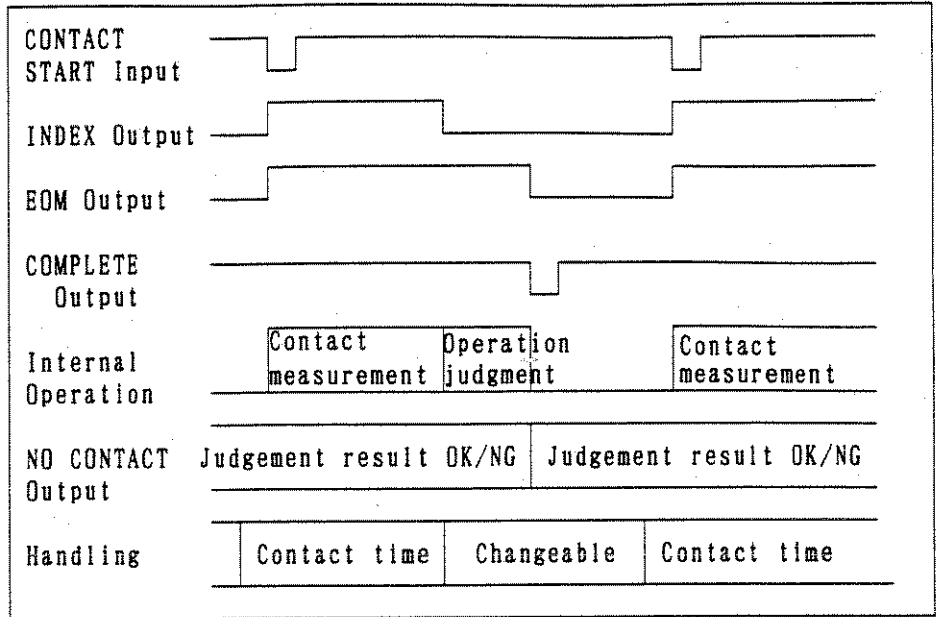

Figure 7 - 3 Handler Interface Timing (Cont'd)

- ③ When start of contact checking is detected during measurement.  
 (Measurement is interrupted.)

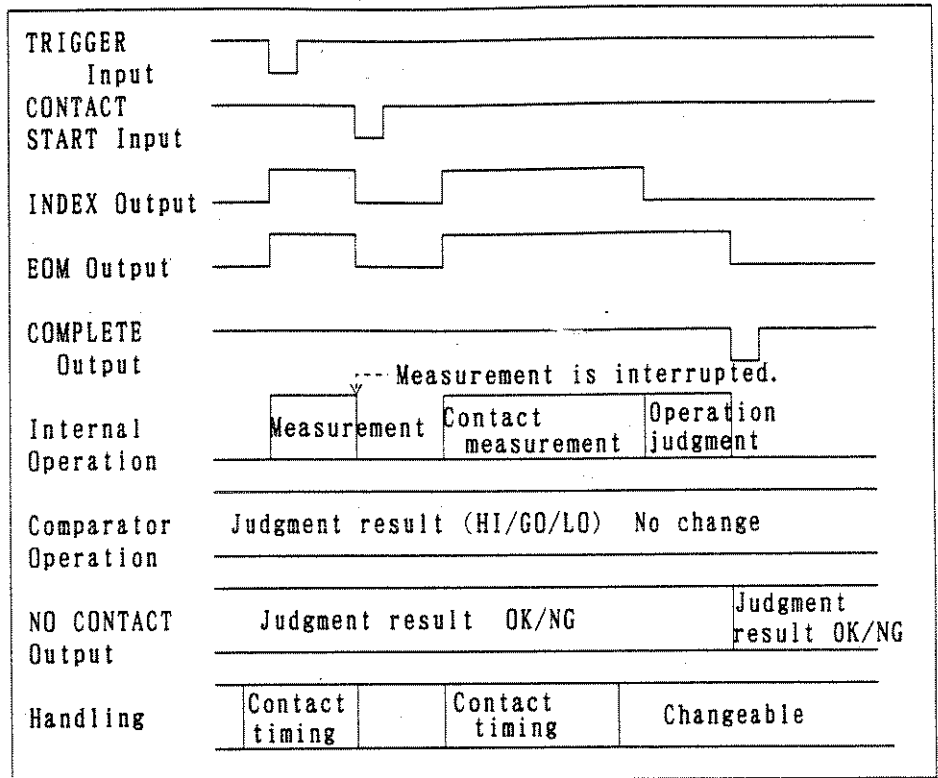

Figure 7 - 3 Handler Interface Timing (Cont'd)



④ When start of measurement is detected during contact checking.

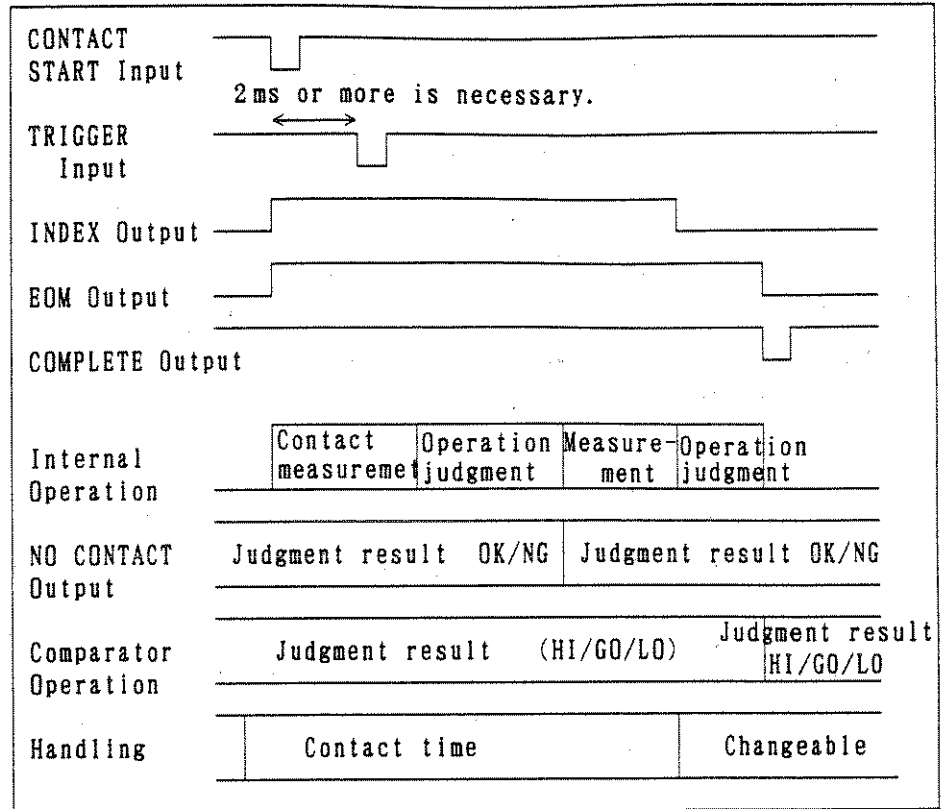

Figure 7 - 3 Handler Interface Timing (Cont'd)

- ⑤ When measurement start and contact checking are simultaneously detected.  
 (Only in this case, contact checking is executed after measurement.)

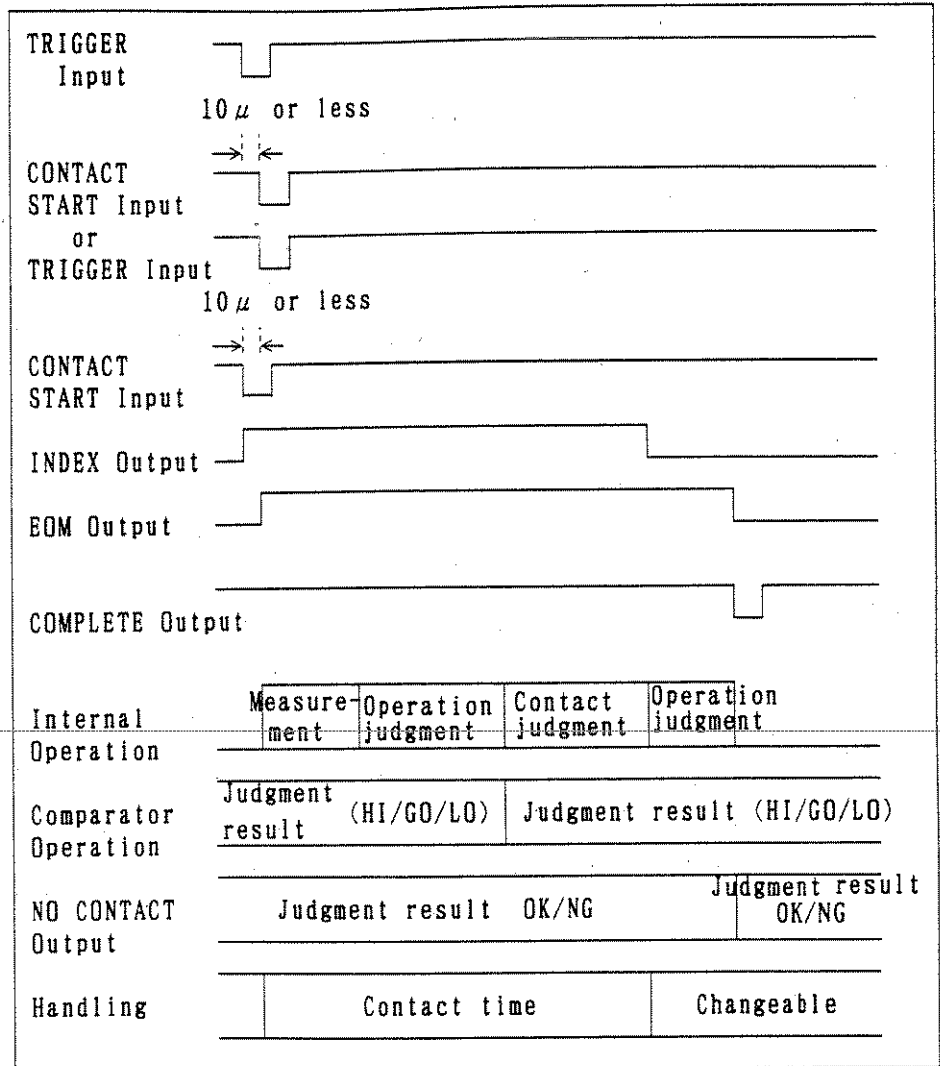

Figure 7 - 3 Handler Interface Timing (Cont'd)

## 7.2 COMPLETE Output Signal

The COMPLETE output signal is the output signal to notify end of measurement to the outside. The signal is also output at the end of one cycle for program measurement.

The output signal is set to the TTL (equivalent of SN74LS07N) level, which is the negative pulse signal with open collector output.

HI level : +2.7 to +5.25V 400  $\mu$ A max.  
LO level : 0 to +0.6V -5mA max.  
Pulse width : Approx. 500  $\mu$ s (Negative pulse)

### 7.3 TRIGGER Input Signal

The TRIGGER input signal is the input signal to externally start measurement, which also makes it possible to start program measurement. After measurement starts, the signal is effective when SAMPLING on the front panel of the meter is set to HOLD. The input signal is the negative pulse and starts the sampling at the trailing edge.

HI level : +3.2 to +5.25V  
LO level : 0 to +0.5V  
Pulse width : 100  $\mu$ s or more (Operated at the fall of pulse)  
Chattering : 5ms or less

## 7.4 LID SIGNAL Input Signal

The LID SIGNAL input signal is the input signal to operate the fixture lid. The signal controls the operation/stand-by states in the normal measurement mode and the program start/stop in the program mode.

Figure 7-2 shows the LID SIGNAL timing.

HI level : +3.2 to +5.25V

LO level : 0 to +0.5V

8. BCD OUTPUT AND D/A OUTPUT (R8340A ONLY)

This function is given to the R8340A.

## 8.1 Selection of BCD OUTPUT

The R8340A realizes three types of outputs -- OFF (all high), BCD, and binary -- from the BCD OUTPUT connector on the rear panel. Select a type of output by setting parameter. For how to set parameters, see Item 4.5.2 "BCD OUTPUT". Because the signal for BCD and binary outputs is completely isolated from the analog system, the analog system is not affected by connecting external units.

### 8.1.1 BCD Output

Measured data is output as parallel signals in the form of the BCD (1-2-4-8) code. The BCD output is used for printout of measured data by a printer and interface for other units. Data stored in the internal memory is not output.

#### (1) Data Output Connector

Connector used (Equivalent of DAIICHI DENSHIKOGYO Product)  
 R8340A body side : 57-40500  
 Connection cable side : 57-30500

Figure 8-1 shows the relationship between output data name and pin number.

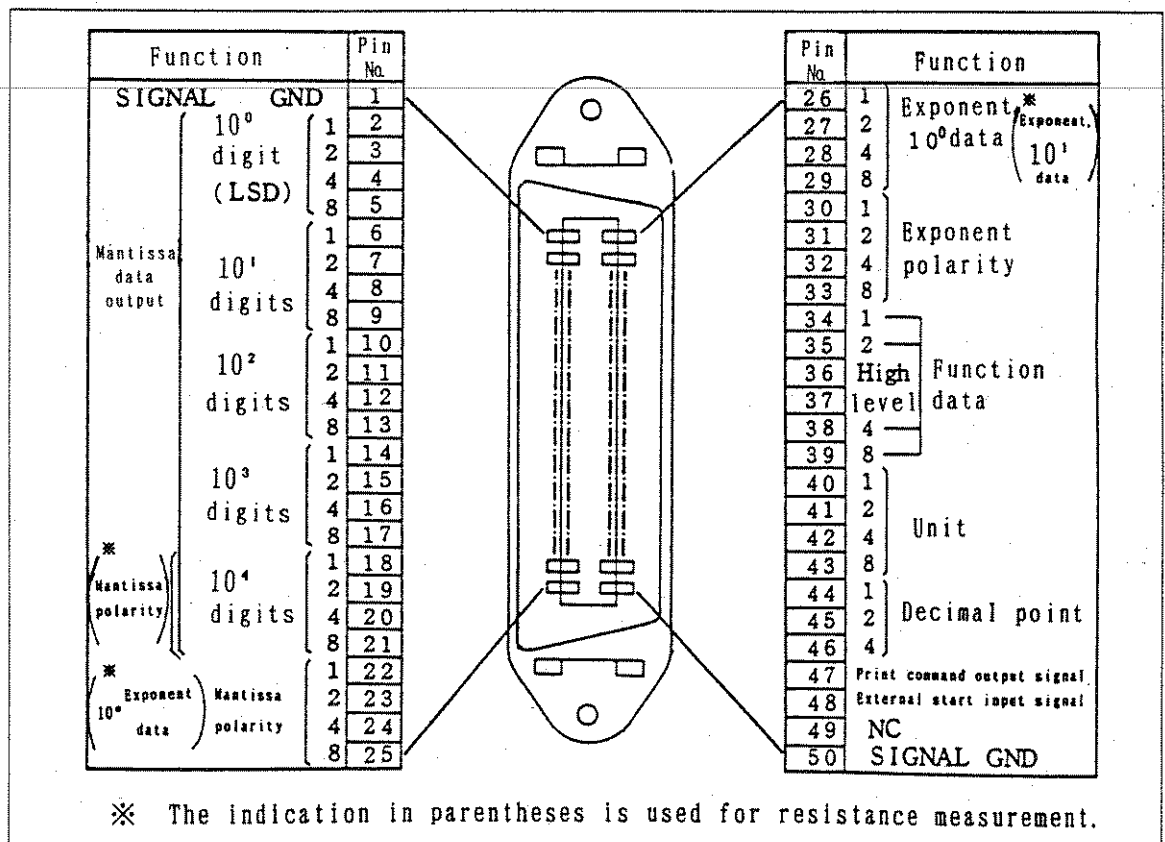
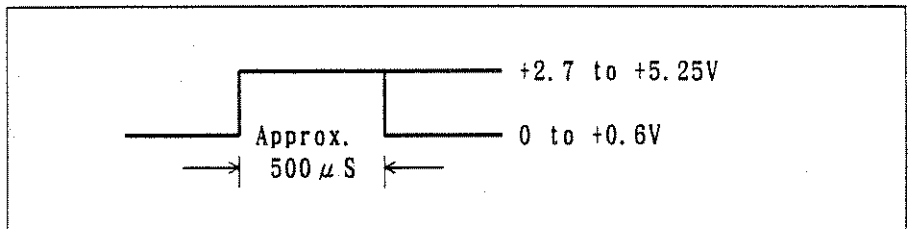

Figure 8 - 1 Description of BCD Data Output Connector Pins

(2) Signal Level

The output signal level uses the TTL (equivalent of SN74LS series) level as follows:

- ① Data Output : BCD (1-2-4-8) code  
 Positive logic  
 HI level : +2.7V to +5.25V  
           400  $\mu$ A max.  
 LO level : 0 to 0.6V  
           -5mA max.
- ② Print command signal : Positive pulse  
 HI level : +2.7V to +5.25V  
           400  $\mu$ A max.  
 LO level : 0 to 0.6V  
           -5mA max.  
 Pulse width : Approx. 500  $\mu$ S



③ Output Circuit

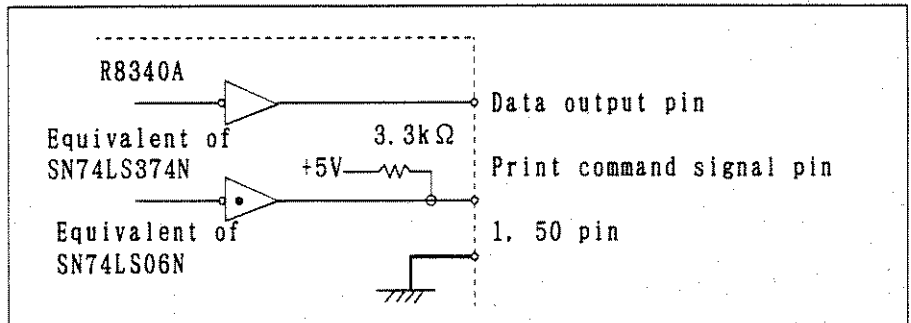



(3) Output Data Contents

① Measured Data

Value : Five digits (The following shows the relationship between digit and decimal point.)

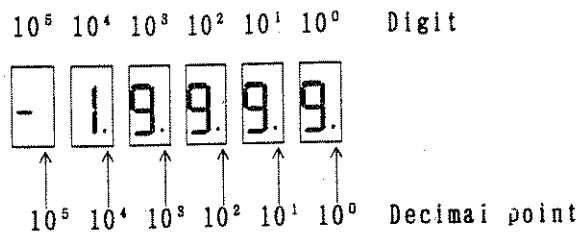

- Polarity : To be output in four bits as  $10^5$  digit data
- Decimal point : To be output in three bits
- Unit : To be output in four bits
- Others : To be output in four bits as function data for discrimination of type of data

Table 8-1 shows data output codes.

② Print Command Signal

The print command signal with the pulse width of approx. 500  $\mu$ s is output to the pin 47 synchronously with the end of measurement for one sample. Data contents are guaranteed by the output timing of the signal.

(4) External Start Input Signal

When SAMPLING on the front panel of the meter is set to HOLD, it is possible to externally input the measurement start signal. The external start signal inputs positive pulse between the pin 48 and the SIGNAL (1, pin 50). When inputting the start signal repeatedly, input it after the print command signal is output.

- HI level : +3.2 to +5.25V
- LO level : 0 to +0.5V
- Pulse width : 100  $\mu$ s or more (Operated at the rise of pulse)
- Chattering : 5ms or less

Table 8 - 1 Data Output Codes

Output name	Output data	Code			
		8	4	2	1
Data	0	0	0	0	0
	1	0	0	0	1
	2	0	0	1	0
	3	0	0	1	1
	4	0	1	0	0
	5	0	1	0	1
	6	0	1	1	0
	7	0	1	1	1
	8	1	0	0	0
	9	1	0	0	1
Polarity	Blank (Space)	1	1	0	1
	Blank (Space)	1	1	1	1
	Negative (-)	1	0	1	0
Polarity	Positive (+)	1	0	1	1
	Blank (Space)	1	1	1	1
	Blank (Space)	1	1	1	1
Decimal point	10 <sup>0</sup>		0	0	0
	10 <sup>1</sup>		0	0	1
	10 <sup>2</sup>		0	1	0
	10 <sup>3</sup>		0	1	1
	10 <sup>4</sup>		1	0	0
	10 <sup>5</sup>		1	0	1
Function data	OVER (*)	0	0	0	0
	GO (Space)	0	1	1	0
	LO (>)	1	0	0	0
	HI (<)	1	0	0	1
	Data when limiter is applied (#)	0	1	1	1
	NULL (L)	1	1	1	0
	Others (Space)	1	1	1	1

1 : HI level  
 0 : LO level

Table 8 - 1 Data Output Codes (Cont'd)

Output name	Output data	Code			
		8	4	2	1
Unit	$\Omega$ ( $\Omega$ )	0	1	0	0
	A (Space)	1	1	1	1

1 : HI level  
0 : LO level

Note: Data in parentheses shown by the polarity, function data, and unit is the print character when connecting the TR6198 digital printer.

When function data is simultaneously produced, the priority for indication is given as shown below.

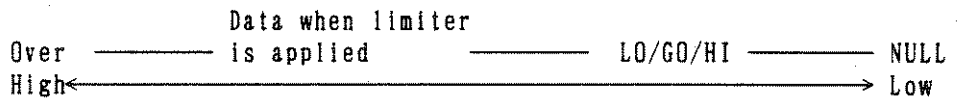

(5) Data output example of each IM/RM (For TR6198 digital printer)

Table 8 - 2 Data Output Example

IM/RM	Indication	BCD data output
		<div style="text-align: right;">                     ----- Exponent polarity                      ----- Exponent data                      ----- Mantissa polarity                      (Mantissa data                      Decimal point                      ----- Unit                 </div>
IM	$\pm 199.99\text{pA}$ $\pm 1.9999\text{nA}$ $\pm 99.99\ \mu\text{A}$	$- 9 \pm .19999$ $- 9 \pm 1.9999$ $- 6 \pm 099.99$
RM	$1.999 + 3\Omega$ $1.999 + 12\Omega$ $9. + 1\Omega$ $9.9 + 13\Omega$	$+ 03 \quad 1.999\Omega$ $+ 12 \quad 1.999\Omega$ $+ 01 \quad 0009. \Omega$ $+ 13 \quad 009.9\Omega$

## 8.1.2 Binary Output

Measured data is converted into binary parallel data and output. The data stored in the internal memory is not output.

### (1) Data Output Connector

The connector used is common to that for BCD output. See Item (1) of 8.1.1.

Figure 8-2 shows the relationship between output data name and pin No.

### (2) Signal Level

The output signal level is the same with that of BCD output. See Item (2) of 8.1.1.

### (3) Output Data Contents

#### ① Mantissa Part Data

The mantissa part data is output between 0 and 32768 in the form of 15-bit binary absolute value. The signal level uses positive logic.

#### ② Mantissa Part Sign

The sign shows the polarity of mantissa part data. The signal level uses positive logic, which is "+" for 0 and "-" for 1.

#### ③ Exponent Part Data

The exponent part data is output between 0 and 128 in the form of 7-bit binary absolute value. The signal level uses positive logic.

#### ④ Exponent Part Sign

The sign shows the polarity of exponent part data. The signal level uses positive logic, which is "+" for 0 and "-" for 1.

⑤ Function Data

The data shows the measurement state. The following is the description of each pin.  
 The signal level uses positive logic.

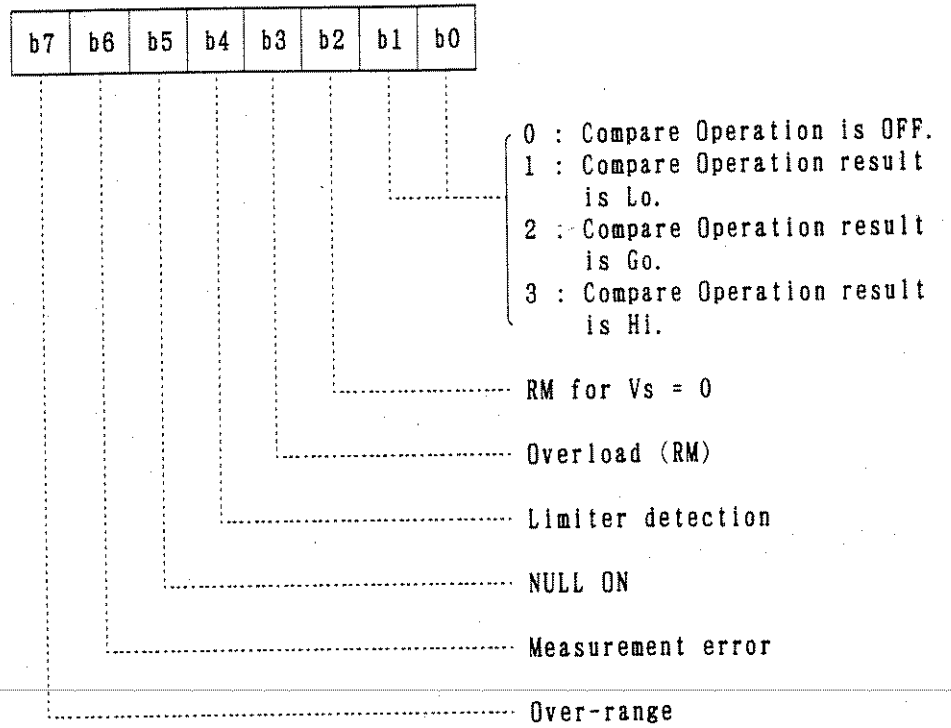

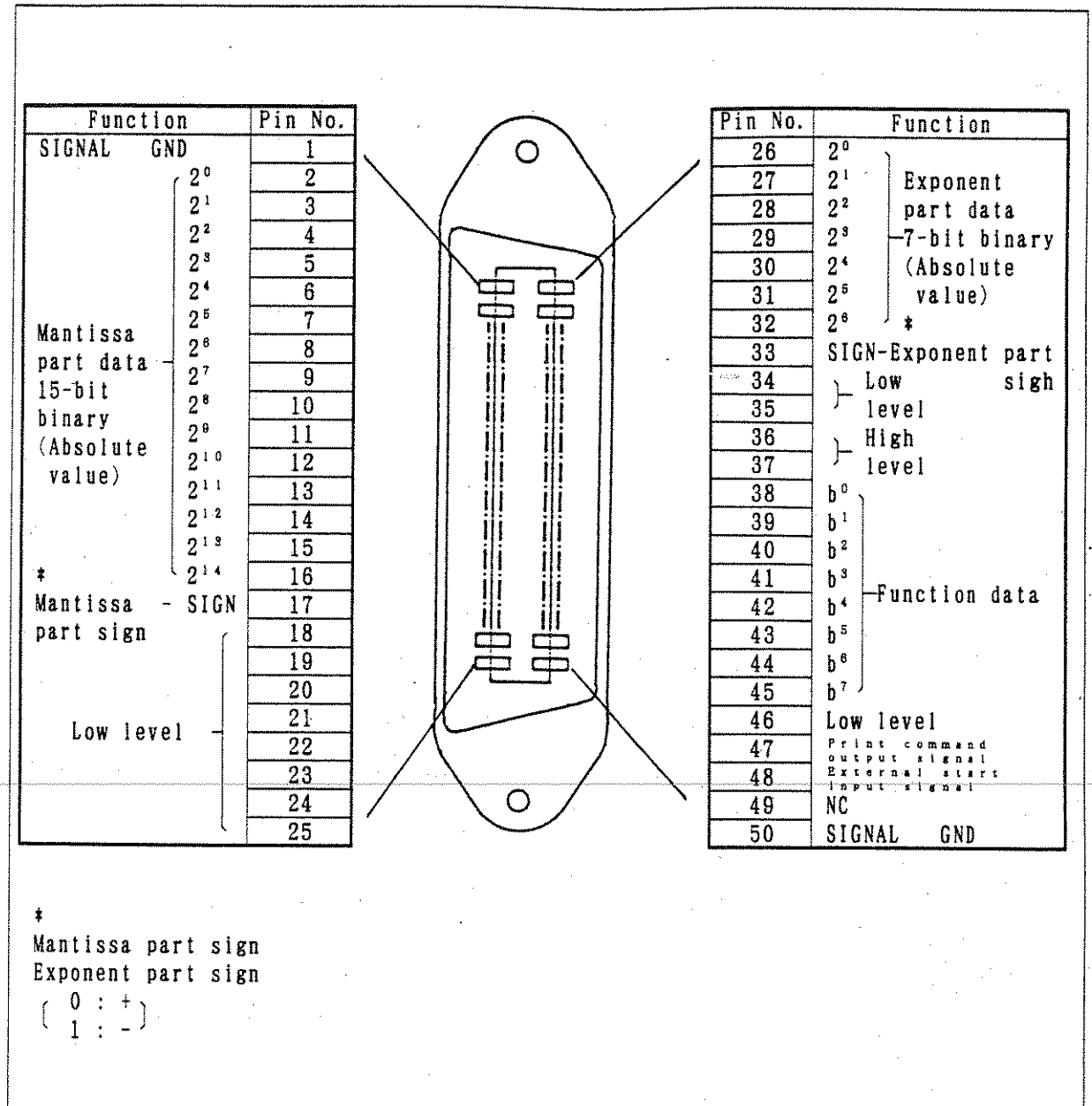

Figure 8 - 2 Description of Binary-output Connector Pins

## 8.2 D/A Output

Measured data is converted into analog signal by the D/A converter and output to the DA OUTPUT terminal on the rear panel. The conversion output can be set to any number of digits within three consecutive digits among data displayed by the full scale of 1V. The +50% offset voltage can also be set.

### (1) Specification

Output voltage : -1 to +1V  
 Conversion accuracy :  $\pm 0.2\% \pm 2d$   
 Output resistance :  $1\Omega$  or less  
 Maximum load current :  $\pm 0.5mA$   
 Output terminal : Binding post

### (2) Setting the number of digits for output data

See Item 4.5.1 "DA OUTPUT".

Figure 8-3 shows the relationship between indicated data and output voltage.

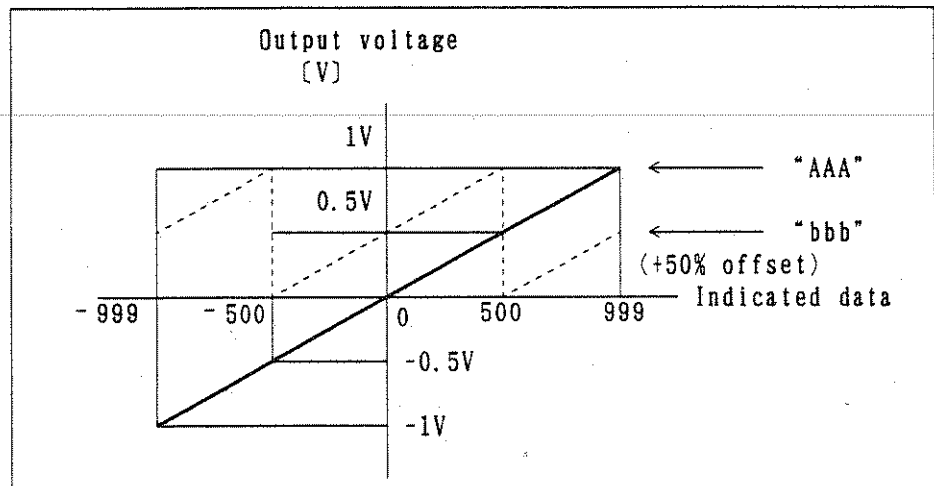

Figure 8 - 3 Output Voltage of DA OUTPUT

#### CAUTION:

When +50% offset voltage is set ("bbb"), output with no polarity is generated as shown by a dotted line in Figure 8-3.

## 9. TROUBLESHOOTING AND CALIBRATION

This section describes the troubleshooting method when a trouble occurs in the meter and the calibration method to maintain the measurement accuracy.



## 9.1 Before Requesting Repair

If a trouble occurs during operation of the meter, troubleshoot the meter according to Table 9-1. If the trouble is not settled even after troubleshooting, contact a nearby sales office, or your dealer.

Even for the repair of the following troubles, we will ask you for the repair charge if they are repaired by us. Therefore, make troubleshooting according to the table below before you request repair to us.

Table 9 - 1 Troubleshooting Items

Symptom	Probable cause	Remedy
No indication appears.	1. The power fuse blows.	1. Replace the fuse with the attached one. (See Item 1.3.5.)
Measured value is unstable or abnormal.	2. The IM/RM or range is incorrectly set. 3. The power frequency is erroneously set to 50 or 60Hz.	2. Recheck the IM/RM or range setting. 3. Adjust the frequency to the AC power frequency used. (See Item 4.5.4.)
Though the input signal is applied, no measurement is executed.	4. The cable is connected to an incorrect terminal. 5. The input protection fuse blows. 6. The measurement state is not set. 7. The cable is disconnected.	4. Connect the input cable to the correct input terminal. 5. Replace the fuse with the attached one. (See Item 1.3.5.) 6. Press the MEASURE key to set the measurement state. 7. Check the cable with a multimeter and replace it if it is faulty.
No voltage is generated.	8. The voltage is set to 0V. 9. The discharge state is set. 10. The state is stand-by because over-voltage input is detected.	8. Check the generated-voltage set value. 9. Press the CHARGE/MEASURE key to set the charge/measurement state. 10. Remove the connection cable.

## 9.2 Calibration

This section describes the calibration method with one cycle of measurement accuracy assurance period (six months) to maintain the measurement accuracy shown in Section 12. "Performance data".

### 9.2.1 Preparation and Precaution for Calibration

The following describes the equipment and precautions for calibration.

#### (1) Equipment Necessary for Calibration

Use the equipment in Table 9-2 or those with the performance equal to or better than that of the equipment in Table 9-2 as the standard equipment.

Table 9 - 2 Equipment Necessary for Calibration

Calibration equipment	Range	Accuracy	Recommended equipment
Standard DC voltage generator	$\pm 0\text{mV}$ to $\pm 20$	Within $\pm 0.005\%$	TR6120 (Made by ADVANTEST CORPORATION)
Standard direct-current generator	$\pm 0\ \mu\text{A}$ to $\pm 2\text{mA}$	Within $\pm 0.01\%$	TR6120 (Made by ADVANTEST CORPORATION)
Standard resistor	$0\ \Omega$ to $20\text{M}\Omega$	Within $\pm 0.01\%$	
	$100\text{M}\Omega$	Within $\pm 0.03\%$	
	$1\text{G}\Omega$ $10\text{G}\Omega$	Within $\pm 0.14\%$ Within $\pm 0.14\%$	
Digital voltmeter	0 to 1000V	Within $\pm 0.005\%$	TR6878, TR6871, R6871E (Made by ADVANTEST CORPORATION)

(2) Cables Necessary for Calibration

Table 9-3 shows the cables necessary for calibration.

Table 9 - 3 Cables Necessary for Calibration

Product name	Standard
Input/output cable	A01010
Input cable	BI-109
TRIAx-BNC cable +BNCJ-MP adapter	A01011+A04207

(3) General Cautions for Calibration

- ① Use the specified voltage for the AC power supply.
- ② Use parameters according to the power frequency to set the frequency to 50 or 60Hz.
- ③ To connect the power cable, Check if the power switch is turned off.
- ④ Perform calibration under the ambient conditions shown below.  
 Temperature :  $+23^{\circ}\text{C} \pm 3^{\circ}\text{C}$   
 Relative humidity: 70% or less  
 Perform calibration at the place free from dust, vibration, and noise.
- ⑤ Preheat each calibration equipment for the specified time.  
 Preheat the meter for 1 hr or more. (For calibration)
- ⑥ After calibration, it is recommended to indicate the calibration date and the next calibration time limit using a card or sticker.

### 9.2.2 Calibration Data Initialization

When initializing calibration data, the whole calibration data is deleted and the typical value of calibration data is set. If "ERR2" (Breakdown of calibration primary data) occurs, initialize the calibration data. Then continue calibration according to the procedure in Item 9.2.3. The following describes how to initialize calibration data.

#### Operation

- ① Turn off the power switch.
- ② Set the EXIT CAL switch on the rear panel to ON.
- ③ Immediately after turning on the power switch, press the  key.

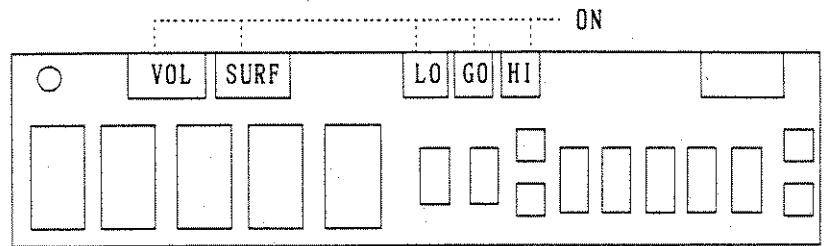

Calibration correction mode

- ④ When the  key is pressed, the initial value is set to calibration data.

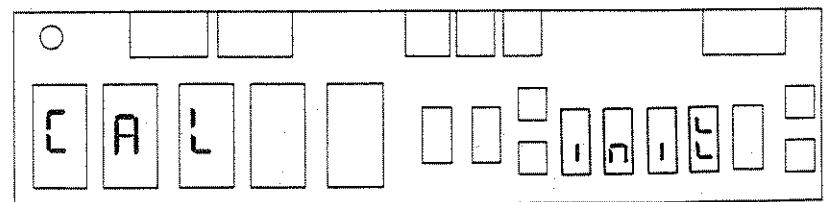

During setting the initial value

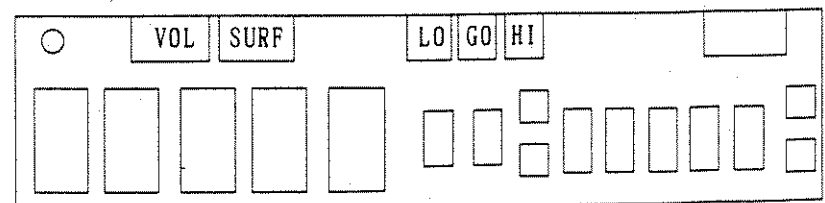

End of initial value setting.  
 Calibration correction mode

### 9.2.3 Calibration Method

For normal calibration, the calibration in the following Item (1) is skipped and the calibration checking and adjustment in the following Item (2) is executed.

However, any condition comes under the following three items, perform the operation in both Items (1) and (2).

- When an indication of the meter is deviated 10 counts or more from that of the standard meter.
- When calibration data is initialized.
- When "ERR2" occurs.

The following shows key functions in the calibration mode.

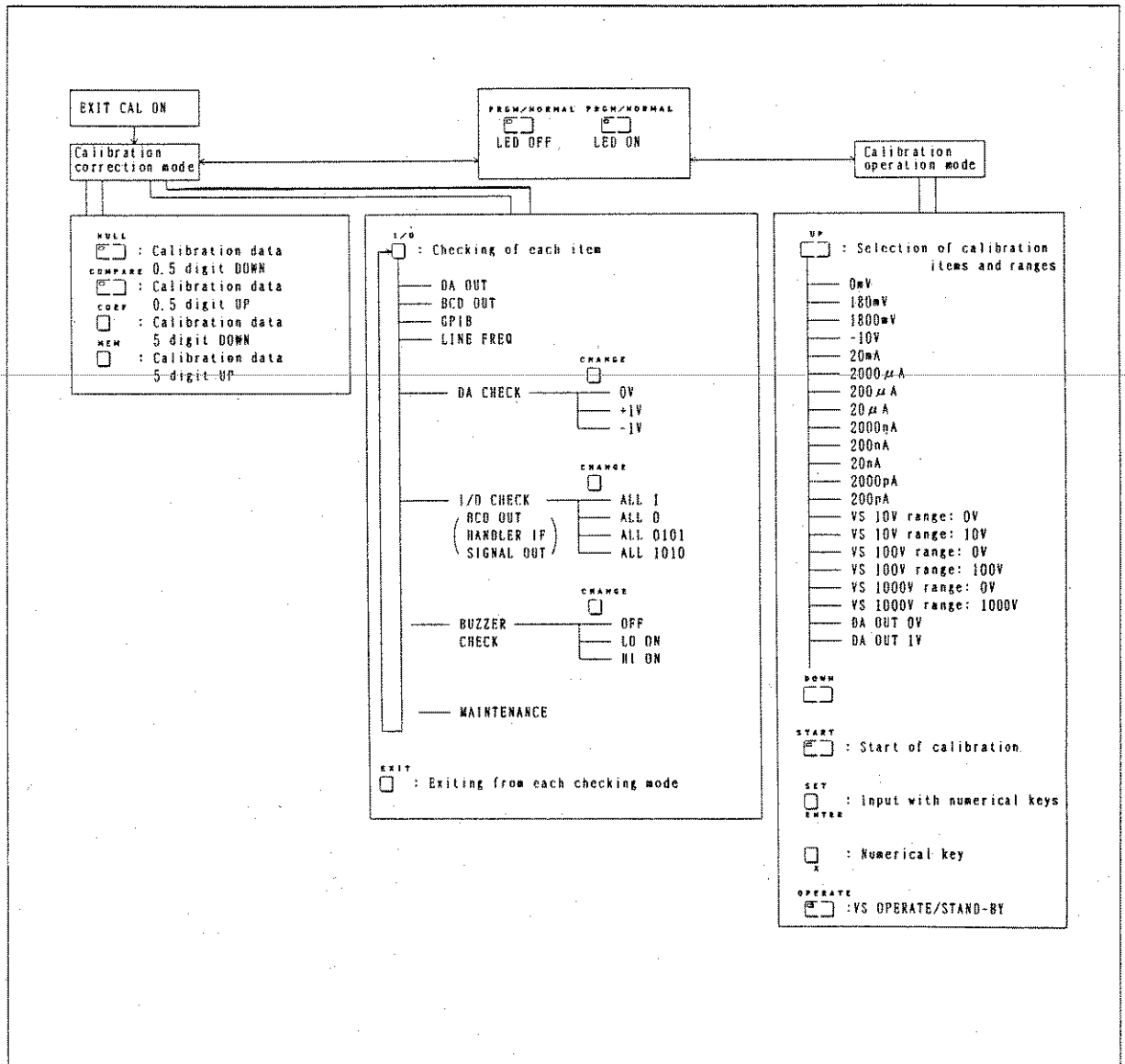

Figure 9 - 1 Key Functions in Calibration Mode

(1) Calibration (Calibration operation mode)

Perform calibration for each item and each range.

Select calibration items with the <sup>UP</sup>  and <sup>DOWN</sup>  keys.

One item advances by pressing the <sup>UP</sup>  key and goes back by

pressing the <sup>DOWN</sup>  key. The calibration items ranges between ① and ⑩. Items ① through ② are the calibration for current measurement, items ② through ④ are the calibration for voltage generation, and items ③ through ⑩ are the calibration for DA OUTPUT (R8340A only).

For items ① through ⑧, the calibration is made by applying the internal standard voltage to the AD converter.

(1-1) Calibration for Current Measurement

Operation (① through ⑩)

- ① Turn on the power switch.
- ② Set the EXIT CAL switch on the rear panel to ON.

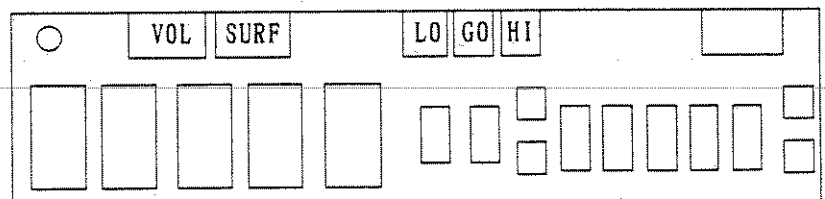

Calibration correction mode

- ③ Connect the input/output cable (A01010) to the meter and connect the short bar as shown in Figure 9-2.

- ④ Press the <sup>PRGM/NORMAL</sup>  key, and the LED on the key lights.

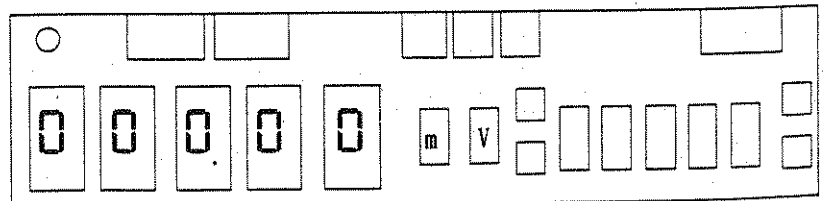

Calibration correction mode

- ④-1 Connect the red and blue input cables to short-circuit the input and perform the following procedures.  
(Disconnect the black cable.)
- ④-2 Press the <sup>START</sup>  key, and the LED on the key lights and the calibration starts.  
When the LED on the key goes out, the calibration for 0mV ends.

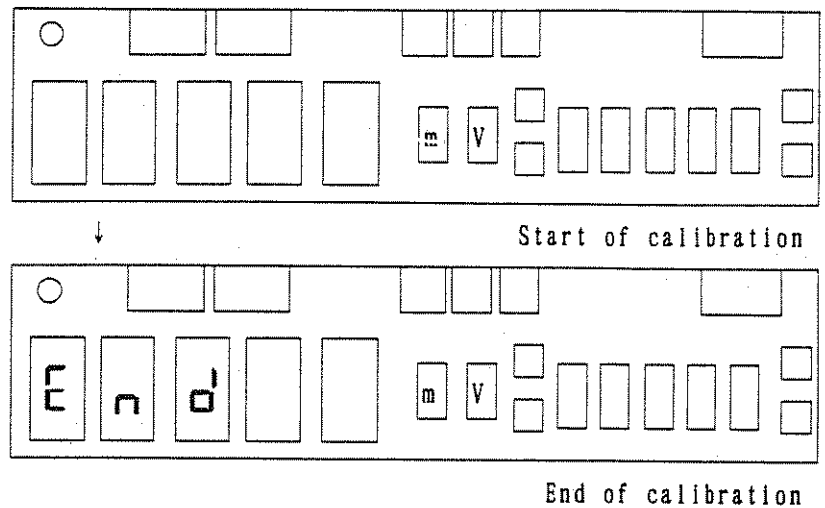

- ⑤ Connect the standard DC voltage/current generators with the meter as shown in Figure 9-2 (C). (Disconnect the black cable.)
- ⑥ Press the <sup>UP</sup>  key.
- ⑥-1 Set the standard DC voltage generator to +180.00mV.

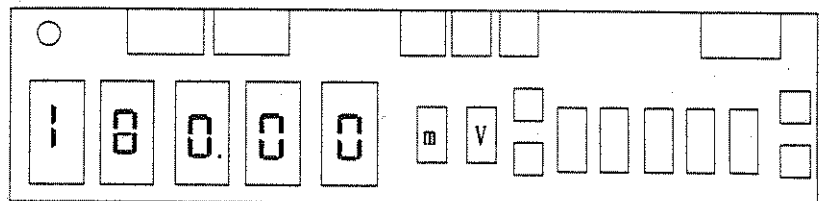

Unless the standard DC voltage generator can be set to the indication value of the meter, adjust the value to the output value of the standard DC voltage generator through key-in operation.

When the standard DC voltage generator outputs 170.00mV, for example, set the value by pressing the keys

SET

Subsequently, unless the standard equipment output value can be set to the indication value, set the value according to the above procedure. For the setting range, see Table 9-5 to use the standard equipment within the range.

⑥-2 Press the <sup>START</sup>  key to execute the calibration for 180.00mV according to the procedure in Item ④.

⑦ Press the <sup>UP</sup>  key.

When pressing the <sup>DOWN</sup>  key instead of the <sup>UP</sup>  key, the preceding item appears.

⑦-1 Set the standard DC voltage generator to +1800.0mV.

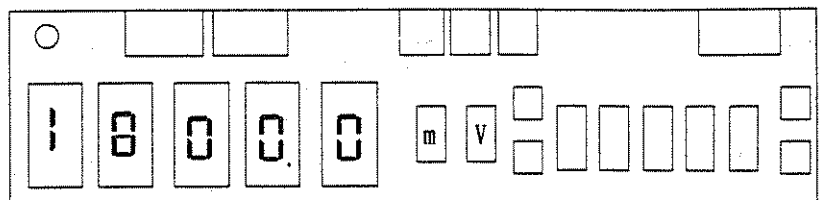

⑦-2 Press the <sup>START</sup>  key to execute the calibration for 1800.00mV according to the procedure in Item ④.

⑧ Connect the black clip and the blue clip to the same terminal.

⑨ Press the <sup>UP</sup>  key.

⑨-1 Set the standard DC voltage generator to -10.000V.

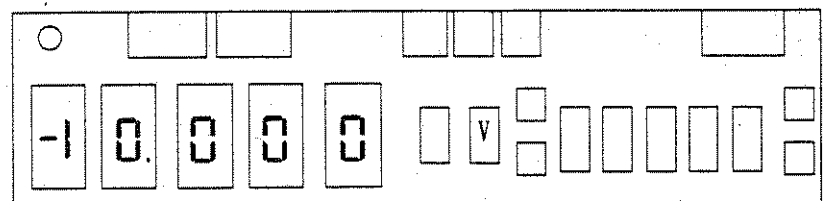

⑨-2 Press the <sup>START</sup>  key to execute the calibration for -10.000V according to the procedure in Item ④.

⑩ Disconnect the black clip.



⑪ Press the <sup>UP</sup>  key.

⑪-1 Set the standard direct-current generator to +20.000mA.

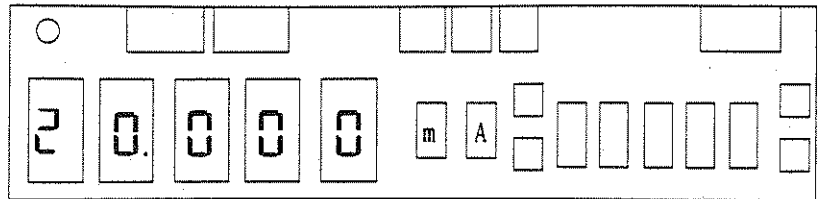

⑪-2 Press the <sup>START</sup>  key to execute the calibration for +20.000mA according to the procedure in Item ④.

⑫ Press the <sup>UP</sup>  key.

⑫-1 Set the standard direct-current generator to +2000.0 μA.

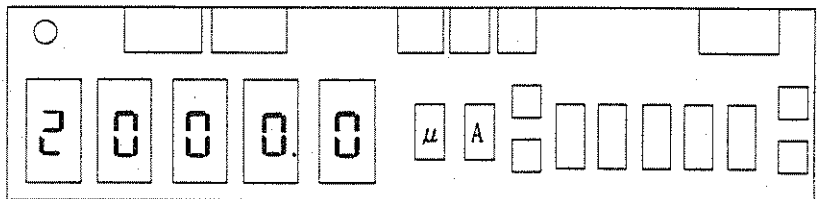

⑫-2 Press the <sup>START</sup>  key to execute the calibration for +2000.0 μA according to the procedure in Item ④.

⑬ Press the <sup>UP</sup>  key.

⑬-1 Set the standard direct-current generator to +200.00 μA.

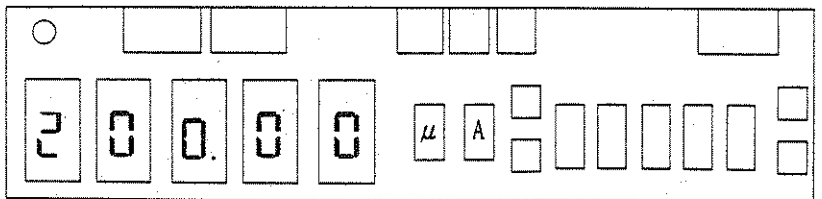

⑬-2 Press the <sup>START</sup>  key to execute the calibration for +200.00 μA according to the procedure in Item ④.

⑭ Connect the standard direct-current generator with the standard resistance as shown in Figure 9-2 (b).

15 Press the <sup>UP</sup>  key.

15-1 Set the standard direct-current generator so that the input current will be  $+20.000 \mu\text{A}$  according to Table 9-4.

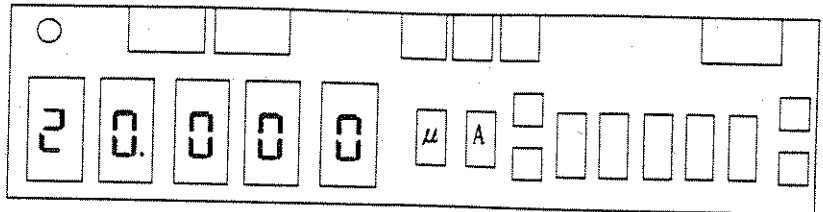

15-2 Press the <sup>START</sup>  key to execute the calibration for  $+20.000 \mu\text{A}$  according to the procedure in Item 4.

16 Press the <sup>UP</sup>  key.

16-1 Set the standard direct-current generator so that the input current will be  $+2000.0\text{nA}$  according to Table 9-4.

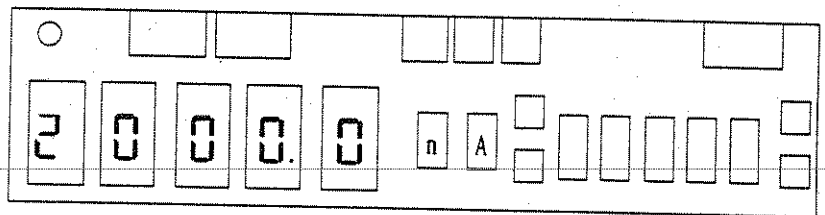

16-2 Press the <sup>START</sup>  key to execute the calibration for  $+2000.0 \text{nA}$  according to the procedure in Item 4.

17 Connect the standard direct-current generator with the standard resistance as shown in Figure 9-2 (a).

18 Press the <sup>UP</sup>  key.

18-1 Set the standard direct-current generator so that the input current will be  $+200.00\text{nA}$  according to Table 9-4.

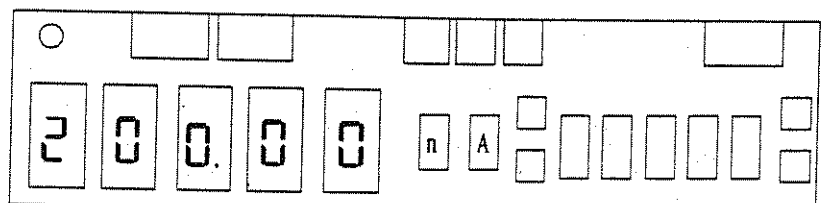



18-2 Press the <sup>START</sup>  key to execute the calibration for  $+200.00 \text{nA}$  according to the procedure in Item 4.

⑱ Press the  key.

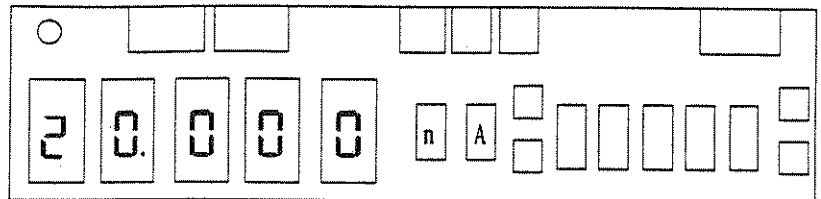
⑱-1 Set the standard direct-current generator so that the input current will be +20.000nA according to Table 9-4.





⑱-2 Press the  key to execute the calibration for +20.000 nA according to the procedure in Item ④.

⑳ Press the  key.

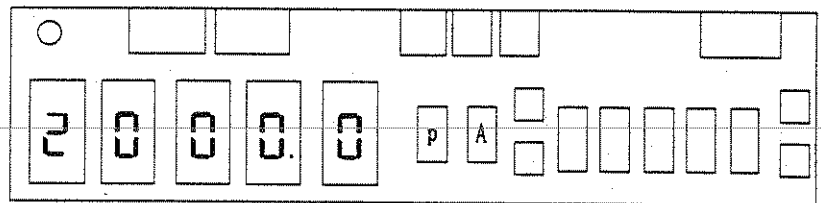
⑳-1 Set the standard direct-current generator so that the input current will be +2000.0pA according to Table 9-4.



⑳-2 Press the  key to execute the calibration for +2000.0 pA according to the procedure in Item ④.

㉑ Press the  key.

㉑-1 Set the standard direct-current generator so that the input current will be +200.00pA according to Table 9-4.

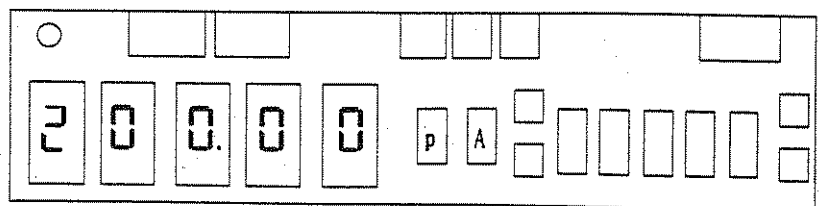

㉑-2 Press the  key to execute the calibration for +200.00 pA according to the procedure in Item ④.



- ⑳-3 Press the <sup>START</sup>  key, and the LED on the key lights and the calibration starts.  
When the LED on the key goes out, the calibration ends.

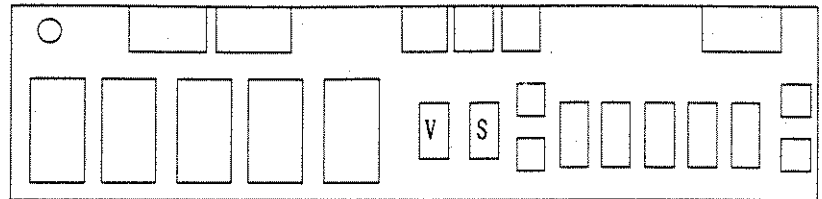

↓

Start of calibration

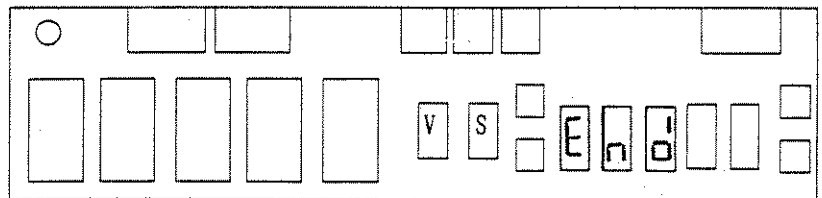

End of calibration

- ㉑ Press the <sup>UP</sup>  key.

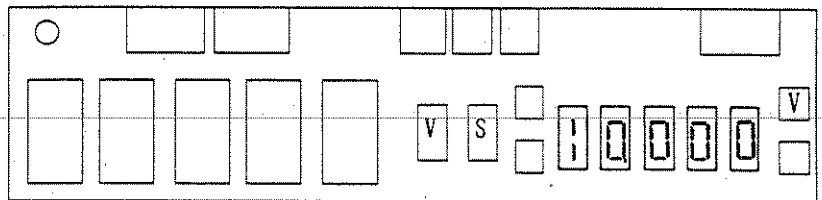

Similarly to Item ㉑, read the indication value on the digital voltmeter to input the value and execute the

the calibration by pressing the <sup>START</sup>  key.

**CAUTION**

Be sure to execute the calibration for voltage generation in order of 0V to full scale for each range.  
The calibration is internally executed with the data for two points of 0V and full scale.

- ㉒ Press the <sup>UP</sup>  key.

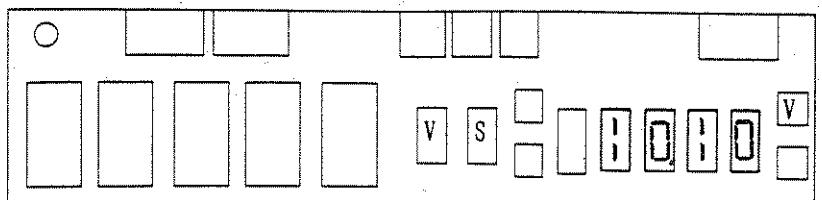

Similarly to Item 24, read the indication value on the digital voltmeter to input the value and execute the

calibration by pressing the  key.

27 Press the  key.

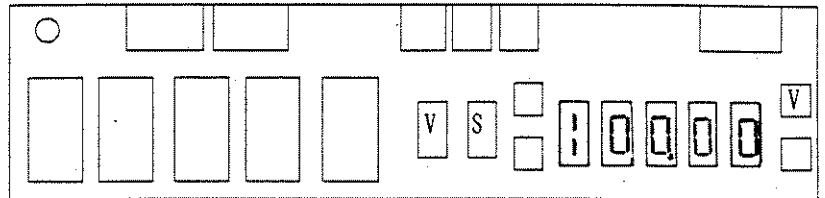

Similarly to Item 24, read the indication value on the digital voltmeter to input the value and execute the

calibration by pressing the  key.

28 Press the  key.

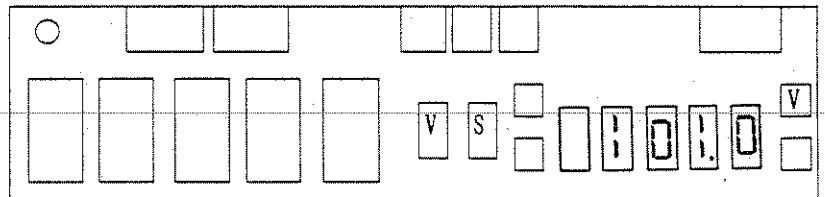

Similarly to Item 24, read the indication value on the digital voltmeter to input the value and execute the

calibration by pressing the  key.

29 Press the  key.

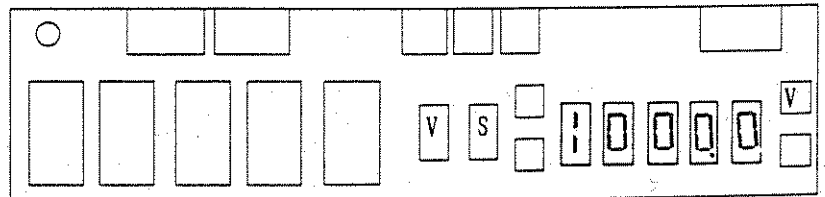

Similarly to Item 24, read the indication value on the digital voltmeter to input the value and execute the

calibration by pressing the  key.

(1-3) Calibration for DA OUTPUT (R8340A only)

Operation

② Press the <sup>UP</sup> key.

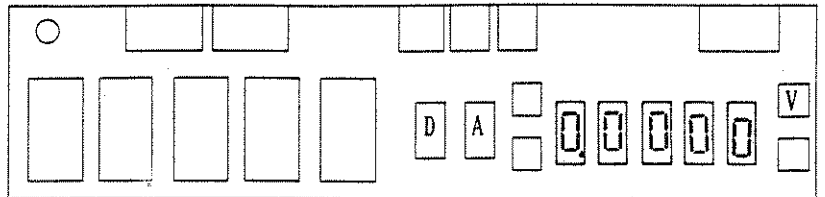

Similarly to Item ②, read the indication value on the digital voltmeter to input the value and execute the

calibration by pressing the <sup>START</sup> key.

③ Press the <sup>UP</sup> key.

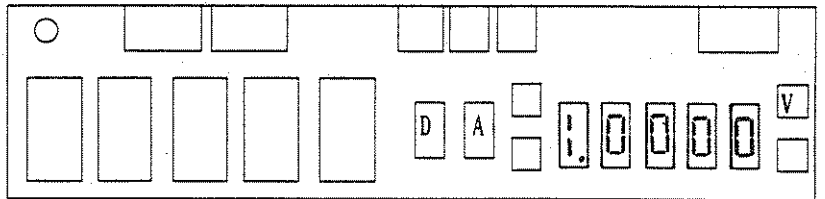

Similarly to Item ②, read the indication value on the digital voltmeter to input the value and execute the

calibration by pressing the <sup>START</sup> key.

This completes the whole calibration. Then start the operation in Item (2).

CAUTION

1. To execute the calibration for current measurement with the TR6120, use only the ranges 200  $\mu$ A, 2mA, and 20mA.
2. For the calibration for the range of 200  $\mu$ A or less, use the V function of TR6120 and the standard resistor.
3. For the calibration for the range of 200nA or less, it is recommended to use the input cables A01011 and A04207 for the TR6120 and TR45 to decrease the influence of induction noise.
4. The calibration for the range of 200nA or less (especially for the range of 2nA or less) requires the time between several seconds and several tens of seconds. Protect the cable and body from vibration.

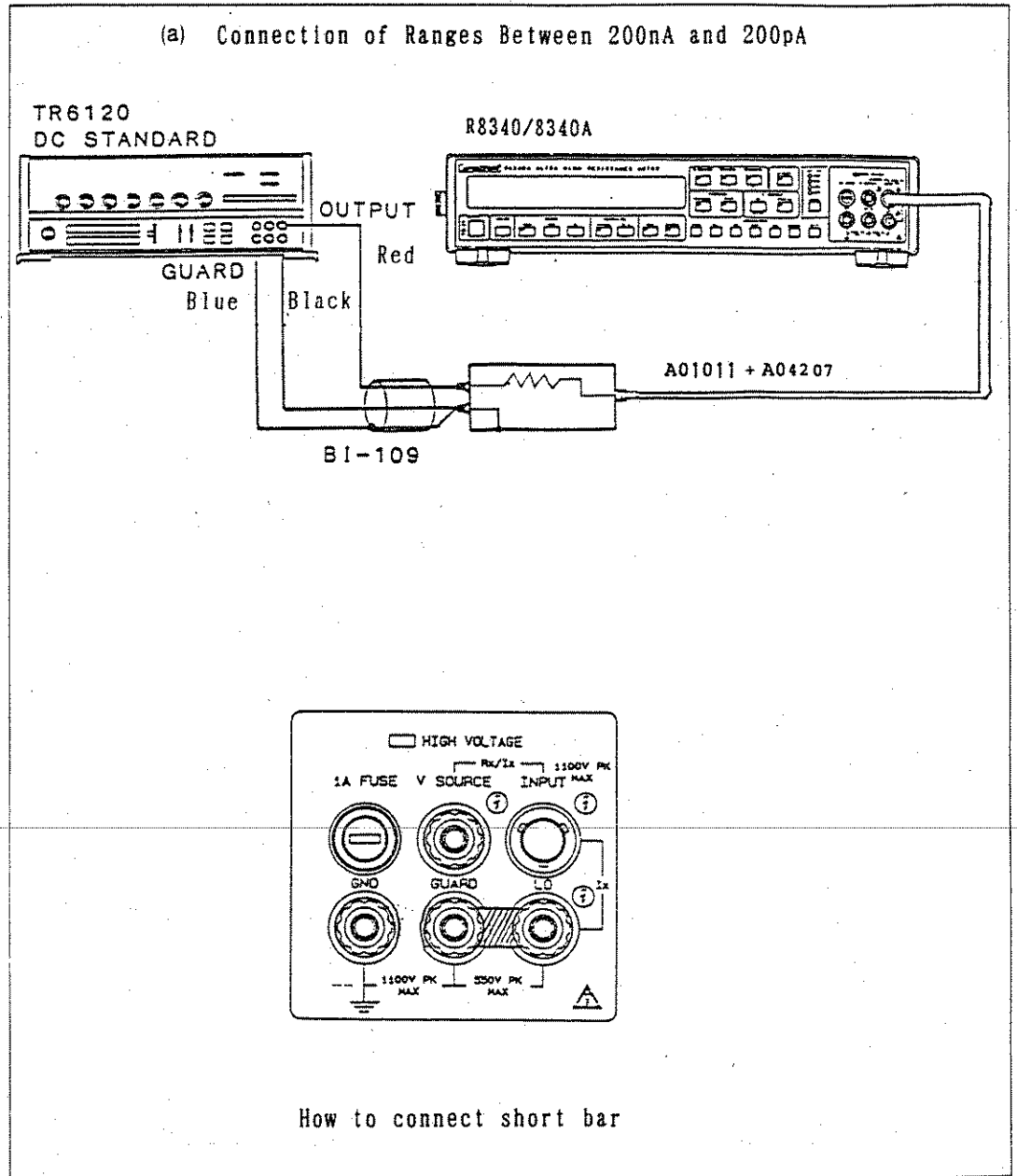

Figure 9 - 2 Connection for Current Measurement Calibration



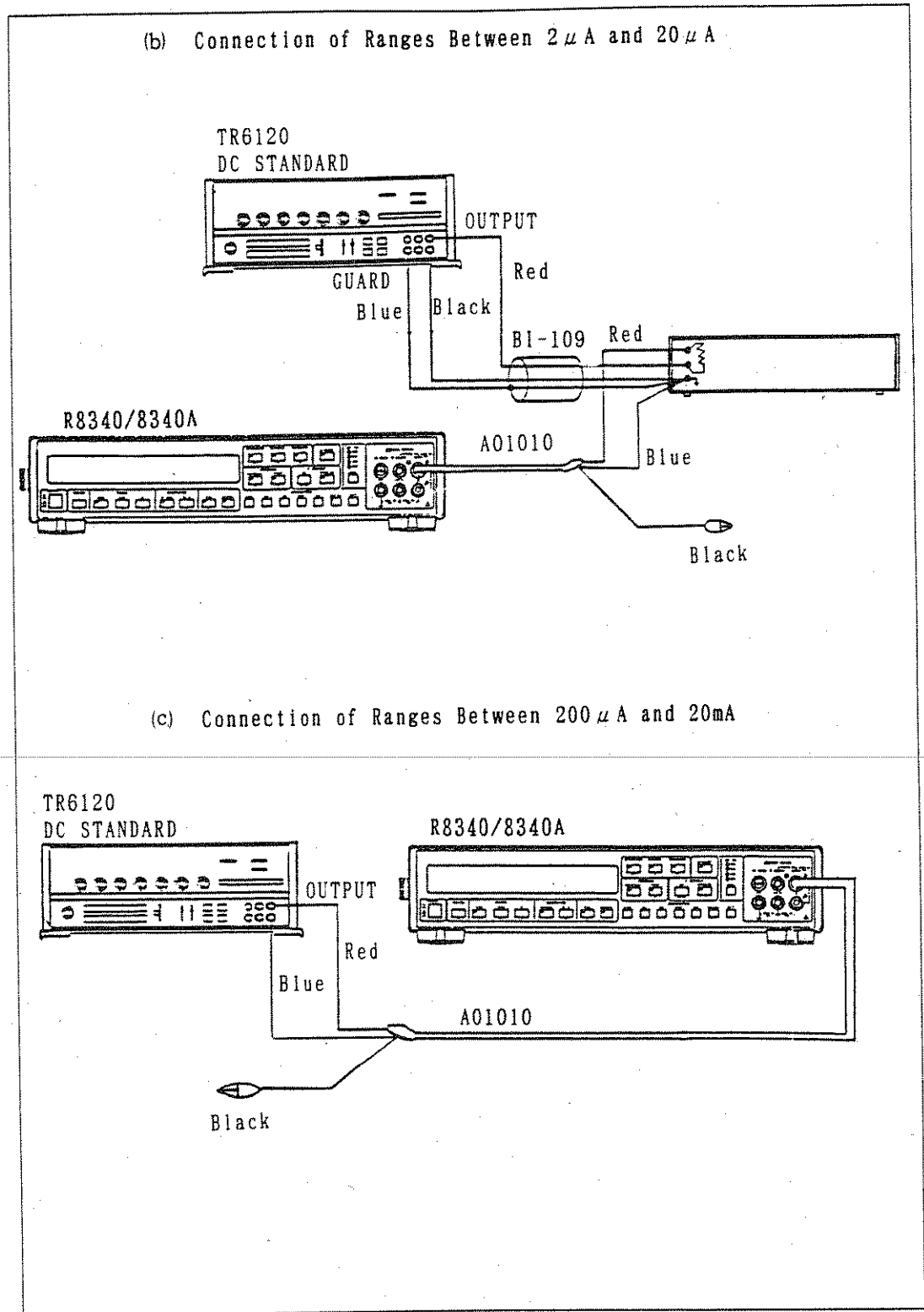

Figure 9 - 2 Connection for Current Measurement Calibration (Cont'd)

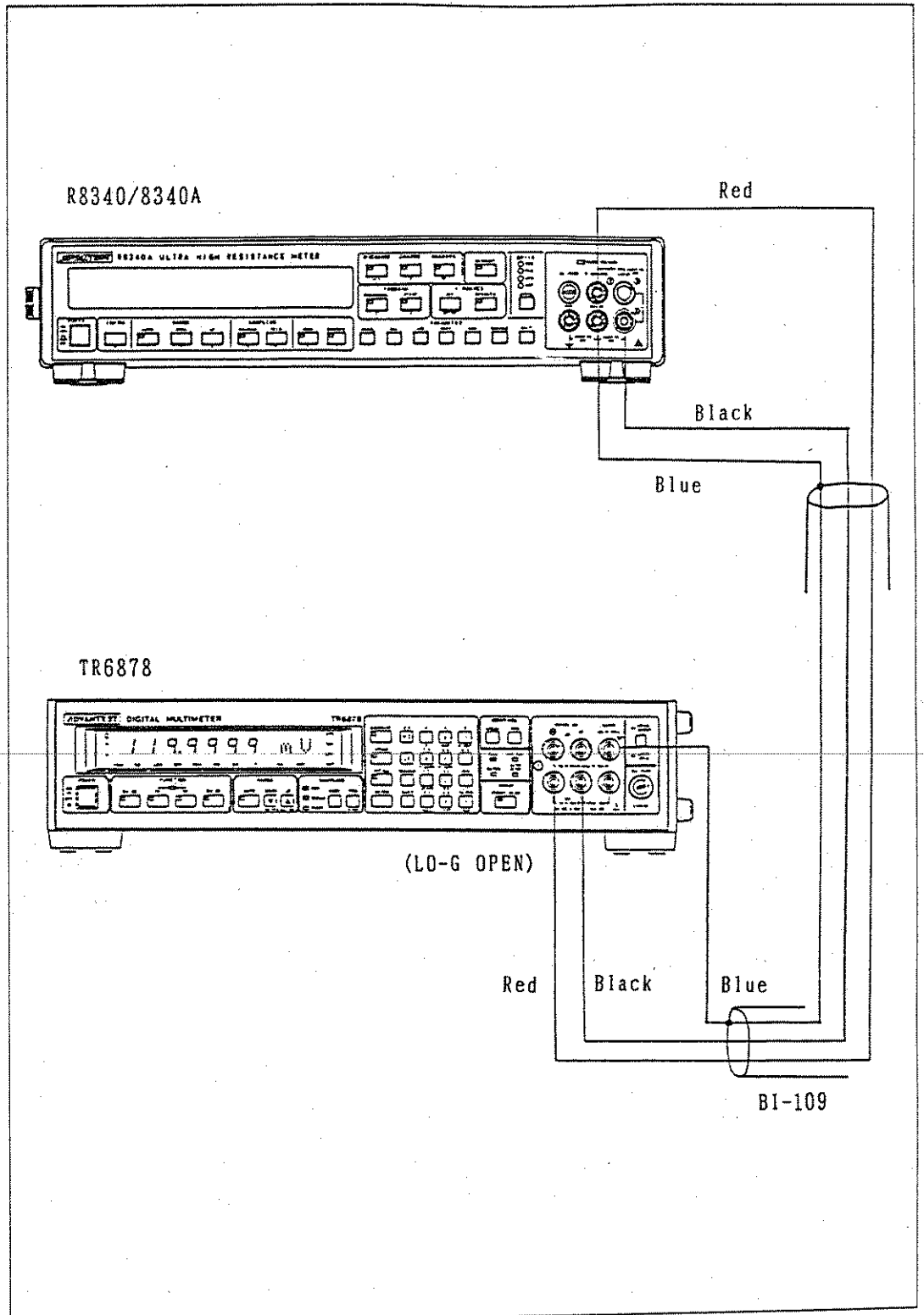

Figure 9 - 3 Connection for Voltage Generation Calibration

Table 9 - 4 Setting of Standard Direct-current Generator for Calibration

Indication	Standard equipment	Setting of TR6120 #1
200pA	TR6120+Standard resistor (10GΩ)	$2 \times R \times 10^{-10}V$
2000pA	TR6120+Standard resistor (10GΩ)	$20 \times R \times 10^{-10}V$
20nA	TR6120+Standard resistor (100MΩ)	$2 \times R \times 10^{-8}V$
200nA	TR6120+Standard resistor (100MΩ)	$20 \times R \times 10^{-8}V$
2000nA	TR6120+Standard resistor (1MΩ)	$2 \times R \times 10^{-8}V$
20 μA	TR6120+Standard resistor (1MΩ)	$20 \times R \times 10^{-8}V$
200 μA	TR6120	0.20000mA
2000 μA	TR6120	2.00000mA
20mA	TR6120	20.0000mA
-10V	TR6120	-10.0000V
1800mV	TR6120	1.80000V
180mV	TR6120	0.18000V

R:Calibration value of standard resistor

\*1: When the calibration value of the standard resistor is  $0.9988 \times 10^{10} \Omega$ , for example:  
Set the voltage of the TR6120 to the following value using the formula in Table 9-4.

$$V = 20 \times 0.9988 = 19.976V$$

In this case, check if the meter reads

"2000.0" pA before pressing the  <sup>START</sup> key.

Table 9 - 5 Each Calibration Item Setting Range

Item	Indication	Setting range	Item	Indication	Setting range
0mV	000.00mV	Only "000.00mV" cannot be set.	VS 10V 0V	VS 00.000V	-2.000V to +2.000V
180mV	180.00mv	+70.00mV to +220.00mV	VS 10V 10V	VS 10.000V	+7.000V to +11.999V
1.8V	1800.0mv	+700.0mV to +2200.0mV	VS 100V 0V	VS 010.10V	-20.00V to +20.00V
-10V	-10.000v	-7.000V to -10.000V	VS 100V 100V	VS 100.00V	+70.00V to +119.99V
20mA	20.000mA	+7.000mA to +22.000mA	VS 1000V 0V	VS 0101.0V	-200.0V to +200.0V
2mA	2000.0 $\mu$ A	+700.0 $\mu$ A to +2200.0 $\mu$ A	VS 1000V 1000V	VS 1000.0V	+700.0V to +1199.9V
200 $\mu$ A	200.00 $\mu$ A	+70.00 $\mu$ A to +220.00 $\mu$ A	DA OUT 0V	DA 0.0000V	-0.2000V to +0.2000V
20 $\mu$ A	10.000 $\mu$ A	+7.000 $\mu$ A to +22.000 $\mu$ A	DA OUT 1V	DA 1.0000V	+0.7000V to +1.1999V
2 $\mu$ A	1000.0nA	+700.0nA to +2200.0nA			
200nA	100.00nA	+70.00nA to +220.00nA			
20nA	10.000nA	+7.000nA to +22.000nA			
2nA	1000.0pA	+700.0pA to +2200.0pA			
200pA	100.00pA	+70.00pA to +220.00pA			

CAUTION

1. If a value exceeding the above range is set, an input error occurs when the  key is pressed.
2. If you input an incorrect value, press the  key. Then the preceding data appears and you can set new data.

(2) Calibration checking and adjustment (Calibration correction mode)

After completing the calibration in Item (1), start the following operation.

Operation

- ① Press the <sup>PRGM/NORMAL</sup>  key, and the LED on the key lights.

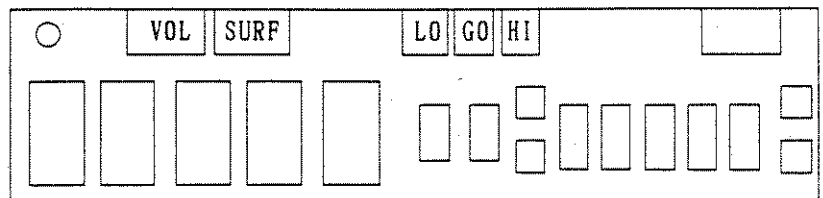

Calibration correction mode

When performing only the calibration checking and adjustment without executing the calibration in Item (1), start the following operation because the calibration correction mode is set when setting the EXIT CAL switch to ON.

The calibration correction mode and the calibration operation mode are changed over whenever the <sup>PRGM/NORMAL</sup>  key is pressed.

- ② Table 9-6 shows the adjustment error range of each range. Check the current range after executing zero cancel for each range (see Item 4.3.1). Though calibration is possible for full scale of up to 22000 in the calibration operation mode, the maximum measurement indication is "19999" in the calibration correction mode similarly to normal measurement. Therefore, for the checking in Table 9-6, set the full scale to approx. 18000.

For 180.00pA, for example:

$$\begin{aligned} \text{Set the voltage to } V &= 180.00\text{pA} \times 0.9988 \times 10^{10} \Omega \\ &= 1.79784\text{V} \end{aligned}$$

by assuming the calibration value of the standard resistor as  $0.9988 \times 10^{10} \Omega$ .

Table 9 - 6 Calibration Checking Error Range

Range	Error range	
	Zero point	+ Full scale
20mA	± 1d	± 3d
2mA	± 1d	± 3d
200 μ A	± 1d	± 3d
20 μ A	± 1d	± 3d
2 μ A	± 1d	± 3d
200nA	± 1d	± 3d
20nA	± 1d	± 3d
2nA	± 1d	± 5d
200pA	± 2d	± 10d
10V	± 2.5mV	± 2.5mV
100V	± 25mV	± 25mV
1000V	± 250mV	± 250mV

③ If measured values are out of the error range in Table 9-6, make adjustment using the keys shown below.

NULL

: Rewrites the calibration data in the presently-indicated measurement range so that it will be decreased by approx. 0.5 digits.

COMPARE

: Rewrites the calibration data in the presently-indicated measurement range so that it will be increased by approx. 0.5 digits.

COEF

: Rewrites the calibration data in the presently-indicated measurement range so that it will be decreased by approx. 5 digits.

MEM

: Rewrites the calibration data in the presently-indicated measurement range so that it will be increased by approx. 5 digits.

When make adjustment zero point of 200pA range, after pressing the above-mentioned key, executing zero cancel (See item 4.3.1).

CAUTION

1. It is impossible to adjust the zero point for current measurement and the voltage generation for ranges other than the 200pA range.
2. For the 200pA range, it takes several minutes until measured value is stabilized after the set voltage of the standard equipment is changed over. Start the calibration checking and adjustment after the value is completely stabilized.

(3) Storing of Calibration Data

After completion of calibration, store the calibration data through the following operation. However, it is not needed to store the data when only the operation in Item (2) "calibration checking and adjustment" is executed and measured values are kept within the error range but not corrected.

Operation

- ① Press the  key.

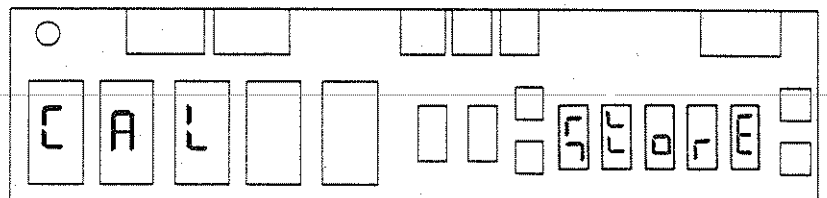

↓ During storage of calibration data

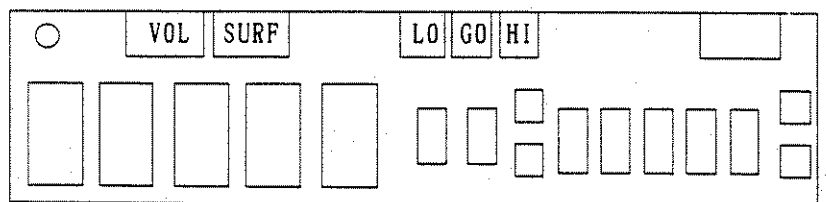

End of calibration data storage,  
Calibration correction mode.

(4) Cancel of Calibration Mode

Operation

- ① Turn off the EXIT CAL switch, and all calibration modes are canceled and the state is changed to the normal measurement mode.

(5) Key Functions in Calibration Mode

In the calibration mode, key functions differs from those in the normal mode. However, keys other than those in Figure 9-1 show normal functions.



10. DESCRIPTION OF OPERATION.

This section describes the outline of operation theory of the meter.

## 10.1 Outline of Operation

Figure 10-1 shows the block diagram of the meter. The meter uses two CPUs (microprocessors) one for control of the AD converter, V-SOURCE, and I-V converter, and the other for interface with external units and indication of data. Data is transferred between CAPs by an optoisolator.

R8340A is different from R8340 in the fact that the R8340A uses 1100V parts with a high dielectric strength capable of floating for the input connector, input/output cable, and photoisolator and has the BCD and DA output terminals to output data to external units.

This section describes the guard section which functions as a measurement part.

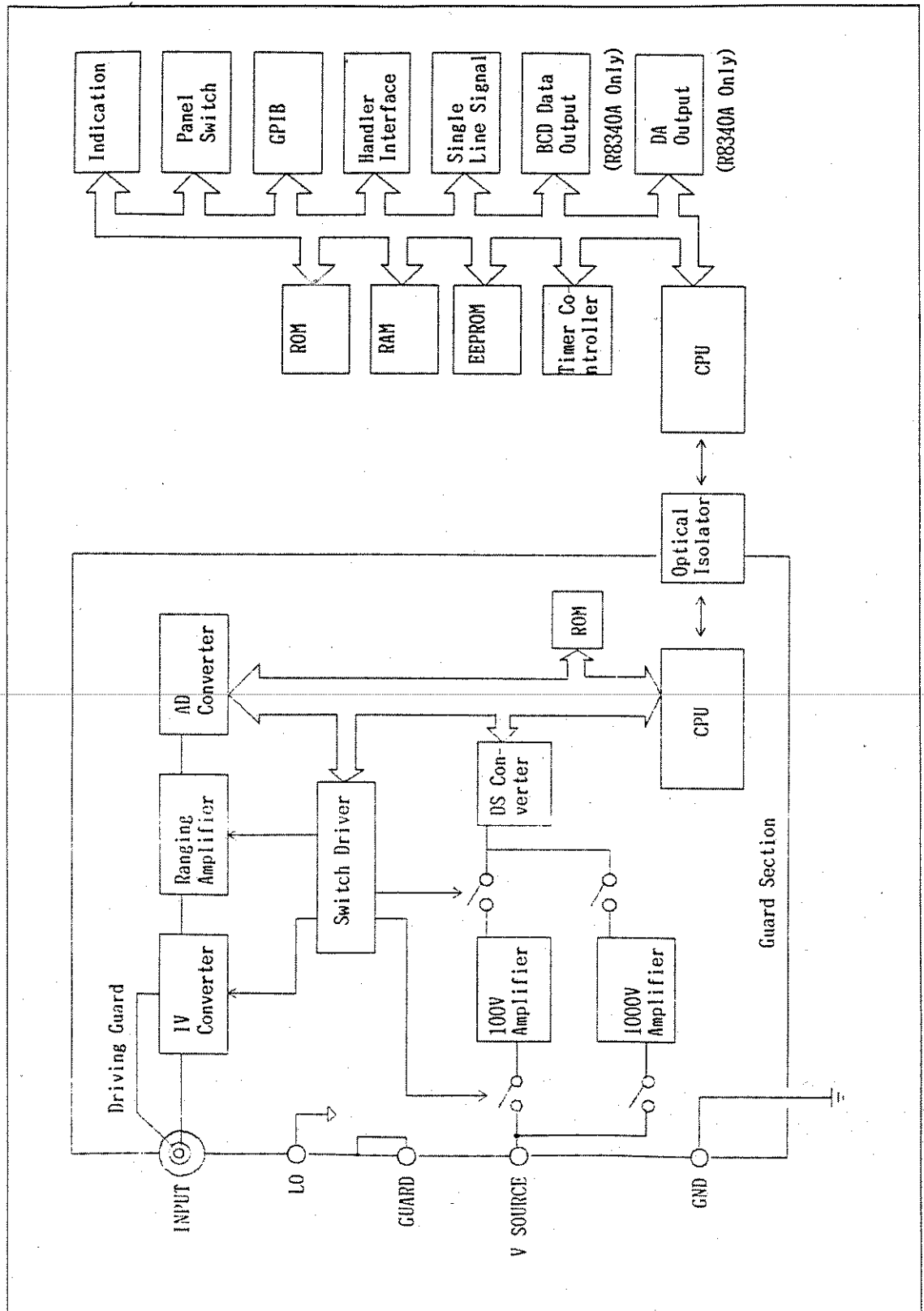

Figure 10 - 1 Block Diagram of R8340 and R8340A

## 10.2 IV Converter

Figure 10-2 shows the basic circuit diagram of the IV converter.

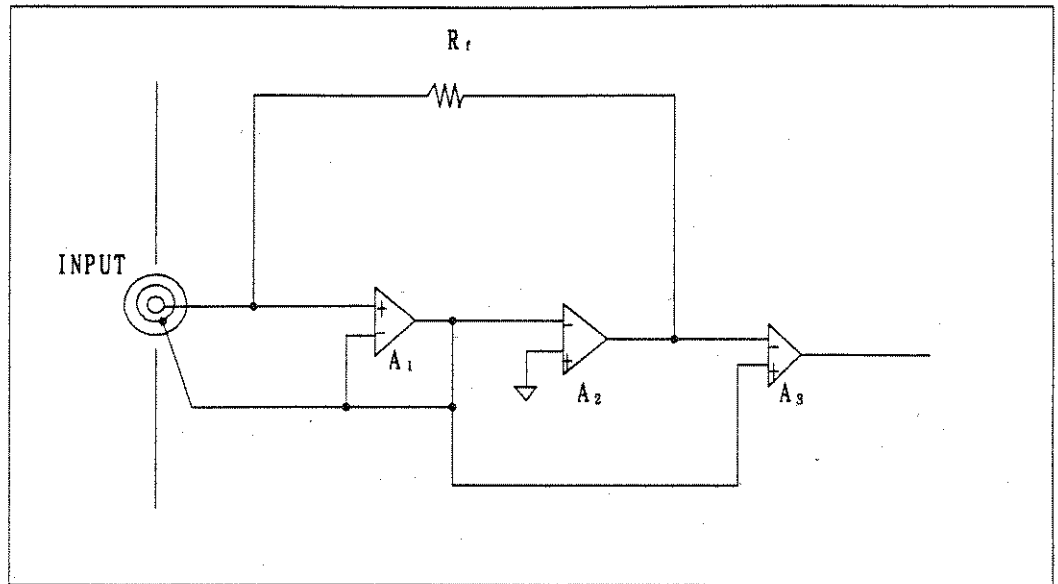

Figure 10 - 2 IV Converter

The amplifier A<sub>1</sub> functions as a buffer amplifier to obtain high input impedance and as a driving guard to guard input lines. The amplifier A<sub>2</sub> changes equivalent input resistance by changing the gain because the gain is variable. The amplifier A<sub>3</sub> is a differential amplifier to sense the voltage at the both ends of the resistor R<sub>f</sub>.

### 10.3 A/D Converter

The meter uses the input integration variable type A/D converter. By selecting the integration time of 200ms, 100ms, 20ms (for commercial power frequency of 50 Hz), or 2ms; it is possible to set stable measurement with a high noise-rejection ratio or highspeed sampling according to the measurement purpose. Figure 10-3 shows the outline of A/D converter operation.

When  $S_1$  is turned on and the input voltage  $V_{in}$  is integrated and a certain time elapses, the converter turns  $S_2$  on, applies the reference voltage  $V_{ref}$  until the integrator output is turned positive, and measures the duration if the output value of the integrator  $U_1$  is negative.

The converter repeats the above operation during the integration time and turns  $S_1$  off when the input integration time elapses. In addition, the converter keeps turning  $S_2$  on until the integrator polarity turns positive and ends the integration. The polarity of the integrator output is judged by the comparator  $U_2$  connected to the integrator output.

The results of counting the total time while  $S_2$  is turned on are used for the A/D conversion data.

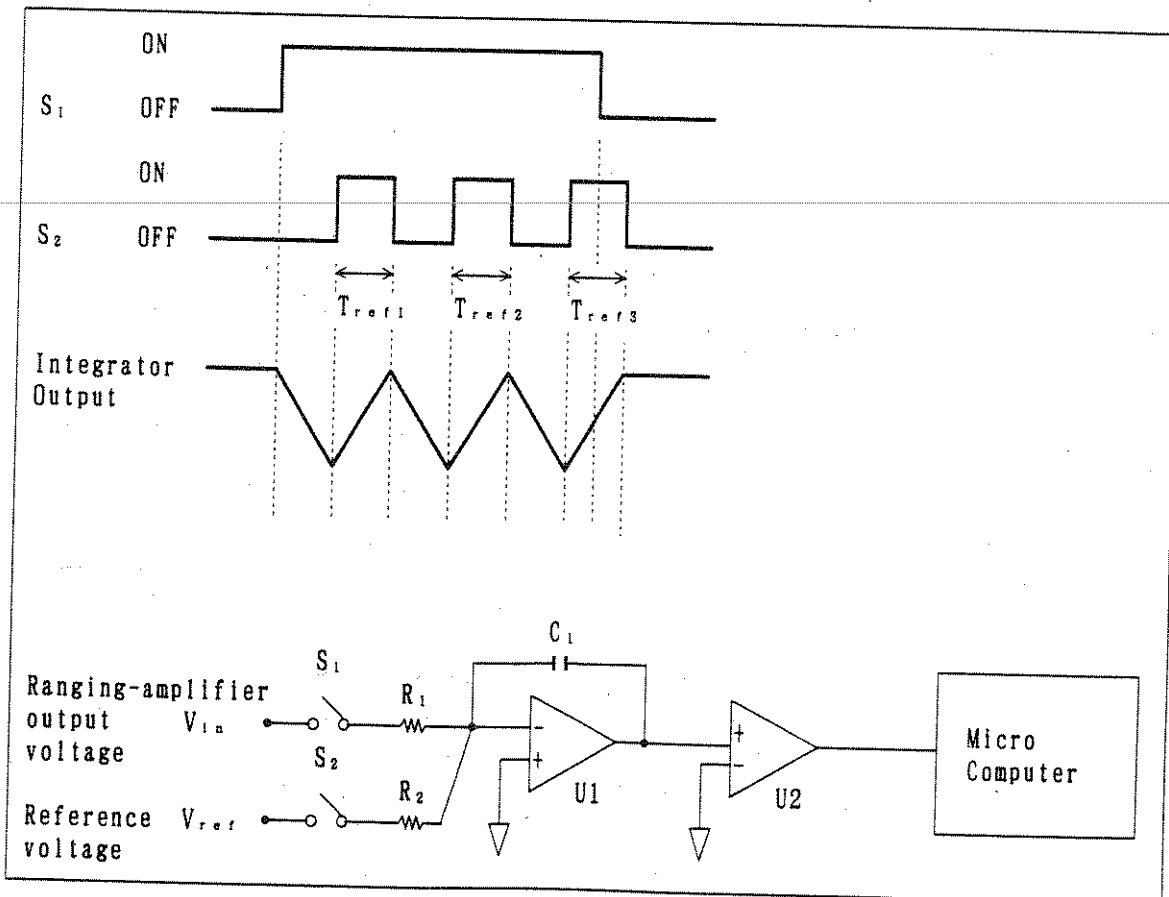

Figure 10 - 3 Outline of A/D Converter Operation

## 11. CONNECT INPUT/OUTPUT CABLES

This section describes the connection when the meter is combined with a fixture or scanner.

## 11.1 Connecting the Instrument to R12702A/B

The R12702A/B resistivity chamber is an electrode and shield chamber used for measuring volume resistance (ratio) and surface resistance (ratio) of sheet, film and panel type samples. The pressure of the electrodes can be adjusted to allow close connection of samples of any hardness. A dial gauge makes it possible to measure the thickness of the sample which is a requirement for calculating volume resistance. The chamber is also provided with a switch for selecting between volume and surface resistance and a switch which turns off and on the applied current as the lid is opened and closed.

R12702A :  $\phi$  50 electrode

R12702B :  $\phi$  70 electrode

Refer to section "3.2.6 Volume and Surface Resistivity measurements" for information on volume resistance (ratio) and surface resistance (ratio).

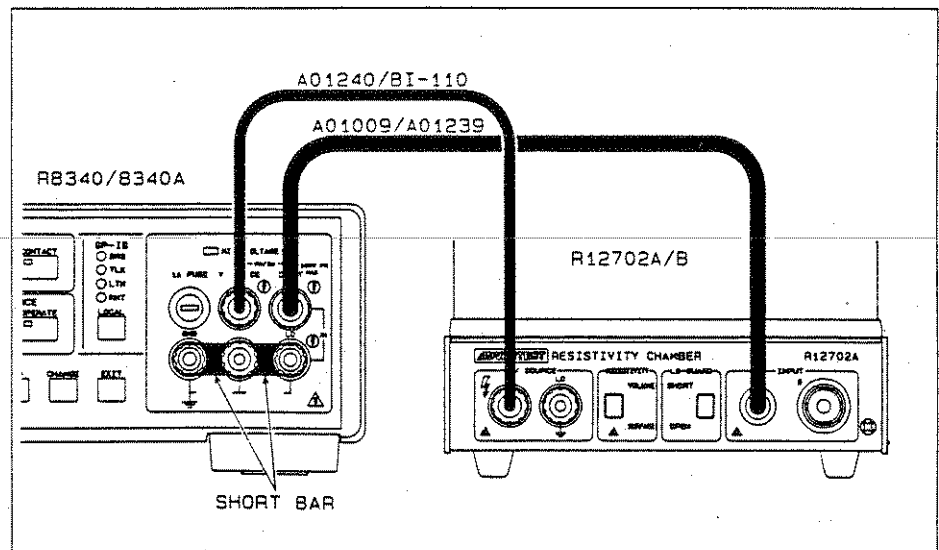

Figure 11 - 1 R12702A/B Setup

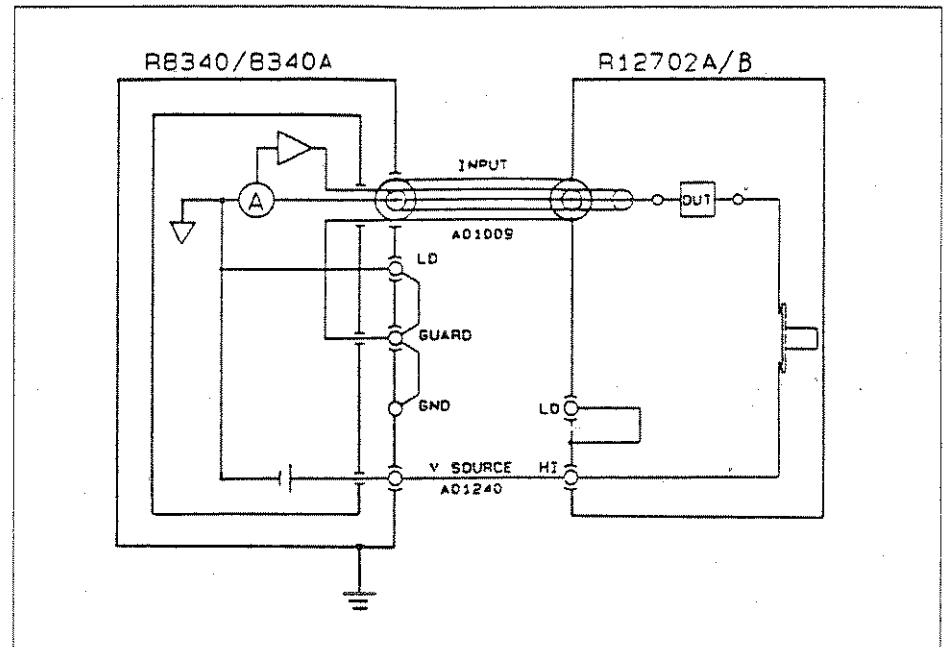

Figure 11 - 2 R12702A/B Connecting Diagram



11.2 Connecting the Instrument to R12704

The R12704 resistivity chamber is a shield chamber used for measuring volume resistance (ratio) and surface resistance (ratio) of shield insulated samples. Sample installation is easy. The chamber is also provided with a switch for selecting between volume and surface resistance and a switch which turns off and on the applied current as the lid is opened or closed. The diameter of the main electrode is 50  $\phi$ . Refer to section "3.2.6 Volume and Surface Resistivity Measurements" for information on volume resistance (ratio) and surface resistance (ratio).

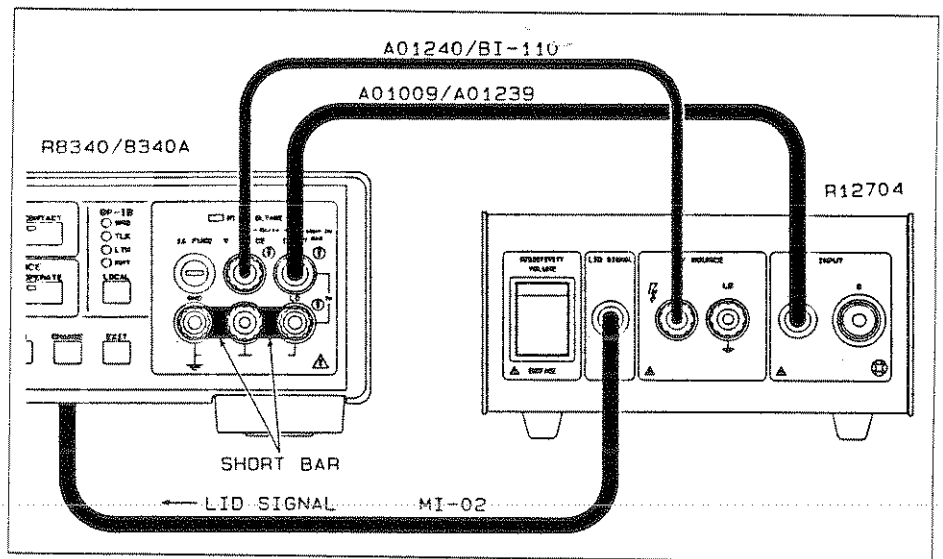

Figure 11 - 3 R12704 Setup

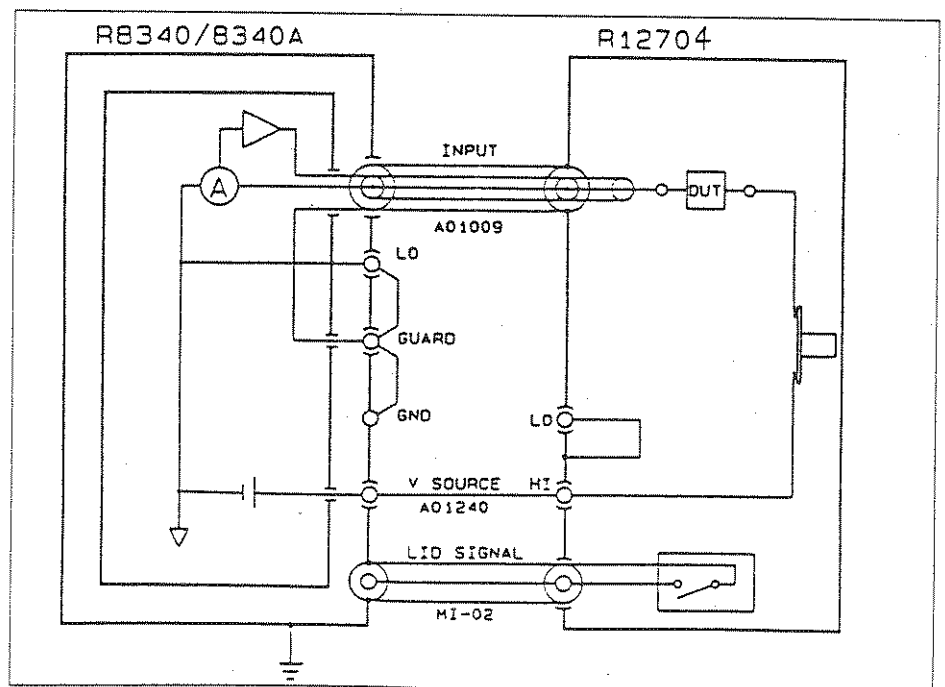

Figure 11 - 4 R12704 Connecting Diagram

## 11.3 Connecting the Instrument to TR42

The TR42 resistivity sample chamber is a shield box used for measuring volume resistance (ratio) and surface resistance (ratio) of shield insulated samples. A short bar is provided for selecting between volume and surface resistance. The internal electrode can be removed to allow measurement of samples with leads. The diameter of the main electrode is  $50\phi$ . Refer to section "3.2.6 Volume and Surface Resistivity Measurements" for information on volume resistance (ratio) and surface resistance (ratio).

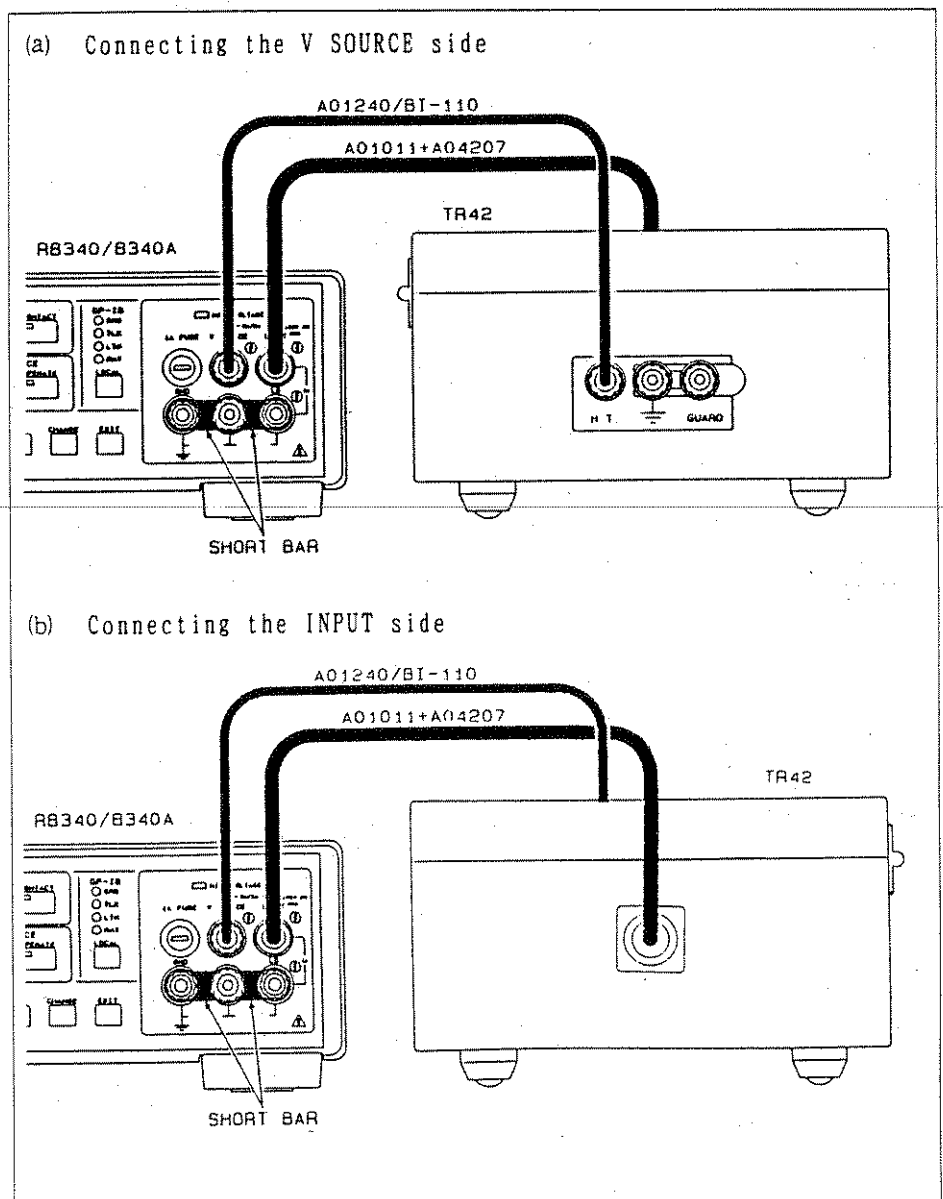

Figure 11 - 5 TR42 Setup  
(Measuring volume resistance)

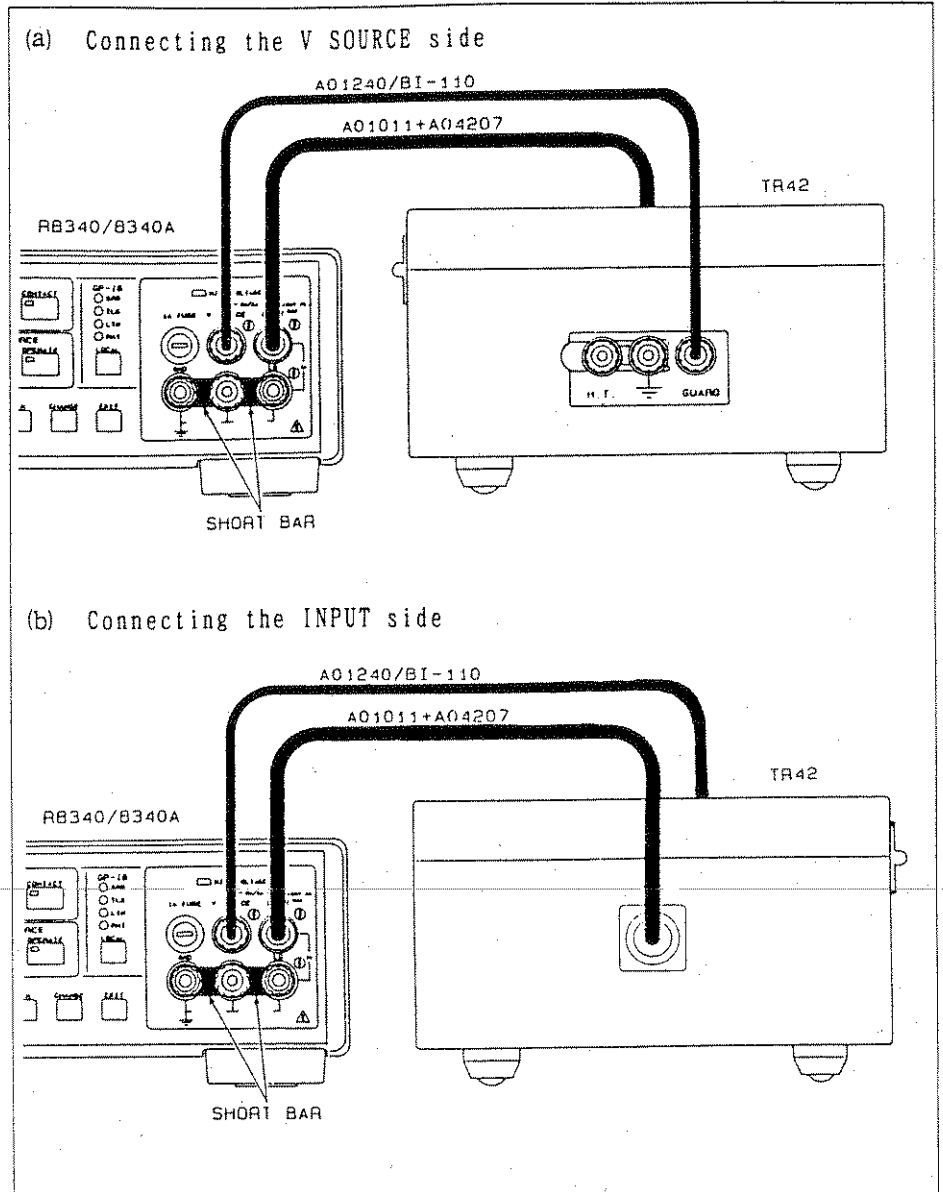

Figure 11 - 6 TR42 Setup  
(Surface resistance)

## 11.4 Connecting the Instrument to TR43C

Like the TR42, the TR43C is a sample chamber for measuring the volume and surface resistivity ratio of insulation samples. Continuous measurements of samples up to a temperature of 200°C is possible.

The diameter of the main electrode is 50φ.

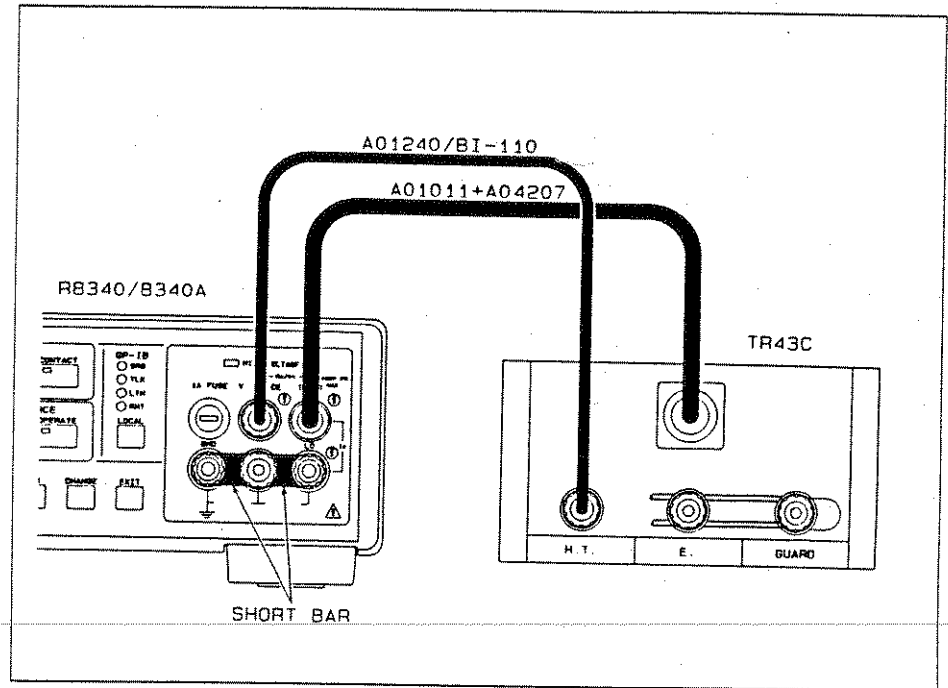

Figure 11 - 7 TR43C Setup

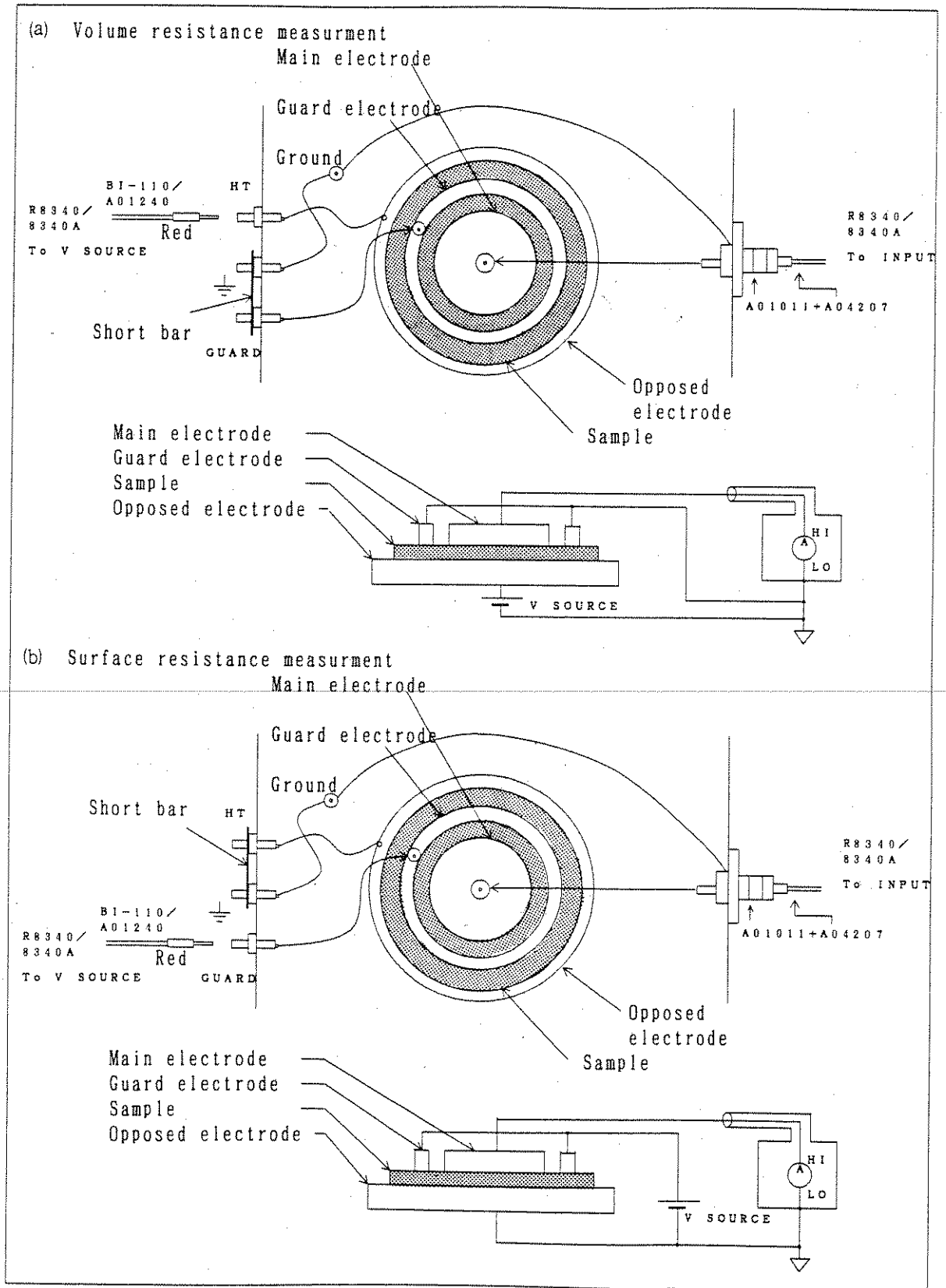

Figure 11 - 8 TR42 or 43C Internal Connecting Diagram

## 11.5 Connecting the Instrument to TR44

The TR44 is a sample chamber for measuring the volume resistance of insulating oil and liquid samples. The sample must have a volume of approximately 50cc.

Table 11 - 1 Coefficient Setting

Electrode setting	OPT	Refer to section "4.4.4 Setting of Volume-/Surface-Resistivity Electrode".
Electrode coefficient	637	Refer to section "4.4.5 Optional Electrode Coefficient".
Thickness	10	Refer to section "4.4.6 Sample Thickness".

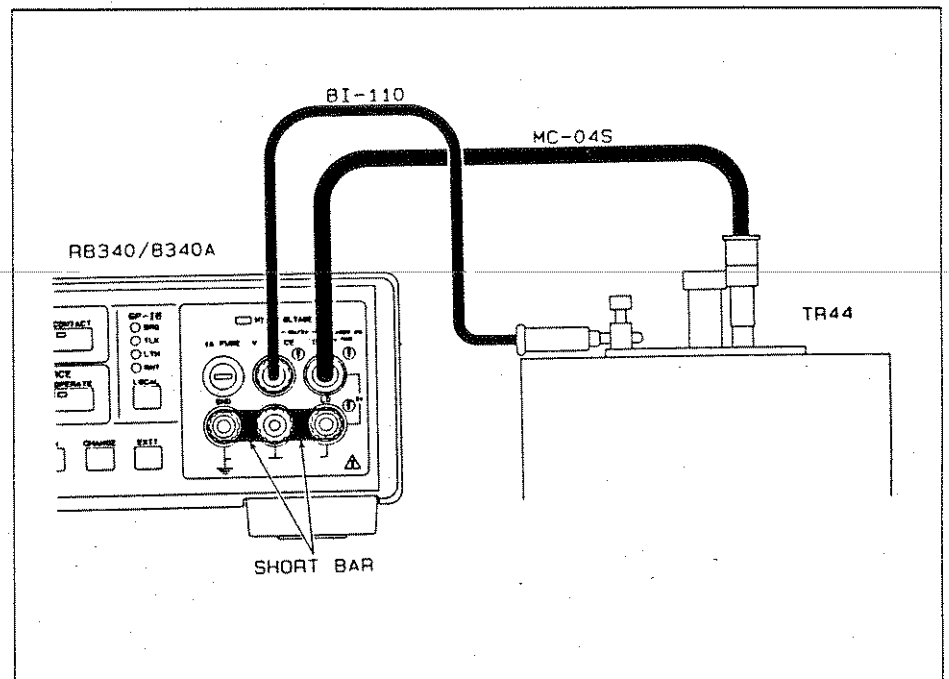

Figure 11 - 9 TR44 Setup

### 11.6 Connecting the Instrument to R12706A

The R12706A test fixture is a sample chamber for measuring the insulation resistance and voltage applied current of capacitors and diodes.

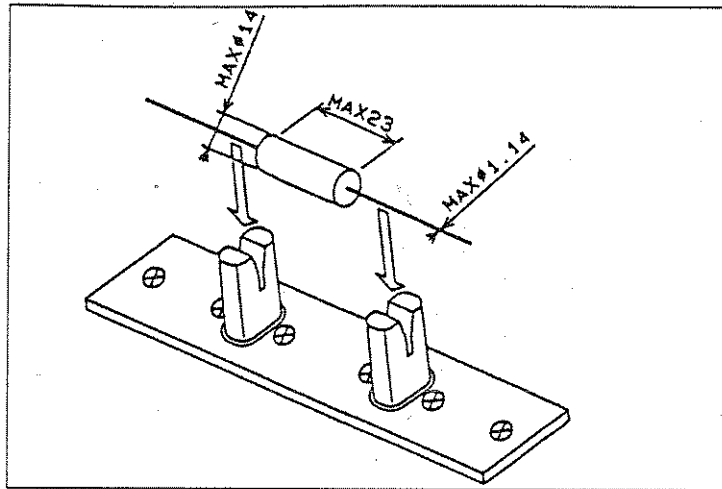

Figure 11 - 10 Installation Terminals

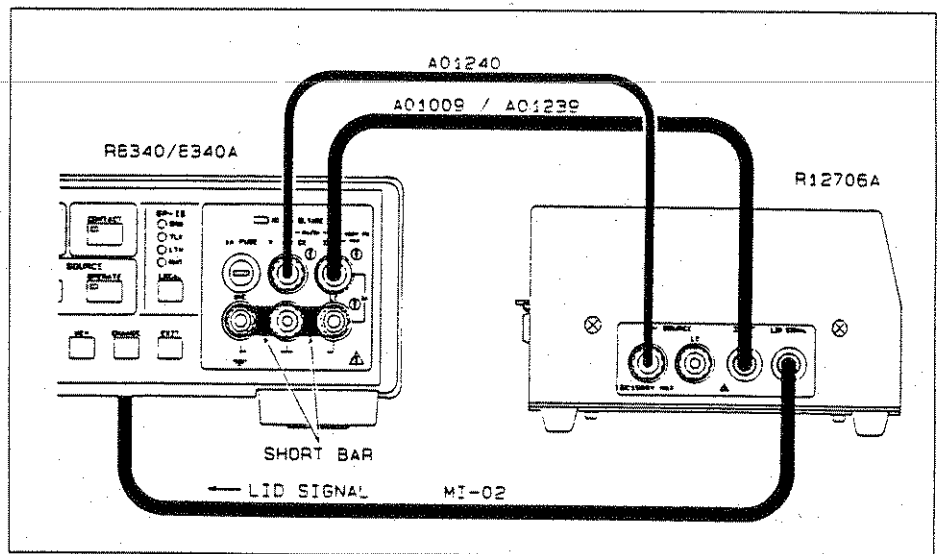

Figure 11 - 11 R12706A Setup

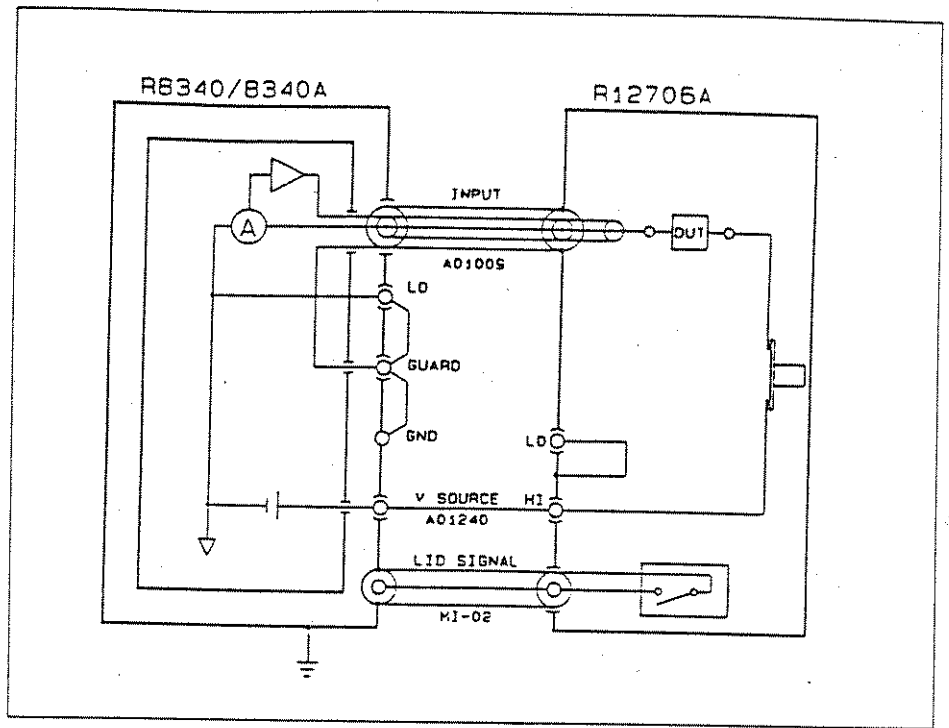

Figure 11 - 12 R12706A Connecting Diagram



### 11.7 Connecting Multiple Samples with R12705A, R7210 and R72101J

The R12705A 20CH test fixture is a sample chamber for measuring the insulation resistance and voltage applied current of capacitors and other electrical components. It allows the connection of up to 20 samples. It can be used with the R8340/8340A (measuring instrument), the R7210 and R72101J (scanner). In this configuration, the system can be controlled by a personal computer equipped with a GPIB interface to perform device evaluation, selection, edging and high-speed measurement simulations.

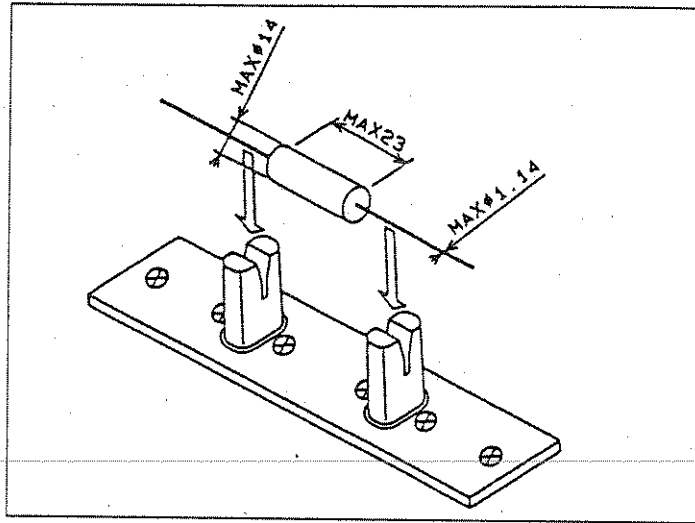

Figure 11 - 13 Installation Terminals.

11.7 Connecting Multiple Samples with R12705A, R7210 and R72101J

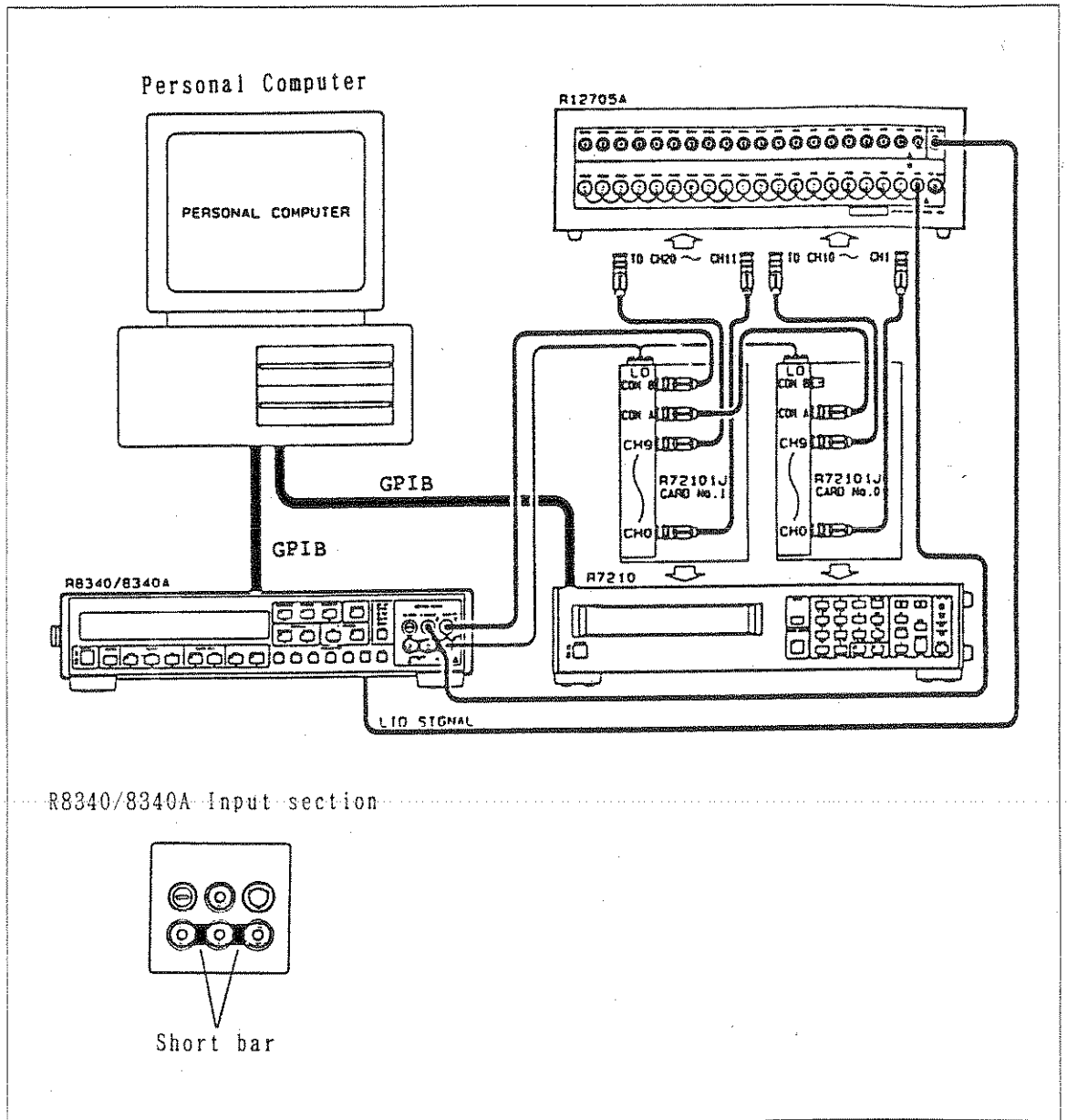

Figure 11 - 14 R12705A, R7210 and R72101J Setup

11.7 Connecting Multiple Samples with R12705A, R7210 and R72101J

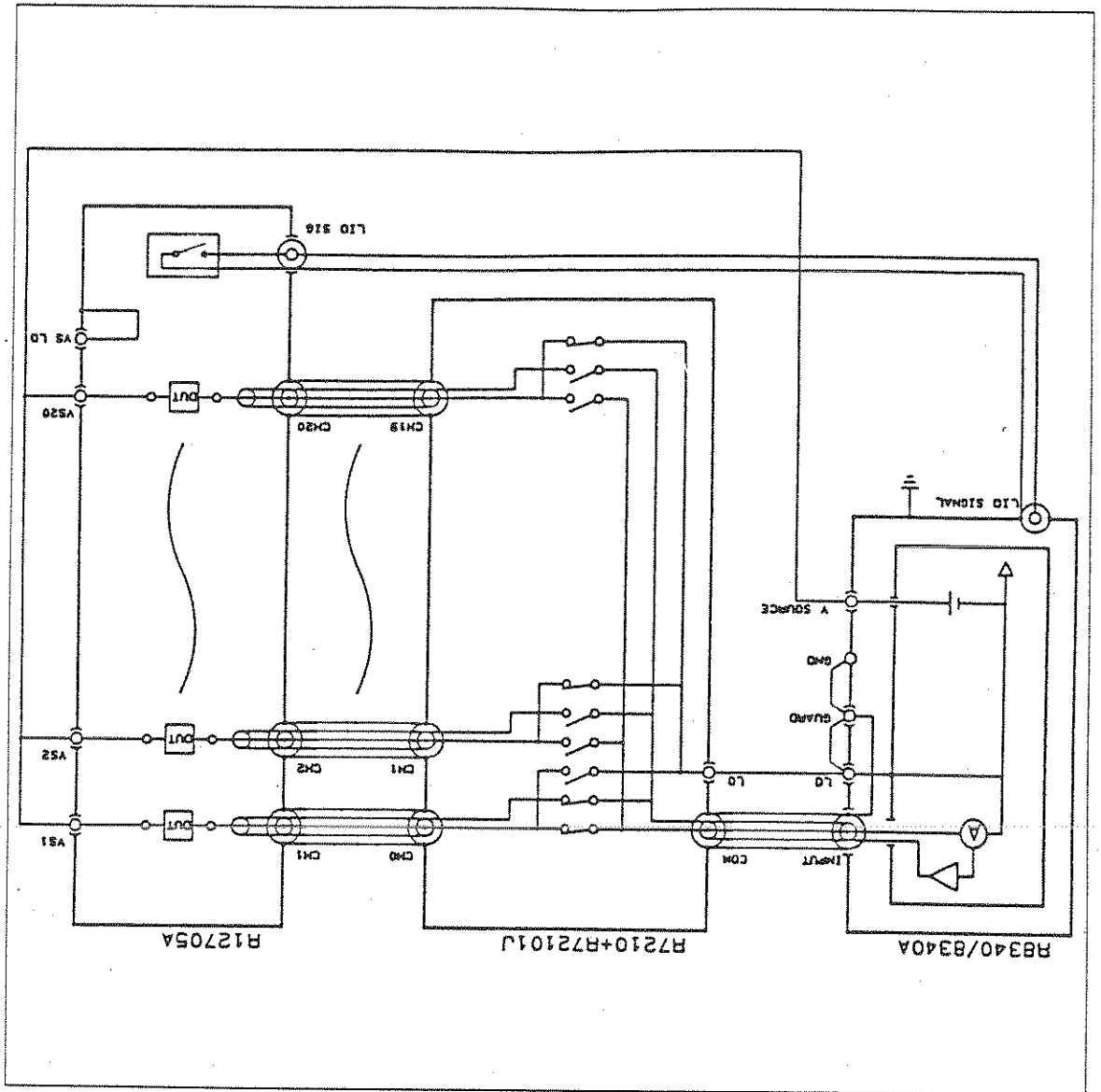

Figure 11 - 15 R12705A, R7210 and R72101J Connection Diagram

## 11.8 Connecting the Instrument to R12604

The R12604 tweezer probe is used for insulation resistance measurements of chip capacitors and other components. The tweezer type probe of the measurement probe and voltage application probe allows efficient measurement of small chip components. These kind of measurements should be performed on a shield plate to reduce the effect of induction noise. The A08076 Teflon insulated measuring shield plate (200 × 200mm) is provided as an option.

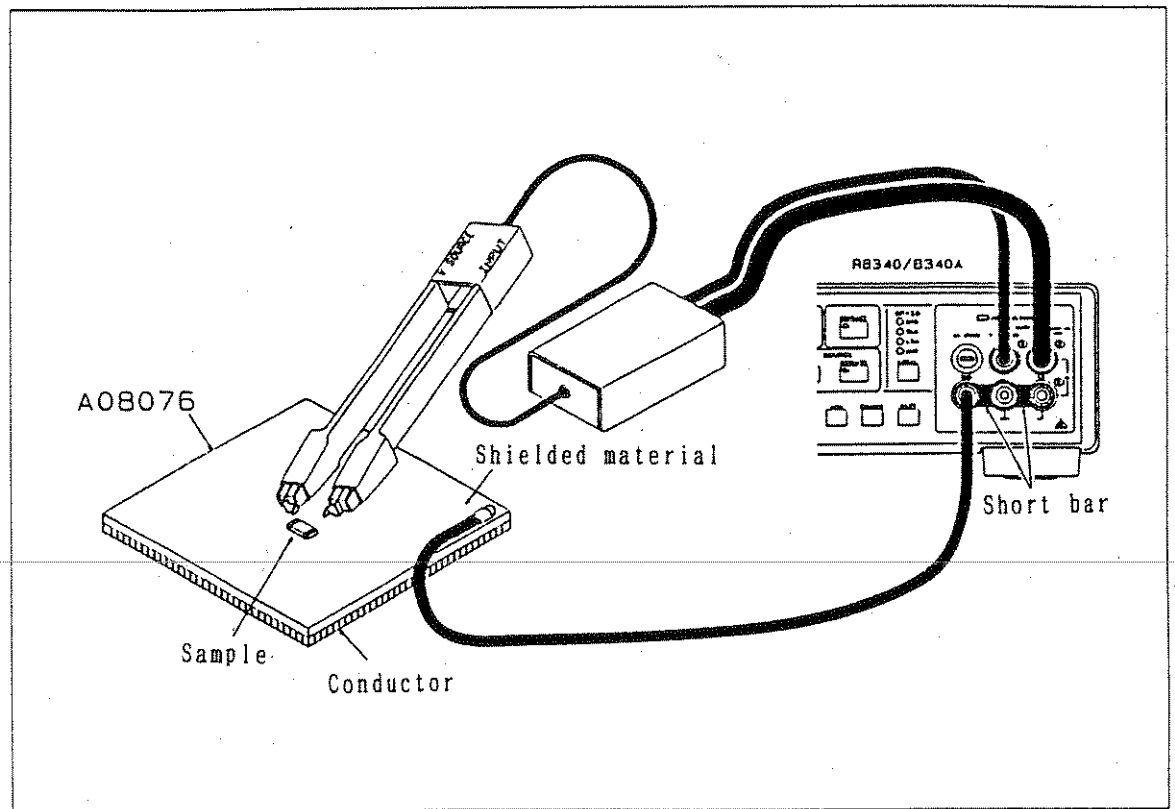

Figure 11 - 16 R12604 Setup

## 12. SPECIFICATION

This section summarizes the standards and accessories (optional) of the meter.

## 12.1 Direct Current Measurement

Measurement Range	Maximum Indication Value	Resolution	Measurement Accuracy $\pm$ (% of rdg+digit)	Temperature Coefficient $\pm$ (% of rdg+digit)/ $^{\circ}$ C	Settling Time
200pA	199.99pA	10fA	0.7 + 6d	0.02 + 0.5d	250mS
2nA	1999.9pA	100fA	0.7 + 3d	0.02 + 0.2d	25mS
20nA	19.999nA	1pA	0.3 + 3d	0.01 + 0.2d	5mS
200nA	199.99nA	10pA	0.3 + 3d	0.01 + 0.2d	
2 $\mu$ A	1999.9nA	100pA	0.15+ 3d	0.005+0.2d	2mS
20 $\mu$ A	19.999nA	1nA	0.15+ 2d	0.005+0.1d	
200 $\mu$ A	199.99 $\mu$	10nA	0.1 + 2d	0.005+0.1d	
2mA	1999.9 $\mu$ A	100nA	0.1 + 2d	0.005+0.1d	
20mA	19.999mA	1 $\mu$ A	0.1 + 2d	0.005+0.1d	

- The measurement accuracy is shown as the value for six months at the temperature of  $+23^{\circ}\text{C} \pm 5^{\circ}\text{C}$  and the relative humidity of 70% or less with the auto calibration set to ON converted into  $\pm$ (% of reading + digit)
- The temperature coefficient is shown as the value at the temperature of 0 to  $40^{\circ}\text{C}$  and the relative humidity of 70% or less converted into  $\pm$ (% of reading + digit)/ $^{\circ}\text{C}$
- The settling time shows the time until it reaches  $\pm 1\%$  of the final value when the input amplifier gain is set to " $\times 10000$ ", excluding the range changeover time.

## 12.2 Resistance Measurement

Current Range	Measurement Range ( $\Omega$ )	Measurement Accuracy (Example for VS of 100V and input amplifier gain of $\times 10$ or more)
200pA	$1 \times 10^9$ to $3 \times 10^{10}$	0.8% + 14d
2nA	$1 \times 10^8$ to $3 \times 10^{10}$	0.8% + 11d
20nA	$1 \times 10^7$ to $3 \times 10^{10}$	0.4% + 11d
200nA	$1 \times 10^6$ to $3 \times 10^{10}$	0.4% + 11d
2 $\mu$ A	$1 \times 10^5$ to $3 \times 10^{10}$	0.25% + 11d
20 $\mu$ A	$1 \times 10^4$ to $3 \times 10^{10}$	0.25% + 10d
200 $\mu$ A	$1 \times 10^3$ to $3 \times 10^{10}$	0.2% + 10d
2mA	$1 \times 10^2$ to $3 \times 10^9$	0.2% + 10d
20mA	$1 \times 10^1$ to $3 \times 10^9$	0.2% + 10d

## Measurement Accuracy

:  $\pm$  [(current-range reading term + 0.1% + input voltage drop/generated voltage) + (current-range digit term + voltage-generation digit term)]

## Temperature Coefficient

:  $\pm$  [(current-range reading term + 0.008%) /  $^{\circ}\text{C}$  + (current-range digit term + voltage-generation digit term) /  $^{\circ}\text{C}$ ]

## Maximum Indication Value

: 1 to 4 digits (1 to 9.999)

## Settling Time

: Follows the current measurement range.

## 12.3 Input Specification

### Input Resistance

Current range	input amplifier gain			
	×1	×10	×100	×10000
200pA	10GΩ	1GΩ	100MΩ	10KΩ or less
2nA	1GΩ	100MΩ	10MΩ	1KΩ or less
20nA	100MΩ	10MΩ	1MΩ	100Ω or less
200nA	10MΩ	1MΩ	100KΩ	11Ω or less
2 μ A	1MΩ	100KΩ	10KΩ	2Ω or less
20 μ A	100KΩ	10KΩ	1KΩ	1Ω or less
200 μ A	10KΩ	1KΩ	100Ω	1Ω or less
2mA	1.1KΩ	110Ω	11Ω	1Ω or less
20mA	180 Ω	18Ω	3Ω	1Ω or less

Input Voltage drop : ± (measured current x input resistance + 500 μ V)

Input bias current : 30 fA or less (At the temperature of +23°C ±1°C and the relative humidity of 50% or less)

Input capacitance : 30pF or less (Excluding the input cable)

Maximum allowable supply voltage  
 : 1.1kV peak



## 12.4 Direct Current Generation

Output voltage	Set resolution	Generation accuracy $\pm$ (% of setting + digit)	Temperature coefficient $\pm$ (% of setting + digit)/ $^{\circ}$ C	Output noise (10-500Hz)
0.000V to 10.000V	2.5mV	0.1 + 10d (10mV)	0.008 + 0.5d (500 $\mu$ V)	1mV p-p
10.03V to 100.00V	25mV	0.1 + 8d (80mV)	0.008 + 0.3d (3mV)	2mV p-p
100.3V to 1000.0V	250mV	0.1 + 8d (800mV)	0.008 + 0.3d (30mV)	5mV p-p

- The generation accuracy is shown as the value for six months at the temperature of  $+23^{\circ}\text{C} \pm 5^{\circ}\text{C}$  and the relative humidity of 70% or less converted into  $\pm$  (% of setting + digit).
- The temperature coefficient is shown as the value at the temperature of 0 to  $40^{\circ}\text{C}$  and the relative humidity of 70% or less converted into  $\pm$  (% of setting + digit)/ $^{\circ}\text{C}$ .

Output voltage	Current Compliance Setting		
	300mA	100mA	10mA
0.000V to 30.00V	$\pm 300\text{mA}$	$\pm 100\text{mA}$	$\pm 10\text{mA}$
30.03V to 100.00V	$\pm 100\text{mA}$	$\pm 100\text{mA}$	$\pm 10\text{mA}$
100.3V to 1000.0V	$\pm 10\text{mA}$	$\pm 10\text{mA}$	$\pm 10\text{mA}$

Current compliance accuracy (both source and sink) should be as shown below at the temperature of  $+23^{\circ}\text{C} \pm 5^{\circ}\text{C}$  and the relative humidity of 70% or less:

300mA:  $\pm 300\text{mA}$  to  $\pm 500\text{mA}$

100mA:  $\pm 100\text{mA}$  to  $\pm 150\text{mA}$

10mA:  $\pm 10\text{mA}$  to  $\pm 20\text{mA}$

Settling time : Genuine resistance load  $t=3\text{ms}(\text{MAX})$

Capacitive load

$$t = \underbrace{\frac{CV}{I}} + \underbrace{t_0}$$

Charge time      Converging time

t : Settling time (the time it takes to reach  $\pm 1\%$  of the value excluding the time required for range switching)

C : Load capacity

V : Output voltage

i : Charge current (the maximum value is the compliance value)

t<sub>0</sub> : Convergence time (see table below)

Output voltage \ Capacity	Capacity		
	0.22 $\mu$ F	22 $\mu$ F	33 $\mu$ F
0.000V to 100.00V	0.1	3.0	7.0
100.3V to 1000.0V	4.2	15	150

(msec)

Overshoot voltage :

Load Output voltage	Genuine resistance	Capacity		
		0.22 $\mu$ F	2.2 $\mu$ F	33 $\mu$ F
0.000V to 100.00V	0.05	0.05	3.0	3.0
100.3V to 10000. V	0.05	36	24	10

(V)

12.5 Measurement Speed and  
Maximum Indication  
(For Current Measurement)

Integration time	Sample size for free run	Maximum indocation
2mS	100 times/sec	3½ digits 1999
1PLC	50Hz times/sec 60Hz times/sec	4½ digits 19999
5PLC	8.5 times/sec	
10PLC	4.5 times/sec	
4×10PLC	1 times/sec	
8×10PLC	0.5 times/sec	
16×10PLC	0.3 times/sec	

\*1: When indication is set to OFF, auto calibration to OFF, and memory store to ON.

## 12.6 Input/Output Function

GPIB ; Follows IEEE std 488-1978.

It is possible to output measured data, generated voltage, status, and error messages.

It is possible to use the binary packed format (IEEE 754, Floating point).

Handler interface ;

Input/output signals timing with such external equipment as the auto handler and fixture (24-pin Amphenol connector)

Input ; \*TRIGGER, LID SIGNAL, \*CONTACT START

output ; \*COMPLETE, \*EOM, \*INDEX, \*ALARM, \*LO, \*GO, \*HI, \*NO CONTACT

Single wire signal (BNC connector)

\*TRIGGER (Input)

LID SIGNAL (Input)

\*COMPLETE (Output)

BCD OUTPUT (Given to only R8340A);

Makes it possible to select the OFF, BCD or BINARY output format. (50-pin Amphenol connector), TTL positive logic

D/A OUTPUT (Given to only R8340A);

Two or three optional digits of indicated data are DA-converted and output.

Output voltage ;  $\pm 1V$

Conversion output ; Three-digit indication 000 to  $\pm 999 \rightarrow$   
0V to  $\pm 0.999V$   
Setting of 50% offset is possible.  
Output for offset (-500  $\rightarrow$  0V, 000  $\rightarrow$  0.5V,  
+499  $\rightarrow$  0.999V)

Digit selection ; 19999 19999 19999 19999

Conversion accuracy ;  $\pm 0.2\% \pm 2d$   
(Guaranteed for six months at the temperature of  $+23^{\circ}C \pm 5^{\circ}C$  and the relative humidity of 70%)

Output resistance ;  $1\Omega$  or less

Maximum load current ;  $\pm 0.5mA$

Output connector ; Binding post

## 12.7 Other Function

### NULL

$R = X - X_{NULL}$

The measured data when NULL is set is subtracted from measured data.

X; Measured value,  $X_{NULL}$ ; Measured data when NULL is set

### COMPARE

R(Hi) ;  $X > Y$

R(Go) ;  $Y \geq X \geq Z$

R(Lo) ;  $X < Z$

Measured data is compared with set data.

X; Measured value, Y; High-level set value, Z; Low-level set value

### PRGM (Sequence program)

Typical sequence including capacitor lead measurement and JIS C5102 are stored.

Setting item IS ; Automatic start current value

TC ; Charge time

TD ; Discharge time

TM ; measurement time

### CONTACT(Contact checking)

Sample contact state is checked through C-measurement. Missing capacitance of capacitors can also be checked by initializing the standard sample.

Setting item ; Contact level. To be judged with n-fold of standard sample.

### AUTO RANGE LEVEL

Auto range for current measurement can be selected in the following three types ; 20000, 2000, and 200 for UP and 1799, 179, and 17 for DOWN.

This allows high-speed response measurement corresponding to necessary number of digits.

### DATA MEMORY

One thousand data values can be memorized.

### BUZZER

The buzzer sounds in two tones (high-and low-pitched tones) for HI/Lo for COMPARE operation results, end of program, error detection.

12.8 General Specification

Normal-mode noise rejection ratio  
: (For 50/60Hz ±0.09%)

INTEGRATION TIME	NMRR	ECMRR
2ms	0dB	60dB or more
1PLC to 16×10PLC	60dB以上	120dB or more

Effective-common-mode noise rejection ratio  
: Above ECMRR(At DC and 50/60Hz±0.09% for 1kΩ unbalanced impedance between LO and GND terminals)

Measuring System : Integration System  
Input System : Floating System  
Data Indication : Seven-segment green LED  
Unit/Exponent Indication : 5×7 dot matrix green LED  
Input Terminal : TRIAXIAL Connector (INPUT)  
Black binding post (LO, GND)  
Blue binding post (GUARD)  
Voltage Output Terminal : Red binding post (V SOURCE)

Input Protection Fuse : 1A Fuse

Maximum application voltage between terminals :

INPUT ..... Between INPUT terminal and other terminals ; 1100V peak (for 1 min)

LO ..... Between LO and GUARD terminals ; 550V peak (1100V peak for R8340A)

LO ..... Between LO and GND terminals ; 550V peak (1100V peak for R8340A)

GUARD ..... Between GUARD and GND terminals ; 1100V peak

V SOURCE ..... Between V-SOURCE and other terminals ; 100Vpeak (Set voltage of 0 to 100.0V), 1000Vpeak(Set voltage of 100.03 to 1000.0V)

Preheating time : Approx. 30min(Until measured value falls into the specified accuracy)

Operating environment range

: Temperature of 0 to 40°C, Relative humidity of 85% or less

Storing environment range

: -25°C to +70°C

Power supply

: Set to the value specified when you ordered

Option No.	Standard	31	32	42	43	44
Supply Voltage	90 to 110	103 to 127	108 to 132	198 to 242	207 to 250	216 to 250
Power Frequency	48 to 66Hz					

Power consumption : 90VA or less

Outside dimensions : Approx. 424(Width)x88(Height)x350(Depth)mm

Weight : 8kg or less

## 12.9 Accessories (Optional)

### (1) Equipment

R12701 test fixture  
R12702A/B resistivity chamber  
(Variable pressure, Thickness measurement)  
R12704 resistivity chamber  
TR42 ultra-high resistance measurement sample case  
TR43 ultra-high resistance measurement sample case  
(For high temperature)  
TR44 liquid resistance measurement sample container  
R12603 test lead

### (2) Input Cable

A01009-50, -100, -150, -200 (TRIAx-TRIAx connector)  
MC-04SX01, X02, X03, X04, X05 (TRIAx-TR44 connection)  
A01239-50, -100, -150, -200 (High-dielectric-strength TREAX  
-TRIAx connector)  
A01011-50, -100, -150, -200 (TRIAx-BNC connector)  
A04207 (BNCJ-MP adapter)

APPENDIX

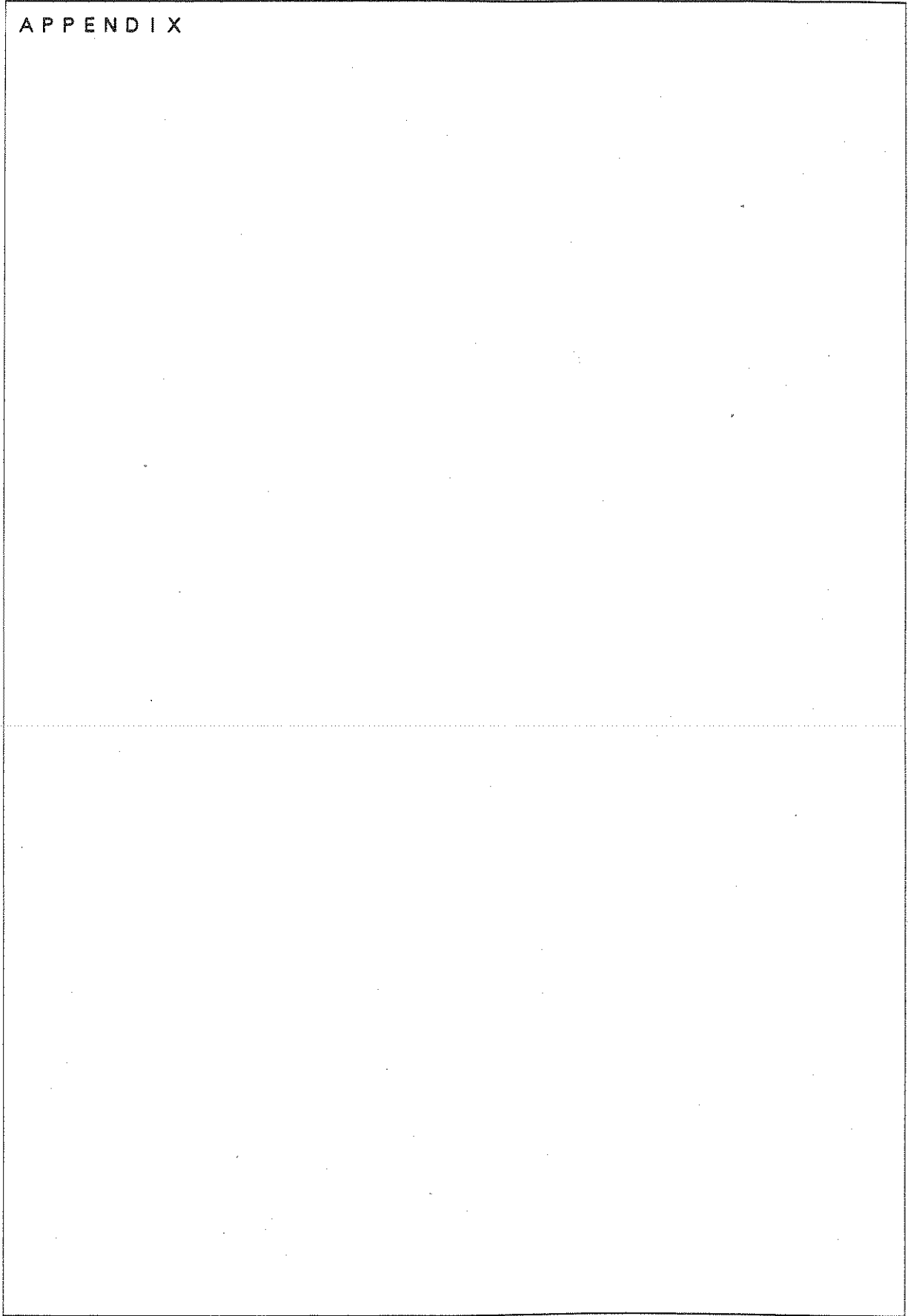



### A1.1 GPIB Remote Execution Time (representative value)

Applicable computer ; HP9000 series, Model 216, BASIC 2.0

Program code execution time

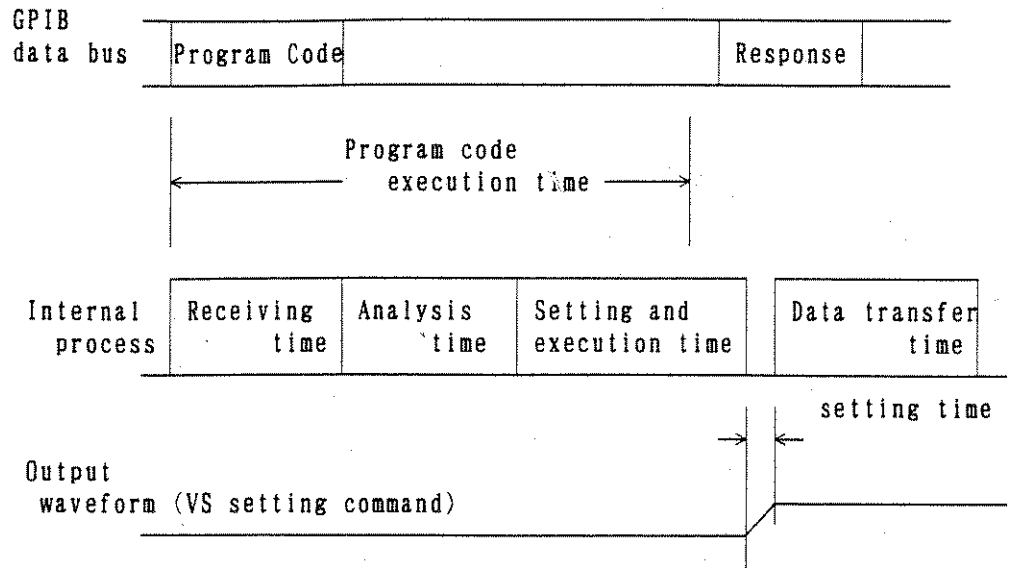

#### (1) VS Setting

Program code	Receiving and analysis time	Setting time	Total (representative value)	Measurement condition
PVS10.000	3ms	2.0ms	5.0ms	Operate
PVS100.00	3ms	17.0ms	20.0ms	
PVS1000.0	3ms	16.0ms	19.0ms	

※ The setting time is not included.

#### (2) Setting Operate/Standby

Program code	Receiving and analysis time	Setting time	Total (representative value)
DTX	2.0ms	13.5ms	15.5ms

## (3) Contact check (When the contact initial integral time is 2ms)

Program code	Receiving and analysis time	Execution time	Data transfer time	Total (representative value)	Measurement condition
CNT?	2.0ms	51.5ms	0.6ms	54.1ms	Charge mode

## (4) C, Z command

Program code	Receiving and analysis time	Execution time	Total (representative value)
C	1.3ms	619ms	620.3ms
Z	1.4ms	832ms	833.4ms

## (5) Change-over of range

The range change-over time is calculated by adding the receiving and analysis time and execution time described below.

Program code	Receiving and analysis time
R2 to R9	1.7ms
R10	2.0ms

Execution time (representative value) [Unit:ms]

Before modification After modification	200pA	2nA	20nA	200nA	2 $\mu$ A	20 $\mu$ A	200 $\mu$ A	2mA	20mA
200pA		10.4	10.4	10.4	10.4	10.4	10.4	10.4	10.4
2nA	10.3		10.4	10.4	10.4	10.4	10.4	10.4	10.4
20nA	10.3	10.4		10.4	10.4	10.4	10.4	10.4	10.4
200nA	10.3	24.5	16.4		10.4	10.4	10.4	10.4	10.4
2 $\mu$ A	10.4	24.5	30.5	16.4		10.4	10.4	10.4	10.4
20 $\mu$ A	10.3	24.5	30.5	16.4	10.4		8.3	8.3	8.3
200 $\mu$ A	10.3	24.5	30.5	16.4	10.4	8.3		8.3	8.3
2mA	10.3	24.5	30.5	16.4	10.4	8.3	8.3		8.3
20mA	10.3	24.5	30.5	16.4	10.4	8.3	8.3	8.3	

Measurement execution time (HOLD-TRIGGER)

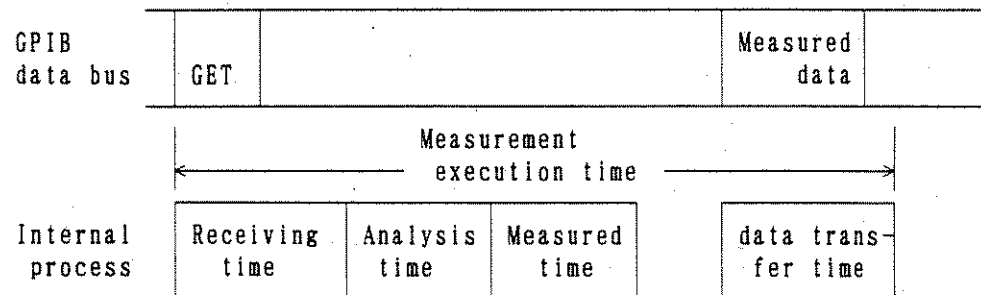

Measurement of current	Receiving and analysis time	Measurement time	Data trans- fer time	Total (repre- sentative value)	Measurement condition
2ms	0.5ms	9.8ms	3.8ms	14.1ms	Measurement of current NULL OFF COMPARE OFF AD CAL OFF STORE OFF Data output mode OMO
1PLC	0.5ms	27.8ms	3.8ms	32.1ms	

I N D E X

[ A ]

A display .....	2 - 8
A/D Converter .....	10 - 5
Accessories (Optional) .....	12 - 11
Accessories .....	1 - 5
AD CAL (MEAS key) .....	4 - 10
AD CAL .....	3 - 35
Adapter .....	1 - 8
Address Setting .....	6 - 6
APPLIED MEASUREMENT .....	11 - 1
AUTO key .....	2 - 3
AUTO RANGE LEVEL .....	12 - 9
Auto Range Up/down Level .....	4 - 13
(MEAS key)	
Auto Range Up/Down Level .....	3 - 41
Autorange Delay (MEAS key) .....	4 - 16
Autorange Delay .....	3 - 51

[ B ]

Basic Format .....	6 - 7
BCD OUTPUT (I/O key) .....	4 - 43
BCD OUTPUT connector .....	2 - 9
BCD Output .....	8 - 1
.....	8 - 2
Before Requesting Repair .....	8 - 2
Binary Output .....	8 - 7
Binary Packed Format .....	6 - 11
Block Diagram .....	10 - 3
bus cable .....	6 - 5
Buzzer (COEF key) .....	4 - 37
BUZZER .....	12 - 9

[ C ]

Cable .....	1 - 10
CAL key .....	4 - 4
Calibration Data	
Initialization .....	8 - 5
Calibration Method .....	8 - 6
Calibration state .....	3 - 9
Calibration .....	8 - 3
CHARGE key .....	2 - 4
Charge .....	3 - 16
COEF key .....	4 - 5
Command Buffer .....	6 - 24
COMPARE key .....	2 - 4
Compare .....	3 - 34
.....	12 - 9

COMPLETE OUTPUT connector .....	2 - 9
COMPLETE Output Signal .....	7 - 9
Connection for Coexistence of Isolated and Earthed Samples .....	3 - 14
Connection of Earthed Sample .....	3 - 12
Connection of Isolated Sample .....	3 - 11
Contact Checking .....	3 - 43
.....	12 - 9
Contact Initial Integral Time (COEF key) .....	4 - 39
Contact Initialization (CAL key) .....	4 - 19
Contact Initialization Offset Measurement (CAL key) .....	4 - 18
CONTACT key .....	2 - 4
Contact Level (COEF key) .....	4 - 35
CONTACT .....	12 - 9
Controller Interruption .....	6 - 24
Current Compliance (MEAS key) .....	4 - 12
Current Compliance .....	3 - 40
Current Limiter (MEAS key) .....	4 - 12
Current Limiter .....	3 - 40

[ D ]

D/A Output .....	8 - 1
.....	8 - 10
DA OUTPUT (I/O key) .....	4 - 41
DA OUTPUT connector .....	2 - 9
Data Indicator (COEF key) .....	4 - 38
DATA MEMORY .....	12 - 9
Data Output .....	6 - 7
Data Part .....	6 - 15
Data Recall (MEM key) .....	4 - 49
Data Storage (MEM key) .....	4 - 47
DC Measurement .....	3 - 17
DESCRIPTION OF OPERATION .....	10 - 1
Device Event Status Register .....	6 - 30
Direct Current Generation .....	12 - 5
Direct Current Measurement .....	12 - 2
DISCHARGE key .....	2 - 4
Discharge .....	3 - 15
DOWN key .....	2 - 3

## [ E ]

Error Messages .....	3 - 8
Error Register .....	6 - 32
Execution of Sequence Program .....	5 - 8
EXT CAL switch .....	2 - 9

## [ F ]

Format of Recall Data with Data Number .....	6 - 12
Front Panel .....	2 - 3
Fuse holder .....	2 - 5
	2 - 9
Fuse Open Detection Message .....	3 - 5
Fuse .....	1 - 9

## [ G ]

General Specification .....	12 - 10
Generated voltage indicator .....	2 - 8
GND terminal .....	2 - 5
	2 - 9
GPIB (I/O key) .....	4 - 44
GPIB connector .....	2 - 9
GPIB remote execution time .....	A1 - 2
GPIB Standard .....	6 - 3
GPIB status lamp .....	2 - 4
GPIB system .....	6 - 5
GUARD terminal .....	2 - 5

## [ H ]

HANDLER INTERFACE connector .....	2 - 9
Handler Interface .....	7 - 2
Header on/off Selection .....	6 - 6
Header Part .....	6 - 14
HIGH VOLTAGE lamp .....	2 - 5
How to Set Auto-start Value .....	5 - 15
How to Set Charge Time .....	5 - 15
How to Set Discharge Time .....	5 - 17
How to Set measurement time .....	5 - 18

## [ I ]

I/O key .....	4 - 4
IM/RM key .....	2 - 3
IM .....	3 - 17
Initialize Setting States .....	3 - 9
Input Amplifier Gain (MEAS key) .....	4 - 11
Input Amplifier Gain .....	3 - 36
INPUT connector .....	2 - 5
Input Error .....	3 - 7
Input Resistance .....	3 - 39
Input Specification .....	12 - 4
Input Voltage Drop .....	3 - 39
Input/Output Cable .....	1 - 10
Input/Output Function .....	12 - 8
INPUT/OUTPUT SIGNALS .....	7 - 1
Integral Time (MEAS key) .....	4 - 8
Integration Time .....	3 - 35
IV Converter .....	10 - 4

## [ L ]

LID SIGNAL INPUT connector .....	2 - 9
LID SIGNAL Input Signal .....	7 - 11
LIMIT display .....	2 - 8
Limiter Message .....	3 - 6
Listener Specification .....	6 - 14
LO terminal .....	2 - 5
LO, GO, and HI display .....	2 - 8
LOCAL key .....	2 - 4
LOWER Level (COEF key) .....	4 - 26
LTN lamp .....	2 - 5

## [ M ]

MEAS key .....	4 - 3
MEASURE key .....	2 - 4
Measured Data Buffer .....	6 - 24
Measured value indicator .....	2 - 8
Measurement of Surface Resistivity .....	3 - 26
Measurement of Volume Resistivity .....	3 - 26
Measurement Speed and Maximum Indication .....	12 - 7
Measuring Multiple Samples .....	11 - 12
MEM key .....	4 - 6
Mesure .....	3 - 16

## [N]

Normal state .....	3 - 9
NULL key .....	2 - 4
Null .....	3 - 33
	12 - 9

## [O]

OPERATE key .....	2 - 4
Operating Ambient Condition .....	1 - 6
Optional Electrode Coefficient (COEF key) .....	4 - 32
Over-range Message .....	3 - 4
Overheat Detection Message .....	3 - 7
Overload Message .....	3 - 4
Overvoltage Detection Message .....	3 - 6

## [P]

Parameter Key Functions .....	2 - 6
	4 - 3
PARAMETER key .....	2 - 5
Plug .....	1 - 8
Power Cable .....	1 - 8
Power connector .....	2 - 9
Power Frequency (I/O key) .....	4 - 46
Power On .....	3 - 2
POWER switch .....	2 - 3
Preheating Time .....	1 - 10
PRGM/NORMAL key .....	2 - 4
PRGM .....	12 - 9
Program Code .....	6 - 16
Program Example .....	6 - 35
Program No. 0 .....	5 - 2
Program No. 1 .....	5 - 3
Program No. 2 .....	5 - 4
Program No. 3 .....	5 - 5
Program No. 4 .....	5 - 6
Program No. 5 .....	5 - 7

## [Q]

Query Command .....	6 - 15
---------------------	--------

## [R]

R12604 Setup .....	11 - 15
R12702A/B Setup .....	11 - 2
R12704 Setup .....	11 - 4
R12706A Setup .....	11 - 10
Rear Panel .....	2 - 9
Resistance Measurement Indication (COEF key) .....	4 - 30
Resistance Measurement .....	3 - 22
	12 - 3
Resistance Operation Error Message .....	3 - 5
Response to Query Command .....	6 - 9
RMT lamp .....	2 - 5
RUN/HOLD key .....	2 - 3

## [S]

S display .....	2 - 8
Safety Symbols .....	2 - 2
Sample Thickness (COEF key) .....	4 - 34
Sampling indicator .....	2 - 8
Self-test (CAL key) .....	4 - 20
Self-test Error Register .....	6 - 33
Sequence Program Operation Example .....	5 - 19
Sequence program .....	12 - 9
Sequence .....	5 - 2
SET key .....	2 - 4
Setting of Program Parameters .....	5 - 12
Setting of Volume-/ Surface-Resistivity Electrode (COEF key) .....	4 - 31
SPECIFICATION .....	12 - 1
SRQ lamp .....	2 - 4
Standard Accessories .....	1 - 5
Standard Bus Cable .....	6 - 5
Standard Event Status Register .....	6 - 28
START key .....	2 - 4
Status Byte Register .....	6 - 25
Supply Voltage .....	1 - 7
SURF display .....	2 - 8

## [ T ]

Talker Specification .....	6 - 7
Terminator .....	6 - 15
TLK lamp .....	2 - 4
TR42 Setup .....	11 - 5
TR43C Setup .....	11 - 7
TR44 Setup .....	11 - 9
TRIG key .....	2 - 3
Trigger Delay (MEAS key) .....	4 - 15
Trigger Delay .....	3 - 50
TRIGGER INPUT connector .....	2 - 9
TRIGGER Input Signal .....	7 - 10

## [ U ]

Unit Indication (MEAS key) .....	4 - 14
Unit indicator .....	2 - 8
UP key .....	2 - 3
Upper Level (COEF key) .....	4 - 22

## [ V ]

V display .....	2 - 8
V SOURCE terminal .....	2 - 5
Various Messages .....	3 - 4
VOL display .....	2 - 8
Voltage Applying Current Measurement .....	3 - 17
VSIM .....	3 - 17
VSRM .....	3 - 22

## [ Z ]

Zero Cancel (CAL key) .....	4 - 17
-----------------------------	--------

[  $\Omega$  ]

$\Omega$ display .....	2 - 8
------------------------	-------

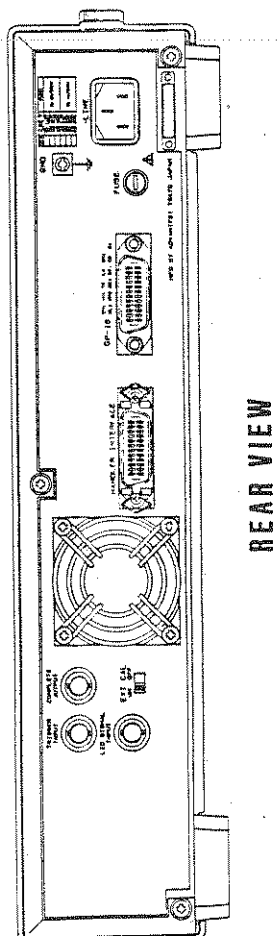
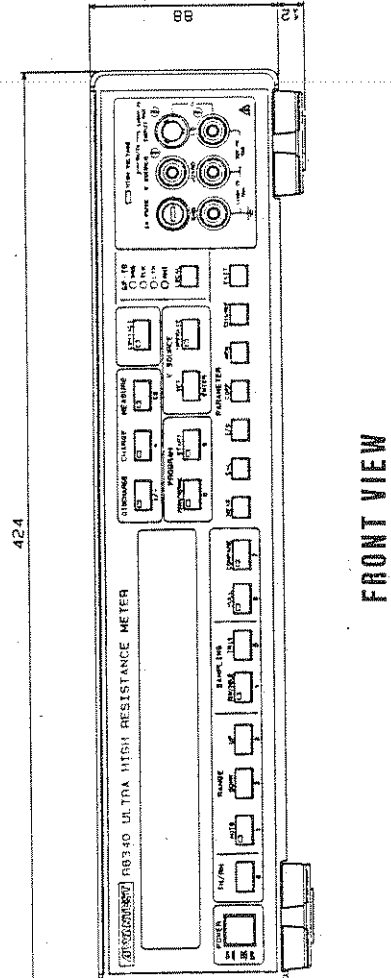
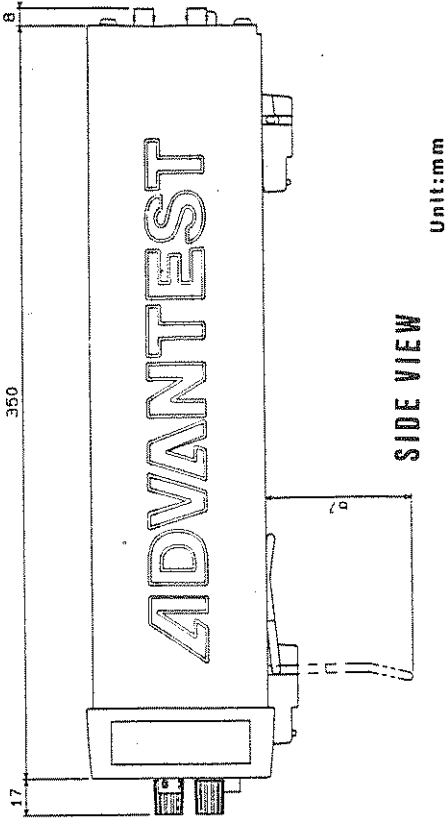

R8340  
EXTERNAL VIEW



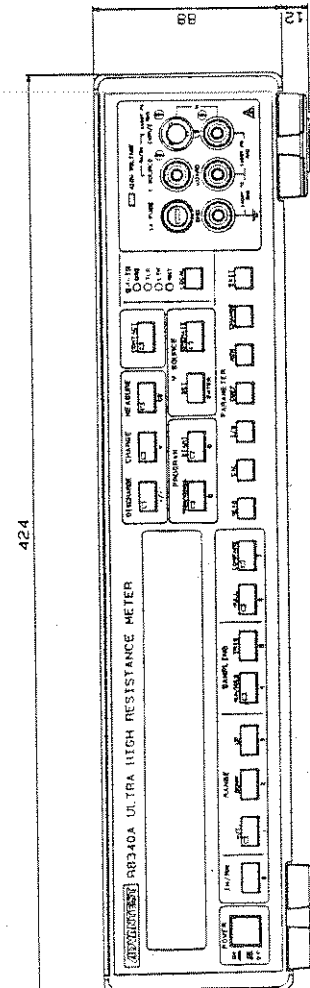

FRONT VIEW

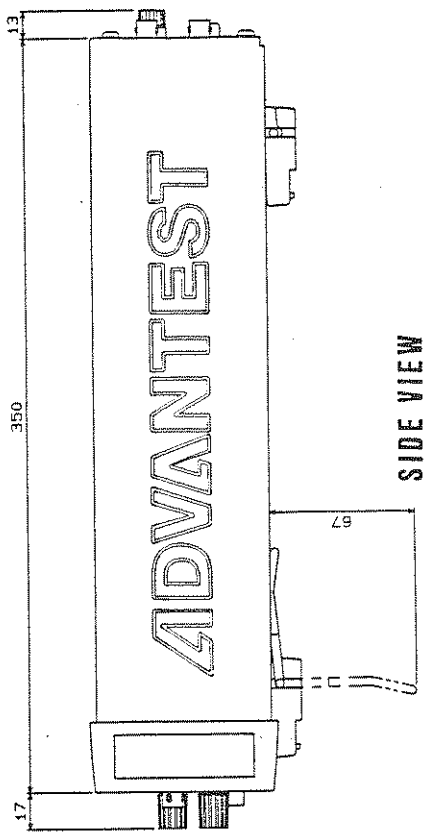

SIDE VIEW

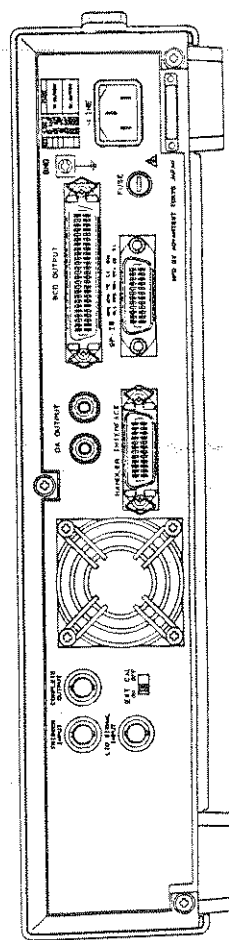

REAR VIEW

R8340A  
EXTERNAL VIEW