

N5511A Phase Noise Test System (PNTS)

With over 50 years of low phase noise, RF design, and measurement experience, Keysight solutions provide excellent measurement integrity, repeatability, and accuracy.



Table of Contents

N5511A PNTS Overview.....	3
N5511A PNTS Frequency Options	5
Keysight N5511A PNTS Theory of Operation.....	6
Most Flexible Measurement Solution.....	15
Easiest Integration into the Production ATE Environment.....	19
Measurement Expertise and Leadership	21
Keysight N5511A Solution Configuration.....	22
Keysight N5511A Specifications	26
Keysight N5511A Specification Summary	27
Keysight N5511A Specification Summary	29
Keysight N5511A AM Performance Summary.....	30

N5511A PNTS Overview

The Keysight Technologies, Inc. N5511A Phase Noise Test System (PNTS) is a replacement for the “gold-standard” Keysight E5500 phase noise measurement system. PNTS is the foundation of test systems that can measure phase noise down to kT (-177 dBm/Hz at room temperature). This thermal phase noise floor is the theoretical limit for any measurement. Therefore, the PNTS can measure at the limits of physics.

Phase noise is unwanted phase modulation noise that emerges from nearly all radio frequency (RF) and microwave devices including oscillators, mixers, frequency dividers, frequency multipliers and amplifiers. PNTS is designed for phase noise “power users” whose needs are consistently unmet by existing commercial phase noise test instrumentation such as “one-box” integrated test solutions. These individuals are typically phase noise experts that would like to fully characterize the phase noise (as well as AM noise and baseband noise) emerging from their radio frequency and microwave devices. Power users, including professionals responsible for developing high-performance aerospace and defense applications as well as characterizing cutting-edge devices for 5G and other wireless communication systems, need to perpetually validate and improve the phase noise performance of their designs.

Frequency range

- RF input frequency range: 50 kHz to 40 GHz using internal phase detectors
- Use of external phase detectors allows measurements of millimeter-wave signals to beyond 100 GHz
- Wide carrier offset range capability, from 0.01 Hz to 160 MHz internally (more than ten decades)

Noise measurement functions

- Absolute and residual phase noise using the phase detector (quadrature) method in both single-channel and two-channel configurations. Two-channels enables use of cross-spectral averaging (cross-correlation) for improving sensitivity down to “kT,” the thermal phase noise floor (-177 dBm/Hz)
- Measurement of one-port devices (VCO’s, DRO’s, crystal oscillators, synthesizers, etc.) and two-port devices (amplifiers, frequency converters, frequency dividers, etc.), plus CW, pulsed and spurious signals
- Noise floor (sensitivity) better than -200 dBc/Hz (with +23 dBm and higher input RF signal, using cross-correlation)
- AM noise on RF carriers from 50 kHz to 40 GHz
- Baseband noise measurement from 0.01 Hz to 160 MHz
- Pulsed RF measurements using built-in internal or customer-supplied external PRF filters

Additional capabilities and benefits

- Designed for phase noise “Power Users” whose needs are consistently unmet by existing commercial phase noise test instrumentation
- Multi-segment, fast real-time hardware cross-correlation using a Field Programmable Gate Array (FPGA)
- Replacement for Keysight E5505A with a familiar user interface that is fully SCPI backwards compatible
- Use of any frequency-tunable source as an external reference which can enable improved sensitivity for single-channel measurements and dramatically reduced cross-correlation time for dual-channel measurements
- Flexible configurations are possible for a variety of phase noise measurement techniques, including PLL/reference source, residual and FM discriminator methods
- “Future Proof” with PXIe: add additional pre-qualified modules to complete your test system (e.g. network analyzers, etc.)
- Open architecture combines standard instruments, phase noise components, and PC software in a flexible manner, allowing reuse of instrumentation assets (proprietary closed architectures are less flexible because the embedded reference sources and analyzers can limit phase noise measurement performance)
- N5510A software enables many standalone instruments to work together within a system
- Access to external power splitter gives user ability to add external attenuators, amplifiers, and other test setup accessories independently to each channel and suppress any additive noise from these devices via the cross-correlation process

N5511A PNTS Frequency Options

Option	Carrier Frequency Ranges	Offset Frequency Ranges
503	50 kHz to 3 GHz	0.01 Hz to 160 MHz
526	50 kHz to 26.5 GHz	0.01 Hz to 160 MHz
540	50 kHz to 40 GHz	0.01 Hz to 160 MHz

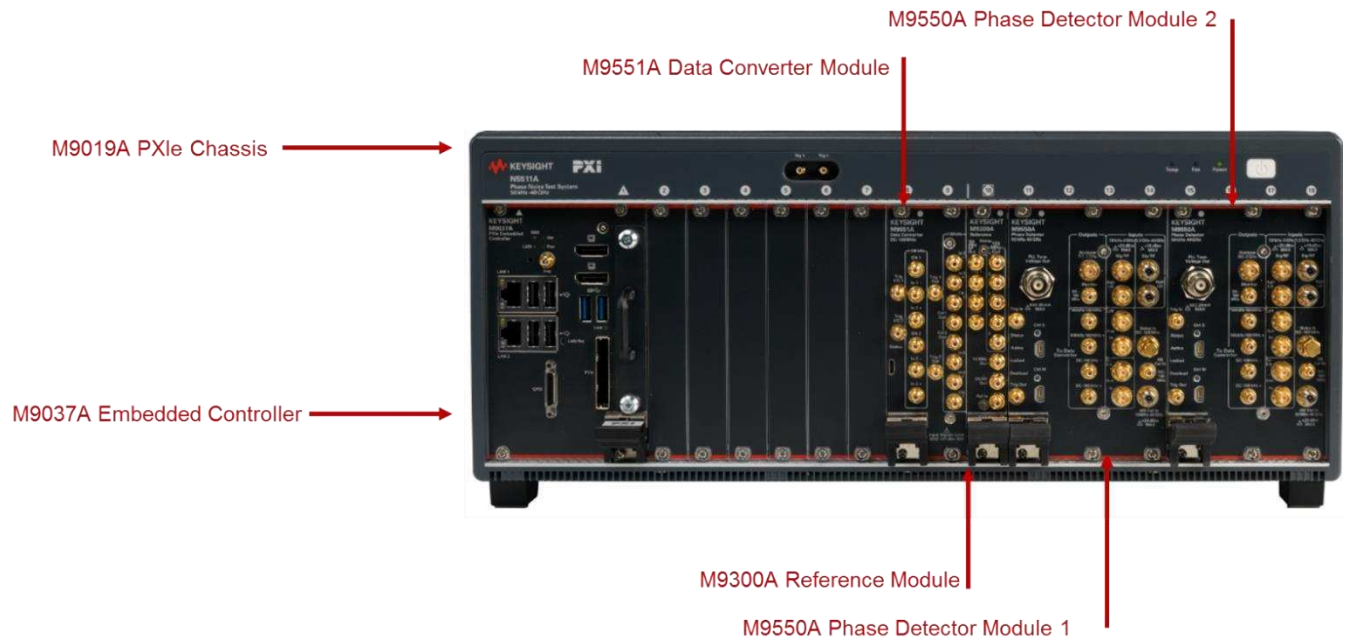

Figure 1: The PXI modules comprising the N5511A PNTS

Keysight N5511A PNTS Theory of Operation

Phase Detector Technique

The “phase detector with PLL and reference source” technique is the most general-purpose and sensitive measurement approach available for measuring the single sideband (SSB) phase noise characteristic of oscillators (absolute phase noise). This technique removes the carrier and demodulates the phase noise sidebands of the device-under-test (DUT) oscillator. The resulting baseband signal is then digitized and converted into the frequency domain using a Fast-Fourier Transform (FFT) by dedicated baseband analysis hardware. By using the phase detector technique, and thus removing the carrier, one can remove SNR-related limitations of devices in the measurement receiver such as amplifiers-and ADCs. Carrier removal can be thought of as raising the ceiling on the ADC full-scale or receiver preamp compression level. As a result, it is possible to optimize system sensitivity by significantly amplifying the detected small-signal baseband phase noise using high-gain baseband amplifiers with low noise figure. This can provide a large improvement in sensitivity compared to other phase noise measurement methods which down-convert the RF carrier to an IF signal and demodulate the phase noise using I-Q demodulation.

With the reference source and the DUT in steady-state quadrature, the phase detector generates a baseband signal proportional to the phase difference of the two sources. When the phase noise characteristics of the reference source signal are much less than the phase noise characteristics of the DUT signal, the resulting baseband noise signal is effectively that of the DUT.

A narrow-band phase-lock-loop (PLL) maintains the two-phase detector input signals in quadrature and allows the reference source to track DUT frequency drift for drift rates within the loop bandwidth. Phase noise fluctuations within the loop bandwidth are suppressed by the operation of the phase-lock-loop. This suppression effect can be independently measured, and the phase noise data corrected automatically by the measurement software. Phase noise fluctuations outside of the phase-lock-loop bandwidth are unaffected.

In a single-channel absolute measurement, there are three contributors to the overall phase noise at the output of the measurement system (labeled **FFT** in the figure below). The phase noise of the RF or microwave reference source ($\phi(t)_{ref}$) usually dominates the effective noise floor of this phase noise measurement (also known as sensitivity). The noise contribution of the phase detector module (NF_{ch}) inside the phase noise measurement system (also known as the system noise floor) is typically much lower than either the DUT ($\phi(t)_{dut}$) or reference source and therefore does not usually factor into the overall measurement noise floor in an absolute phase noise measurement.

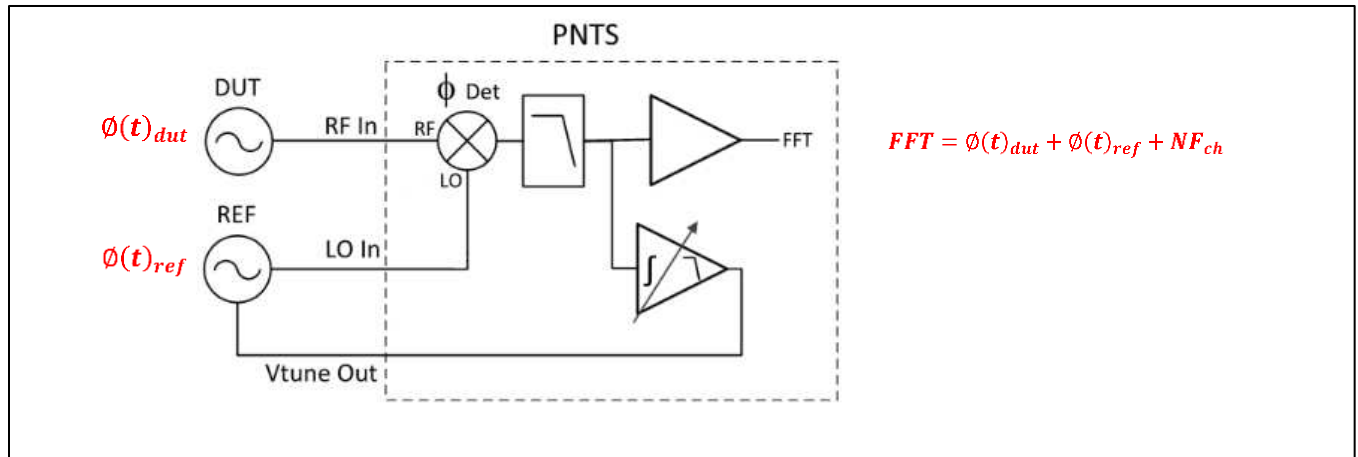

Figure 2. Simplified single-channel absolute phase noise measurement diagram showing three sources of total measured phase noise at the output of the system: $\phi(t)_{dut}$, $\phi(t)_{ref}$ and NF_{ch}

Dual-channel measurements with cross-spectral averaging (cross-correlation)

One of the main advantages of the N511A Phase Noise Test System (PNTS) is the dual-channel cross-spectral averaging (cross-correlation) capability. In a dual-channel cross-correlation configuration, the phase noise of the RF or microwave reference no longer limits the effective noise floor of the absolute phase noise measurement. Even the internal measurement system noise generated within the phase detector module is suppressed via the cross-correlation process. By suppressing both reference noise and measurement system noise, cross-correlation enables a sensitivity down to kT (-177 dBm/Hz at room temperature).

As we can see from the figure 3, the cross-correlation technique combines two duplicate and complete single-channel phase detectors with reference source/PLL systems, performing cross-correlation operations between the outputs of each channel.

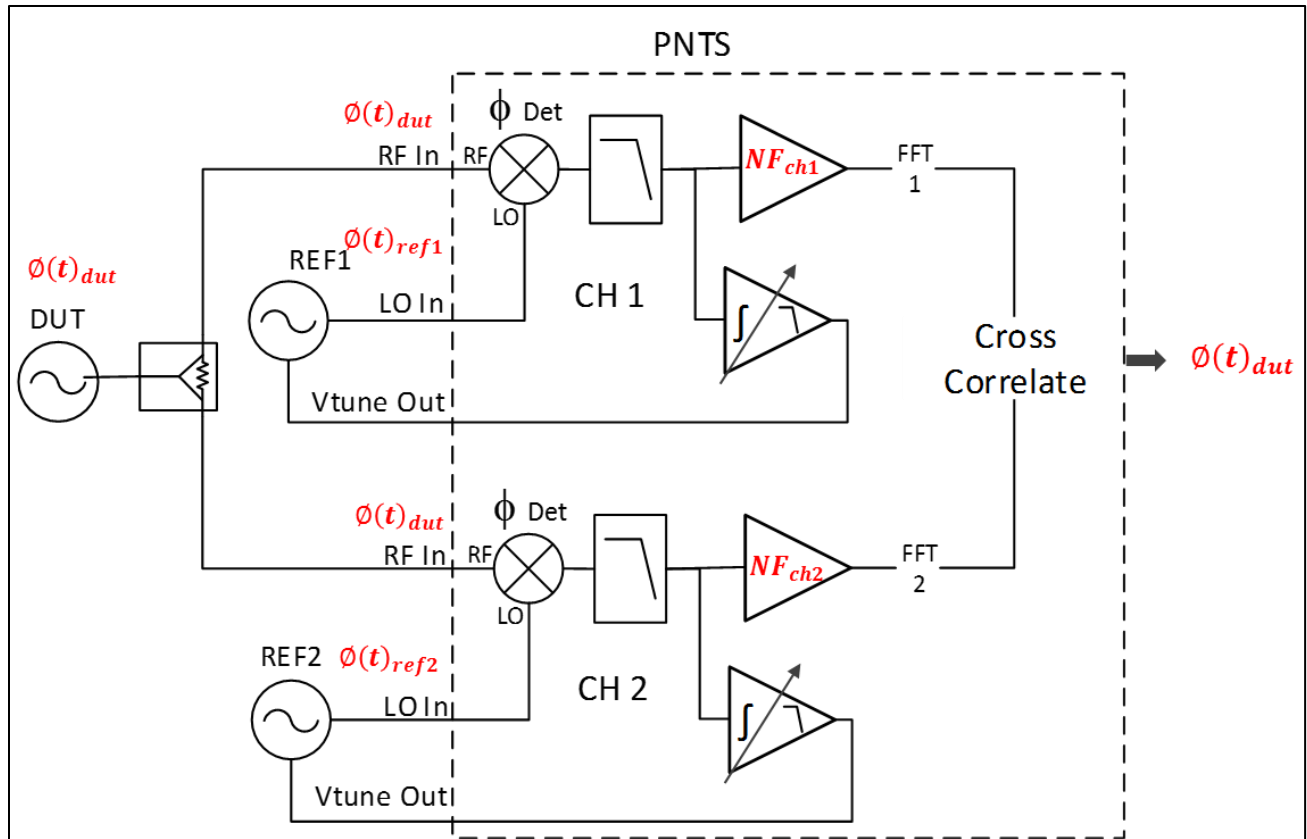

Figure 3. Simplified dual-channel absolute phase noise measurement diagram showing only one source of total measured phase noise at the output of the system after cross-correlation: $\phi(t)_{dut}$

A power splitter splits the DUT signal (with phase noise $\phi(t)_{dut}$) into two channels, and each signal goes into the RF port of two separate (and thus independent) phase detector modules. Each module contains double-balanced mixers used as phase detectors. Because the post-splitter DUT signal is identical in both paths, both channels will receive totally correlated (identical) phase noise from the DUT ($\phi(t)_{dut}$). Two separate and completely independent reference sources REF1 and REF2 (with uncorrelated phase noise $\phi(t)_{ref1}$ and $\phi(t)_{ref2}$ respectively) go into the LO port of each phase detector. There are also two separate PLL circuits that maintain each reference source in quadrature with the DUT. Finally, there are two separate baseband signal processing blocks (with uncorrelated noise NF_{ch1} and NF_{ch2}), one for each channel.

The duplication of various components in the reference source/PLL/baseband processing block diagram allows the system to suppress uncorrelated noise (and keep only the correlated DUT noise $\phi(t)_{dut}$) via the cross-correlation process. We can see how this works by looking at the output of each channel:

Channel 1:

$$FFT_{ch1} = \phi(t)_{dut} + \phi(t)_{ref1} + NF_{ch1}$$

Channel 2:

$$FFT_{ch2} = \phi(t)_{dut} + \phi(t)_{ref2} + NF_{ch2}$$

We can think of the cross-correlation (also known by the shorthand “Xcorr”) process as comparing the output phase noise from each channel and suppressing the phase noise that is different (uncorrelated) in each channel and keeping the phase noise that is the same (correlated). After suppressing the terms that are different and keeping the terms that are the same, we are left with only the phase noise of the DUT:

$$\mathbf{Xcorr}(FFT_{ch1}, FFT_{ch2}) = \phi(t)_{dut}$$

With cross-correlation, the PNTS can suppress any noise that doesn't originate from the DUT and achieve an ultimate sensitivity approaching the limits of physics (thermal phase noise floor at -177 dBm/Hz). The only tradeoff: the greater the amount of uncorrelated noise present in the system (generally from low-performance reference sources with a lot internal phase noise), the more **time** it takes for the system to suppress it because it is fundamentally a mathematical/computational process. However, the user can take advantage of the unique and flexible architecture of the N5511A PNTS and minimize this time penalty to the greatest extent possible.

The first architectural feature of the PNTS that minimizes the cross-correlation time penalty is Field Programmable Gate Array (FPGA) processing of all FFTs and cross-correlations in real-time. This means that cross-spectral averaging is performed in FPGA hardware rather than in software on a microprocessor (CPU) and is therefore much faster. The computations are performed on all offset frequency segments of the trace in parallel (multi-segment parallel processing) and displayed in real time.

The second architectural feature that PNTS has that minimizes the cross-correlation time penalty is the ability to use any electronically frequency tunable reference. This allows the use of the best available signal generators today (or even use copies of the DUT as references) and get better performance in the future as newer and higher-performance signal generators come to market. This reduces the cross-correlation time penalty because lower phase noise (better performance) references add less uncorrelated noise to the measurement and thus require fewer correlations (and less time) to suppress this lower uncorrelated reference noise and allow the user to observe their device's true phase noise.

User devices often have phase noise performance that is superior to that of the best available signal generators (or internal references within some phase noise systems). The following three measurement screenshots show examples of the use of copies of the user DUT as references (REF1 and REF2 in the above PNTS block diagram) when measuring the DUT (therefore there are three copies of the DUT in this PNTS system configuration). If the DUT is used as a reference, the PNTS measurement sensitivity starts at similar a level to the DUT phase noise performance level. This means the cross-correlation process starts out at this sensitivity and this system sensitivity gets better as cross-correlations are processed. We can quantify this by saying that for a 10 times increase in the number of correlations, there is a 5 dB reduction in uncorrelated noise (and 5 dB improvement in PNTS system sensitivity). Because more correlations means more time, we would like the cross-correlation process to start out at as low of a phase noise sensitivity as possible. N5511A's parallel multi-segment FPGA cross-correlation engine allows it to process millions of cross-correlations at the furthest-out offsets in the same time that it processes one cross-correlation at the closest-in offsets. This means if the user starts out with reference performance equal to or better than their DUT (as in the case of using copies of their DUT as references),

they will add to test margin (at further out offsets) with the cross-correlation process in the time it takes to acquire the first data for the closest-in offset (and thus paying no cross-correlation time-penalty).

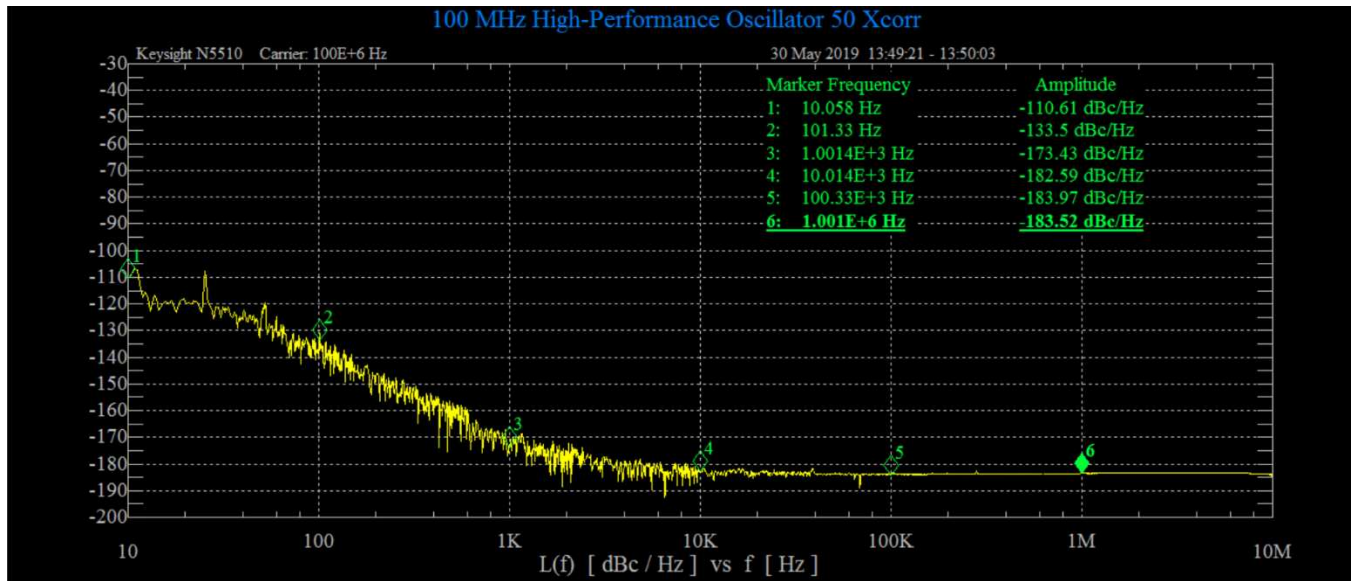

Example 1: Using a 100 MHz high-performance DUT as both REF1 and REF2 significantly reduces the number of cross-correlations -resulting in a dramatic reduction in measurement time (~40 seconds to get to a -184 dBc/Hz correlated device phase noise floor)

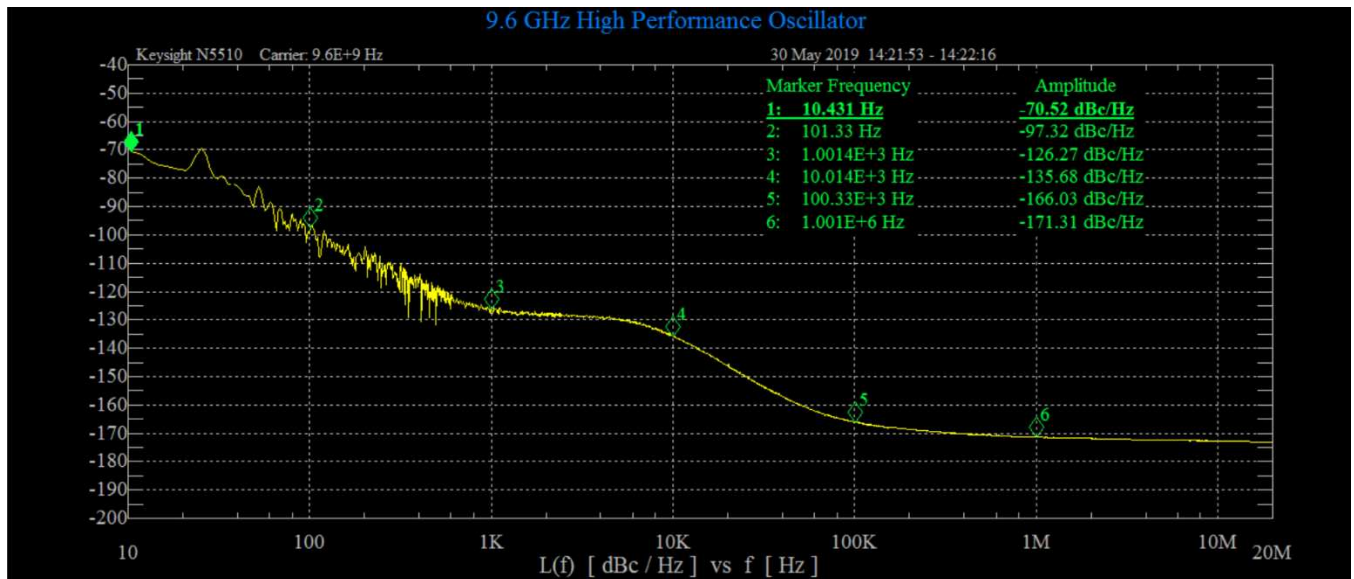

Example 2: Using a 9.6 GHz high-performance DUT as both REF1 and REF2 significantly reduces the number of cross-correlations -resulting in a dramatic reduction in measurement time (~25 seconds to get to a -171 dBc/Hz correlated device phase noise floor)



Example 3: Using a 10 MHz high-performance DUT as both REF1 and REF2 significantly reduces the number of cross-correlations -resulting in a dramatic reduction in measurement time (~20 minutes to get to a -60 dBc/Hz correlated device phase noise at a .01 Hz offset)

Cross-Correlated PNTS System Noise Floor for Sensitivity down to kT (-177 dBm/Hz)

Theoretically, kT (thermal noise power density) is a physical floor limiting the achievable phase noise performance of any DUT (as well as the measurement system) and is defined by an *absolute* signal level (-174 dBm/Hz at room temperature). Some refer to this analogously to kTB noise; however, kTB is a *total* power and not a power *density* because it takes bandwidth into account.

When added to a carrier signal, thermal noise (kT) manifests as modulation of the carrier with equal amounts of amplitude modulation (AM) and phase modulation (PM) due to equipartition of energy. When measuring phase noise, we are only concerned with the phase modulation noise (PM) component of thermal noise. Therefore, if we remove the AM component of thermal noise and include only the PM component, we end up with 3 dB less (half of the power) remaining, or -177 dBm/Hz. This is our thermal *phase* noise floor (or minimum achievable sensitivity in a phase noise measurement as dictated by physics).

Beyond a minimum *absolute* phase noise floor of kT (-177 dBm/Hz), we also need to understand how carrier power can affect the theoretical limits to both DUT and measurement system phase noise performance. In a phase noise measurement, the signal level (carrier power) is measured *relative* to the kT noise floor and will directly dictate the best achievable phase noise performance any device can achieve within the bounds of physics at a given carrier power level (maximum possible dynamic range). This means a phase noise measurement is actually a noise-to-carrier ratio and it is reported by the measurement system as a noise power density *relative* to a carrier power level (in units of dBc/Hz). For example, as seen below, with a +20 dBm carrier signal, the theoretical best phase noise performance any device can achieve is -197 dBc/Hz (various carrier powers vs. theoretical maximum achievable phase noise is shown in the table below).

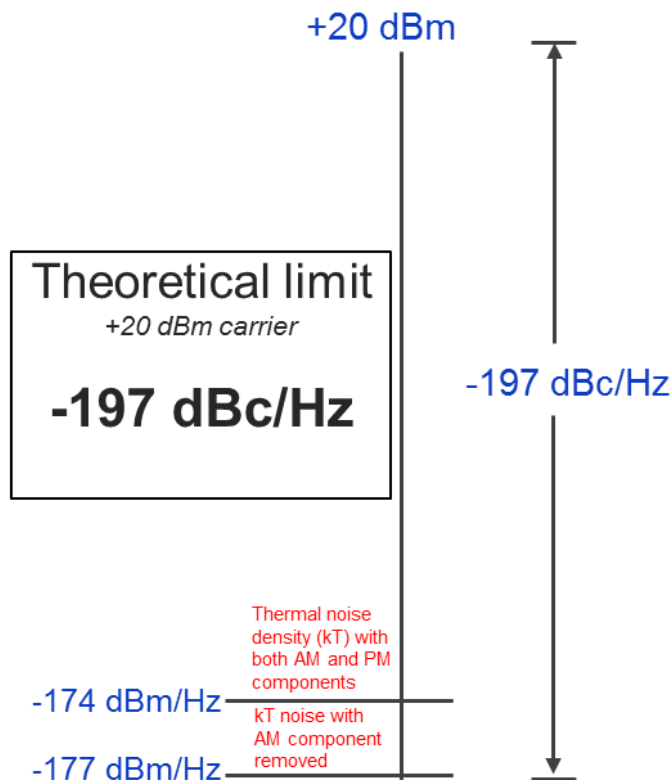

The theoretical limit to phase noise performance that any device can achieve with a +20 dBm input signal is -197 dBc/Hz

P_{carrier} (dBm)	$\mathcal{L}(f)$ dBc/Hz
+30	-207
+20	-197
+10	-187
0	-177
-10	-167
-20	-157

The theoretical (kT) limit to phase noise ($\mathcal{L}(f)$) performance that any device can achieve with various input carrier power levels (P_{carrier})

Now that we have established the theoretical maximum phase noise performance any DUT or measurement system can achieve, let's explore practical limits to measurement system noise floor (also known as sensitivity and residual noise floor). The single-channel configuration of the N5511A PNTS is limited by the 1/f noise and noise figure of the phase detector and baseband signal processing blocks as we saw earlier represented by added noise NF_{ch} . In the plot of the PNTS phase noise floor below, it is denoted by the dashed tan line. In this single-channel configuration, this is the practical limit to PNTS system performance and the system will not be able to measure any device below the tan line. This PNTS noise floor in the single-channel configuration is very similar to the noise floor of the N5500A Test Set in the E5505A system. In this case, we have used an input stimulus carrier power of +20 dBm and so the kT theoretical limit that any DUT or test system can achieve would be -197 dBc/Hz. At the far-out offsets, the dashed tan line (single-channel PNTS noise floor) is only about -183 dBc/Hz).

In the dual-channel configuration (with two phase detector modules), however, PNTS can suppress the system noise in the phase detector modules with cross-spectral averaging (cross-correlation) and approach a sensitivity of kT (-177 dBm/Hz) which allows measuring the phase noise of almost any DUT. This is made possible because the phase detector modules are physically independent units and thus produce totally uncorrelated phase noise NF_{ch1} and NF_{ch2} . This is shown in the same figure below and is represented by the solid tan line. In this example, there is 1 cross-correlation performed at 1 Hz offset with a 128-point FFT size. In 21 seconds, PNTS is able to achieve kT sensitivity (-197 dBc/Hz with this +20 dBm input stimulus) at 10 kHz offsets and above. If more cross-correlations were performed, PNTS would suppress the uncorrelated system phase noise at closer-in offsets by 5 dB for every 10 times increase in correlations. With enough correlations, the system would highly suppress the uncorrelated system noise and produce a noise floor (sensitivity) with uniform phase noise density asymptotically approaching kT (-197 dBc/Hz for +20 dBm input) at all offsets.

PNTS Phase Noise Floor Single (no Xcorr) and Dual Channel (with Xcorr)

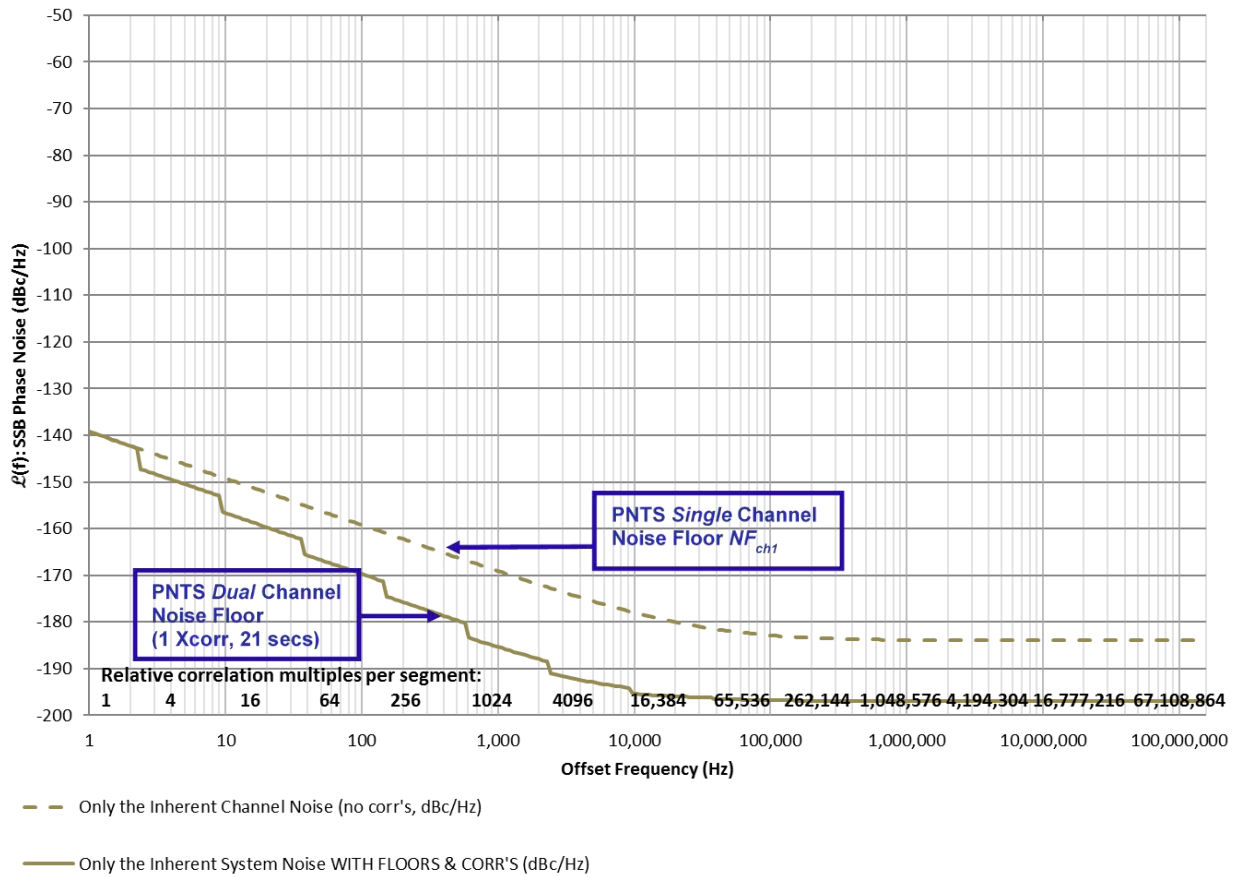

PNTS residual (system) noise floor (+20 dBm input signal, $kT = -197$ dBc/Hz) for both single (no cross-correlation, dashed tan line) and dual-channel (with cross-correlation, solid tan line) with 1 cross-correlation at 1 Hz offset in 21 seconds with a 128-point FFT size

Most Flexible Measurement Solution

The N5511A has been tailored to meet the extensive needs of engineers, allowing for the most flexible configurations to enable the user to make superior measurements on a wide range of devices. The modular instrument architecture takes advantage of standalone instrumentation for superior frequency offset range, broadest capability, best sensitivity, and excellent overall value for phase noise measurements. The N5511A low internal noise floor (which can itself be suppressed with cross-correlation down to kT or -177 dBm/Hz at room temperature) and measurement flexibility let you measure a wide variety of devices with one system.

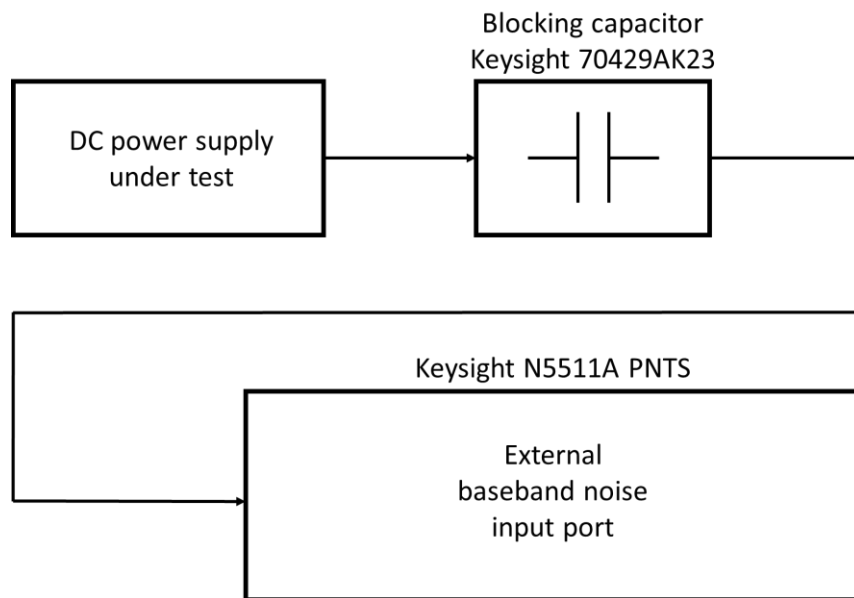

Measuring noise using the external baseband noise input port

Ability to test a wide range of devices

The N5511A measures the absolute, single sideband phase noise, the absolute AM noise, and the low-level spurious signals of a wide range of one-port devices with either CW or pulsed carrier signals:

- VCOs, DROs, and fixed-frequency oscillators
- Crystal oscillators and clocks
- High frequency synthesizers, CW and pulsed carrier
- Low noise DC power supplies

Measure AM noise directly

The N5511A PNTS can directly measure the AM noise of RF and microwave devices. The internal AM detector and DC blocking filter provided within Keysight's N5511A measures AM noise on carriers from 50 kHz to 40 GHz. AM noise of millimeter frequency devices can be measured with an external AM detector.

Additive noise measurements on two-port devices

The N5511A also measures the residual (or *additive*) phase noise, AM noise, and low-level spurious signals of two-port devices with either CW or pulsed carrier signals:

- High power amplifiers
- Frequency dividers
- Frequency multipliers
- Mixers, combiners, etc.
- Entire RF or microwave subsystems

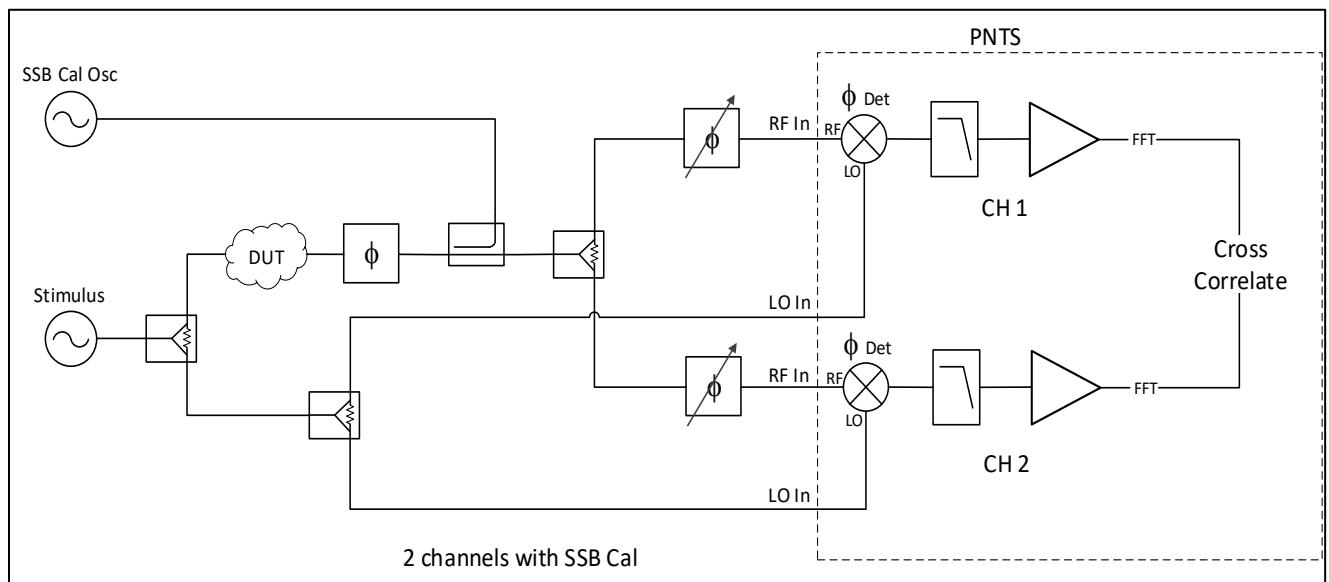

Residual noise measurement of a two-port device using the single-sided spur calibration method

The N5511A PNTS is the ideal residual and additive phase noise measurement system due to its inherent architectural advantages already discussed. Because the phase detector method of measuring phase noise cancels the carrier, the system has an initial dynamic range that is only limited by the phase detector module's extremely low internal noise. This internal noise is then quickly suppressed with FPGA-based cross-spectral averaging (cross-correlation), allowing the system to approach a cross-correlated noise floor down to kT (-177 dBm/Hz). This sensitivity is at the limit of what physics allows and will give any low phase noise two-port DUT plenty of margin for accurate, precise and extremely fast measurements.

Pulsed Carrier Noise Measurements

The N5511A also measures pulsed carrier phase noise and AM noise. It can perform residual measurements on pulsed RF carriers as well as absolute measurements on pulsed carriers.

The phase detector modules in the N5511A come equipped with multiple internal PRF (pulse repetition frequency) filters; these are just low pass filters (LPFs) because all analog and digital signal processing

performed after the phase detectors in PNTS is performed at baseband. However, if there is a measurement requirement for LPFs with different cutoff frequencies than the ones provided, N5511A offers the flexibility of adding user-supplied external filters.

Superior frequency offset range

The N5511A PNTS comes standard with the capability to directly measure from 0.01 Hz to 160 MHz of offset range from the carrier (for both phase and amplitude noise). This wide offset range provides engineers with more information about the test device's performance close-to-carrier and far-from carrier. This capability is enabled by the M9551A data converter module inside PNTS. The M9551A data converter module provides complete coverage of the 0.01 Hz to 160 MHz offset range by utilizing four on-board ADCs. There are two ADCs per channel, with each channel having one low-band 24-bit 12.5 Msample/s delta-sigma ADC for offsets from 0.01 Hz to 156 kHz and one high-band 14-bit 400 Msample/s ADC for offsets from 156 kHz to 160 MHz. All the ADCs connect to a large FPGA for fast FFT processing. For offsets beyond this range, the user can add an external signal analyzer to the PNTS system. If a two-channel analyzer with cross-spectral averaging is utilized, cross-correlated phase noise measurements are possible.

Handles carrier frequencies to 40 GHz and beyond

The M9550A Phase Detector module can internally operate at carrier frequencies between 50 kHz and 40 GHz (refer to Frequency Options on page 3). Measurements on carriers at frequencies above 40 GHz can be easily performed using external double-balanced mixers with a 0 Hz IF capability with 0V DC output at phase quadrature. This allows the mixer to operate as a phase detector. The phase detector IF is connected to the fully-calibrated baseband noise input port (with 0.01 Hz to 160 MHz analysis capability) on the M9550A phase detector module. Connecting two physically separate phase detectors (mixers) to each PNTS channel allows any conversion loss or degradation of phase noise from each mixer to be suppressed by the cross-correlation process. In addition to the internal phase detectors and baseband noise input, the M9550A Phase Detector Module also includes an internal AM detector, LNAs for up to 56 dB of gain, PRF filters, and the PLL circuitry to set and maintain quadrature between the DUT and reference oscillator in an absolute measurement. All of these functions within the phase detector module operate across the full frequency range of the system.

User access to two-channel power splitter and cross-correlation allows arbitrary attenuation and gain to be added without degrading phase noise

The system allows access to both channels due to the use of an external power splitter, allowing the user to add arbitrary gain and/or attenuation for signal conditioning (i.e. amplifiers and attenuators) on each channel independently after the splitter. This enables the N5511A PNTS to suppress any additive noise from these test accessories by employing cross-correlation. In the case of added attenuation, the cross-correlation process enables the system to recover the SNR available at the input of the two-channel splitter (no degradation of the noise floor). Similarly, any additive phase noise from amplifiers added to each PNTS channel is similarly suppressed using the cross-correlation process, allowing the user to see the true performance of their device under test on the system display.

Wide choice of reference sources

The N5511A offers a wide choice of low noise reference sources because this system component is critical to the overall phase noise measurement performance in an absolute measurement. One reference source might be needed to measure the best close-to-carrier phase noise and another reference could easily be used for the best far from carrier phase noise measurements. Unlike proprietary architectures that limit your choice to one or two captive reference sources, the N5511A supports numerous reference sources to fit your application. Use of standalone instruments often provides the best value and are easily reused on your bench or in your ATE systems. In addition to standalone instruments, the N5511A can use almost any voltage-tunable source as a reference. Each M9550A phase detector module provides the “PLL Tune Voltage Out” using a BNC connector (denoted “Vtune Out” herein) to allow the internal PLL circuitry to independently tune and independently phase lock each reference oscillator in quadrature with the DUT oscillator. The reference sources can even be copies of the DUT. If the DUT has noise performance that is much better than any commercially available signal generator or reference source, the N5511A can even use copies of the DUT to start the cross-correlation process near the correlated floor of the device and simply add to test margin with more correlations, potentially decreasing the measurement time by many orders of magnitude.

Remember, the N5511A has an internal noise floor well below the noise of most reference sources and therefore does not require special phase detectors to lower the noise floor further. One reason for this is the use of very low noise LNAs in the phase detector modules and a PXIe chassis that is significantly modified for low noise performance and spur reduction. To push the PNTS noise floor down to the edge of what is physically realizable in the dual-channel configurations of PNTS, the internal noise floor can be suppressed using cross-correlation (because of two physically separate phase detector modules that produce totally uncorrelated noise) to achieve sensitivity down to kT (-177 dBm/Hz).

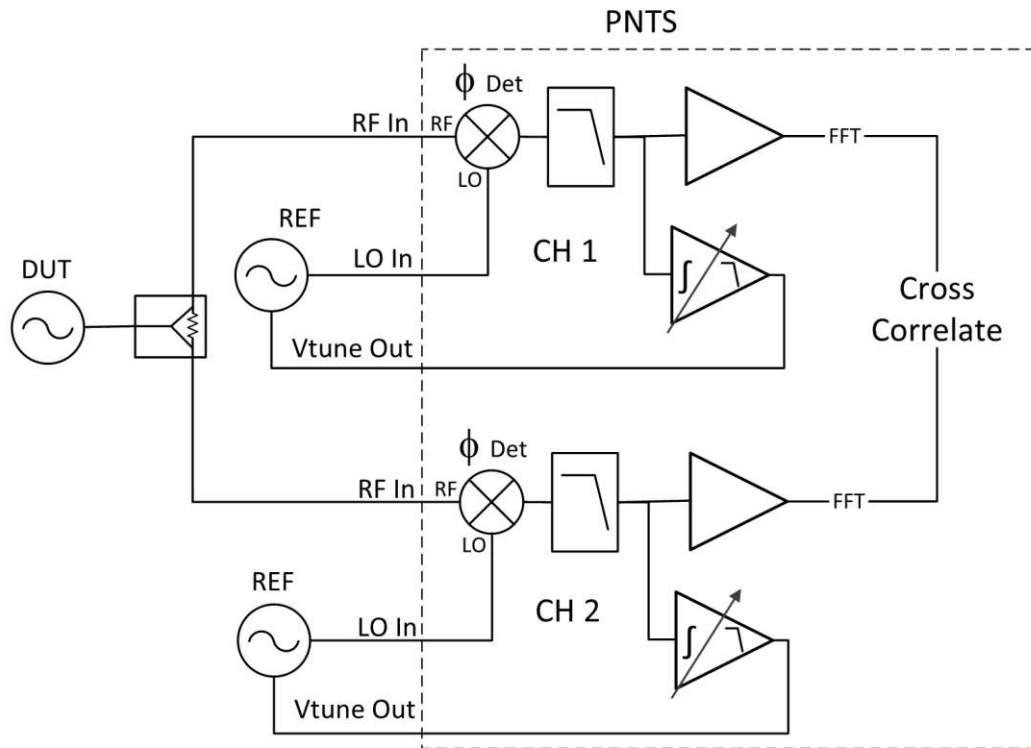

Vtune Out line connecting PNTS to each REF for electronic frequency tuning (for PLL to maintain quadrature between the DUT and each REF independently)

Easiest Integration into the Production ATE Environment

The N5511A PNTS is tailored to meet the demanding needs of a production ATE environment. With test times of less than 3 seconds (1 kHz to 100 kHz offset range) and less than 30 seconds (10 Hz to 1 MHz offset range) achievable after user calibration, the N5511A PNTS meets the high throughput and needs for today's higher volume devices.

Key features for ATE are:

- Quick and easy integration into existing ATE systems using standard instruments and SCPI programming
- “Just-enough” measurement performance because of the configuration flexibility of N5511A
- Lowest overall cost of measurement by using standalone instruments likely to be included in your ATE system

A configuration for an ATE application would simply consist of the N5511A PNTS as a core ATE system component and would be expanded based upon application-specific requirements. All configurations of the N5511A system include at least one M9550A phase detector module which provides all the phase detectors, amplifiers, filters, switches, and attenuators necessary to measure phase noise over the IF, RF, and microwave frequency ranges directly. The M9551A data converter module digitizes the baseband noise signal from the phase detector module and also does all FFT and cross-correlation processing via the onboard fast FPGA. The measurement software provides all the operator interaction, measurement

coordination, calibration, data signal processing, and data results. The remote “standard commands for programmable instruments” (SCPI) programming interface client provides quick and easy integration into new and existing production test environments.

Quick and easy integration into your ATE system

With a completely defined, industry standard SCPI programming interface client, the N5511A can be quickly and easily integrated into your specific ATE computing environment. If you choose to configure an N5511A solution to be controlled from a separate computer, initiate a measurement over LAN or GPIB using the standard, remote, SCPI command language. Full measurement system control, including capturing measurement data, is included. If your production ATE computing environment runs under Microsoft Windows, a separate computer is not necessary. Simply initiate a measurement using the multitasking capability of Windows and the remote SCPI interface to communicate with the N5510A measurement software running concurrently on your ATE computer. Data is available in two ASCII formats: a spreadsheet format and an XY graph format. Other data translators can be specified and provided.

Software summary

- Modular, object-oriented, client/server architecture
- Windows-compliant graphical user interface and operating system
- Industry standard SCPI programming language
- Standard ASCII data formats

A simple SCPI programming example:

```
SENSe:NOISe:MEAStype ABSolute
CARRier:FREQuency:FIXed 10 MHz
REFerence:FREQuency:FIXed 10 MHz
SENSe:DETector:FREQuency 10 MHz
SENSe:DETector LFRequenc
SENSe:RANGe:OFFSet 10 Hz, 10 MHz
SENSe:RANGe:SEGTable:MEASurement:QUALity FAST
DISPlay GRAPh:TRANSform SSBNoise
INITiate:CALibrate
TTOTAL?
*WAI
*STB?
CALCulate:VIEW:XYDATA
CALCulate:DATA:HEADer: POINTs?
CALCulate:DATA?
```

Measurement Expertise and Leadership

The N5511A provides the kind of measurement integrity and leadership that you have come to expect from Keysight Technologies. The software design provides exceptional flexibility, measurement integrity, and low overall cost-of-measurement. The new dedicated hardware modules provide improved measurement range, proven reliability, and excellent repeatability.

Worldwide application services and hardware support

Keysight has a complete, worldwide support services structure in place, providing regional hardware calibration and repair and local application expertise.

Trained phase noise application engineers will provide on-site training. The training explains all operating modes of the N5511A, when each measurement technique is appropriate, and how to analyze the measured data. Additional application assistance focused on measuring your specific devices is also available. Support options include worldwide service and support, on-site training, applications assistance, access to N5511A system experts, and remote access to software updates and application information.

Keysight N5511A Solution Configuration

The N5511A PNTS can easily be configured to meet the needs of bench R&D or production ATE environments. The system features modular hardware including specific phase noise instruments, industry-standard instruments, and a Windows PC controller for maximum test throughput, current and future measurement flexibility, and asset reuse. These solutions can easily include specific RF and microwave reference sources, additional baseband analysis hardware, and computers for complete production phase noise measurement solutions.

Operating Characteristics	Description
Offset frequency range	0.01 Hz to 160 MHz
System noise response	-180 dBc/Hz typically (> 10 kHz offsets) for single channel configurations (cross-correlation can achieve sensitivity approaching -177 dBm/Hz)
System spurious response	< -120 dBc typically
Phase detector input power	RF Detector (< 3 GHz carrier frequency) RF input = 0 to +23 dBm LO input = +15 to +23 dBm Microwave Detector (> 1.2 GHz carrier frequency) RF input = 0 to +15 dBm LO input = +7 to +15 dBm
External noise input port	0.01 Hz to 160 MHz
Measurement accuracy	±2 dB (< 1.0 MHz offsets) ±4 dB (< 160 MHz offsets)

Configuring a specific phase noise test system

Using your Keysight sales representative and applications/support engineer, we configure specific solutions to meet your bench or ATE application. The following hardware and software components are selected depending on your measurement requirements.

Keysight N5511A bench or ATE phase noise test system

This step-by-step process will help you configure your N5511A Phase Noise Test System. Tailor the performance to meet your requirements.

Included in the base product

Standard options and accessories come with the N5511A base model at no additional charge and do not need to be ordered. They include:

- N5510A application software with all software features included
- Low Noise Custom PXIe Chassis with embedded PC controller

- Microwave power splitter 10 GHz – 40 GHz (for CH2)
- 2.9 mm, 50 Ohm cable assembly, 6 inches (for CH2)
- One day of on-site startup assistance
- USB keyboard
- USB mouse

Step 1. Choose frequency range		
Description	Option Number	Additional Information
Frequency range from 50 kHz to 3 GHz	N5511A-503	Measurement offset from carrier from 0.01 Hz to 160 MHz Includes 1 GHz – 26.5 GHz power splitter
Frequency range from 50 kHz to 26.5 GHz	N5511A-526	Measurement offset from carrier from 0.01 Hz to 160 MHz Includes 1 GHz – 26.5 GHz power splitter
Frequency range from 50 kHz to 40 GHz	N5511A-540	Measurement offset from carrier from 0.01 Hz to 160 MHz Includes 10 GHz – 40 GHz power splitter

Step 2. Choose number of channels		
Description	Option Number	Additional Information
Single-channel	N5511A-CH1	
Dual-channel	N5511A-CH2	Enables dual-channel cross-correlation for sensitivity approaching kT (-177 dBm/Hz)

Step 3. Choose a low noise reference signal generator		
Description	Option Number	Additional Information
PSG analog/vector signal generator	E8257D/E8267D	Option UNY or HY2 recommended for best phase noise performance; UNT for DCFM reference tuning
PSG RF analog signal generator	E8663D	Option UNY or HY2 recommended for best phase noise performance; UNT for DCFM reference tuning
MXG X-Series RF analog/vector signal generator	N5181B/N5182B	Option UNY recommended for best phase noise performance; UNT for DCFM reference tuning
MXG X-Series microwave analog signal generator	N5183B	Option UNY recommended for best phase noise performance; UNT for DCFM reference tuning
EXG X-Series RF analog/vector signal generator	N5171B/N5172B	UNT for DCFM reference tuning
EXG X-Series microwave analog signal generator	N5173B	UNT for DCFM reference tuning

Step 4. Choose accessories

Description	Option Number	Additional Information
Rack mount kit	Y1215C	
Additional removable solid state drive, Win 10	N5511A-SS1	

Step 5. Choose calibration options

Description	Option Number	Additional Information
3-year calibration plan	R50C-011-3	Return to Keysight calibration plan
5-year calibration plan	R50C-011-5	Return to Keysight calibration plan
7-year calibration plan	R50C-011-7	Return to Keysight calibration plan
10-year calibration plan	R50C-011-10	Return to Keysight calibration plan

Step 6. Choose startup assistance service options

Description	Option Number	Additional Information
Remote scheduled productivity assistance. Select 1 to 999 hours.	PS-S10	
Startup assistance, daily	PS-S20	
Custom services	PS-SX10	

Step 7. Choose warranty options

Description	Option Number	Additional Information
Standard 1-year warranty	R-51B-001-C	Included in base model
Extend to 3-year warranty	R-51B-001-3C	
Extend to 5-year warranty	R-51B-001-5C	
Extend to 7-year warranty	R-51B-001-7C	
Extend to 10-year warranty	R-51B-001-10C	

Step 8. Choose KeysightCare options

Description	Option Number	Additional Information
KeysightCare Assured First Year Support	R55A-001-1	Included in base model
Extend KeysightCare Assured to 2 years	R55A-001-2	Includes repair coverage
Extend KeysightCare Assured to 3 years	R55A-001-3	Includes repair coverage
Extend KeysightCare Assured to 5 years	R55A-001-5	Includes repair coverage

Instrument software control

The base N5511A system automatically includes all instrument control software including the firmware and N5510A application software with all software features included by default.

Optional capabilities

- Extend offset range beyond 160 MHz
- Extend carrier frequency beyond 100 GHz
- Add remote SCPI programming client for ATE environments

Keysight N5511A Specifications

Determining overall solution performance

Measurement accuracy

Measurement of all noise and spurious present at the phase detector inputs and system contribution, provided the following conditions are met:

- Source return loss > 9.5 dB ($< 2:1$ VSWR)
- Source harmonic distortion < -20 dB (or square wave)
- Nonharmonic spurious < -26 dBc (except for PM close to carrier)
- Supported measurement configuration (PLL verification)
- ± 2 dB for < 1.0 MHz offsets
- ± 4 dB for < 100 MHz offsets
- ± 5 dB for < 160 MHz offsets

Overall phase noise measurement system sensitivity is a combination of noise contributions from the baseband test set (phase detector module) and the RF reference source used (for absolute measurements) and is normally dominated by the RF reference source.

Keysight N5511A Specification Summary

	Low frequency inputs (SMA) All Options	High frequency inputs (Type K) Option 526	High frequency inputs (Type K) Option 540	AM Noise input (SMA) All Options
Carrier frequency range	50 kHz to 3 GHz	1.2 GHz to 26.5 GHz	1.2 GHz to 40 GHz	50 kHz to 40 GHz
RF input power LO input power	0 dBm to +23 dBm +15 dBm to +23 dBm	0 dBm to +15 dBm +7 dBm to +15 dBm	0 dBm to +15 dBm +7 dBm to +15 dBm	0 dBm to +30 dBm N/A
Offset frequency range		Noise input port		
Offset frequency	Detector input frequency			
0.01 Hz to 20 kHz	50 kHz to 500 kHz	Frequency:	0.01 Hz to 160 MHz	
0.01 Hz to 200 kHz	500 kHz to 5 MHz	Amplitude:	1 volt peak max	
0.01 Hz to 2 MHz	5 MHz to 50 MHz	Input impedance:	50 Ω (typical), (DC coupled, RL > 9.5 dB (typical))	
0.01 Hz to 20 MHz	50 MHz to 500 MHz			
0.01 Hz to 160 MHz	500 MHz to 3 GHz or 26.5 GHz or 40 GHz (depending on frequency option)			
PLL tuning voltage output		Noise floor degradation		
Voltage range	± 10 volts, open circuit	Degrade system noise floor 1 dB for every dB reduction in R input levels less than:		
Current	20 mA, max	+15 dBm (low frequency input)		
Output impedance	50 Ω , typical	+5 dBm (high frequency input)		

PNTS Phase Noise Floor Single (no Xcorr) and Dual Channel (with Xcorr)

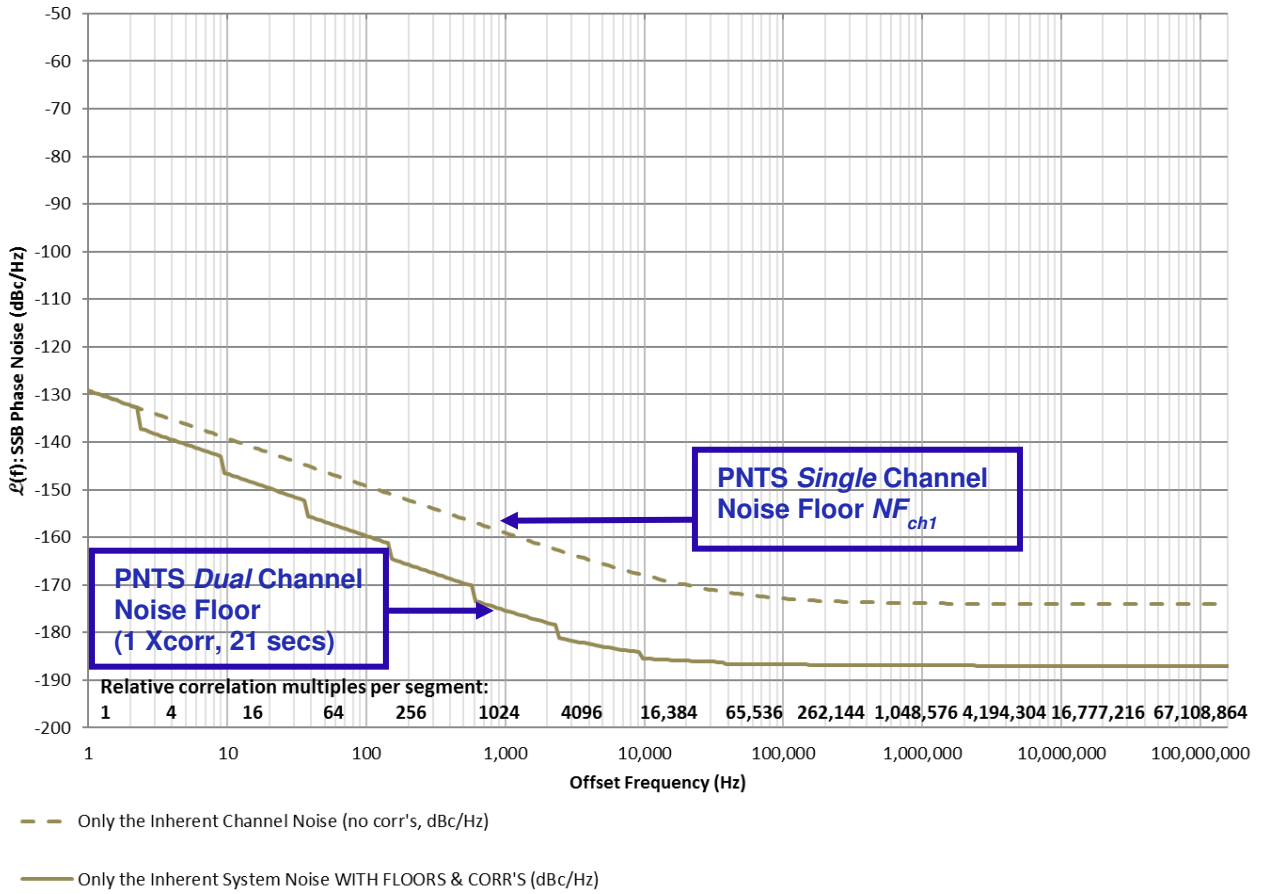

PNTS residual (system) noise floor (+10 dBm input signal, $kT = -187$ dBc/Hz) for both single (no cross-correlation) and dual channel (with cross-correlation) with 1 cross-correlation at 1 Hz offset in 21 seconds with a 128-point FFT size

Keysight N5511A Specification Summary

Phase detector input ports

Residual phase noise floor and spurious responses for *single-channel* (no cross-correlation)

(Does not include phase noise and spurious signals from a reference source)

Carrier frequency: 50 kHz to 1.6 GHz RF phase detector (All Options)		Carrier frequency: 1.2 GHz to 40 GHz Microwave phase detector (Option 540)	
Offset frequency	System noise floor	Offset frequency	System noise floor
0.01 Hz	-70 dBc/Hz	0.01 Hz	-55 dBc/Hz
1.0 Hz	-130 dBc/Hz	1.0 Hz	-115 dBc/Hz
10 kHz	-170 dBc/Hz	10 kHz	-160 dBc/Hz
10 kHz to 100 MHz	-170 dBc/Hz	10 kHz to 100 MHz	-160 dBc/Hz
>100 MHz	-164 dBc/Hz	>100 MHz	-155 dBc/Hz
Offset frequency	Spurious response	Offset frequency	Spurious response
0.01 Hz	-70 dBc	0.01 Hz	-50 dBc
0.1 Hz	-100 dBc	0.1 Hz	-80 dBc
> 10 Hz	-112 dBc	> 10 Hz	-97 dBc

Keysight N5511A AM Performance Summary

AM noise accuracy	
For frequencies from 250 MHz to 40 GHz when using "internal automatic self-calibration"	
±3 dB	0.01 Hz to 1 MHz offsets
±5 dB	1 to 40 MHz offsets
[-7, +4] dB	40 to 100 MHz offsets
[-10, +3] dB	100 to 160 MHz offsets
For frequencies from 50 kHz to 40 GHz when using single- or double-sided spur calibration	
±2 dB	0.01 Hz to 1 MHz offsets
±4 dB	1 to 40 MHz offsets
[-6, +3] dB	40 to 100 MHz offsets
[-9, +2] dB	100 to 160 MHz offsets

AM detector noise floor
(Tested at 1GHz and 4 GHz, input signal +10 to +20 dBm)

Offset from Carrier (Hz)	AM noise (dBc/Hz)									Spurious (dBc)		
	10	100	1k	10k	600k	1M	10M	100M	160M	10	1k	160M
Typical	-125	-130	-135	-143	-152	-160	-160	-158	-156	-72	-92	-92
Specifications	-105	-113	-121	-130	-150	-150	-150	-150	-145	-65	-85	-85

General Specifications

Operating temperature range: +0 °C to +55 °C

Warm-up time: 20 minutes

General considerations: The N5511A has low susceptibility to RFI and mechanical vibration. Care must be exercised however in making measurements in high RFI or vibration environments as spurious signals may be induced in the module.

Learn more at: www.keysight.com

For more information on Keysight Technologies' products, applications or services, please contact your local Keysight office. The complete list is available at: www.keysight.com/find/contactus

