

DATA SHEET

# InfiniiMax III/III+ Probing System

The world's highest performing probe system keeps getting better

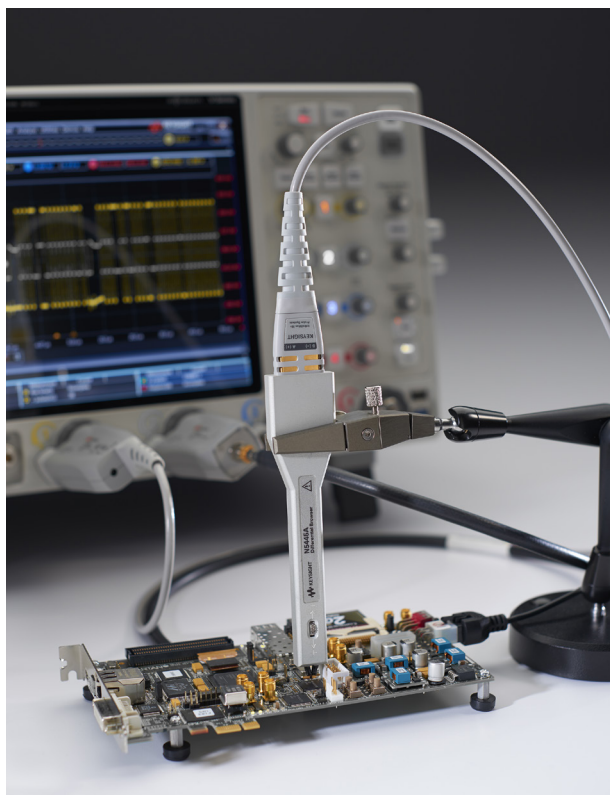

## Unmatched Performance

- Full 30 GHz bandwidth to the probe tip
- InfiniiMode probing for making differential, single-ended and common mode measurements with a single probe (with InfiniiMax III+)
- Industry's highest fidelity and accuracy due to bandwidth and extremely low loading
- Probe amplifiers loaded with measured s-parameters for more accurate response correction
- Bandwidth upgradable (InfiniiMax III only)
- Variety of probe heads for different use models with maximum usability



InfiniiMax III probe amplifier

## Industry-leading probe performance

The InfiniiMax III probing system offers you the highest performance available for measuring differential and single-ended signals, with flexible connectivity solutions for today's high-density ICs and circuit boards. Four different InfiniiMax III probe amplifiers ranging from 16 to 30 GHz are available for matching your probing solution to your performance and budget requirements. A proprietary 200 GHz fT InP (indium phosphide) IC process with backside ground vias and novel thick film technology is utilized to accommodate your highest performance needs and is unmatched by any product in the market.



InfiniiMax III+ probe amplifier (N2830A Series)

The N2830A/N7000A Series InfiniiMax III+ probing system is the next generation of InfiniiMax probing, greatly expanding the measurement capabilities and usability of a probe capable of measuring all components of a differential signal. The built-in InfiniiMode technology allows you to switch to differential, single-ended, and common mode without adjusting probe tip connections. The InfiniiMax III+ probe's InfiniiMode provides the following modes of operation.

- A - B (differential)
- A - ground (single-ended A)
- B - ground (single-ended B)
- (A+B)/2 - ground (common mode)

The InfiniiMax III+ works with the full array of InfiniiMax III probe heads and supports the full bandwidth of the InfiniiMax III+.



InfiniiMax III+ probe amplifier (N7000A Series)

## Highest fidelity and accuracy

The InfiniiMax III provides the highest bandwidth and incredibly low loading to allow for a new level of signal fidelity and accuracy. Continuing the probe head topology pioneered by Keysight Technologies, Inc. in the InfiniiMax I and II probe systems, five probe heads are provided to accommodate multiple use models: a 30 GHz browser that is extremely usable, a 25/28 GHz ZIF probe head with economical replaceable/removable ZIF tips, a 30 GHz 2.92 mm probe head which allows cabled measurements using 2.92 mm, 3.5 mm, or SMA coax cables, an economical 26 GHz solder-in probe head for demanding measurements, and a 16 GHz QuickTip for a quick and secure connection.

## More accurate probe correction

Each individual InfiniiMax III and III+ probe amp contains its unique S-parameters, and this frequency response data is used with the S-parameters of the various probe heads to further flatten the probe's magnitude and phase response for accuracy. Traditionally, probe correction uses a nominal model based on a typical probe amplifier instead of the specific amplifier. Generally, the biggest variation between probing systems is a result of the probe amplifier. The ability to correct a specific probe amplifier's response results in a more accurate probe correction, which yields a more accurate measurement.

## Uncompromised Usability

### Extensive line-up of probe heads and accessories

Keysight's InfiniiMax III/III+ probes support a wide variety of high-speed applications with an extensive line-up of probe heads and accessories.

The N5445A browser head (30 GHz) is the best choice for quick general-purpose troubleshooting of differential signals with its z-axis compliance and variable spacing from 20 mil to 125 mil (or 0.5 mm to 3.1 mm). The span between the signal tips is easily adjusted with a thumb wheel on the browser. Integrated LED lighting at the tip illuminates the probing area for better visibility. Order N5476A for replacement browser tips (set of 4).

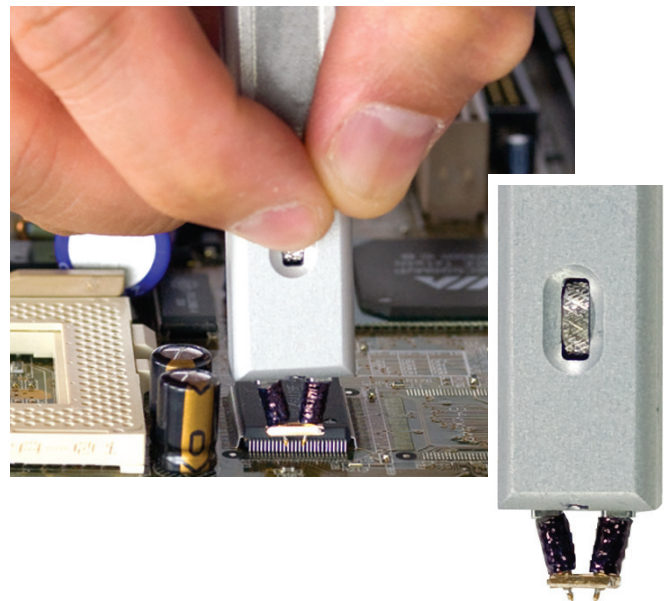
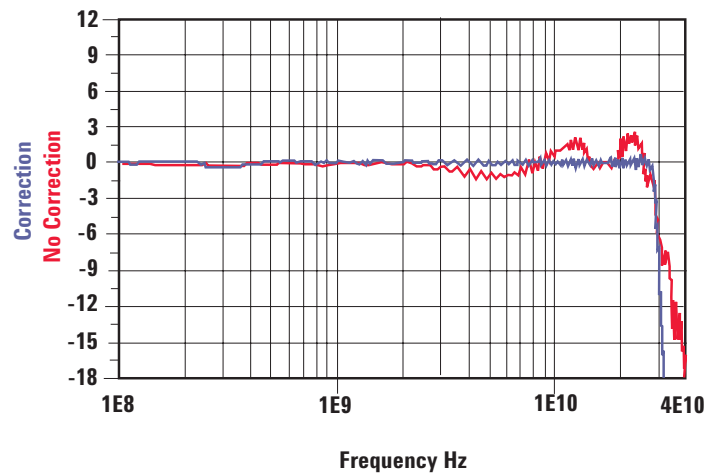
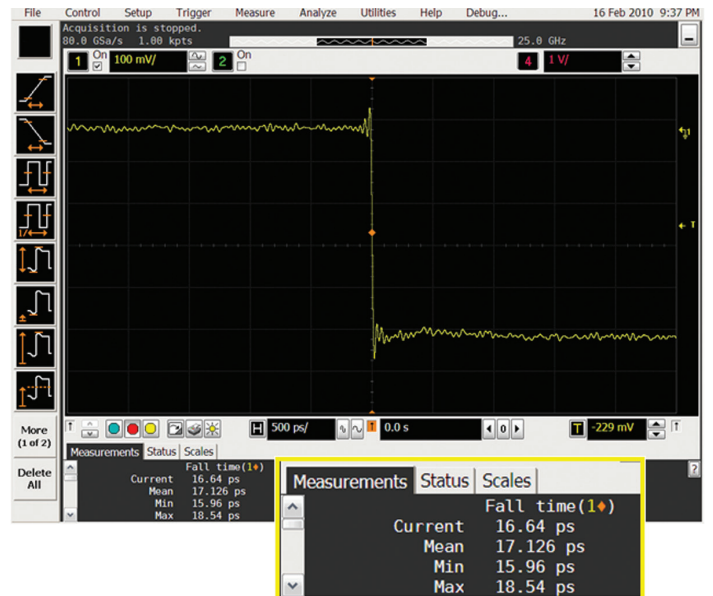

The N2848A/49A QuickTip offers the industry's first magnetically-engaged probe head and tip for a quick and secure connection, pushing the usability to the next level. The N2848A QuickTip probe head quickly snaps to the N2849A probe tip, utilizing magnets to connect to the two sides of the differential signal and ground. Multiple N2849A probe tips can be installed on a DUT, allowing quick and reliable measurement of many probe points. The QuickTip supports the InfiniiMode probing when used with the InfiniiMax III+ probe amp and supports differential probing with the InfiniiMax III probe amp. The N2849A QuickTip tips can also be used with the InfiniiMax I/II probe amps when used in conjunction with the N2851A QuickTip probe head for InfiniiMax I/II.

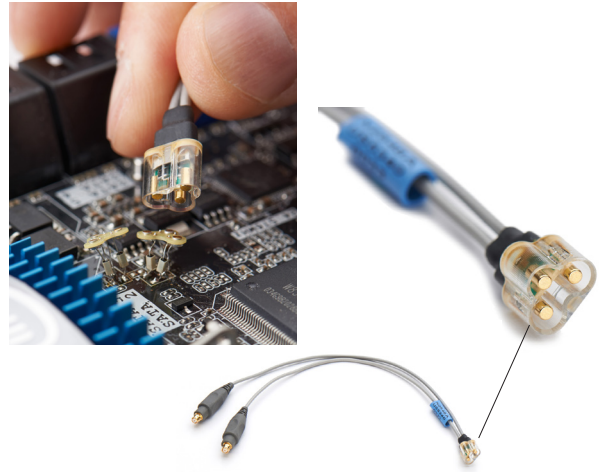

The N5439A ZIF probe head provides 28 GHz bandwidth in an economical replaceable tip form factor. For differential measurement, the N5439A ZIF probe head with the N5440A or N5447A ceramic ZIF tip provides the industry's lowest signal loading. The ZIF tips can be left on the DUT as the probe head is moved from one probing site to the next. Order N5440A (450 Ω ceramic), N5447A (200 Ω ceramic) or the new N2838A (450 Ω PC board) for a set of 5 ZIF tips with plastic sporks to aid in soldering the tips to your DUT. The N2838A PC board ZIF tip increased the robustness of the ZIF tip significantly while maintaining the bandwidth performance up to 25 GHz when used in conjunction with the N2803A and N5439A. Variable spacing from 5 mil to 80 mil (or 0.127 mm to 2 mm). (The N5447A 200 Ω ZIF tip is not compatible with InfiniiMax III+ probes.)

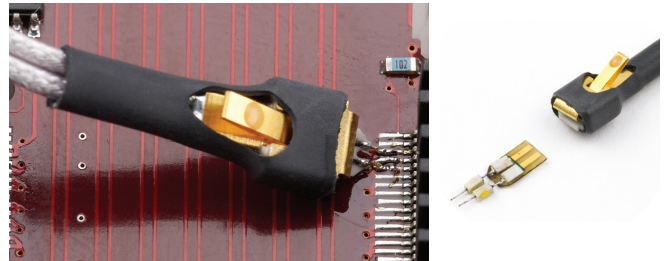

The N5444A 2.92 mm/3.5 mm/SMA probe head (30 GHz) allows you to connect two 2.92 mm, 3.5 mm or SMA cables to make a differential measurement on a single oscilloscope channel. Order N5444B 2.92 mm head flex cables (10" or 25 cm) or N2823A 2.92 mm cables with 1 m to extend the cable length and add convenience. You can control the termination voltage of the N5444A probe head using either the Infiniiium scope software or by using a N5444-61601 cable included in the N5444A kit connected to your own DC power supply.

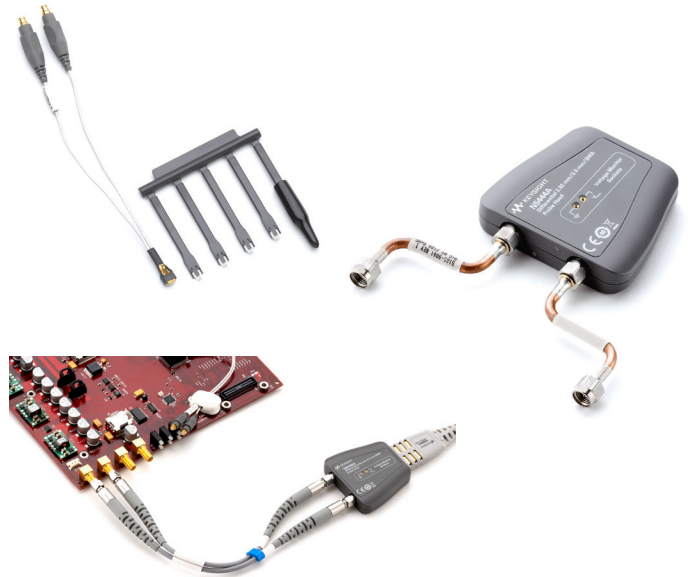

For extended temperature testing with extreme temperature range measurements, the MX0109A 26 GHz solder-in head supports extreme operating temperature of -55 to +150 °C per JEDEC JESD22-A104 revision E. Variable span of leads ranges from 5 to 250 mil. Damping resistor tips are user replaceable when damaged. This probe head is form, fit, function compatible with N2836A. This probe head supports InfiniiMode probing when used with the InfiniiMax III+ probe amp.





The N2836A solder-in head provides up to 26 GHz bandwidth when used in conjunction with the N2803A probe amplifier. This probe head supports InfiniiMode probing when used with the InfiniiMax III+ probe amp.

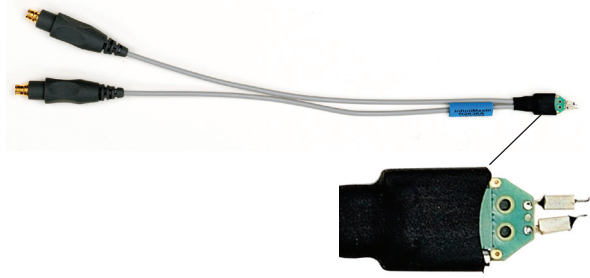

The N5442A Precision BNC 50  $\Omega$  adapter allows you to use your existing InfiniiMax I (1130B-1134B), InfiniiMax II (1168B/69B), N2750A-52A, N2795A-97A active probes or a general purpose 50  $\Omega$  BNC cable with the V, 90000 X- or 90000 Q-Series oscilloscope.



The N5449A high impedance adapter allows connection for probes that require a high impedance scope input such as a high impedance passive probe, 1147B/N2893A current probe, or N2790A differential probe to the InfiniiMax V, 90000-X/Q Series oscilloscopes. The N5449A provides switchable AC/DC coupling as well as 10:1 and 1:1 attenuation settings. The adapter comes with a N2873A 500 MHz 10:1 passive probe.



The N5477A sampling oscilloscope adapter makes the InfiniiMax III probing system fully compatible with the InfiniiMax 86100C DCA-J sampling oscilloscope. Previously the DCA-J was limited to 13 GHz of probing, but with the N5477A, the DCA-J now has 30 GHz of probing, increasing its performance and flexibility. To use the InfiniiMax III+ probe on sampling oscilloscopes, order the N1022B probe adapter and the 1143A probe offset control and power module.

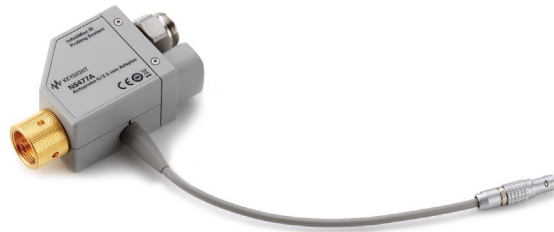

The MX0104A performance verification and deskew fixture is required to calibrate and verify the performance of the InfiniiMax III probe. The MX0104A is a replacement of the N5443A. The MX0104A comes with the 50 ohm through fixture only. You have an option to choose the option 001 plastic stand or the option N2787A 3D probe positioner which will help you properly position the probe amplifier. Order E2655C to calibrate and verify the performance of the InfiniiMax probe with < 13 GHz of bandwidth.



## Bandwidth upgradability (for InfiniiMax III)

As frequencies have continued to increase, so have the cost of probes. The InfiniiMax III system offers the world's first fully upgradable probe amplifier. Purchase a 16 GHz probe amplifier today, knowing that in the future, you can upgrade the amplifier to higher bandwidths (20/25/30 GHz) at a fraction of the cost of a new probe amplifier.

# InfiniiMax III/III+ Probing System Family Diagram

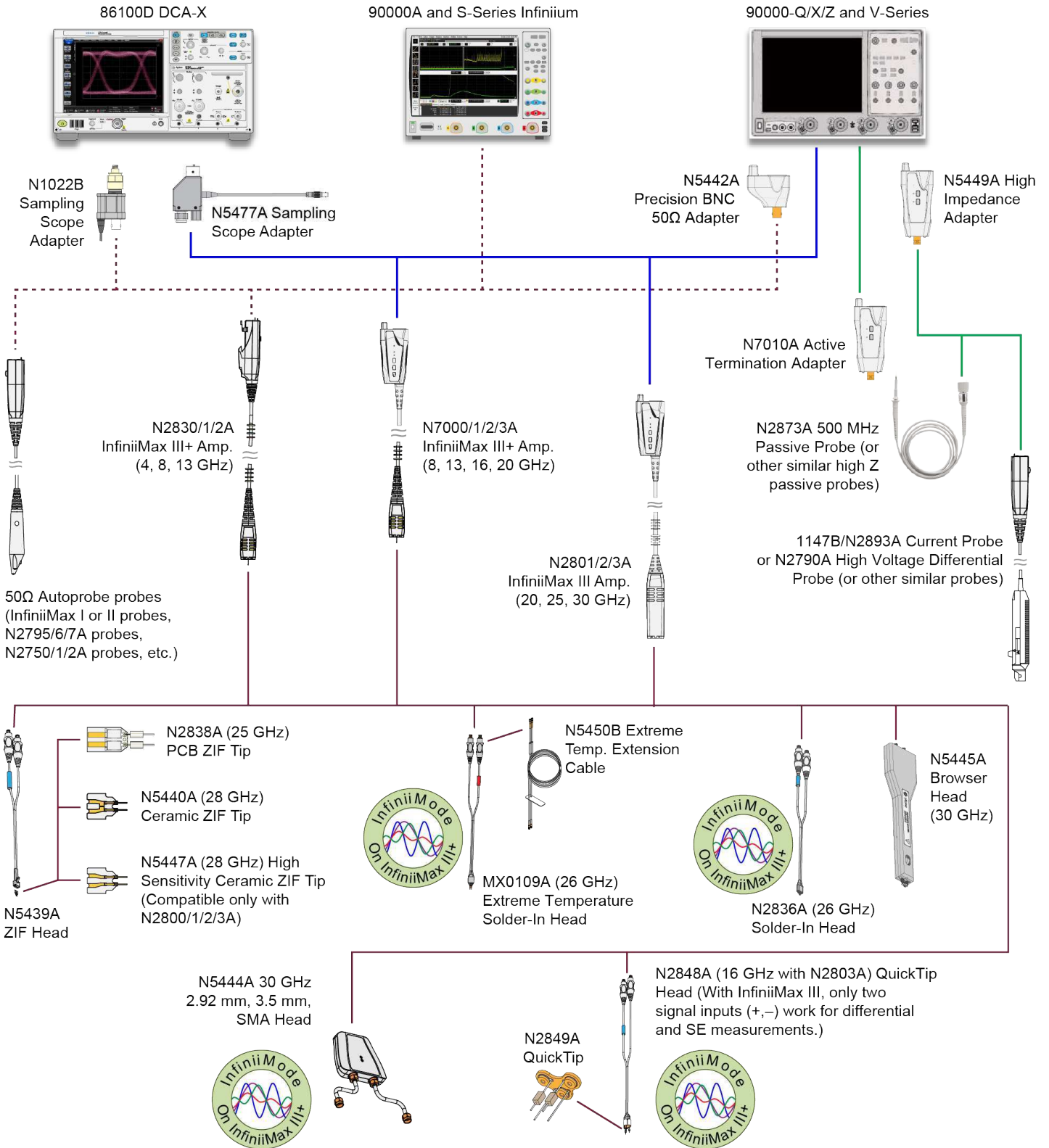

# Performance Specifications and Characteristics

## InfiniiMax III/III+ warranted specifications

Probe head	Probe amp	Bandwidth	DC input
N5440A_N5439A ceramic 450 Ω ZIF tip and ZIF probe head	N2803A 30 GHz probe amp	26 GHz	Rdiff=100 kΩ ± 2%, Rse=50 kΩ ± 2%
N5445A 450 Ω browser	N2803A 30 GHz probe amp	28 GHz	Rdiff=100 kΩ ± 2%, Rse=50 kΩ ± 2%
MX0109A/N2836A 450 Ω solder-in probe head vertical orientation with no ground wires	Differential mode N7003A 20 GHz probe amp	20 GHz	Rdiff=100 kΩ ± 2%, Rse=50 kΩ ± 2%

## InfiniiMax III/III+ probe head characteristics

These characteristics are mainly determined by the probe head. Performance numbers listed are: -3 dB bandwidth/10 to 90% transition time/20 to 80% transition time. Performance listed is with the highest bandwidth probe amp models in each family. Performance with lower bandwidth amps is the lower of the: AmpBW, (.434/AmpBW), (.308/AmpBW), or bandwidth measured with the highest bandwidth amp in the family.

Probe head	Input C	InfiniiMax III N2803A 30-GHz probe amp	InfiniiMax III+ N7003A 20-GHz probe amp		
		Differential mode	Differential mode	Single-ended mode	Common mode
N5440A_N5439A ceramic 450 Ω ZIF tip and ZIF probe head	Cdiff=32 fF; Cse=44 fF	28 GHz, 15.5 pS, 11.0 pS	20 GHz, 21.7 pS, 15.4 pS	N/A	
N5447A_N5439A ceramic 200 Ω ZIF tip and ZIF probe head	Cdiff=32 fF; Cse=44 fF	28 GHz, 15.5 pS, 11.0 pS	N/A		
N5445A 450 Ω browser	Cdiff=35 fF; Cse=50 fF	30 GHz, 14.5 pS, 10.3 pS	20 GHz, 21.7 pS, 15.4 pS	N/A	
N2838A_N5439A PC board 450 Ω ZIF tip and ZIF probe head	Cdiff=95 fF; Cse=130 fF	25 GHz, 17.4 pS, 12.3 pS	20 GHz, 21.7 pS, 15.4 pS	N/A	
MX0109A/N2836A 450 Ω solder-in probe head vertical orientation with no ground wires	Cdiff=108 fF; Cse=140 fF	27 GHz, 16.1 pS, 11.4 pS	20 GHz, 21.7 pS, 15.4 pS	N/A	
MX0109A/N2836A 450 Ω solder-in probe head flat orientation with minimum length ground wires	Cdiff=108 fF; Cse=140 fF	27 GHz, 16.1 pS, 11.4 pS	20 GHz, 21.7 pS, 15.4 pS		
N2849A_N2848A 450 Ω QuickTip and QuickTip probe head with ground wires connected	Cdiff=340 fF; Cse=200 fF	16 GHz, 27.1 pS, 19.3 pS	20 GHz, 21.7 pS, 15.4 pS		
N5444A 2.92 mm, SMA, 3.5 mm probe head	N/A	30 GHz, 15.5 pS, 11.0 pS	20 GHz, 21.7 pS, 15.4 pS		

## Performance Specifications and Characteristics (Continued)

### InfiniiMax III/III+ probe amp characteristics

These characteristics are mainly determined by the probe amp.

Features	N280XA InfiniiMax III probe amp			N283XA InfiniiMax III+ probe amp	
	450 $\Omega$ probe heads	200 $\Omega$ probe heads	N5444A 2.92 mm, SMA, 3.5 mm probe head	450 $\Omega$ probe heads	N5444A 2.92 mm, SMA, 3.5 mm probe head
DC input resistance	Rse=50 k $\Omega$ $\pm$ 2% each input to ground, Rdiff=100 k $\Omega$ $\pm$ 2% and Rcm=25 k $\Omega$ $\pm$ 2%	Rse=50 k $\Omega$ $\pm$ 2% each input to ground, Rdiff=100 k $\Omega$ $\pm$ 2% and Rcm=25 k $\Omega$ $\pm$ 2%	55 $\Omega$ to Vterm	Rse=50 k $\Omega$ $\pm$ 2% each input to ground, Rdiff=100 k $\Omega$ $\pm$ 2% and Rcm=25 k $\Omega$ $\pm$ 2%	55 $\Omega$ to Vterm
Input resistance > 10 kHz	Rse=500 $\Omega$ each input to ground, Rdiff=1 k $\Omega$ and Rcm=250 $\Omega$	Rse=500 $\Omega$ each input to ground, Rdiff=1 k $\Omega$ and Rcm=250 $\Omega$	50 $\Omega$ to .901*Vterm	Rse=500 $\Omega$ each input to ground, Rdiff=1 k $\Omega$ and Rcm=250 $\Omega$	50 $\Omega$ to .901*Vterm
Input voltage range (differential or single-ended), mains isolated	1.6 Vpp, $\pm$ 0.8 V (HD2&3 < -34 dbc), 2.5 Vpp, $\pm$ 1.25 V (HD2&3 < -38 dbc)	0.8 Vpp, $\pm$ 0.4 V (HD2&3 < -34 dbc), 1.6 Vpp, $\pm$ 0.8 V (HD2&3 < -38 dbc)	1.6 Vpp, $\pm$ 0.8 V (HD2&3 < -34 dbc), 2.5 Vpp, $\pm$ 1.25 V (HD2&3 < -38 dbc)	2.5 Vpp or $\pm$ 1.25 V at 5:1 attenuation, 5.0 Vpp or $\pm$ 2.50 V at 10:1 attenuation	2.5 Vpp or $\pm$ 1.25 V at 5:1 attenuation, 5.0 Vpp or $\pm$ 2.50 V at 10:1 attenuation without violating max input power
Max input power	N/A	N/A	125 mW calculated by $\{[r_{rms}(v_{in-vterm})]^2/55\}$ for each input	N/A	125 mW calculated by $\{[r_{rms}(v_{in-vterm})]^2/55\}$ for each input
Input common mode range	$\pm$ 2 VDC to 250 Hz, $\pm$ 1.25 V > 250 Hz	$\pm$ 6 VDC to 250 Hz, $\pm$ 0.65 V > 250 Hz	$\pm$ 6 VDC to 250 Hz, $\pm$ 1.25 V > 250 Hz without violating max input power	$\pm$ 7 VDC to 100 Hz, $\pm$ 1.25 V > 100 Hz at 5:1 attenuation, $\pm$ 2.5 V > 100 Hz at 10:1 attenuation	$\pm$ 6 VDC to 100 Hz, $\pm$ 1.25 V > 100 Hz at 5:1 attenuation, $\pm$ 2.5 V > 100 Hz at 10:1 attenuation without violating max input power
DC attenuation ratio	6:1	3:1	6:1	5:1 or 10:1 Automatically selected based on volts/division (all modes)	5:1 or 10:1 Automatically selected based on volts/division (all modes)
Offset range (for probing a single-ended signal)	$\pm$ 16 V	$\pm$ 8 V	$\pm$ 6 V without violating max input power	$\pm$ 16 V	$\pm$ 6 V without violating max input power
Input referred noise spectral density	23.9 nV/rt (Hz)	12.0 nV/rt (Hz)	23.9 nV/rt (Hz)	Diff 5:1 atten 33.5 nV/rt (Hz) Diff 10:1 atten 53.9 nV/rt (Hz) SE A or B 5:1 atten 27.8 nV/rt (Hz) SE A or B 10:1 atten 47.7 nV/rt (Hz) CM 5:1 atten 21.8 nV/rt (Hz) CM 10:1 atten 38.4 nV/rt (Hz)	
Input referred noise example	4 mVrms with 28 GHz probe head and 30 GHz probe amp	2 mVrms with 28 GHz probe head and 30 GHz probe amp	4 mVrms	4.5 mVrms in diff mode 5:1 atten with $\geq$ 18 GHz probe head and 13 GHz probe amp	4.5 mVrms in diff mode 5:1 atten with 30 GHz N5444A probe head and 13 GHz probe amp
Maximum input voltage	18 Vpeak mains isolated	18 Vpeak mains isolated	8 Vpeak without violating max input power	18 Vpeak mains isolated	8 Vpeak without violating max input power



## What is InfiniiMode?

InfiniiMode allows convenient measurement of differential, single-ended and common mode signals with a single probe tip - without reconnecting the probe from its connection point.

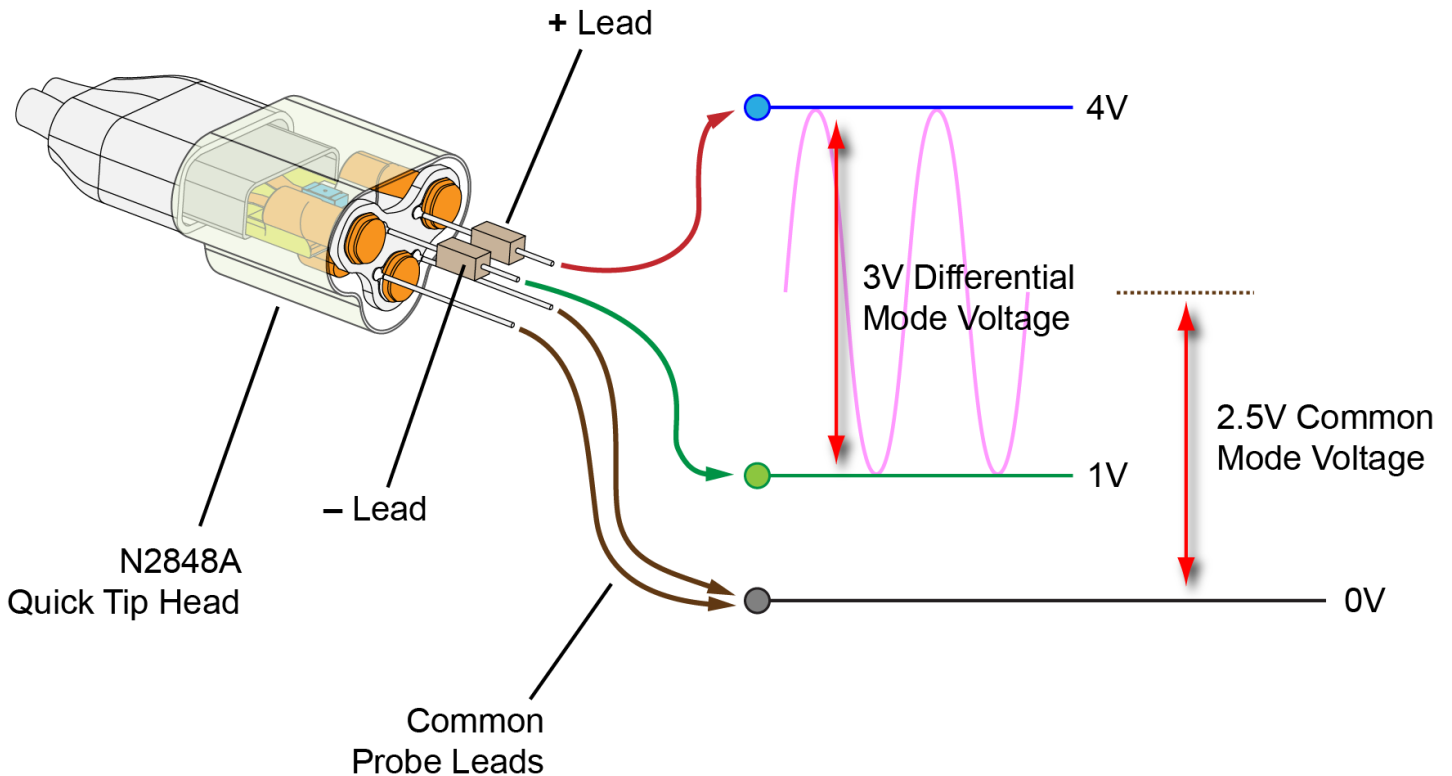

## Ordering Information

### InfiniiMax III/III+ probe amplifier models

Model number	Description	Recommended oscilloscope
N2803A	30 GHz InfiniiMax III probe amplifier	Infiniium 90000X/Q/Z Series 28 to 63 GHz models
N2802A	25 GHz InfiniiMax III probe amplifier	Infiniium 90000X/Q/Z Series 25 GHz models
N7003A	20 GHz InfiniiMax III+ probe amplifier	Infiniium 90000X/V/Q/Z Series 20 GHz models
N2801A	20 GHz InfiniiMax III probe amplifier	Infiniium 90000X/Q/Z Series 20 GHz models
N7002A	16 GHz InfiniiMax III+ probe amplifier	Infiniium 90000V/X Series 16 GHz models
N2800A	16 GHz InfiniiMax III probe amplifier	Infiniium 90000X Series 16 GHz models, discontinued and replaced by N7002A
N7001A	13 GHz InfiniiMax III+ probe amplifier	Infiniium 90000V/X Series 13 GHz models
N2832A	13 GHz InfiniiMax III+ probe amplifier	Infiniium 90000X 13 GHz and 90000A models
N7000A	8 GHz InfiniiMax III+ probe amplifier	Infiniium 90000V Series 8 GHz models
N2831A	8 GHz InfiniiMax III+ probe amplifier	Infiniium 90000A and S-Series
N2830A	4 GHz InfiniiMax III+ probe amplifier	Infiniium 90000A and S-Series

Note: InfiniiMax III and III+ probe amps are not compatible with existing InfiniiMax I or II probe heads.

## Ordering Information (Continued)

### InfiniiMax III/III+ probe heads

Model number	Description	Notes
N2848A	InfiniiMax III QuickTip probe head	Compatible with InfiniiMax III/III+ amp Supports InfiniiMode with InfiniiMax III+ amp
N2849A	InfiniiMax III QuickTip tips	Set of 4 tips
N5445A	InfiniiMax III browser head	Order N5476A for replacement probe tips (set of 4)
N5439A	InfiniiMax III ZIF probe head	Order N2838A PC board ZIF (450 Ω), N5440A Ceramic ZIF (450 Ω) or N5447A Ceramic ZIF (200 Ω) for a set of 5 ZIF tips with plastic sporks
N5444A	InfiniiMax III 2.92 mm/3.5 mm/SMA probe head	Order N5448B (25 cm) or N2823A (1 m) 2.92 mm (m)-to-2.92 mm (m) head flex cables to extend the cable length. Supports InfiniiMode with InfiniiMax III+ amp
N5441A	InfiniiMax III 16 GHz solder-in probe head	Discontinued and replaced by N2836A and MX0109A
N2836A	InfiniiMax III 26 GHz solder-in probe head	Supports InfiniiMode with InfiniiMax III+ amp. Order N2836-68701 for damping resistor replacement tips
N2835A	InfiniiMax III differential connectivity kit	Contains 1x N5445A, 2x N2836A, 2x N5439A, 2x N2838A, 2x N2848A, 2x N2849A
MX0109A	InfiniiMax III 26 GHz Extreme temperature solder-in probe head	Supports -55 to +150 °C of operating temperature range and InfiniiMode with InfiniiMax III+ amp. Order N2836-68701 for damping resistor replacement tips

Note: InfiniiMax III/III+ probe heads are not compatible with InfiniiMax I or II probe amps.

### InfiniiMax III probe adapters

Model number	Description	Notes
N5442A	Precision BNC adapter (50 Ω)	For use with InfiniiMax I/II/III+ probes, N2750A-52A, N2795A/96A/97A, 1156A-58A etc.
N5449A	High impedance probe adapter	Includes one N2873A 500 MHz 10:1 passive probe
N5477A	Sampling scope adapter	For InfiniiMax III amp to use with Keysight 86100C DCA-J sampling scope
N1022B	Probe adapter	For InfiniiMax III+ amp to use with 86100C DCA-J sampling scope
MX0104A	Performance verification and deskew fixture	For InfiniiMax III and InfiniiMax III+ > 13 GHz. Order option 001 plastic stand or the option N2787A 3D probe positioner.
E2655C	Performance verification and deskew fixture	For InfiniiMax III+ ≤13 GHz and InfiniiMax I/II
N2852A	AutoProbe II to AutoProbe III interface adapter for Infiniium UXR Series	

### Probe bandwidth upgrade options (for InfiniiMax III only)

Model number	Description	Notes
N5446A-001	16 to 20 GHz bandwidth upgrade	
N5446A-002	20 to 25 GHz bandwidth upgrade	
N5446A-003	25 to 30 GHz bandwidth upgrade	
N5446A-004	16 to 25 GHz bandwidth upgrade	
N5446A-005	16 to 30 GHz bandwidth upgrade	
N5446A-006	20 to 30 GHz bandwidth upgrade	

Note: Purchase two or more upgrade options to go from 16 to 25 or 30 GHz and 20 to 30 GHz. To upgrade the probe bandwidth, you simply need to send the probe to the Keysight service center.

### Other recommended accessories for InfiniiMax III/III+ probing system

Model number	Description	Notes
N2787A	3D probe positioner	For hands-free probing
N5450B	Extreme temperature extension cable	1 m long, check out Keysight literature 5990-3504EN for other available probe accessories for extreme temperature testing
N2812B	High performance input cable, 2.92 mm connectors, 1 m length	For use with Infiniium V, 90000-X/Q Series oscilloscope
N5448B	Phase matched cable pair, 25 cm, 2.92 mm (m) to 2.92 mm (m)	> 40 GHz bandwidth. Skew error matched to < 5 psec
N2823A	Phase matched cable pair, 1 m, 2.92 mm (m) to 2.92 mm (m)	> 40 GHz bandwidth. Skew error matched to < 5 psec
MV-23	Carson Optical MagniVisor	<a href="http://www.carsonoptical.com/Magnifiers">www.carsonoptical.com/Magnifiers</a>



[www.keysight.com/find/infinimax3](http://www.keysight.com/find/infinimax3)

Learn more at: [www.keysight.com](http://www.keysight.com)

For more information on Keysight Technologies' products, applications or services, please contact your local Keysight office. The complete list is available at: [www.keysight.com/find/contactus](http://www.keysight.com/find/contactus)



Find us at [www.keysight.com](http://www.keysight.com)

This information is subject to change without notice. © Keysight Technologies, 2015 - 2019, Published in USA, April 29, 2019, 5990-5653EN