

STANDARD POWER

PS²L Series Programmable Test Equipment

02-PSL-80

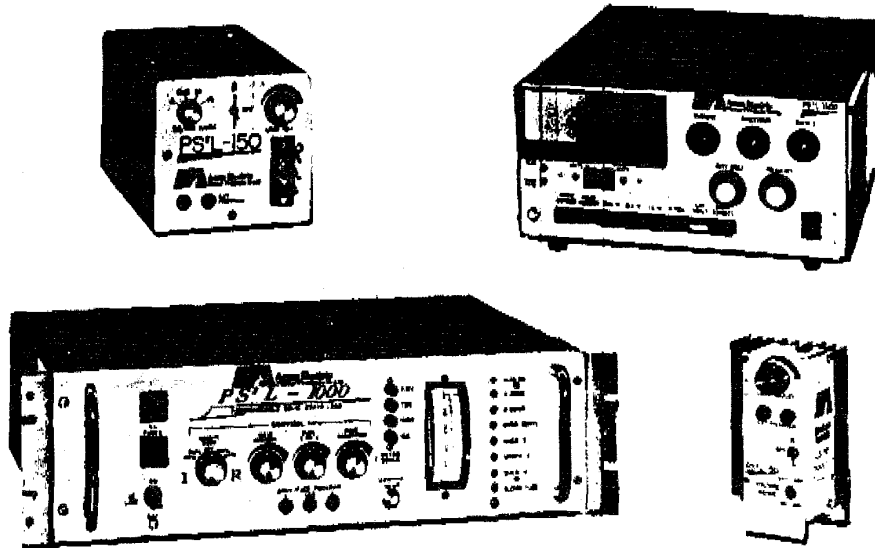

Electronic Loads for Flexibility, Accuracy and Protection

Acme Electric Corporation, a leader in the manufacture of custom and standard power supplies, designed and built in-house programmable test equipment to assure high-quality standards for production. This line of programmable test equipment has been used successfully in our research and development laboratories, receiving inspection, production testing, and quality assurance functions.

Our power conversion customers, noting the versatility and flexibility of this test equipment, suitable in so many applications, were instrumental in convincing us to offer this product line. Thanks to these perceptive customers, you, too can employ the PS²L Series to solve your power testing requirements. Four models offer a choice of capacities up to 50, 150, 1000 or 1500 continuous watts of DC output and up to 1800 watts pulsed output.

The PS²L Series is a highly reliable, simple to use, bench-top design. The PS²L 1000 model is also rack mountable.

General Specifications	Portable		Indicating	
	PS ² L 50	PS ² L 150	PS ² L 1000	PS ² L 1500
Maximum Loading Power @ 25°C	50W	150W	1000W	1500W (1800W Pulse)
Maximum Load Current	10 Adc	30 Adc	10 Adc	30 Adc
Maximum Load Voltage	60 Vdc	60 Vdc	60 Vdc	30 Vdc
External Programming Input	15KΩ	15KΩ	1V/10 Amp Load	10V/30 Amp Load
Square Wave Response	150 μsec 5A Step	300 μsec/ 10A Step	1 μsec/Amp >150 μsec	0.0 μsec/ Amp
Operating Power Requirements	Self-Powered		115-230 Vac, 47/63 Hz	
Circuit Protection	Load Fusing		Overload and Overvoltage	
Cooling	Convection		Forced-Air	

Besides the standard features common to the PS²L Series, individual units offer added flexibility and versatility to suit your applications.

And of course, the PS²L Series is available from Acme Electric's nationwide network of electronic distributors.

Standard Features

- Constant resistance/constant current regulation better than 1%
- All units programmable
- Front-panel controls
- High reliability

- Circuit protection per general specifications.
- Full range of units for most applications

One Year Warranty

Acme Electric warrants that its programmable loads will be free from defects in material and workmanship. Acme Electric will repair or replace these products if found to be defective, within one year from date of manufacture. See 02-SPI-05 for a complete copy of the limited warranty summarized here.



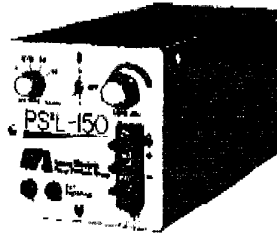

Portable Loads

PS²L 50, PS²L 150 Characteristics

The PS²L 50 and PS²L 150 are light-weight, portable, single level DC power loads. Range selectable, both units are internally biased by the power supply under test and require no AC operating power. Load current can be controlled on the unit or programmed externally.

Convection cooling permits full operation up to 25°C. Derating data is available for forced-air applications up to 55°C.

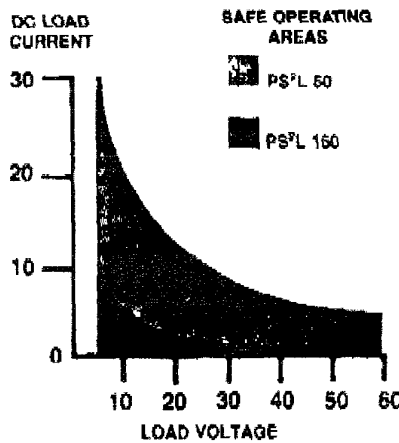

Portable Loads	PS ² L 50	PS ² L 150
Maximum Loading Power (Watts)	50	150
Maximum Load Current (A dc)	10	30
Maximum Load Voltage (V dc)	60	
Minimum Load Voltage (V dc)	4.0	4.5
Constant Current Range (5V)	1mA-10A	10mA-30A
Constant Resistance Range (5V)	0.5Ω -5KΩ	0.167Ω -500Ω
External Programming Capability	Static/Dynamic	
Programming Input Resistance	15KΩ	
Square Wave Response	150 μsec/5A	300 μsec/10A
Reverse Polarity Protection	1-12A Fuse	3-12A, 1-1/2A Fuse

Front Panel:	PS ² L 50	PS ² L 150
Load Current	Pos:Neg screw terminals	
External Program	Jack terminals	
Mode Selection Switch	R-OFF-I	R-OFF-I
Load Adjust Pot	10 turn, precision, wire wound	
Voltage Range Switch	4-30, 30-60	5, 12, 24, 48
Operating Ambient	0°C-25°C Convection Cooled Derating data available for operation to 55°C	

Physical Data:	PS ² L 50	PS ² L 150
Dimensions (W, H, D (in.))	3.44 x 5.63 x 3.25	11.0 x 5.38 x 5.0
Weight	1.5 lbs.	3.0 lbs.

Indicating Loads

PS²L 1000 Characteristics

The PS²L 1000 provides DC loading capabilities, both static and dynamic, for an infinite number of voltage-current combinations, both as constant current and constant resistance. In addition, the two levels of either current or resistance remain at their settings without continual readjustment.

For dynamic loading, these solid-state loads accept a programmed input for external connection of a signal generator. Dynamic current changes can be monitored directly on the PS²L without use of an external shunt.

The meter functions both as a dual scale voltmeter and a current meter for direct readings. An LED display indicates which of two operational modes is controlling the load current and any protective shutdown mode which occur.

The unit is forced-air cooled, and is designed for a standard 19 inch rack mounting or bench top use.

PS²L 1500 Characteristics

The highly versatile PS²L 1500 can test virtually any power supply in either constant current or constant resistance modes. When testing batteries and capacitor banks, the discharge current is user-selectable. In addition, circuit breaker testing can also be accomplished in the constant-current mode.

The PS²L 1500 can be used to test DC voltage regulators in static mode up to 1500 watts. A built-in pulse control allows a user to vary repetition rate and duty factor. Up to 1800 watts total pulse input is permitted at a 50% duty cycle. Precision adjustments are made through ten-turn potentiometers.

The PS²L 1500 provides static testing in either constant current or constant resistance modes and dynamic testing using a constant current pulsed load.

Additional standard features include: full four-digit display for voltage and current, true short circuit testing from the front panel, and scope outputs for sampling.

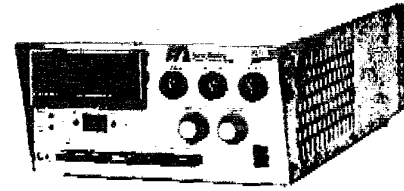
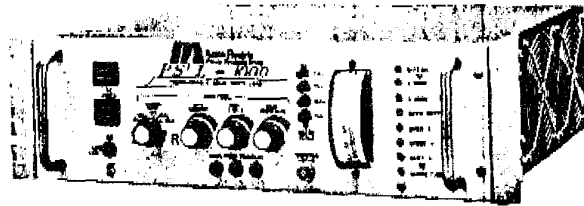

Indicating Loads	PS²L 1000	PS²L 1500
Maximum Loading Power @ 55°C (Watts)	1000	1500 (1800 pulse)
Maximum Load Current (A dc)	110	300
Maximum Load Voltage (V dc)	60	30
Minimum Load Voltage (V dc)	1.0 - 0.018 I	1.5
Overvoltage Shutdown (V dc)	70-74	32-40
Remote Programming Input	1 Volt/10 Amp Load	1 Volt/30 Amp Load
Current Signal Output	-50mV/Amp Load	10mV/Amp Load
Square Wave Response	1 μsec/Amp > 150 μsec	0.8 μsec/Amp
Protective Circuitry	Reverse Polarity Overvoltage Undervoltage Overpower AC Power Fusing	Reverse Polarity Overvoltage Thermal Trip
AC Power Requirements	115/230 Vac, 47-63 Hz, 2A/1A	
Operating Ambient	0°C-55°C Fan Cooling	

PS²L 1000

Front Panel

- Dual scale volt/amp meter, ± 2% accuracy, meter range switches: 7.5 and 75 Vdc, 15 and 150 Adc
- LED display: Operational mode and status of the protective circuits
- Current monitor output — BNC, connection
- Program terminals — jack input
- Current level control potentiometers (3 ea.)
- 5-position mode/level switch control
- AC power, ON/OFF switch and fuse holders (2)

Rear Panel

- AC line cord, load bus terminals

PS²L 1500

Front Panel

- Digital volt/amp meter ± 1% accuracy, meter function switch 0-30.00 volts, 0-300.0 amps
- LED Indicators showing metering mode and status of the protective circuit
- Current monitor output — BNC connection
- Enable Switches: Static dynamic load current, Pulsed current mode, Constant current mode, External Input, Short circuit and static resistance ranging (1-10-100A/V)
- Level controls: Constant current, Constant resistance, Pulsed current, Pulsed duty cycle and Pulse frequency
- AC power on/off

Rear Panel

- AC line cord and fuse holder, load bus terminals and external programming terminal strip

Physical Data	PS²L 1000	PS²L 1500
Dimensions (W, H, D (in.))	19.0 x 5.25 x 16.0	10.0 x 5.75 x 21.0
Weight	52 lbs	25 lbs

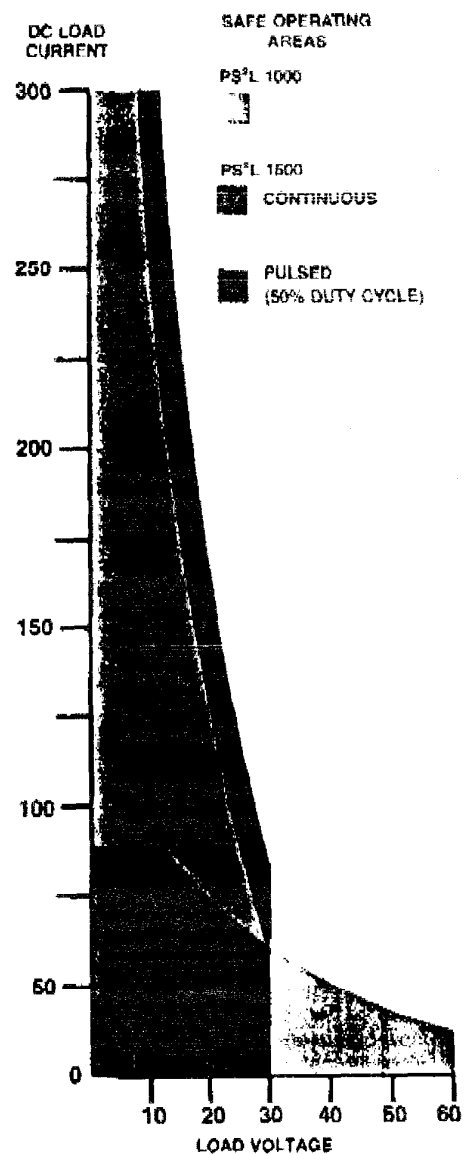

MOUNTING SPECIFICATIONS

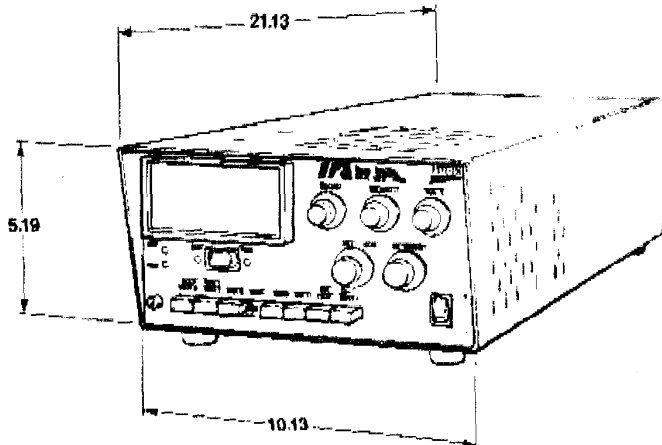
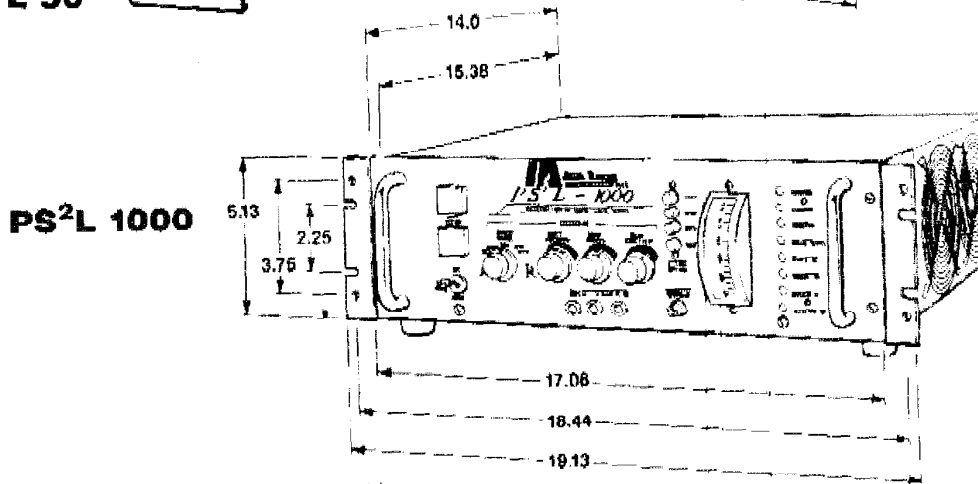
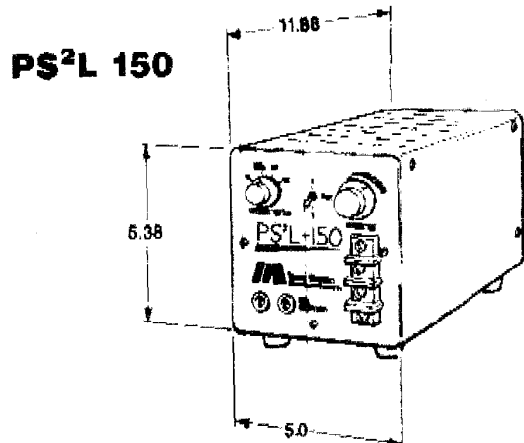
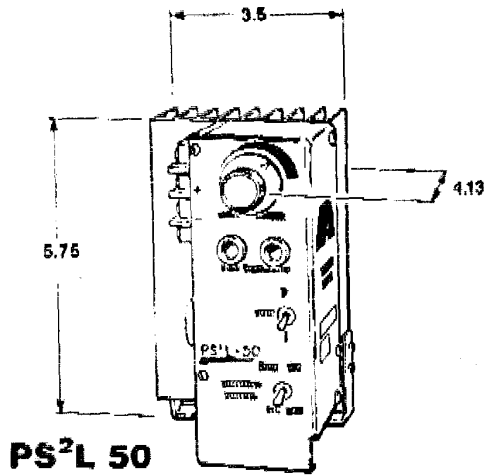

NOTE:
 Rubber mounting feet
 add 0.63 to height
 shown.
 All dimensions in inches.



Eastern Sales: Route 4, Box 54, Lumberton, NC 28358
 Toll Free: 1-800-247-7507, Within NC: (919) 738-8202
 Telex: 558291, FAX: (919) 739-0024
Western Sales: 6416 Amelia Earhart Drive, Salt Lake City, UT 84116
 Toll Free: 1-800-843-2263, Within UT: (801) 539-0227
 Telex: 389467, FAX: (801) 539-0237

Eastern Sales: 20 Water Street, Cuba, NY 14727
 Telephone: (716) 968-2400, Telex: 532403, FAX: (716) 968-5048
Western Sales: 6416 Amelia Earhart Drive, Salt Lake City, UT 84116
 Telephone: (801) 539-0227, Telex: 389467, FAX: (801) 539-0237